



STEINBAUER PERFORMANCE

INNOVATION. EXPERTISE. INTEGRITY.

STEINBAUER Performance is a leading developer and manufacturer of Intelligent Microprocessor PowerModules. As the first company to bring the Injection Duration Module to the market, we have continued to push the boundaries and innovate new and safer ways to increase the power and torque of today's diesel and turbo-gas engines.

STEINBAUER PowerModule

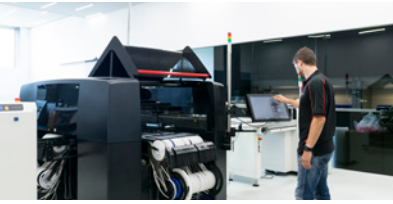

TUNE SAFE!

ENGINE TUNING METHODS EXPLAINED



STEINBAUER POWER MODULE

- **PATENTED** - U.S. PATENT NO. 7 765 987 **
- **SAFETY** - MANUFACTURER'S SAFETY SETTINGS REMAIN IN PLACE
- **EASE OF INSTALLATION** WITH ORIGINAL VEHICLE-SPECIFIC CONNECTORS
- **NO CHANGE** IN FUEL PRESSURE
- **NO INTERFERENCE** WITH THE ECU / ECM
- **FIELD TESTED** WORLDWIDE
- **ORIGINAL EQUIPMENT MANUFACTURER** QUALITY
- **3 YEAR EXTENDED WARRANTY** ON YOUR STEINBAUER POWER MODULE ***

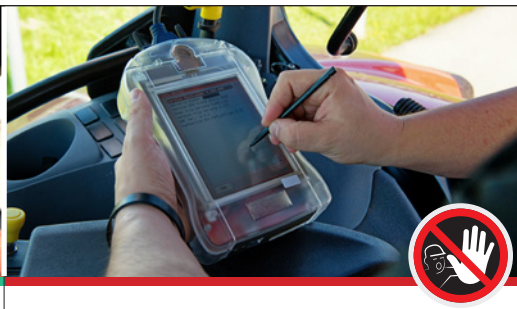

ECU FLASHING RE-PROGRAMMING

- **INCREASE OF BOOST AND FUEL PRESSURE**
- **ERROR CODES ARE DEACTIVATED!** LIMITS OF SENSOR VALUES **INCREASED**
- **BACKUPS ARE RARELY MADE** OF THE FACTORY ECU FIRMWARE
- **INCREASED STRESS** ON THE ENGINE
- SAFETY PARAMETERS ARE IGNORED - **DANGER OF AN ENGINE FAILURE**
- CUSTOM **SOFTWARE OFTEN DELETED** DURING SCHEDULED MAINTENANCE
- **NO ACTUAL PHYSICAL PRODUCT** - CANNOT BE USED ELSEWHERE



RAIL PRESSURE CHEAP ELECTRONICS

- **INCREASE OF BOOST AND FUEL PRESSURE**
- **CHEAP PARTS FROM UNKNOWN ORIGIN** - RARELY IN A WEATHERPROOF CASING
- **SIMPLE INSTALLATION VIA WIRING LOOM**
- **SIMPLE SOFTWARE** INTEGRATED
- THE INCREASE OF FUEL PRESSURE AND COMBUSTION TEMPERATURE RESULTS IN **HIGHER LOAD** ON THE FUEL SYSTEM
- WORST CASE SCENARIO: **ENGINE FAILURE**
- **INCREASED STRESS** ON ENGINE PARTS
- HIGH RISK OF **FOOTPRINT ON THE ECU**

UP TO **20%**
MORE POWER /
MORE TORQUE*



POWER ENHANCEMENT FOR TURBO-DIESEL ENGINES

- » SAFE PERFORMANCE FOR YOUR ENGINE
 No change in fuel pressure
- » UNIQUE POWER ENHANCEMENT PRINCIPLE
 Power increase achieved by optimizing the main injection length
- » NO FOOTPRINT LEFT ON THE ECU
 When uninstalled, engine reverts to factory standard
- » DEVELOPED & MANUFACTURED IN AUSTRIA
 At our headquarters in Wartberg ob der Aist

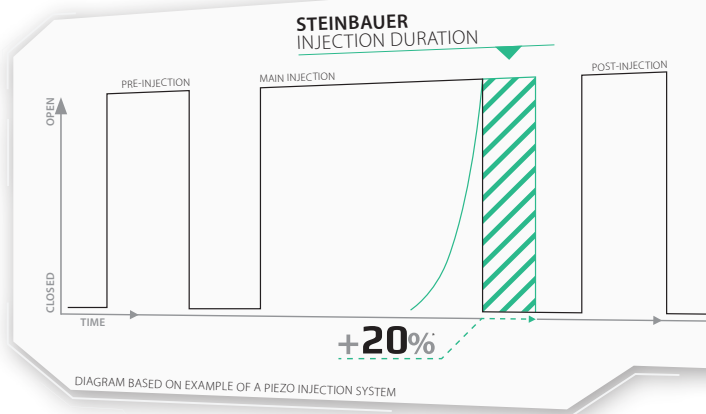

WHY STEINBAUER? BENEFITS FOR HEAVY TRUCKS

- » POWER RESERVE FOR HEAVY LOADS
 Without negative effects on engine life
- » REDUCED GEAR SHIFTING
 Improved efficiency and less driver fatigue
- » DRIVE WITHIN THE OPTIMAL RPM RANGE
 On inclines and passing other vehicles
- » SAVE TIME & MONEY
 Reduce end-to-end delivery times

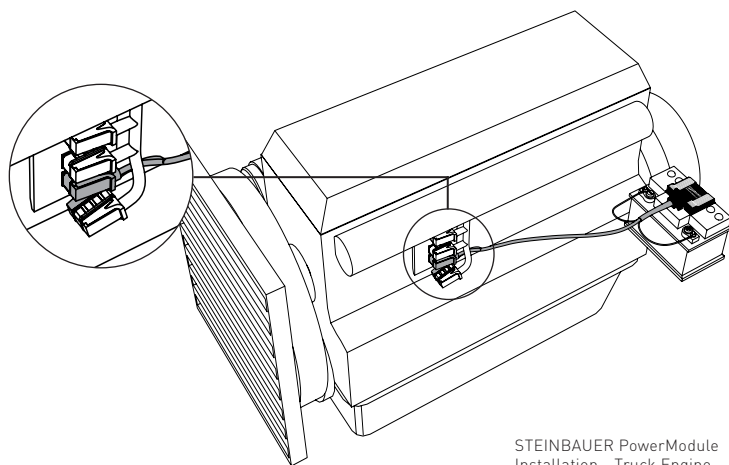

CONTACT US

STEINBAUER Performance Austria
 Betriebsstrasse 21, 4224 Wartberg / Aist
 T: +43 (7236) 21-8-210 | E: info.at@steinbauer.cc

Your dealer:

* Results dependent on, but not limited to: individual driver habits and experience; vehicle handling; type of engine and standard manufacturers engine variables; total load weight and distribution; weather, road and terrain conditions.