



Raptor

SOIL PROCESSOR

Skid Steer Version Manual

Version 2.0



Owners/Operators/Service Manual

Office Phone: 715-393-4458 5311 Fuller St. Weston,
WI 54476 Email: Info@nortecequip.com

It is the responsibility of the owner and/or operator to read this manual and to train all other operators before they start working with the machine. Follow all safety instructions exactly. Safety is everyone's business. By following recommended procedures, a safe working environment is provided for the operator, bystanders and the area around the worksite. Untrained operators are not qualified to operate this machine.

Date of Purchase:

Serial Number:

Model Number:

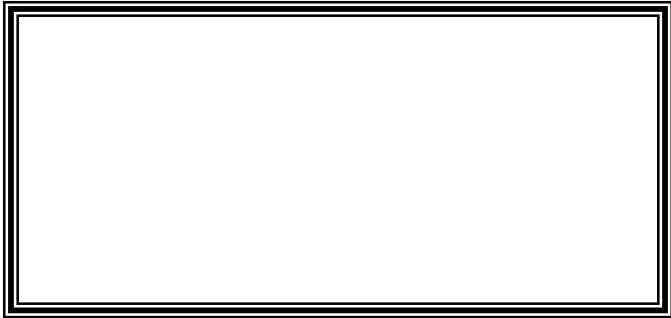

IMPORTANT: Fill out warranty card and mail within 10 days of purchase date. Your warranty depends on information being filed at the factory.

Your Servicing Dealer Is

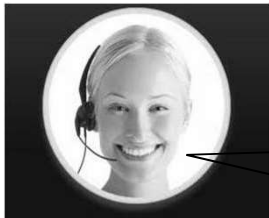

**If You Need Additional Assistance
For Set-Up or Operating After Reading Owners Manual,
Please Call Product Support **715-393-4458****

Owners Manual Serial Number: _____

Print Date: _____

Safety / Owner's Manual

Thank you for purchasing a NORTEC EQUIPMENT LLC Product. We appreciate having you as a customer and wish you many years of safe and satisfied use of your machine.

As a Nortec Equipment LLC customer and if you feel the need for further training or have questions about safety, operation or maintenance call Nortec Equipment LLC Product Support 715-393-4458 ask for product specialist.

In conjunction with reading and understanding the Raptor owners / operator manual also read and understand your prime mover (tractor / skid steer) owners / operator manual.

Read all safety decals in this manual and on the Raptor.

Know and obey all OSHA regulations, local laws and other guidelines.

If safety decals become damaged replace immediately.

If your Raptor Soil Processor is not meeting your expectations, in most cases it's a matter of a simple adjustment or understanding method of operation. Contact your dealer or Nortec Equipment.

Make sure your prime mover (tractor - skid steer) is compatible with the Raptor. Also proper prime mover counter weights as required.

Operate the Raptor as low to the ground as possible when in transport mode.

Ground speed between 2 to 6 mph. In severe duty applications reduce ground speed.



WARNING:

BOLT TORQUE CHART

After every ten (10) hours of operation, check all hardware and tighten where required.

SAE Series Torque Chart

DO NOT use these values if a different torque value or tightening procedure is listed for a specific application. Torque values listed are for general use only.

Fasteners should be replaced with the same grade.

Make sure fastener threads are clean and you properly start thread engagement. This will prevent them from failing when tightening.

SAE Bolt Head Identification



SAE Grade 2 (No Dashes)



SAE Grade 5 (3 Radial Dashes)

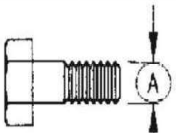

SAE Grade 8 (6 Radial Dashes)

Bolt Diameter "A"	Wrench Size	MARKING ON HEAD					
		SAE 2		SAE 5		SAE 8	
		Lbs.-Ft	(N-m)	Lbs.-Ft	(N-m)	Lbs.-Ft	(N-m)
1/4	7/16	6	(8)	11	(15)	14	(19)
5/16	1/2	13	(18)	21	(28)	25	(34)
3/8	9/16	23	(31)	38	(52)	55	(75)
7/16	5/8	37	(50)	55	(75)	80	(110)
1/2	3/4	57	(77)	85	(115)	120	(165)
9/16	13/16	82	(111)	125	(170)	180	(245)
5/8	15/16	111	(150)	175	(240)	230	(310)
3/4	1 1/8	200	(270)	300	(410)	440	(600)
7/8	15/16	280	(380)	450	(610)	720	(975)
1"	1 1/2	350	(475)	680	(925)	1035	(1400)
1 1/8	1 11/16	450	(610)	885	(1200)		
1 1/4	1 7/8	600	(815)	1255	(1700)		
1 3/8	2 1/16	675	(915)	1620	(2200)		
1 1/2	2 1/4	920	(1250)	2200	(2900)		



CAUTION:



A nylon nut, also referred to as a nylon-insert lock nut, polymer-insert lock nut, or elastic stop nut, is a kind of locknut. It is a nut with a nylon collar insert that resists turning. Nylon insert is not damaged by installation and therefore they can be reused many times. Replacement of self-locking nuts is critical in areas that may be needed.

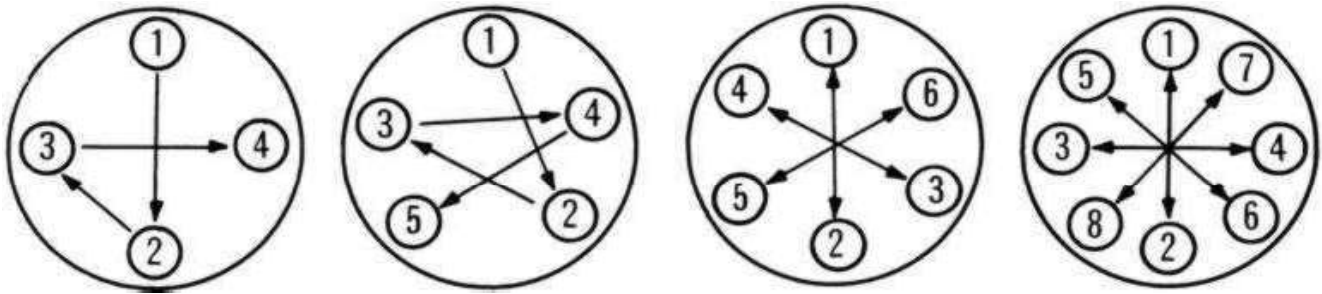

During all of the following steps, keep any gap between flanges even all around the circumference, and nuts made up approximately the same amount on each end of the bolt.

First time around just snug the nuts with a hand wrench.

Second time around tighten the nuts firmly with the same wrench.

Third time around apply approximately 25% recommended torque.

Fourth time apply approximately 75% of recommended torque.

Fifth time around, apply 100% of recommended torque.

Continue tightening nuts all around until nuts do not move under 100% recommended torque.

If possible, re-torque after 24 hours. Most of any bolt preload loss occurs within 24 hours.



DANGER Being a powered attachment there is a possibility of flying objects.

NORTEC has an excellent reputation for quality and workmanship. Contact the Dealer for replacement parts.

- (1) Read and understand owner's manual, not only NORTEC EQUIPMENT LLC but also power unit.**
- (2) Follow all safety instructions.**
- (3) Use common sense when operating equipment, both power unit and implement.**

This manual is an important part of your machine and should remain with the machine at all times. Reading your operator's manual will help you and others avoid personal injury or damage to the machine. Information given in this manual will provide the operator with the safest and most effective use of the machine. Knowing how to operate this machine safely and correctly will allow you to train others who may operate this machine.

Special Message The machine shown in this manual may differ slightly from your machine. Instructions are complete for all models to help you understand safe operation.

NORTEC EQUIPMENT LLC Serial Number Plate Your dealer will need the model and serial number of your equipment to supply you with the correct parts.

NORTEC EQUIPMENT LLC Owners Manual package with each and every unit. Customer is responsible to insure the tractor-skid steer being used is capable of handling, operating, lifting and transporting equipment prior to equipment purchase.



BEFORE OPERATION

Carefully study and understand this manual.

Do not wear loose-fitting clothing which may catch in moving parts.

Always wear protective clothing and safety shoes/footwear.

Keep wheel lug nuts or bolts tightened to specified torque.

Assure that agricultural implement tires are inflated evenly.

Give the unit a visual inspection for any loose bolts, worn parts or cracked welds, and make necessary repairs. Follow the maintenance safety instructions included in this manual.

Be sure that there are no tools lying on or in the equipment.

Do not use the unit until you are sure that the area is clear, especially children and animals.

Don't hurry the learning process or take the unit for granted. Ease into it and become familiar with your equipment. Practice operation of your equipment and its attachments. Completely familiarize yourself and



DANGER:

**If Owner's Manual is missing,
Replace Immediately!**

Replacement Owner's Manual Part Number: NE-000362



other operators with its operation before using.

Use a tractor equipped with a Roll Over Protective System (ROPS) and fasten your seat belt prior to starting the engine.

The manufacturer does not recommend usage of tractor with ROPS removed.

Move tractor wheels to the widest recommended settings to increase stability.

Securely attach to towing unit. Use a high strength, appropriately-sized hitch pin with a mechanical retainer and attach safety chain.

Do not allow anyone to stand between the tongue or hitch and the towing vehicle when backing up to the equipment.



DURING OPERATION

Children should not be allowed on the product.

Clear the area of small children and bystanders before moving the feeder.

Securely attach feeder to towing unit, using a hardened 3/4" pin, a metal retainer, and safety chains if required. Shift towing unit to a lower gear before going down steep downgrades, thus using the engine as a retarding force. Keep towing vehicle in gear at all times. Slow down for corners and rough terrain.

Make sure you are in compliance with all local and state regulations regarding transporting equipment on public roads and highways. Lights and slow moving signs must be clean and visible by overtaking or oncoming traffic when feeder is transported.

SAFETY CHAIN - If equipment is going to be transported on a public highway, a safety chain should be obtained and installed. Always follow state and local regulations regarding a safety chain and auxiliary lighting when towing farm equipment on a public highway. Be sure to check with local law enforcement agencies for your own particular regulations. Only a safety chain (not an elastic or nylon/plastic tow strap) should be used to retain the connection between the towing and towed machines in the event of separation of the primary attaching system.

Install the safety chain by crossing the chains under the tongue and secure to the draw bar cage or hitch or bumper frame.

Beware of bystanders, particularly children! Always look around to make sure that it is safe to start the engine of the towing vehicle or move the unit. This is particularly important with higher noise levels and quiet cabs, as you may not hear people shouting.

NO PASSENGERS ALLOWED - Do not carry passengers anywhere on, or in, the tractor or equipment, except as required for operation.

Keep hands and clothing clear of moving parts.

Do not clean, lubricate or adjust your equipment while it is moving.

When halting operation, even periodically, set the tractor or towing vehicle brakes, disengage the PTO, shut off the engine and remove the ignition key.

Be especially observant of the operating area and terrain - watch for holes, rocks or other hidden hazards. Always inspect the area prior to operation.

DO NOT operate near the edge of drop-offs or banks.

DO NOT operate on steep slopes as overturn may result.

Operate up and down (not across) intermediate slopes. Avoid sudden starts and stops.

Unauthorized Modifications to the Machine May Impair Function and Safety



Read and understand this manual and all safety signs before operating and maintaining. Review the safety instructions and precautions annually.

TAKE NOTE! THIS SAFETY ALERT SYMBOL FOUND THROUGHOUT THIS MANUAL IS USED TO CALL YOUR ATTENTION TO INSTRUCTIONS INVOLVING YOUR PERSONAL SAFETY AND THE SAFETY OF OTHERS. FAILURE TO FOLLOW THESE INSTRUCTIONS CAN RESULT IN INJURY OR DEATH.



THIS SYMBOL MEANS **ATTENTION!

****BECOME ALERT!**

****YOUR SAFETY IS INVOLVED!**

SAFETY SIGNAL WORDS



Note the use of the signal words DANGER, WARNING and CAUTION with the safety messages. The appropriate signal word for each has been selected using the following guidelines:



Indicates an imminently hazardous situation that, if not avoided, will result in death or serious injury. This signal word is to be limited to the most extreme situations typically for Nortec machine components which, for functional purposes, cannot be guarded.

CAUTION:



Indicates a potentially hazardous situation that, if not avoided, could result in death or serious injury, and includes hazards that are exposed when guards are removed. It may also be used to alert against unsafe practices.

WARNING:



Indicates a potentially hazardous situation that, if not avoided, may result in minor injury or death. moderate injury. It may also be used to alert against unsafe practices.

DANGER:



WARNING Check and Read tractor, skid steer or loader operator's manual for proper operating instructions!



WARNING Important! Be careful when operating the machine. Lifting can be dangerous. Proper machine compatibility is important. Check with power unit owner's manual for proper specifications and ballasting.



HIGHWAY AND TRANSPORT OPERATIONS

Adopt safe driving practices:

Keep the brake pedals latched together at all times. NEVER USE INDEPENDENT BRAKING WITH MACHINE IN TOW AS LOSS OF CONTROL AND/OR UPSET OF UNIT CAN RESULT.

Always drive at a safe speed relative to local conditions and ensure that your speed is low enough for an emergency stop to be safe and secure. Keep speed to a minimum.

Reduce speed prior to turns to avoid the risk of overturning.

Avoid sudden uphill turns on steep slopes.

Always keep the tractor or towing vehicle in gear to provide engine braking when going downhill. Do not coast.

Do not drink and drive!

Comply with state and local laws governing highway safety and movement of farm machinery on public roads.

Use approved accessory lighting flags and necessary warning devices to protect operators of other vehicles on the highway during daylight and nighttime transport. Various safety lights and devices are available from your dealer.

The use of flashing amber lights is acceptable in most localities. However, some localities prohibit their use. Local laws should be checked for all highway lighting and marking requirements.

When driving the tractor and equipment on the road or highway under 40 kph (20 mph) at night or during the day, use flashing amber warning lights and a slow moving vehicle (SMV) identification emblem.

Plan your route to avoid heavy traffic.

Be a safe and courteous driver. Always yield to oncoming traffic in all situations, including narrow bridges, intersections, etc.

Be observant of bridge loading ratings. Do not cross bridges rated lower than the gross weight as which you are operating.

Watch for obstructions overhead and to the side while transporting.

Always operate equipment in a position to provide maximum visibility at all times. Make allowances for increased length and weight of the equipment when making turns, stopping the unit, etc.

ASSISTANCE

If you have questions not answered in this manual, or require additional copies, or the manual is damaged, please contact your dealer or: NORTEC EQUIPMENT LLC

Safety Check List



Proper operator training!

All new operators need training, read operators manual, walk around equipment review.

Proper machine maintenance!

Check for loose bolts, stress areas breakage/welds/damage/twisting of components.

Proper hydraulic maintenance!

Check for loose hydraulic fittings, oil leaks, cut hoses.

10 Hour Break-In Period

After running the machine for 10 hours, check for loosening of bolts. Factory installed Loc-Tite is used in assembly to prevent bolts from loosening up. During break-in period, hardware could seat into paint causing loosening of bolts. Relocking and tightening



DANGER

If operating in heavy rock or debris, reduce the speed.

Both engine and travel speed.

When angling the power rake, there could be side pull (rotor walking the direction the power is directed and rotation of rotor)

bolts prevents bolts from loosening up again. DO NOT overtighten bolts - overtightening bolts can cause stretching of the hardware, causing stripping of hardware. All machines are factory greased - after break-in period, machine needs to be regreased.

Getting Started

ASSISTANCE

If you have questions not answered in this manual, or require additional copies, or if the manual is damaged, please contact your dealer or: NORTEC EQUIPMENT LLC

Tractor Version

Make sure the NORTEC driveline is the proper length. If the driveline is too long, it may bottom out and damage either the gearbox or the tractor. If it is too short, in a sloping application or if the machine comes off the ground, the drive shaft may come apart. Check all hydraulic hoses for leaks or cuts and either repair or replace. Before operating the machine, be sure you know and understand the controls on both the tractor/skid steer and the machine. Inspect the working area for hazards and make a note of them before you begin. Keep all bystanders at a safe distance while operating equipment.

Safety of the operator is one of the main concerns in designing and developing a new piece of equipment.

Designers and manufacturers build in as many safety features as possible. However, every year many accidents occur which could have been avoided by a few seconds of thought and a more careful approach to handling equipment. You, the operator, can avoid many accidents by observing the following precautions. To avoid personal injury, study the following precautions and insist those working with you, or for you, follow them.

Replace any CAUTION, WARNING, DANGER or instruction safety decal that is not readable or is missing. Location of such decals is indicated in this booklet.

Do not attempt to operate this equipment under the influence of drugs or alcohol.

Review the safety instructions with all users annually.

This equipment is dangerous to children and persons unfamiliar with its operation. The operator should be a responsible adult familiar with farm machinery and trained in this equipment's operations. Do not allow persons to operate or assemble this unit until they have read this manual and have developed a thorough understanding of the safety precautions and of how it works.

Proper operator training!

WARNING: All new operators need training, read operators manual, walk around unit training.



Proper machine maintenance!

Check for loose bolts, stress areas breakage/welds/damage/twisting.

Proper hydraulic maintenance!

Check for loose hydraulic fittings, oil leaks, cut hoses.



DANGER

WARNING-Avoid Injury or Death!!

NEVER leave machine running unattended.

NEVER leave equipment off the ground when out of operator's seat.

NEVER allow children or untrained personnel to operate the equipment.



DANGER
across

Be extra careful when working on inclines. When operating on a slope, always operate up and down the slope, never the slope.



WARNING

Keep machine low to the ground to prevent roll over. NEVER operate with machine up in the air.



DANGER

When angling the processor there could be side pull (rotor walking in the direction the power is directed and rotation of rotor).



DANGER

Tractor Version Proper length of PTO shaft, too short a PTO shaft will come off and cause personal harm or damage tractor/implement.



WARNING

Make sure lower draft arm linkage is snug (tightened) up so there is no side play (rocking back and forth) relationship of implement to tractor.



WARNING

Important! Be careful when operating the machine. Lifting can be dangerous. Proper machine compatibility is important.



WARNING

Check and read tractor, skid steer or loader operator's manual for proper operating instructions!

NORTEC TIP: Recommended using a grease gun with a flexible hose and pistol grip for better control.

Grease Requirement: Use any high-quality, multi-purpose #2 or lithium grease



Clean off grease fitting before greasing. NOT cleaning off grease fitting will insert/inject foreign material into system creating damage and undue wear. If grease seeps out of grease fitting and grease gun injector means grease fitting is damaged. Either remove grease fitting and clean out old dried up grease or replace grease fitting. Grease the machine when not using it for extended time or when putting it in storage for the season. Grease the machine when washing or storing it out side in the weather, this will blow out any water that may get into system and creating a seal for dirt to get into.

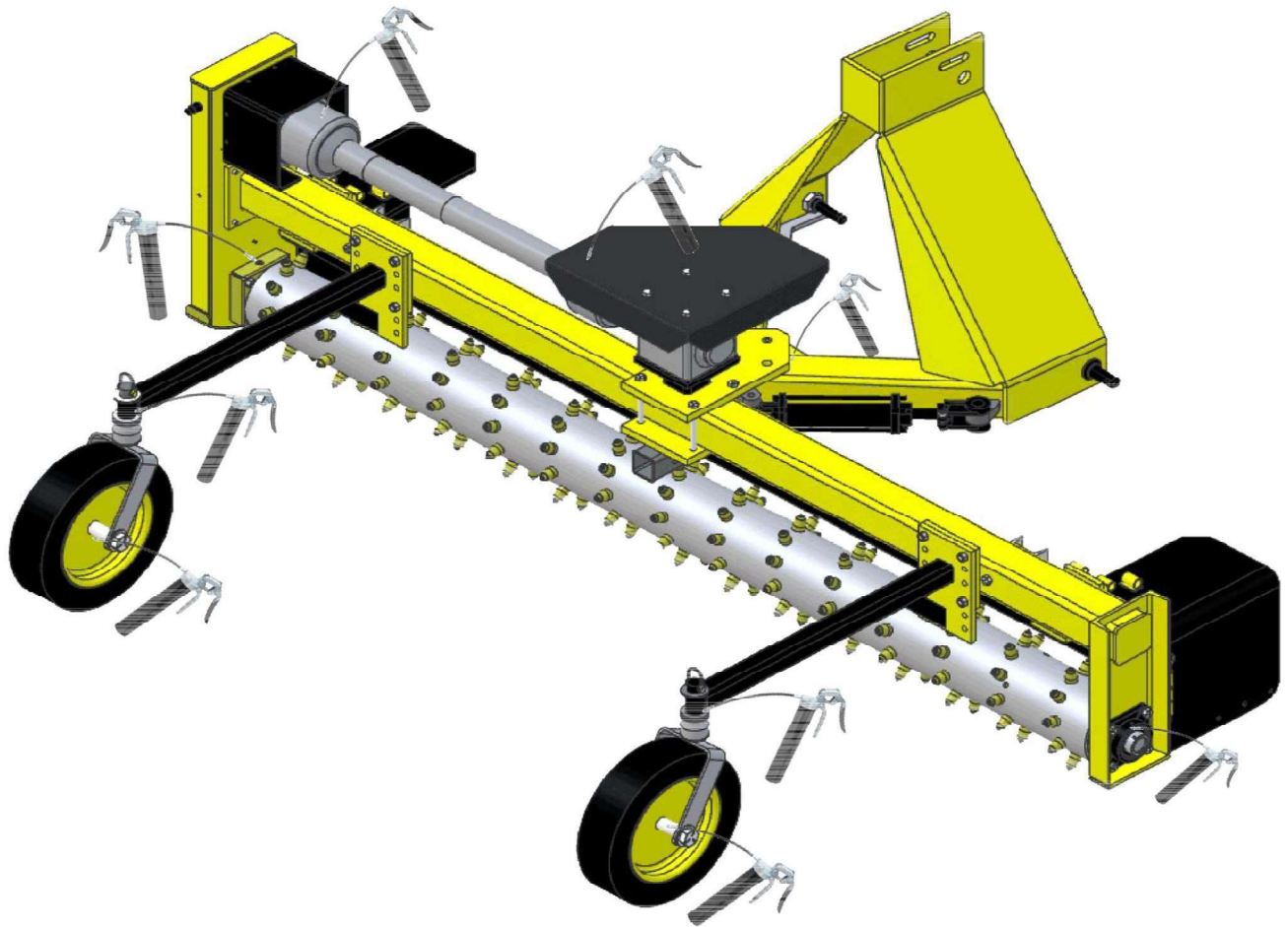

DO NOT OVER GREASE

A bearing housing full of grease can generate heat. One of the biggest differences between grease and oil is that grease cannot transfer heat out of the load zone. By putting too much grease in a bearing, you can create heat from fluid friction. Because the heat has nowhere to go, it can begin to degrade the grease by causing too much churning.

Nortec uses in most bearing applications a triple lip seal bearings. Over greasing will PUNCH OUT THE SEAL, allowing dirt and water to enter the bearing. NO more than 2 shots of grease every 75 hours under normal operation.



ATTENTION:Horsepower (H.P.)

The following is a guideline for approximat horsepower (HP) requirements at the Tractor PTO.

“Note this is a guideline not an absolute standard”

Implement H. P. requirements can vary as much as 50% in different soil conditions. Heavy damp soil consumes more H. P. than sandy dry soils and faster ground speeds require more

H. P. Slower ground speeds may be necessary in different conditions. In addition; tractor age can also reduce lifting capacity and available H. P. output.

Two wheel drive or four wheel drive is not a determining factor however; the four wheel drive adds front end weight that may reduce the need for an additional front weight kit.

Tractor Version

Standard	Horse Power Rating
Pro6T	25 to 50 hp
Pro7T	30 to 80 hp

Heavy Duty

Pro HD 6	50 to 80 hp
Pro HD 7	50 to 80 hp
Pro HD 8	50 to 80 hp

Super Duty

Pro-Super 6	All Models
Pro-Super 7	60 to 120 hp / 150hp**
Pro-Super 8	Larger HP Tractors
Pro-Super 10	May be used because of
Pro-Super 12	the Dual Clutch

3-Point Hitch Requirements



The lift capacity of the tractor should be considered first before horsepower; make sure to add weights of each Raptor Soil Processor with options for total implement weight. The tractor should be capable of not just lifting but **safely transporting** the machine in the lifted position over uneven terrain. A tractor may have the available horsepower to power the attachment however it may not CAUTION: have the capacity to lift and safely operate.

Note; the tractor lift capacity is measured approximately 24" (60 cm) behind the lifting arms and tractor H. P. required is at the PTO not the engine. Look at the tractor's specifications for lifting capacity and HP ratings for better accuracy. In addition, it may be necessary to add front weights to offset the attachment weight for safe operation.

What is the difference between Category 1 and 2 tractors?

The lower lift arms on a 3 point hitch cat 1 are 26" wide, with the top link being 18 inches above the center line, between the two lower lift arms. The lower lift pins are 7/8" in diameter, and the top link pin is 3/4". The cat 1 hitch is used on tractors from 20-45 hp. A cat 2 hitch is 32" wide. The top link is located 24" above the center line between the two lower lift pins. The lower lift pins are 1-1/8" inch in diameter. The top link pin is 1" in diameter. The larger Cat 2 hitch is designed for use with tractors ranging from 40-100 hp.



Quick Hitch

COMPATIBLE / COMPLIANCE

Special Note: Some attachment

manufacturers are not following or designing into them

attachment SAE standards.

Specifications on the implement /

attachment is not always correct. In this case it's impossible to use the Time

Saver Quick Hitch. Most quality main line attachment manufacturers engineer and design their implements to accept a Quick Hitch.

Common Question: Does a 3 point hitch float?

The 3 pt hitch is always in float because the weight of the implement provides the down-force. The round knob (between the seat) will adjust the drag factor on the 3 point hitch bars and they quickly drop.

Category	Typical Tractor Power	Top / Center Link (1)	Lift / Draft Arm (2)	Lower Hitch Spacing
0	Up to 20 hp	5/8in (16mm)	5/8in (16mm)	20 in (510 mm)
1	20-45 hp	3/4 in (19 mm)	7/8 in (22 mm)	28 in (710 mm)
2	40-100 HP	1 in (25 mm)	1-1/8 in (29 mm)	34 in (860 mm)
3	80-225 HP	1-1/4 in (32 mm)	1-7/16 in (37 mm)	40 in (1,000 mm)
4	More than 180 HP	1- 3/4 in (44 mm)	2 in (51 mm)	48 in (1,200 mm)

You may notice some sub-compact tractors, such as the John Deere 1 Series or Kubota BX Series have a "limited" category 1 hitch. This indicates that the hitch is lower to the ground and may not lift as high or open as wide as standard full-size category 1 hitches. Industry refers to this hitch as limited. Nortec refers to this as NON COMPLIANCE. Reason being it is not compliant with Cat 1 specifications.



WARNING

Important! Be careful when operating the machine. Lifting can be dangerous. Proper machine compatibility is important.

Check with power unit owner's manual for proper specifications and ballasting.

3-Point Hitch Tractor Version

Standard

Quick Hitch: Compliance Cat 1

Pro6T

Cat 1

Pro7T

Cat 1



Heavy Duty Quick Hitch: Compliance Cat 2 / Cat 1 Non Compliance

Pro HD 6

Cat 2 Combo 1-2

Pro HD 7

Cat 2 Combo 1-2

Pro HD 8

Cat 2 Combo 1-2



Super Duty

Quick Hitch: Compliance Cat 2 Non Compliance Cat 3 Heavy Duty

Pro-Super 6

Cat 2-3

Pro-Super 7

Cat 2-3

Pro-Super 8

Cat 2-3

Pro-Super 10

Cat 2-3

Pro-Super 12

Cat 2-3

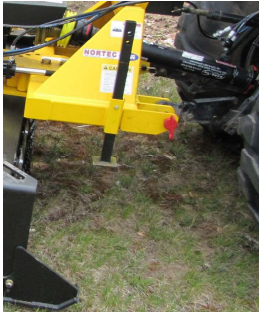

A jack stand is provided to keep the machine off the ground for easy hook up and removal. Simply remove pin and slide jack stand up for machine installation or down for machine removal. Note: Operating the jack stand in the down position can damage the jack stand.



Important! Be careful when operating the machine. Lifting can be dangerous.

WARNING Proper machine compatibility is important. Check with power unit owner's manual for proper specifications and ballasting.

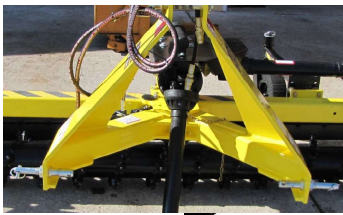
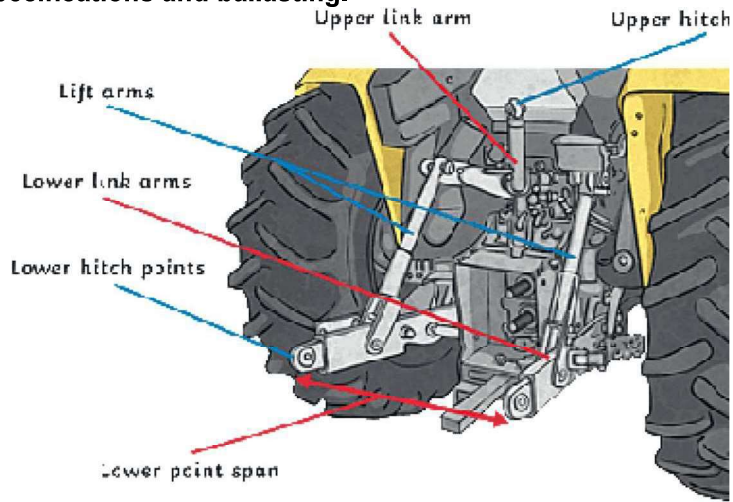

Raptor Standard and Raptor Heavy Duty Only

Draft arm hitch pin may be inserted outwards or inwards depending on 3-point hitch.

Cat 1 standard or cat 1 non-traditional. Proper location aids in easy hook up.

Either the rigid or the float position on the center link can be used for operation. When using the float position, the unit will be in constant travel in relationship to the tractor/ground.

Combo Pin Cat 1 (7/8") & 2 (1-1/8")

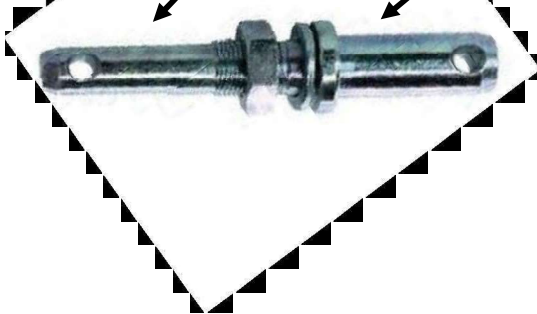

Float Position for center link pin to slot.

Hole for Rigid Position of center link.



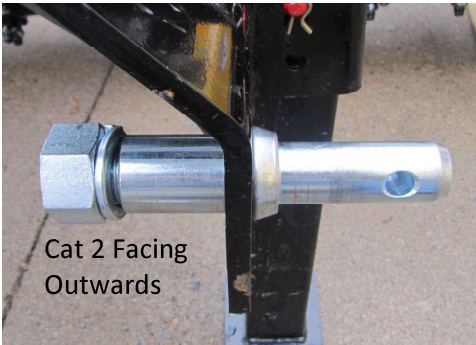

Cat 2 Facing Outwards



Cat 2 Facing Inwards

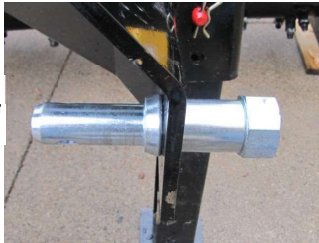

WARNING:

When removing and making adjustments to hitch pins. Make sure attaching nut is torqued down to proper specifications.

Attaching Processor to tractor. Back up tractor to processor and attach lower left and right draft arms. Check for processor category pin identification. Cat 1..2..3.. check for tractor identification category pin. Cat 1..2..3.. Make sure they are compatible. Standard Raptor and Heavy duty Raptor offers cat 1 cat 2 combo pins. Super duty features include a dedicated cat 2 pin adjustable. This pin may be adapted to cat 3 with a bushing. Category 2 inside category 3 outside. Super duty hitch is engineered and designed for several tractors and a variety of horsepower ranges. The dedicated category 2 pin may be installed on the inside or outside of the Raptors lower draft arm attaching point. Normally Category 2 installed inside category 3 installed outside. Special note: In some rare cases installing on the inside you may encounter fit-up issues. Some cat 2 draft arm eyelets have a large diameter housing, affecting fit up issues. The cat 2 pin is designed with long thread. You can install a bushing to adjust the pin outwards, then giving you clearance for the eyelet housing.

Upper center link. The Raptor features both rigid or float. Round hole is the rigid position. The elongated cutout is the flex and float position. How this works is by adjusting the center link rear/backwards will allow the Processor to float, unlike the rigid setting. The float setting will allow the processor maintain a level setting if the front tractor tires falls into a hole or ravine. If this happens on the rigid setting there's a chance the Processor may be lifted out of the ground. Second feature of the flex and float setting is if you encounter unmovable obstacles this will allow rotor to flex up so as damage to rotor shafts does not occur. In the rigid setting damage could occur. The ridged setting can also be referred to as the transport setting. In the rigid setting this will allow for a higher lift setting along with transport stabilization. It is recommended when loading the processor on to a trailer using the rigid setting.

Connecting the Raptor PTO to tractor - This is a normal industry connection.

Once the Raptor has been attached to tractor there are two methods of leveling rotor. Landscaping mode: You want a level rotor. Park your tractor / Raptor on a level surface such a concrete surface. Measure from top of rotor tube. NOT tooth. Make sure equal distance between left rotor tube and right road or tube are the same. SPECIAL NOTE: Chain case side, due to weight, there may be what we referred to as sagging. If this is encountered there are solutions. 1. install one more gauge wheel spindle spacer from the top side to the bottom side. 2. adjust tractor chain case side draft arm up. 3. side shift frame towards chain case starting point of 3 inches.

Road maintenance application. In this application it is common to crown the road. This adjustment may be made on the tractor draft arms. It is common most tractor draft arms are located on the tractor on the right hand side. Simple as cranking up and down.

Nortec tip: If your tractor is new there maybe paint in the threads. If your tractor is used and this feature has not been used in a long time it may have rusted or froze up. In both cases it is highly recommended to check this before attaching Raptor to tractor.

Nortec tip: If your tractor has a multifunction SCV you may want to look at two options. 1. center link hydraulic cylinder. This option is available through Nortec as a stocked item. Depending on your tractor Nortec through one of our vendors can order a draft arm hydraulic cylinder.

One or both of these options will allow for fingertip in cab hydraulic adjustments.



NORTEC TIP: Pivot greasing is VERY important. If not properly greased and maintained manual will be very hard if not impossible to turn. Make sure to grease both top and bottom grease fitting. After greasing pivot angle left and right several times to smear grease on pivot plate.



Pivot Point.

Check and adjust as need the hitch to frame pivot point. As wear occurs you may have to tighten up the nut to compensate for wear. This will bring the pivot point back to factory specifications.

NOTE: Over tightening will prevent turning or undo wear!



Adjustable draft arm pins. Install in either the in or out position depending on lower arm tractor design.

Leveling the Machine

To properly position the machine, the chain case should be in a vertical position. Locate the machine on a level surface. Check that the rotor is the same distance from the ground on either side. Check that the end plates are perpendicular to the ground. It is important that you have the machine leveled properly so it pulls correctly. If not level, the machine will pull crookedly, particularly when the rotor is angled.

Tractor Parts and Accessories

PTO

PTO stands for power take-off. It is a device that transfers power from a tractor's engine to an implement or machine that doesn't have its own engine. To use a PTO, you need to attach a PTO-driven implement to it and engage the PTO.

Live PTO can transfer power to implements even when the gear is not engaged. Unlike transmission PTO, live PTO has a separate clutch for engaging and disengaging the PTO. An operator can change gears or stop the tractor while the PTO is engaged because live PTO uses a 2 stage clutch.

Independent PTO is very similar to live PTO. It has its own separate clutch, which makes it possible to engage the PTO without engaging the gear. This type of PTO does not depend on any other function on the tractor. An operator can engage or disengage the PTO while the tractor is moving and also when it is stationary.



It is essential that the groove in the yoke of the PTO shaft is clean, undamaged and in good condition and the correct bearing ring is fitted so the PTO shaft guard and

DANGER: bearings can turn freely. Lubricate the bearings regularly as recommended.

Do not over grease the bearing as the excess grease will attract dirt and dust.

Tips for keeping a PTO guard and shaft in good condition:

Check the length of the telescoping members to insure the driveline will not bottom out or separate when turning and/or going over rough terrain. Also separation may/can occur when lifting 3-point hitch upward! You need at least 5" of over lap on both the male and female shafts for proper and safe operation. If the PTO shaft is too long damage to PTO joints and gear box may occur.

Length modification of the implement input driveline should only be done at the direction of the dealer.

Contact dealer if you have a question on proper PTO length.



Pay attention to the length of the PTO shaft when you first mount it. A PTO shaft that is too long will break the machine or the transmission of the tractor. A PTO shaft that is too short will fall apart in the middle.

DANGER

No power going to rotor?

If you put the processor into operating mode and rotor stalls check slip clutch for damage, such as burnt disks or if conditioning/free-wheeling nuts are fully backed out.



IF machine gets jammed and slip clutch slip.

Stop machine immediately! If you continue to operate damage to slip clutch may occur!

WARNING



Make sure PTO Shaft is the proper length.

Lift the three point hitch so that the power intake shaft of the Raptor is the same height as the PTO of the tractor. The PTO and the power intake should be closest to each other at that position.

Measure the distance between the notch of the tractor's splined shaft to the notch of the splined shaft of the Raptor. This will be the longest possible compressed length of the PTO shaft. My distance = _____ inches

Subtract two inches from this measurement. (e.g. If you measured 24 inches, you subtract 2 inches ... $24 - 2 = 22$) This number will be the compressed length of the PTO shaft. My distance _____ inches - 2 inches = _____ inches

The compressed length is 27" (EXAMPLE) inches "notch to notch." Take 27 inches and subtract your answer from (D). The difference between the two is the amount you need to cut off the tip of the two parts of the PTO shaft. (e.g. In our example we have $27 - 22 = 5$ " You would need to cut 5" inches off of both ends of the PTO shaft) 27 inches - _____ inches (answer to (D)) = _____ inches to cut off shaft

- (A) Mount the Raptor to the Power Unit (Tractor) on the 3-point hitch.
- (B) **Pay attention to the length of the PTO shaft when you first mount it. A PTO shaft that is too long will break the machine or the transmission of the tractor. A PTO shaft that is too short will fall apart in the middle.**
- (C) Be sure to cut both halves of your PTO shaft to the same length. Cut the guards to the same length as well. File sharp edges off the shaft tubes and guards so they can easily slide into one another.
- (D) Test the Range Of Motion: Raise the 3-point up to the operating point. Lower down to the machines lowest operating point. Lowest Point... Factor in machine in real life operation.

 Note: The information provided above is to be used as a guide only. NORTEC EQUIPMENT LLC takes no responsibility for any damage or

Injury caused to persons or equipment while measuring and cutting a WARNING: _____ PTO shaft.



APPROPRIATE PERSONAL PROTECTIVE EQUIPMENT (PPE)

Protective shoes with slip resistant soles
Protective glasses or goggles
Heavy gloves
Hearing protection
Respirator or filter mask

 WARNING:

Cutting PTO or Cross Over "Side Shift" Shafts

When it comes to PTO shafts for implements, there is no such thing as "one size fits all". One of the unfortunate things about selling our equipment all over the US is that we cannot cut your PTO shaft to length before it is delivered to you. That is a job that simply must be done specifically for your tractor. And for every brand and model of tractor the proper length for the PTO shaft can be different.

If the PTO shaft is too long it might bind when the three point hitch is lifted up. Damage might be caused to the Raptor or to the PTO of the tractor. If the PTO shaft is too long it must be cut. Both PTO halves must be shortened by equal amounts.

1. Mount the Raptor on the three-point hitch of the tractor. 2. Cut the engine and remove the keys. Lower the Raptor on a firm and level surface. 3. Lift the three point hitch so that the power intake shaft of the Raptor is on the same height as the PTO of the tractor. The PTO and the power intake should be closest to each other at that position. 4. Pull the PTO shaft apart. Connect one half of the shaft to the Raptor so that the locking pin is locked in place. Place the other end of the Raptor flush with the end of the tractor's PTO. Lay the ends side by side. Mark on the shield how much must be cut off.

Check the length of the telescoping members to ensure the driveline will not bottom out or separate when turning and/or going over rough terrain. Also separation may/can occur when lifting 3-point hitch upward! You need at least 5" of overlap on both the male and female shafts for proper and safe operation. If the PTO shaft is too long damage to PTO joints and gear box may occur.

Length modification of the implement input driveline should only be done at the direction of the dealer.

Check the length of the telescoping members to insure the driveline will not bottom out or separate when turning and/or going over rough terrain. Also separation may/can occur when lifting 3-point hitch upward! You need at least 5" of overlap on both the male and female shafts for proper and safe operation. If the PTO shaft is too long damage to PTO joints and gear box may occur. *Length modification of the implement input driveline should only be done at the direction of the dealer.*

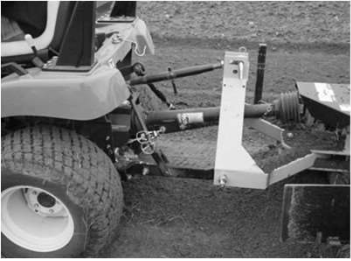

Slide the driveshaft forward and connect it to the tractor PTO shaft. Make sure the driveshaft is pushed onto the PTO shaft as far as possible and is securely locked in position.



WARNING: Cutting PTO or Cross Over "Side Shift" Shafts

When it comes to PTO shafts for implements, there is no such thing as “one size fits all”. One of the unfortunate things about selling our equipment all over the world is that we cannot cut your PTO shaft to length before it is delivered to you. That is a job that simply must be done specifically for your tractor. And for every brand and model of tractor the proper length for the PTO shaft can be different.

Properly cutting a PTO shaft, however, has traditionally been a frustrating.



NOTICE: PTO SHAFTS THAT ATTACH TO TRACTORS ARE SUPPLIED LONG ENOUGH TO FIT TRACTORS OF ALL SIZES. BECAUSE THE LENGTH OF 3 POINT HITCH ARMS ON DIFFERENT TRACTORS VARY GREATLY, IT IS LIKELY YOU WILL HAVE TO REMOVE EXCESS LENGTH FROM YOUR NEW PTO SHAFT TO FIT YOUR PARTICULAR TRACTOR.

HOW DO I KNOW IF I NEED TO CUT MY PTO SHAFT? The following are all indicators that you must shorten the PTO shaft: • It is impossible to fit the PTO shaft between the tractor and implement. • The PTO shaft can be installed, but it is an extremely tight fit due to the length. Once installed, there is less than 2 inches of the inner PTO plastic tube showing. • The implement is a type that attaches to the 3 point hitch, and you cannot install the PTO shaft without lifting the implement to its highest point of travel.

THE FIT IS TIGHT BUT I CAN INSTALL THE SHAFT. WHY MIGHT I STILL HAVE TO CUT IT? A PTO shaft uses telescoping steel tubes which naturally slide in and out as the distance from the implement changes in operation. If the tubes are too long, they can bottom out at certain angles and cause damage to the tractor or to the implement.

HOW WILL I CUT THE STEEL TUBES? The inner steel tubes can be cut with any appropriate tool with a blade that can cut metal. Common tools that are used for this purpose include: • Hacksaw • Reciprocating saw (“Sawzall”) • Metal cutting bandsaw • Grinder or other tool with a metal-cutting wheel • Any other tool that is fitted with a blade suitable to cut steel

HOW MUCH DO I CUT? To determine how much of the shaft to cut, first attach the implement to the tractor’s 3 point hitch, without the shaft installed. Adjust the 3 point hitch so that the PTO splines on the tractor and the implement are at the same height from the ground. Measure the distance from the tractor PTO notch to the implement PTO shaft notch, then subtract 2 inches from the measurement. (example, measured 24inches – 2inches = 22inches). Compress the PTO shaft completely. Measure the distance between the notches of the shaft ends. Now take the two measurements and subtract(example, measured 27inches-22inches= 5inches). This measurement is the distance needed to cut from both ends of the shaft.

Separate the shaft and mark one side on the plastic at 5 inches from the end. Cut the plastic at the mark. Then measure 5 inches from the shaft end and mark. Cut the shaft at that mark, be sure the steel shaft sticks out min .5 inches from the plastic.



from the cutting there removed.



Repeat this process so that both steel shaft halves and both plastic tubes have had the same length removed. NOTICE: DO NOT cut the steel shafts flush with the ends of the plastic tubes. The steel tubes should protrude plastic tubes the same amount as they did prior to any cutting. After will be shavings and burrs on the cut ends of all tubes that must be

Remove the filings using a metal file, sandpaper, wire wheel, or other appropriate method. Filing an angled edge on the corners is optional and will help to make insertion of the telescoping pieces easier. Wear protective gloves to prevent splinters and use a rag or paper towel to clean out any shavings from the interior and exterior of the steel tube before reassembling. Apply a thin coat of grease to the mating surfaces of both metal tubes and reassemble the shaft.



Maximum PTO Speed is Rated 540 RPM

DANGER



To lock the processor PTO onto tractor PTO, slide back collar and push onto tractor PTO. Make sure it is locked onto shaft. If implement driveshaft is not locked onto tractor PTO shaft, PTO shaft could come off.



NORTEC TIP: We have found the tractor pto shaft may have a burr on the PTO shaft making it hard or impossible to install Processor PTO shaft onto tractor. Solution: Remove burr or rust.

If tractor PTO shaft has dirt or excess grease on the shaft clean off. Also, if Raptor has dirt jammed into female connector clean off. Tractor male shaft and Raptor female shaft is manufactured at a very close tolerance and any debris may make it difficult or impossible to couple.



DANGER If any damage to PTO Shields or missing shields, REPLACE IMMEDIATELY!

PTO Entanglement Examples

Case #1: An operator finished loading a load of silage into the silo and was approaching the tractor's PTO lever to turn off the forage blower. As he stepped onto the drawbar, the laces on his boot became caught on the spring loaded push pin of the forage blower PTO driveline coupling. He was thrown backwards off the drawbar, with this boot and denim jeans being forcibly removed. He suffered considerable muscle damage to his right leg.

Case #2: A teenager was helping her family load corn onto a grain elevator when her jacket sleeve became entangled by the elevator PTO shaft. Her body was flung around the shaft and her arm was torn from its socket before the tractor could be turned off.

Case #3: A small child was killed when as an "extra rider" on his father's tractor; he slipped off the tractor and became entangled by a spinning PTO shaft. The father grabbed for the boy as he began to slip but was unable to hold him out of the shaft.

Case #4: An operator's clothing was near a spinning shaft, pulled him in, flung him around the shaft a couple of times, and then threw him clear. He sustained injuries to his head, leg, right arm, and shoulder.

PTO / Slip Clutch Driveline Safety Shields



Most incidents involving driveline result from clothing caught by an engaged but unguarded, damaged or poorly maintained driveline safety shields.

DANGER:

The reasons a driveline may be left engaged include: the operator forgetting or not being aware of the PTO driveline is engaged; seeing the PTO stub spinning but not considering it dangerous enough to disengage; or, the operator is involved in a work activity requiring PTO operation. Boot laces, pant legs, overalls and coveralls, and sweatshirts are clothing items that can become caught and wrapped around a spinning PTO stub shaft. In addition to clothing, additional items that can become caught in the PTO include jewelry and long hair. The PTO driveline is identified as a mechanical wrap point hazard and is one of the oldest and most common farm machinery hazards, referring specifically to the part of the implement (machine) drive shaft that connects to the tractor. This drive shaft is known as the implement input driveline. The entire shaft is a wrap point hazard if the driveline is unshielded or damaged.



Remove Plastic PTO Safety Shield

These "tabs" are a part of the plastic "bearing" which rides in the **PTO** shaft groove. To **remove** the outer **shield** the "tabs" need to be depressed on the end closest to the u joint, while pulling the **shield** away from the u joint.



Slip Clutch

Slip Clutch: What it does - how it works:

Bolts hold the sandwich clutch together lengthwise, using compression springs at the threaded end. Under normal usage, the spring tension keeps the sandwich rotating at the same speed as the PTO shaft. If you hit something significant with the rotating implement, the friction plate (or plates) slip against the pressure plates. That permits the tractor PTO output shaft to continue to run at normal speed without being damaged by whatever slowed down the processor rotor rotation.

This is a very important procedure. The Raptor is designed to work on a wide variety of horse power ranges and conditions. Factory clutch setting are general in nature. *It is the customers responsibility to set the clutch.*

A clutch adjusted properly is set right at the slip point in normal operating conditions. Too loose of a clutch setting, wear and clutch damage may occur. Setting the clutch too tight, there is no protection.

Letting the slip clutch get wet could rust the clutch plates. Seizing up the plates could prevent the clutch from working properly and damage the machine. Check the slip clutch periodically.

Since proper adjustment is necessary for satisfactory performance. Follow these steps. Make a trial run in the heaviest operating conditions expected. If the clutch slips noticeably, tighten the adjusting bolts no more the 1/2 turn between trial runs until clutch slippage is reduced.

Scribe a mark across the clutch facing. When subject to shock-loads, a separation of the marks will assure that clutch setting is correct.

Nortec TIP: New processor or replacement of clutch disks or replacement of slip clutch assembly may need adjustment after the first hour of operation for excessive heat build-up due to undetected slippage.

If the clutch is being rebuilt (new facing and / or plates), it is necessary to "run-in" these parts prior to final adjustment. These plates should be thoroughly cleaned and free of foreign material, as well as being checked with a straight edge for warping. Warped plates cannot be adjusted properly and will not hold.

Damage to the slip clutch could occur by running the machine too long with the slip clutch slipping. Overheating and smoking the clutch will damage the clutch plates, causing the machine to not work properly and the slip clutch will slip under working pressure. If the slip clutch slips, the plates need to be replaced. See your dealer for proper repair.

The slip clutch provides protection to prevent damage to the machine. The slip clutch will slip when something gets jammed in the rotor. Stop immediately and remove the jammed material. Disengage PTO immediately! Shut off engine (power unit), remove obstruction and re-engage power source. Make sure the rotor runs smoothly and freely.

NOTE: After the Raptor Soil Processor has been stored for an extended period of time (30 days or more), or before initial operation, perform the following operational check:

1. Loosen eight nuts retaining clutch springs 1/3 turn or until spring can be turned with fingers.
2. With tractor at idle speed, engage tractor PTO drive for 2-3 seconds. All clutch disc should slip without turning the rotor. If clutch does not slip, you have a seized / rusted clutch. Disassemble and clean/rebuild the slip clutch.
3. Retighten nuts to within 1/64" of original position.

Overtightening springs nuts may cause damage to implement and/or tractor due to incorrect slip clutch torque setting. Always follow the proper adjustment procedure.

Slip Clutch Adjustment The slip clutch is factory preset to the correct torque for protecting implement and tractor. Periodic adjustment is recommended. Should adjustment be needed, first check to be sure all spring lengths are the same. Initial compressed spring length should be slightly less than 1-1/4" or about 31.5mm. If necessary, adjust nut on any spring that is unequal. Adjust all eight spring nuts 1/3 of a turn (2 flats on a nut) and check clutch slippage. If further adjustment is necessary, do so in 1/3 turn increments. Adjust only to provide sufficient torque to prevent slippage under normal conditions. Occasional slippage is normal for drivetrain protection.

Important: When making adjustments, retighten the nuts in a star or crisscross pattern to the specified setting.

Having a slip clutch fully tensioned up is as good as having no slip clutch. It must 'slip' in order to do its job. You need to ensure the tension on all the bolts and nuts on the slip clutch is the same. A good starting point is to tighten all of the bolts and nuts up, then undo two full revolutions on each bolt.





Removing Slip Clutch

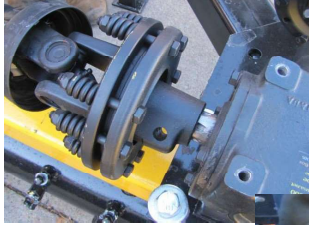

Remove Swedge bolt from clutch. Do not damage threads.



If clutch is difficult to remove, install a 2x4 as a pry bar. You may have to spin clutch to the bottom side for prying action.

Repeat if necessary.



Opposite side. Attaches and De-attaches much like the PTO on your tractor. Push button in and remove.



Reassembly: Reverse procedure.

Note: Apply Permatex "Anti Seize Lubricant" to splines.



Hydraulics Hose and Couplers TRACTOR

Hooking Up Tractor Hydraulics:

Insert hydraulic couplers like any normal tractor hydraulic coupler.

Read tractor owner's manual for proper coupling.

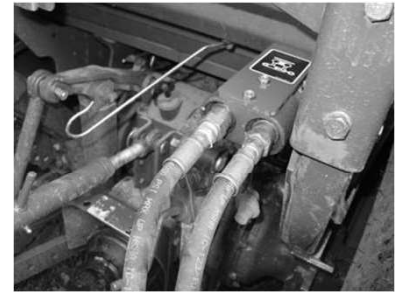

Typical Skid Steers have flat face couplers. There are different styles of flat face couplers. NORTEC offers the most common style. If NORTEC EQUIPMENT LLC supplied couplers that do not fit, see your dealer for the correct couplers.

Clean off hydraulic tips before coupling it's very important not to contaminate the hydraulics with dirt. Even though hydraulics are turned off there still could be hydraulic pressure in the system that could spray out when coupling and uncoupling.



Hydraulics Hose and Couplers SKID STEER

NORTEC TIP: To ensure the operation being the same each time you hook the hydraulics up, it's a good idea to label/mark both male and female couplers. Label/mark hydraulic flow in and flow out. Then the hydraulic will operate the same each and every time.



Clean off hydraulic tips before coupling it's very important not to contaminate the hydraulics with dirt. Even though hydraulics are turned off there still could be hydraulic pressure in the system that could spray out when coupling and uncoupling.

If any damage occurs to hydraulic hoses, REPLACE IMMEDIATELY!



NORTEC TIP: When uncoupling hydraulic couplers. Relieve pressure before uncoupling Processor. Refer to power unit owner's manual. Not doing so will make coupling difficult or impossible to recouple.





Hydraulic fluid connections can loosen due to physical damage and vibration. Check connections regularly. Tighten loose connections.



Is hydraulic fluid harmful to skin?

Skin contact is a common form of exposure to hydraulic fluid. Contact with pressurized hydraulic fluid due to leakages will cause burns. Also, prolonged continuous contact of non-pressurized hydraulic fluids in the skin will also cause irritation, redness, dermatitis, eczema and serious disease like skin cancer.

Will hydraulic fluid explode?

Yes, there are risks and a hydraulic reservoir could explode during hot repairs.

Wear Protective Gear When Handling Fluids

Some hydraulic fluids contain chemicals that can cause skin irritation if touched, as well as more serious adverse reactions if ingested or injected. It is wise to always wear gloves when working with hydraulic fluids to help prevent skin contact.

Ensure all hoses are rated above the maximum operating pressure.

Replace any hose that has exceeded service life.

Release any stored energy in the hydraulic system prior to performing inspection or maintenance work. In the event of a burst hydraulic hose, or where leakage is observed, consider the procedure of immediately shutting down the plant to avoid the further release of fluid and seek inspection by a competent person.

Skid Steer Version Mount

The Skid Steer Raptor comes with a Heavy Duty Universal Skid Steer Flex-Float mount plate.



The Flex-Float mount plate can be locked in place using two pins (one on each side of mount) as shown below. Or the pins can be removed allowing the operator to tilt forward allowing the attachment to “float” across the ground in operation. Automatically adjusts for changing landscapes. Most useful for operating on un-even or rolling terrain.



Lock Pins for “rigid” operation.

Remove pins for “float” operation.



Flex-Float in operation:

Tilt forward and raise loader accordingly to allow attachment to “float” when driving over un-even ground.

Hydraulic Drive Skid Steer Version

The S-Series features hydraulic drive. Because of the wide range of skid steers or TLB's (tractor loader backhoe)

For proper operation the power unit and motor have to be matched for customer satisfaction. The bigger the motor the more GPM (gallons per minute) and PSI needed. GPM is flow which translates into speed and PSI is pressure which translates in power. Not having a matched system will cause either dissatisfied customer or damage to processor or power unit. Bigger cu. in. motor does not mean more performance. If not matched with the correct power unit specification a small motor could mean more performance. However, matching a small motor with high-capacity power unit hydraulic system could damage processor's hydraulic motor. Damage includes blowing out seals and/or seizing motor.



Skid Steer Safe Operation



When carrying the machine or any load the loader with a skid steer, it is best to keep the loader down low and carry the load low to prevent tipping the skid steer.

to

the

and

Skid steer operators and other workers in the area need to take caution and be on the lookout for the machines moving around the worksite to prevent injury to workers.

Caution: All persons in the worksite need

keep themselves positioned away from obstructions when in close proximity to

the skid steer to prevent being pushed

potentially injured by the machine.

Chain Case



WARNING Before removing any guard, shut the engine off and remove the ignition key.

The Raptor features a low maintenance chain case. Oil filled and oil cooled. Oil requirements 80W90 gear lube. 6 oz.

Oil Checking procedure: Remove lower oil check plug / screw. Remove upper breather fitting. Fill with oil until it comes out of the bottom check plug.

CHAIN MAINTENANCE The drive chain should be inspected. New chain has a tendency to stretch, so it is necessary to check the chain tension to prevent flopping around, thus causing potential problems. Chain tension is preset. If the chain becomes excessively loose, it may be necessary to remove the 1/2 link.

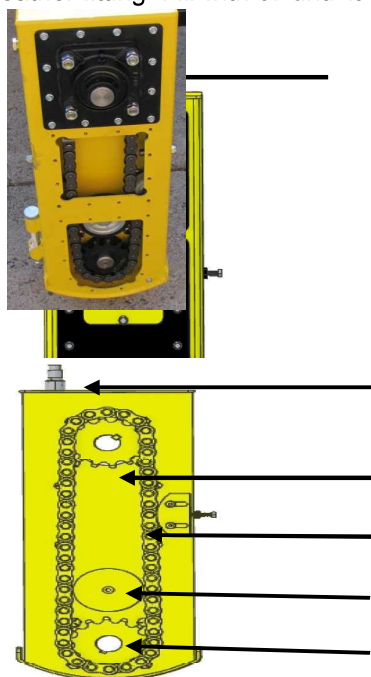

D Compensator Wheel

E Bottom Sprocket
 Checking Oil Levels:
 Remove top breather. The breather opening is now the fill point. Remove bottom. Plug, red in color. Type of oil: 80w90 Gear Lube, in hot warm weather conditions 140w Gear Lube is recommended.

A Breather

B Top Sprocket

C Chain

Alignment of top and bottom sprockets. Make sure top and bottom sprockets are equal measurement. AA & AB should be the same distance. There is no guide line and a very loose specification. Bottom sprocket need to be locked in. Meaning "NO PLAY" Solid. Shims may be installed to take up gap. Nortec parts department has them as a parts item. May be purchased locally. They are commonly known as machine washers. 1/4" to 3/8" side wall with a 1-1/2" bore. Add and shim as needed.

Capacity is 12 ounces When checking oil level. Remove bottom red plug. You should see fluid running out of opening. If not, remove breather, add a slight amount of oil. 2 ounces at a time. Watch for oil coming out of bottom hole. Keep in mind it takes a

few minutes for oil flowing down to bottom of chain case. DO NOT OVER FILL!

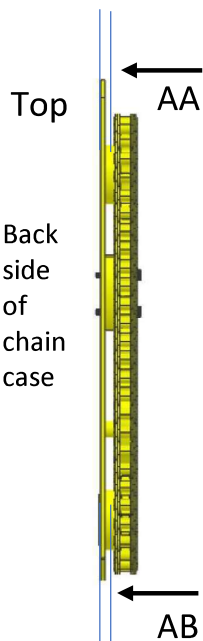

Top

AA

Back side of chain case

AB

Chain Case Attachment to Rotor

Theory of operation. 3 main components. Chain case, frame and rotor.

Chain case is connected to frame, rotor is connected to chain case. All 3 items have to work in harmony and precise alignment.

Rotor Lock Up: The most critical adjustment is the basic understanding of rotor lock up. Reason for this adjustment is to lock down the rotor so as it does not "walk" out of adjustment. If there is side push, this side push puts the bottom sprocket out of alignment with the top sprocket. Allowing the chain to side flex and run out of alignment.

Let's get started. First off the bottom chain case weldment and bearing protector housing has been removed for this example. First inspection is to take a look at the rotor hub and bearing assembly inner collar. There should be NO air gap. If there is, slide a machine washer filling the gap, this will determine how many take up washers (machine washers) are needed. The focal point is the bottom sprocket. All adjustments are made off the bottom sprocket. Note: Once all adjustments are made the rotor assembly is locked into position. This will NOT allow the rotor to "walk". Fig: CC is a take up washer, also known as a "machine washer". 1-1/2" Bore. These washers are thin in thickness and also has a very thin side wall. The amount of adjustment washers that are needed depends on the take up space needed to be filled.

Method of assembly. You will need to loosen up the non-drive rotor shaft. This will allow you to move the rotor left and right for final adjustment. There are two preferences of assembly. First is removing the chain case. Second is loosening up attaching hardware. Install rotor, install machine washers you determined needed to fill the air gap. Apply a thin amount of never seize to shaft. Slide on bearing assy. Nortec tip: Make sure the bearing assembly and sprockets slides on shaft. This will allow for easy adjustment and assembly. If need use sand paper to clean up and prepare rotor shaft surface, inside sprocket bore, inside bearing assy.

Step 2. Bolt on bearing assembly to chain case. Do not forget to install bearing protector. Once bearing assembly has been bolted onto chain case next step is to install spacer. This spacer will prevent sprocket from rubbing / jamming onto chain case side plate. If you need to make an adjustment, feel free to install a machine washer for adjustment.

Step 3: Rotate rotor, make sure it spins freely, no binding. Smooth....

Step 4: Install top sprocket.

Step 5: Install Chain - One of Nortec design criteria was for a slim line chain case. The benefit is less chain case wear and less material push out. Less damage because of the slim design. One major drawback is installing the chain. This step requires patience. Once you have correct installation angle, it goes together quite well.

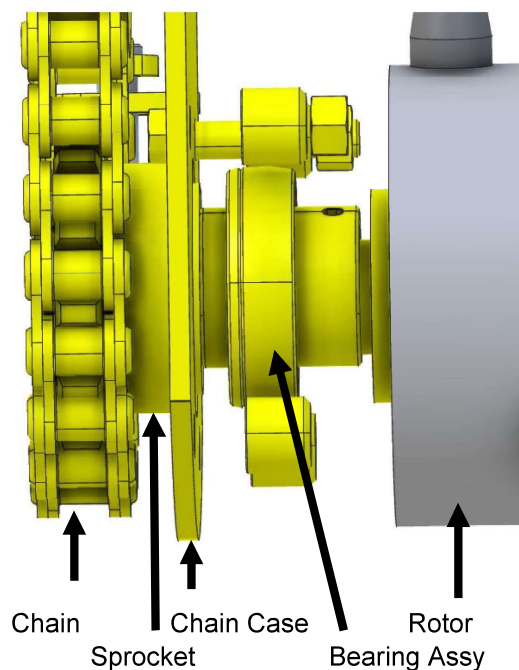
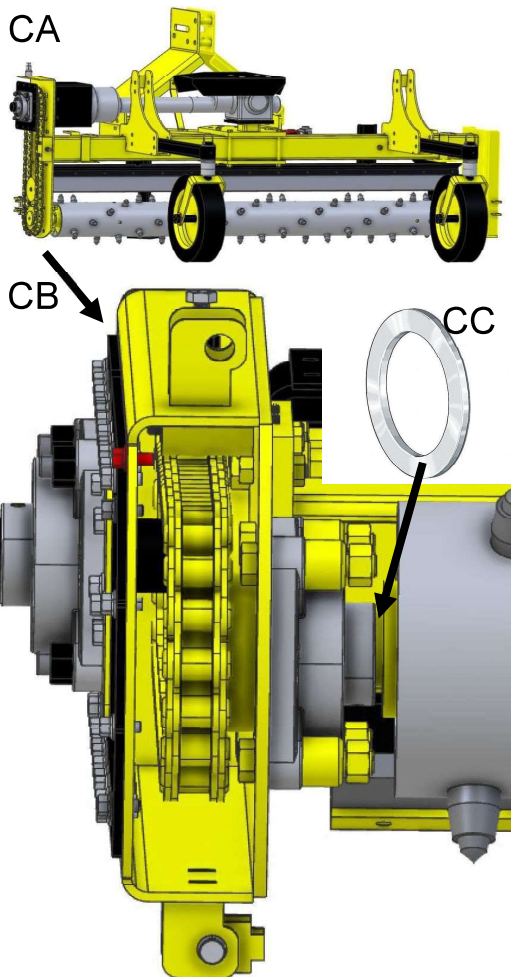

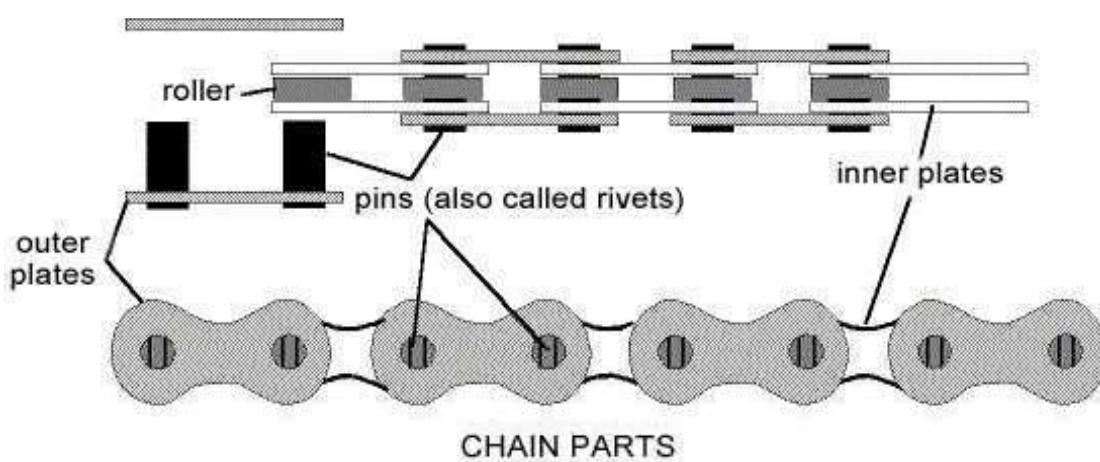

2 versions of master links may be encountered. Clip Version and Cotter Pin Version. Both are interchangeable.



#80 1/2 link. This is used in an application where as a full link causes too much slack. Taking a link out causes to short of a chain. 1/2 link is the solution.

NORTEC TIP: The master link is the weak link in the chain. It is recommended to replace the master link periodically.

Replacement chain verification method.
Count the rivets.

When to Replace Your Roller Chain

There are a few other ways besides using the chain wear gauge to know when it's time to replace a roller chain.

- 1: When the chain elongation has reached 1.5% (this may be less when using sprockets that have more than 60 teeth) Additional note: for leaf ANSI chains this can be up to 5% in some circumstances**.
- 2: When the link plate has some damage (cracking, distortions, etc.)
- 3: When any other component of the roller chain has damage (cracking, distortions, irregular movement etc.)
- 4: When the pin has bending or wrapped, or distortion of the link is found.
- 5: When substantial flex is found.

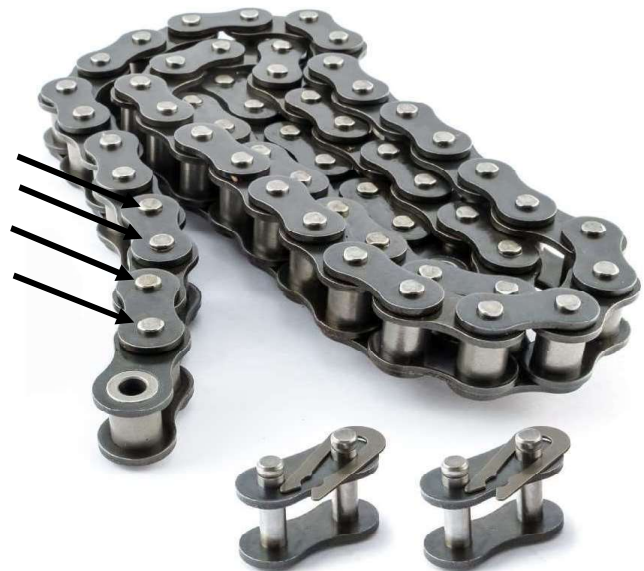

Special Note: It is common to find steel filings in the bottom of chain case. No need for concern.

Material Bar

How it works!

Figure A shows material being processed into the Processor. The rotors is loosening the material like rocks and dirt, pulling material to the surface. Materials bar is holding back the material.



The material control bar is located just above the rotor and determines how much material is going through the machine. This bar is adjustable by loosening the bolts, adjusting the bar up or down and tightening the bolts. The greater the distance between the rotor and the bar, the more material will pass over the rotor. The bar can be set down far enough to hit the teeth - you'll hear a helicopter sound when set in this position. Operating the machine in this position may cause premature wear,

but will sort out smaller debris and rocks. Adjustable with build in safety shear/slide.



Adjustable up or down for processing material over rotor and through machine. To adjust the material bar, loosen both bolts adjust either up or down. Adjusting up will let more material processing through machine adjusting down will hold back material like rocks and debris. When adjusting materials bar check both sides for levelness. When adjusting one side may make an effect on the other side.

Material bar adjuster safety system will prevent materials bar from damage. How it works: When machine is overloaded with rocks and debris the system has a break away letting the materials bar to slide up preventing damage. Re-adjust material bar and you're set to continue.

Wear safety glasses at all times. The operator/machine may pick up material like plastic sheeting, roots etc. and wrap them around rotor creating a high velocity spinning of material and throwing/shooting material into/onto operator/bystander

Removal of post, wood, lumber, stake etc. This longer material, if run through the machine, may come out and potentially hurt, kill, operator/bystander. Stop and remove the material. IMPORTANT! Make sure operator understands how to stop, shut down, shut off power source going to Raptor.

Jamming the rotor with a rock may hurt the operator/bystander by flying out and making contact. Damage may occur to property like autos, trucks, windows, buildings etc.

Preparing the Surface: In an area with a lot of tall grass, clear cut the area first, either by mowing or tilling the ground. Tall grass may have a tendency to get caught in the rotor.



End Shields / Material End Shields

The function of the end plates is to contain the material in front of the roller while the clean material passes between rotor and barrier.

Flip-up Side Shields on one end allow machine to be angled for material windrowing (such as rock and debris).

Flip-up both the Side Shields converts machine into tilling mode.

When operating in unprocessed ground/job site. Flip-up Side Shields. Hitting unexpected rocks, tree roots etc. may damage side shields. Side Shields are used on the final pass to collect surface rocks and debris.

Side Shields are NOT intended for land clearing!



Gauge Wheels "Tail Wheels"

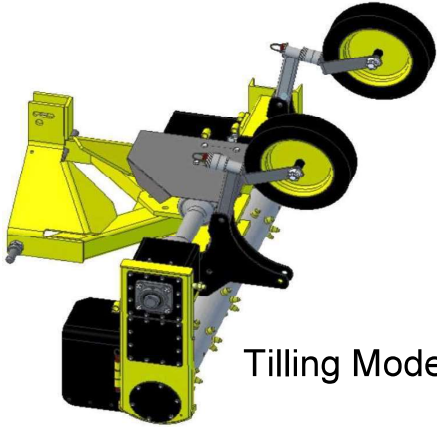

Tilling Mode:

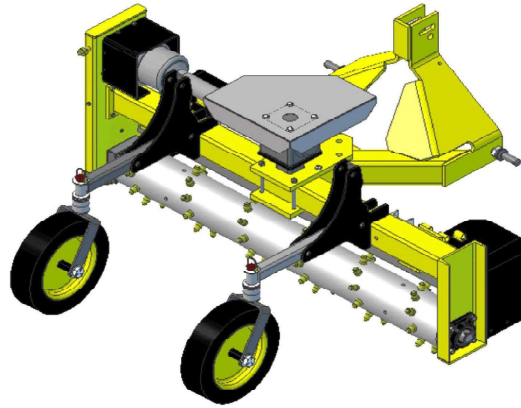

Landscaping Mode:

Flip Up Gauge Wheels

To flip up the gauge wheels, take some tension off the gauge wheels by lifting the unit up. Insert the wheel in the upright position just above its normal location for storage on the machine. The purpose of operating the machine with the gauge wheels in the up position is to allow you to get closer to buildings, etc. It also gives you more space on a trailer or in storage. The machine can be operated with one gauge wheel up and one down if you wish to slope the area you are working in. If rocks or debris accumulate between the rotor and gauge wheels, the gauge wheels should be stored in the up position to prevent wheel damage.

Super Duty Raptor features quick flip gauge wheels arms. How it works.... The mounting plate has a series of 6 hole for adjustment up or down. If that adjustment does not meet your needs, the weldment is designed with mounting the arm to plate in an offset design. This allows you to flip the assembly over to now have another 6 new adjustments for a total of 12 mounting hole adjustments.

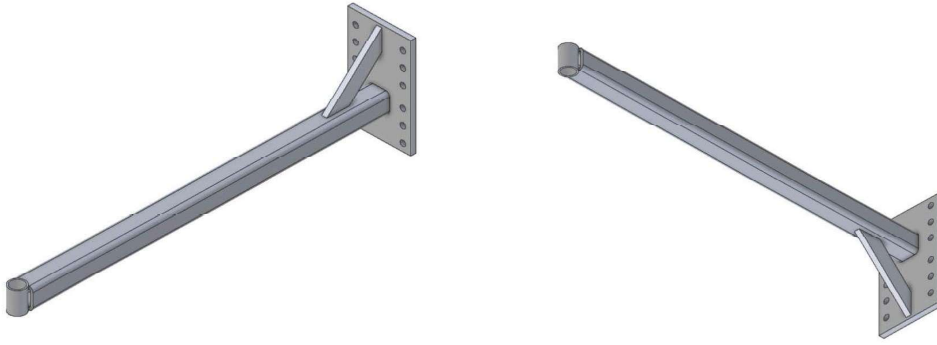



Maintenance Free, No Flat Tires: Other than greasing the axle bolt, it's a maintenance free system. No air to check, No flat tires.

Side-Shift Super Duty Frame Only

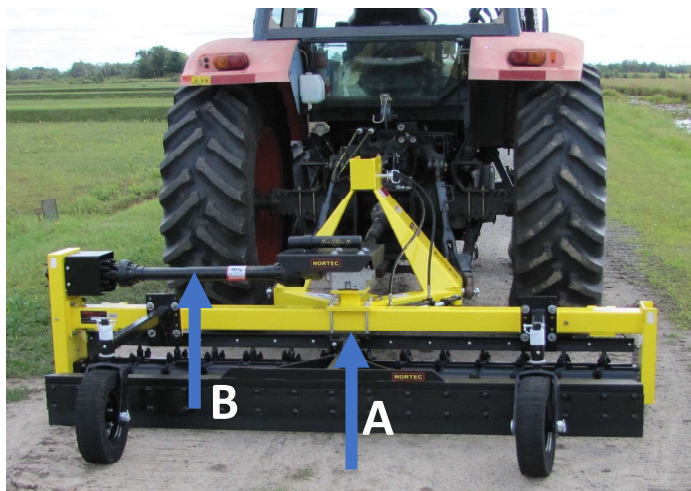

Side-Shift Adjustment: Loosen up 4 bolts on center pivot. (A) Slide main frame over to selected position. Make sure there is at least 5" of PTO shaft (B) male and female.

#2962

Angle

Rotor

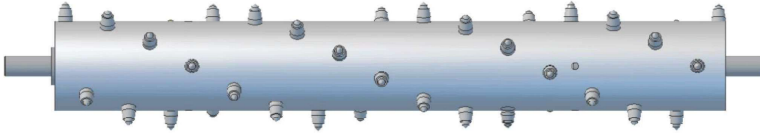

Landscaping Rotor

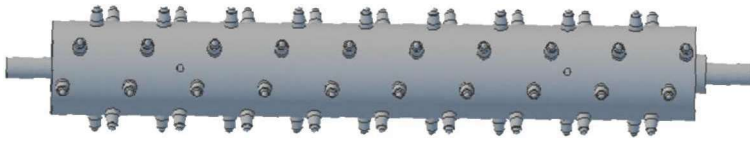

Processing Rotor



NORTEC TIP: When operating and engaging the rotor to ground contact engage PTO or Hydraulic drive and slowly make ground contact. DO NOT SLAM INTO THE GROUND Damage may occur to machine and power unit.

Rotor Wrapping

Wrapping of material such as rope, wire, roots, plastic etc. may wrap around rotor. STOP IMMEDIATELY and remove foreign material. Spinning of rotor and throwing of material may cause harm to operator/bystander!

Rotor wrapping may cause damage to bearing and bearing seals by jamming/cutting causing premature wear and damage.

Rotor Teeth

Being a ground engaging piece of equipment tooth breakage and damage can be expected. Up to 10% tooth breakage or damage should not affect machine performance.

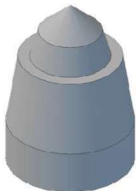

New Standard Equipment: **Aggressor TOOTH**

This Successful and Industry Leading Tooth Design is long lasting, durable and aggressive. Hard ground operation: the tooth is 75% more aggressive and reduces rotor hop by 50%. This Carbide tooth will outperform and outlast any competitors' teeth.

Rotor Bearing & Bearing / Seal Protector

Do NOT over grease! Over greasing may blow out seal, causing bearing failure.

Rotor Bearings The rotor has triple seal bearings on the left and right side. If the bearing is over-greased, the seal may blow, out allowing dust, dirt and moisture to get into the seal, thus causing fatigue. Lubricate the bearing every 75 hours. NO More than 2 shots of grease.....



Check for debris build up between rotor and frame. Also watch out for picking up foreign material like wire. Wire can work its way to the outside of rotor and get wedged between rotor and rotor bearing.

WARNING: Possible bearing damage may occur.



WARNING Before removing any guard, shut the engine off and remove the ignition key.

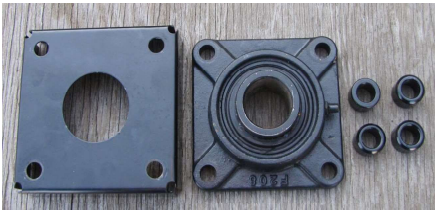



CAUTION:



Never lubricate or service machine while it's running.

INSPECTION PROCEDURE



<input type="checkbox"/>
<input type="checkbox"/>
<input type="checkbox"/>
<input type="checkbox"/>
<input type="checkbox"/>
<input type="checkbox"/>
<input type="checkbox"/>

- Machine lubricated
- Fasteners tight
- Rotor turn freely
- Chain tensioned
- All safety decals installed
- Operating and safety instructions reviewed with operator or employee
- Guards and shields installed and secured

Good maintenance is your responsibility. Poor maintenance is an invitation to trouble.

Make sure there is plenty of ventilation. Never operate the engine of the towing vehicle in a closed building. The exhaust fumes may cause asphyxiation.

Before working on the machine, stop the towing vehicle, set the brakes, disengage the PTO and all power drives, shut off the engine and remove the ignition keys.

Be certain all moving parts on attachments have come to a complete stop before attempting to perform maintenance.

Always use a safety support and block the wheels. Never use a jack to support the machine.

Always use the proper tools or equipment for the job at hand.

Use extreme caution when making adjustments.

Never replace hex bolts with less than grade five bolts unless otherwise specified. After servicing, be sure all tools, parts and service equipment are removed.

Where replacement parts are necessary for periodic maintenance and servicing, genuine factory replacement parts must be used to restore your equipment to original specifications. The manufacturer will not claim responsibility for use of unapproved parts and/or accessories and other damages as a result of their use.

If equipment has been altered in any way from original design, the manufacturer does not accept any liability for injury or warranty.

Friction is our enemy and lubrication is our ally... if applied correctly. As with any alliance, proper lubrication requires careful equipment selection and maintenance.



A grease gun is a deadly weapon capable of "killing" your equipment. Grease guns can produce up to 15,000 psi per stroke (shot); however, most bearing lip seals are unable to withstand more than 500 psi. Because of this, grease guns can generate significant pressure and, if improperly used, can ultimately blow out the seals designed to protect the bearings from external contaminants. When asked why there

WARNING: was so much grease oozing out of a bearing, an operator once replied, "If one shot is good and two is better, then isn't 50 wonderful?" No! A few well-targeted rounds are often more effective than "spray and pray." Overfilling bearing cavities can create major issues: Grease is forced outside the seals (path of least resistance) as the equipment heats up, and it is exposed to contaminants and moisture. When the equipment cools, the contaminated grease is sucked back into those same bearing cavities (part of thermal expansion and contraction) and can cause damage to the equipment. Overfilling the cavities also creates additional heat.

Grease fittings have several names, such as a Zerk fitting, grease nipple or Alemite fitting. This is the lubrication point where the grease connector is attached. The standard hydraulic grease fitting is most commonly used for standard applications. It can be either upright or angled. The button-head fitting is ideal for good coupler

engagement when large volumes of grease are being added. A flush-type grease fitting is preferred when space is limited for standard protruding fittings, while the pressure-relief vent fitting helps prevent higher pressures that could lead to **damaged seals**.

Over-greasing and under-greasing: Symptoms of over-greasing include damaged seals and environmental issues, and fluid friction, which lead to increased heat generation, higher grease oxidation rates and higher energy consumption. Symptoms of under-greasing include bearing starvation, which results in friction wear and increased contamination.

Grease Requirement: Use any high-quality, multi-purpose #2 or lithium grease



NORTEC TIP: Recommended using a grease gun with a flexible hose and pistol grip for better control.



Clean off grease fitting before greasing. NOT cleaning off grease fitting will insert/inject foreign material into system creating damage and undue wear. If grease seeps out of grease fitting and grease gun injector means grease fitting is damaged. Either remove grease fitting and clean out old dried up grease or replace grease fitting. Grease the machine when not using it for extended time or when putting it in storage for the season. Grease the machine when washing or storing it out side in the weather, this will blow out any water that may get into system and creating a seal for dirt to get into.



Anti-seize products are applied to bolts, fasteners, flanges and other clamped interfaces to prevent galling, **seizing** and corrosion, as well as **lubricating** to ease disassembly.

Using anti-seize without reducing the required torque value can strip the threads or stretch the bolt in extreme situations.

Preparing the Surface When landscaping in an area with a lot of tall grass, clear cut the area first, either by mowing or tilling the ground. Tall grass may have a tendency to get caught in the rotor.

Operation

Operating the NORTEC EQUIPMENT LLC Product The equipment should be operated with the tractor/skid steer engine speed depending on the application and operator's level of experience. Excessive speeds are dangerous, and may cause damage to equipment and unnecessary strain on tractor/skid steer.

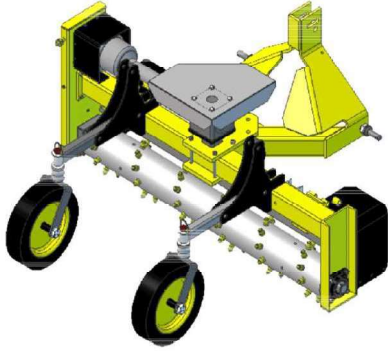

WARNING:

When transporting, run the Processor on the gauge wheels.



WARNING

Important! Be careful when operating the machine. Lifting can be dangerous. Proper machine compatibility is important. Check with power unit owner's manual for proper specifications and ballasting.



WARNING

Check and read tractor, skid steer or loader operator's manual for proper operating instructions!



DANGER

Be extra careful when working on inclines. When operating on a slope, always operate up and down the slope, never across the slope.



WARNING

Keep loader low to the ground to prevent roll over. NEVER operate with loader up in the air.



DANGER

When angling the power rake there could be side pull (rotor walking in the direction the power is directed and rotation of rotor).



DANGER

Danger! Proper length of PTO shaft, too short a PTO shaft will come off and cause personal harm or damage tractor/implement.

Make sure lower draft arm linkage is snug (tightened) up so there is no side play (rocking back and forth) relationship of implement to tractor.



WARNING

When operating or transporting, run the rake on the gauge wheels. This is done by lifting boom and tilting bucket cylinder forward running wheels on the ground.

NORTEC TIP:

- (A) Getting to the job site do a walk around. Put a plan in action on where to deposit debris like rock and unwanted material. Check for underground obstacles like electrical and utilities, property line stake, large rocks or buried concrete or ledge rock.
- (B) Start setting grade and removing debris. You do not on the first pass have complete coverage or go in a straight line. (you are roughing in job site) It's common to have material side shields up or off on the first pass to prevent damage to side shields by hitting unexpected obstacles. Also in grass or green material, opening up materials bar so material may flow through the machine. This is the material processing operation. If there's too much green material you may have to leave job site and wait for green material to dry out. After drying out the material will process much better, meaning the green material now dried out and will grind up and mix in with soil/dirt much more efficiently.
- (C) Hard pack soil. After the first pass you will notice hard spots in the job site. If not attended to you will not achieve a proper seed bed. This may be remedied by putting the Processor into the tilling mode. This is done by removing the side shields. Go around job site and take care of the trouble spots.
- (D) Put Processor back into landscape mode. Start processing the job site, set the Processor for a 2in seedbed, with the material side shields down, the material bar set close or just touching the tooth this will remove the smaller rock and debris. If job site is not to your satisfaction, repeat operation.
- (E) Final Operation - Set the Processor so the tooth is just touching the surface. Made sure side shields are running level if not material will escape under side shields leaving a windrow of unwanted material behind.

The tooth needs to be in a raking action not processing action. Raking action will remove unwanted material leaving behind processed soil. On the final operation you do not want material going over the rotor is so it will leave behind unwanted material.

Recap: If the Processor is set up right and operated correctly it will save you time and money. It takes approximately 3 to 4 landscape jobs to fully understand the benefits of the Processor. The Processor may seem to be a simple machine BUT that's not the case. If one adjustment is not correct it will not work up to your expectations and may not achieve the results you are looking for.

Do not drop soil processor into the ground with the rotor turning. Stress to the driveline, gear box or hydraulic motor can cause damage or premature wear.

Operation of the soil processor will come with operator experience and understanding. The soil processor performance also depends on the type and size of the tractor it's mounted on.

On the 3-point tractor version. Experiment with adjusting the draft arm for side to side leveling.

Tips For Applications

Pulverizing

For processing compacted soil / job site, the 3-point top link is adjusted in the lock out positions so that down pressure can be exerted on the rotor. Top link is shortened to take the guide wheels off the ground so only the rotor teeth is in contact with the ground. The soil processor can be straight or angled, with the material bar adjusted up to allow material to flow over the rotor.

Ball Fields / Athletic Sport Fields

The Raptor works great on maintaining ball fields. Blending in the infield and outfield, cutting those dangerous ledges down and blending them in are a real knee and ankle saver. Most injuries occur running backwards and tripping on the infield/outfield ledge. Another problem ball fields encounter is creating a playing surface. One that's not too soft and not too hard. Like putting down padding under your household carpeting. The Raptor being a piece of landscaping equipment we need to set grade and level the landscaping to prevent scalping of the lawn when mowing, same holds true when

processing a ball field. Maintaining a level grade will prevent water holds. To grind and blend the two surfaces together set the Raptor so the outfield side is higher than the infield side to process the material. The end shields, when starting out processing the ball field leave the end shields on so as the material will stay within the rotor and the grinding action will occur will bring along material and depositing it in the low spots acting like a box scraper. There will be lots of ridging and over flow on this step which is ok because we are loosening and processing material for the final step. The final step remove the end shield and level out rotor (side to side) the tooth should just make contact with surface. This will level out any ridging and dispersed and level the material. Leaving a finish and safe ball field. "Let's Play Ball"



Tall Grass: If there's tall grass it needs to be cut or mulched down. In either case the green material needs a few days to dry out. Then you can get back onto the job site and mulch the material into the soil.

The Raptor may be set in the landscaping mode or tilling mode. The tilling mode is important because of not having to drag along a tiller to the job site. Even if you have a tiller in the equipment fleet it takes time, labor and money get the tiller to the job site then getting it hooked up and getting the job done. Most landscapers do not use a tiller and that's wrong.

Where to use a tiller

Breaking new ground, loosening up hard spots in the job site, scrub and flower gardens, small gardens, in new home/commercial property loosening up the job site tracks. Meaning the tracks compacted by concrete and job site trucks going to and leaving the job site. These tracks are very hard and getting grass to grow is impossible without loosening up the sub surface material.

Sometimes gauge wheels in the landscaping mode just don't work

There's times gauge wheels just don't work. Example's: ditch line and banks, getting to and back grading the bottom of ditches having the gauge wheels down just don't get the job done. The gauge wheels will pick the rotor off the ground leaving behind material and filling in the ditch. Solution: Remove the gauge wheels and operate the Raptor manually.



Tips: Gravel Processing

Gravel Processing and road maintenance may be done with the Raptor.

Pot holes are a real problem. Filling them in just don't work. The rim of the pot hole needs to be cut out. This can be achieved with the Processor because of its rotor. Having power going to a rotor cuts and grinds the material. A blade just moves surface material and in most cases you need to cut and grind.

A common problem with gravel driveways/roads is that the rock type gravel gets packed down leaving behind the sand. What's happens in most cases is more gravel is brought in. By processing the existing gravel the Processor will bring the compacted gravel back to the surface and there's NO need to bring in more gravel. NOW if there is a need to bring in more gravel you need to set up the Processor properly. First, set the materials bar so more material may be processed over the rotor. The material bar needs to be adjusted for the amount of material you want to lay down. Adjusting the material bar closer to the rotor/tooth will prevent the material from flowing over the rotor. Opening up the materials bar will let more material flow through the Processor.

Materials Bar: Set the materials bar to regulate the amount of material needed to flow through the Processor

Gauge Wheels: Most driveways/roads needs a ground. This may be done by removing or adding spacers on the gauge wheels spindles. Also on tractors models the draft arms may be adjusted to pitch the hitch which in turn will pitch the rotor.

Material side shields: By leaving the material side shields on will trap and collect the material. But if you need to make more aggressive contact remove the shields. Also removing the ditch side end shields will let the rotor tooth make more contact with the soil/gravel.

Also by removing the shields will prevent you make contact with roots and other sub



end shields/material damage to the shields if ledge rocks, dead heads, surface objects.

Rain Days or Water

Holes You may open up the materials bar (A) let the material flow over the rotor (B). This fluffs up and airs out the soil. Also processing any dirt clumps by grinding them up.



Setting grade, job site leveling: Getting the job site ready is an important step. This is where you set grade, loosen up the material, start setting a 2in seed bed.



After job site has been prepped in and you find you need to bring in more dirt or sifted dirt the Raptor may be used to process and lay down the material. By using the Processor, it will break up clumps and remove any unwanted

debris.

Blending existing and processed lawn together: Set gauge wheels on one side of the machine in the Outside rotor tooth will be either just touching or not touching surface, while other side will be touching and processing the material bringing the two surfaces together.

up position, let 6" up to 12" of rotor over hang the existing lawn.

Dimpling: If water pockets are needed for water control. This may be achieved by processing the soil and setting the teeth just off the surface and let the teeth dimple the

Landscaping To Be Proud Of!

NOTE: Processing settings are a combination of all the Processor features. Material bar, side shields, gauge wheels, rotor angle, tooth action, power unit adjustments. Raking action is the setting where only the teeth are either not touching or just touching the ground. In this setting the operator needs to slow down and concentrate on driving straight, blending each and every raking pass together. In the raking mode you should have NO material going over

Final Grade: This is where it all comes together! Set the rotor teeth so they are just touching the surface. This will collect the small rock and debris. This is where the raking action occurs not the processing action. (see note)



the rotor. If so the small rock and debris will be left behind and NOT collected. Think of this as hand raking only letting the Processor do the work.

Get the job done fast and easy! If the Processor is set up and used properly you will achieve the result you are looking for.



NORTEC Safety Tip! When loading attached to the implement (Raptor) truck/trailer use extreme caution! bottom out causing the implement to ground causing a potential roll over. travel. Readjust the tractor center the problem still exists, DO NOT



the Power Unit (Tractor) and and loading onto the The tractor 3-point hitch could lift the rear wheels off the What to do to increase 3point link to achieve more travel. If LOAD tractor and power unit.



(1)	NORTEC Raptor	Getting Ready For The Season	Machine was greased for
-----	----------------------	-------------------------------------	-------------------------

the off season, now regrease with a small amount of grease as to break the seal on any dried out grease that may have dried up over the off season. **(2)** If the machine has an angle, make sure there's no rust build up on pivot points. **(3)** If machine has slip clutch condition it in for the season. See slip clutch maintenance section. **(4)** Check for correct chain case chain tension. **(5)** Run the machine for 1 to 2 minutes out on job site conditions. Let bearings reseal and reduplicate. **(6)** If machine has a PTO shaft make sure it slides in and out properly. **(7)** If machine has gear box check oil level and no leaks occur over the off season. See gear box section. **(8)** Inspect and examine that all safety decals are in excellent condition and in place.

NORTEC Raptor	Off Season Storage
----------------------	---------------------------

(1) Wash down equipment, clean all debris from machine. **(2)** Grease all grease fittings, this will push any water that got into grease area and the grease will push any water out so rust won't occur. **(3)** On tractor models check slip clutch and make any necessary adjustments. **(4)** If machine has drive chain, make sure there is no water in chain case when machine is put into storage. In cold/ freezing climates, water could freeze and damage chain case. **(5)** Check over the machine for worn or damage parts/components. Order replacement parts. **(6)** Set up an appointment with dealership shop foreman for after season or preseason check over. This will insure you will be ready and prepared for the next season. **(7)** If machine has gear box (tractor models) change oil, to remove moisture and contaminants.

Safety Tip!

NOTE: If new employees will be operating, training must be done to familiarize the operator will safety procedures and operation.



WARNING

Check List

- | | | |
|---|--|-------|
| ** Make sure proper tractor to implement specification is correct | | _____ |
| ** Check for proper implement PTO length | | _____ |
| ** Proper adjustment of sway bar/chains | | _____ |
| ** Machine free of debris | | _____ |
| ** General visual walk around of tractor and equipment inspection | | _____ |
| ** Proper servicing of tractor and implement | | _____ |
| ** Check all weld points for cracks or weld failure | | _____ |
| ** Check hoses for abrasion damage | | _____ |
| ** Check pivot points for tightness | | _____ |



<h1 style="margin: 0;">SAFETY DECAL</h1>
--

REMEMBER: If safety signs have been damaged, removed, become illegible or parts replaced without decals, new decals must be applied. New decals are available from your authorized dealer, distributor or factory.

- Keep safety signs clean and legible at all times.
- Replace safety signs that are missing or have become illegible.
- Replace parts that displayed a safety sign should also display the current sign.
- Safety signs are available from your Distributor or Dealer Parts Department or the factory.

How to Install Safety Signs:

- Be sure that the installation area is clean and dry.
- Decide on the exact position before you remove the backing paper.
- Remove the smallest portion of the split backing paper.
- Align the decal over the specified area and carefully press the small portion with the exposed sticky backing in place. Slowly peel back the remaining paper and carefully smooth the remaining portion of the decal in place.
- Small air pockets can be pierced with a pin and smoothed out using the piece of decal backing paper.

Trouble Shooting

Problem	Possible cause	Solution
Rotor not turning.	Broken master link Broken chain Sheared key in sprocket (rotor or driven) Sheared key in drive line Obstruction binding / jamming rotor Clutch need adjustment Clutch spring broken Clutch disk wore out Broken gears in gear box Broken rotor shaft Call Nortec Product Support.	Fix or Replace Fix or Replace Fix or Replace Fix or Replace Fix or Replace Adjust Fix or Replace Fix or Replace Fix or Replace Fix or Replace
	Check Skid Steer hose connections Check Tractor PTO, contact your tractor dealer	
Rotor bearing keeps going out. Rotor housing keeps breaking.	Replace with Nortec provided and high-quality bearing The Nortec housing is of ductile material if it was replaced with cast design failures will keep occurring.	
Rotor needs more gauging action	Install optional ski-shoe-runner. This will allow for another gauging point.	
Hydraulics inoperative.	Defective hydraulic couplers Hydraulic coupler not seated Check oil in power unit Broken hose Broken fitting Air in hydraulic system Check flow pressure on power unit Inadequate hydraulic pump on power unit	Fix or Replace Uncouple and recouple Check Fix or Replace Fix or Replace Cycle hyd's and or bleed system "Air" Go to a power unit with sufficient power.
	The V-Tec motor is very durable, chances are problem is not with hydraulic motor. Call Nortec Product Support before tearing motor down.	
Leaving ridges	Processor is not leveled	Adjust draft arms on tractor Readjust tilt and trim Skid Steer.tilt and trim is the bucket function.
Raptor is coming out of the ground going over hills or berms.	Re-adjust from ridged setting to float.	

I have it in float and the problem is still there.	Tractor center link is adjusted to much forward. Re-adjust center link to rear of float position.	
Chain case keeps leaking.	Remove cover, clean off old seal, re-seal. Replace Breather "pressure build up"	Fix or Replace Fix or Replace
Chain Keeps Breaking.	Wore out chain Defective master link	If hardware store master link was installed the quality is not there. Breakage will occur.
Noise in Chain Case.	Wore out sprockets. Chain slapping against side walls Wore out idler	Fix or Replace Fix or Replace or Remove a link Replace
Noise in Drive Line.	Check u-joints Key sheared Check gear box safety shield for tightness.	Fix or Replace Fix or Replace Fix or Replace
Chain case is leaving excessive ridges.	Slow down.	
Hardware keeps loosening up.	Replace Nylock nut install Lock Tight	Plastic insert is wore out
Hardware torque requirements.	Refer to "Torque Values Chart"	
Gauge wheels will not turn.	Axle bolt is to tight Rock jammed between wheel and saddle assembly.	
Gauge wheel wobbles.	Insert more downward pressure Re-position arms. Adjust arm holder / plate down.	
Hydraulic Cylinder Bent.	In severe duty applications Nortec strongly suggests to lock in turn plate. In other words, go back to manual angle.	
Angle will not hold positon.	Malfunction in manifold Solenoid cartridge	Call Nortec Product Support Fix or Replace
Nortec TIP:	Before any major tear down. Attach Raptor to another power unit to make sure the problem is not in the power unit and not the Raptor Soil Processor.	

Skid Steer plate will not hook up.	Nortec has experienced on some skid steers and tractors equipped with the Skid Steer universal attachment. The skid steer attaching plates needs to be ground down. Please call Nortec Product Support before proceeding.	
Skid Steer Flipper will not latch.	On the Raptor we have seen where some flippers are longer and the Raptor flipper slot needs to be ground out. Please call Nortec Product Support.	
Rocks are being left behind.	Re-adjust materials bar. Replace worn out materials bar rubber.	
Side Shield allowing material out leaving ridges.	Install optional ski-shoe-runner.	
Rocks keeps flowing out of front side shields.	Over capacity. Install optional ski-shoe-runner. Will increase your Raptors capacity by 30%.	
End Shields are bending.	Install optional ski-shoe-runner this will increase material thickness Also allows for a ski action to float over obstacles.	
Material bar keeps going out of adjustment.	Slider plate is bent, not allowing for contact or holding power. In the Nortec design there's a slider plate which acts as a damage control system, if you try to force too big of a rock through the processor or overcapacity of the material bar. Designed to slide up to prevent damage and expense cost to the material bar.	
Safety shield inner bearing is broken.	The chances are the PTO shaft was dropped or took a hit, or damaged in shipping. The inner bearing is a replaceable part.	Fix or Replace