

200G / 400G QSFP-DD Test Board

Part Name : LI-QSFP-DD-1X8-A1

- Operation Temp:-40~+85°C
- Support 200G / 400G QSFP-DD Transceiver
- DDMI Connection(I2C)
- Pin for Standard MSA
- 4mm Banana VCC input
- LED
- monitor(VCCT/VCCR/VCC1 /ModPrsL /InitMode/ResetL/ MODSEIL/IntL)
- Support VNA test port
- 9 fixed columns
- VS1/VS2/VS3/Res46/ePPS/ Res69 for pin connection
- Moduel installed top side

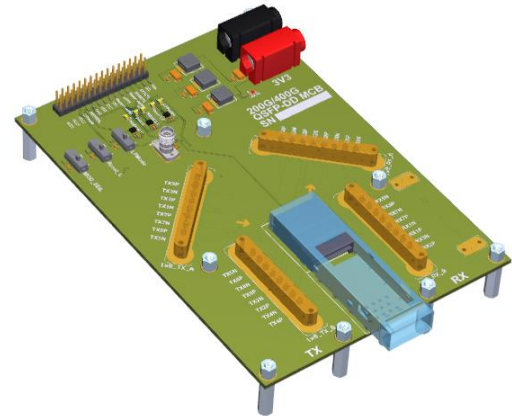

- Support QSFP- DD cage
- ePPS SMA connector
- 1x8 multi-Coaxial SMPM RF cable assembly
- Board size:160x110mm
- Connector durability:100 cycles(min)

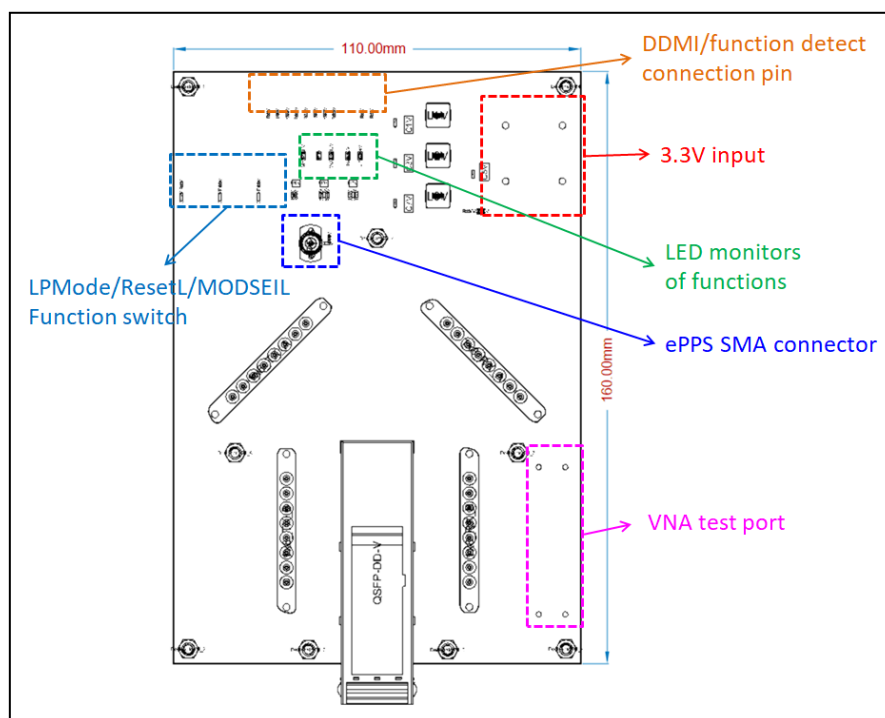



QSFP-DD module Pin definitions

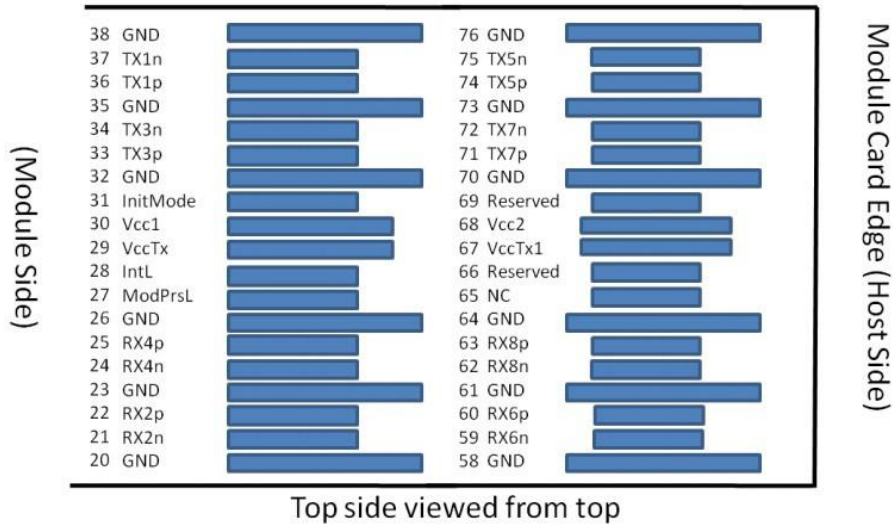

Legacy QSFP28 Pads Additional QSFP-DD Pads

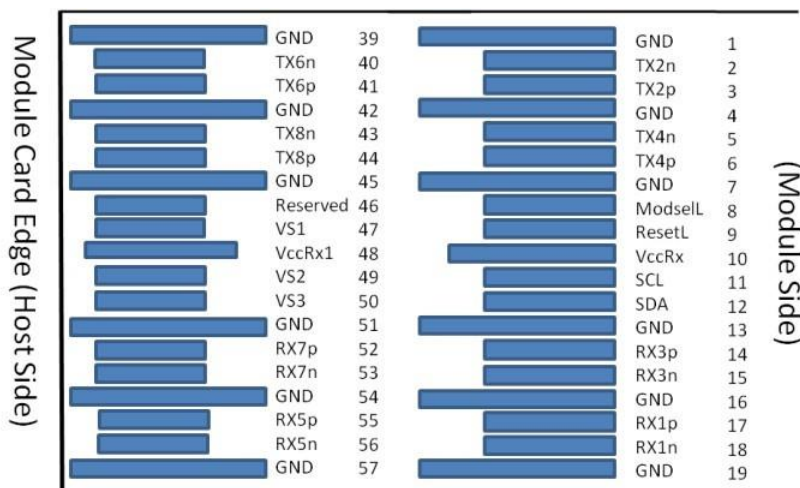

Additional QSFP-DD Pads Legacy QSFP28 Pads



Supply Filtering Network

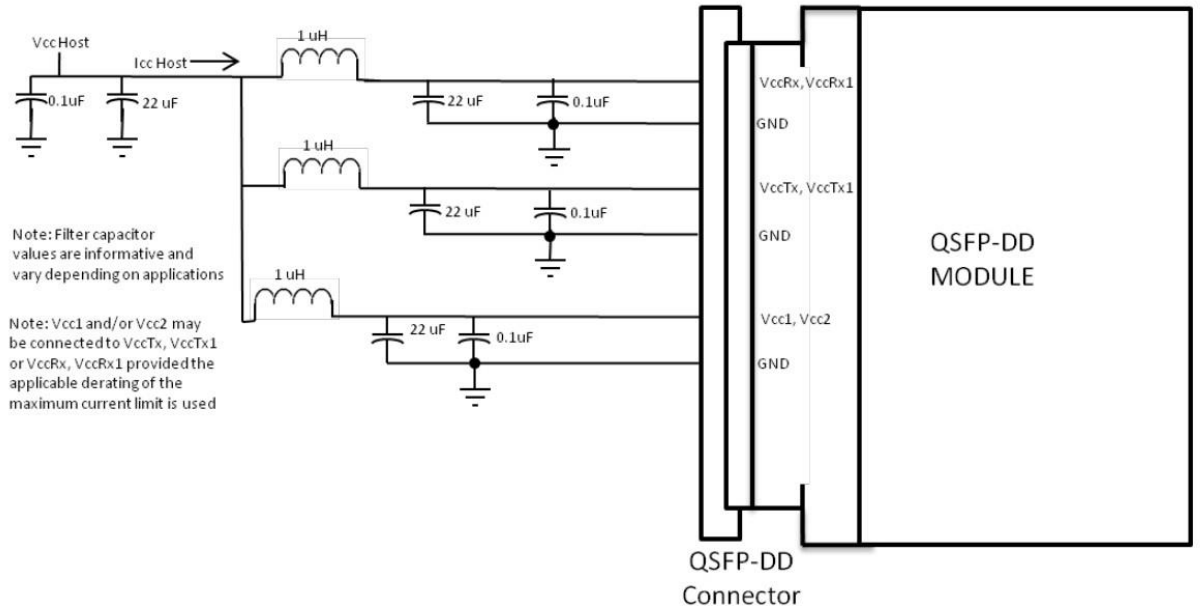



Reference Schematic

