

## QSFP+28 Test Board

Part Name : LI-QSFP28-V-A2

- Operation Temp:-40~+85°C
- Support 40G QSFP / 100G QSFP+28 Transceiver
- DDMI Connection(I2C)
- Pin for Standard MSA
- 3 types VCC input (Header pin / 4mm Banana / 2mm Banana)
- Switch control(VCCT/ VCCR/VCC1/LPMode/ ResetL/MODSEIL)
- LED monitor(VCCT/VCCR/VCC1 /ModPrsL / LPMode/ResetL/ MODSEIL/IntL)
- Support VNA test port
- 6 fixed columns
- Support QSFP+ cage
- 90 degree RF cable assembly
- Board size:130x100mm
- Connector durability:250 cycles(min)

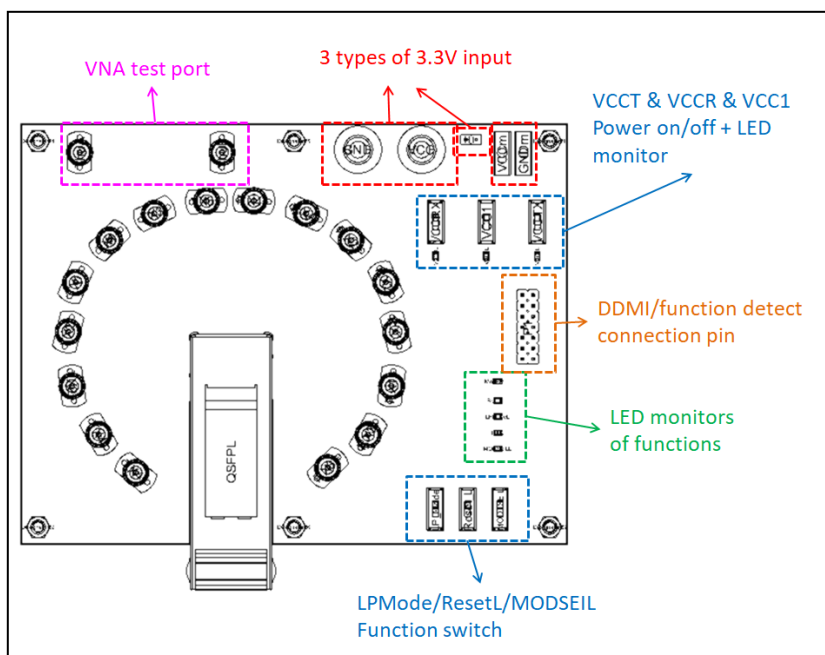

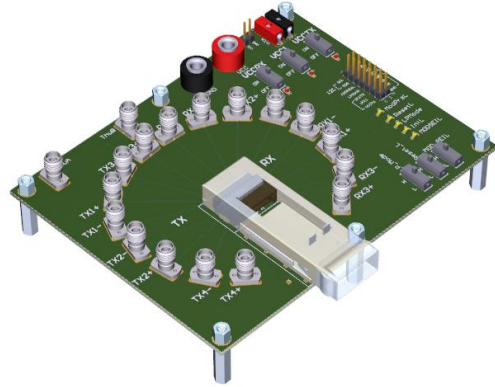

## QSFP module Pin definitions

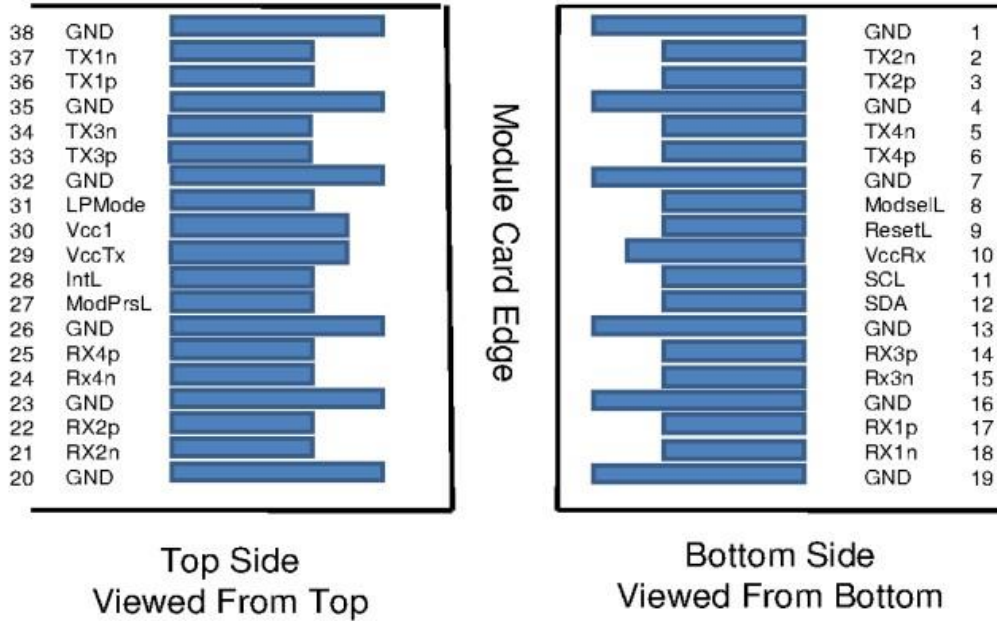

## Supply Filtering Network

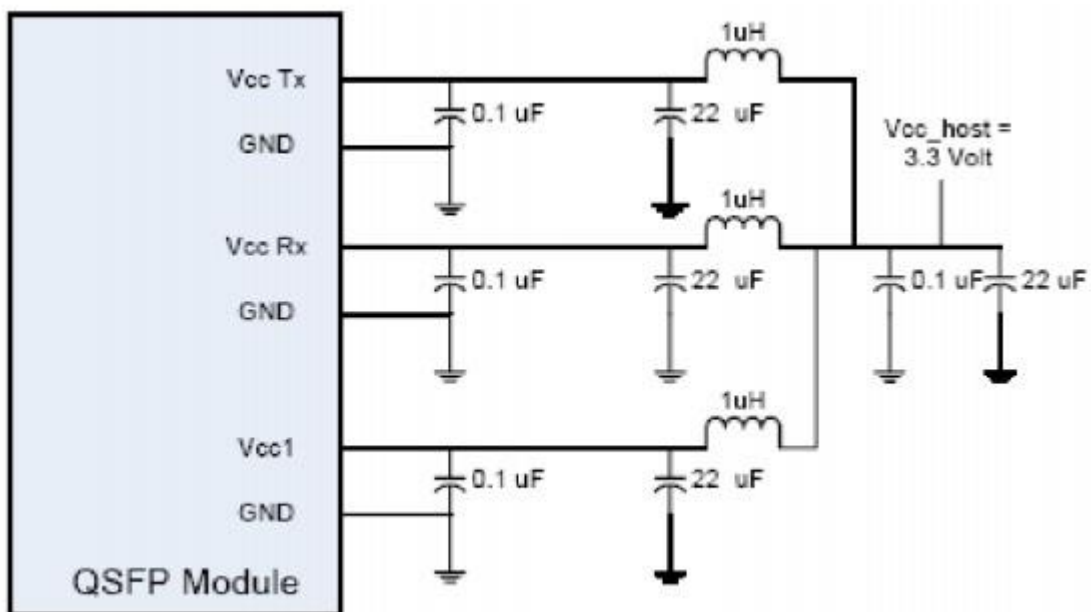



## Reference Schematic

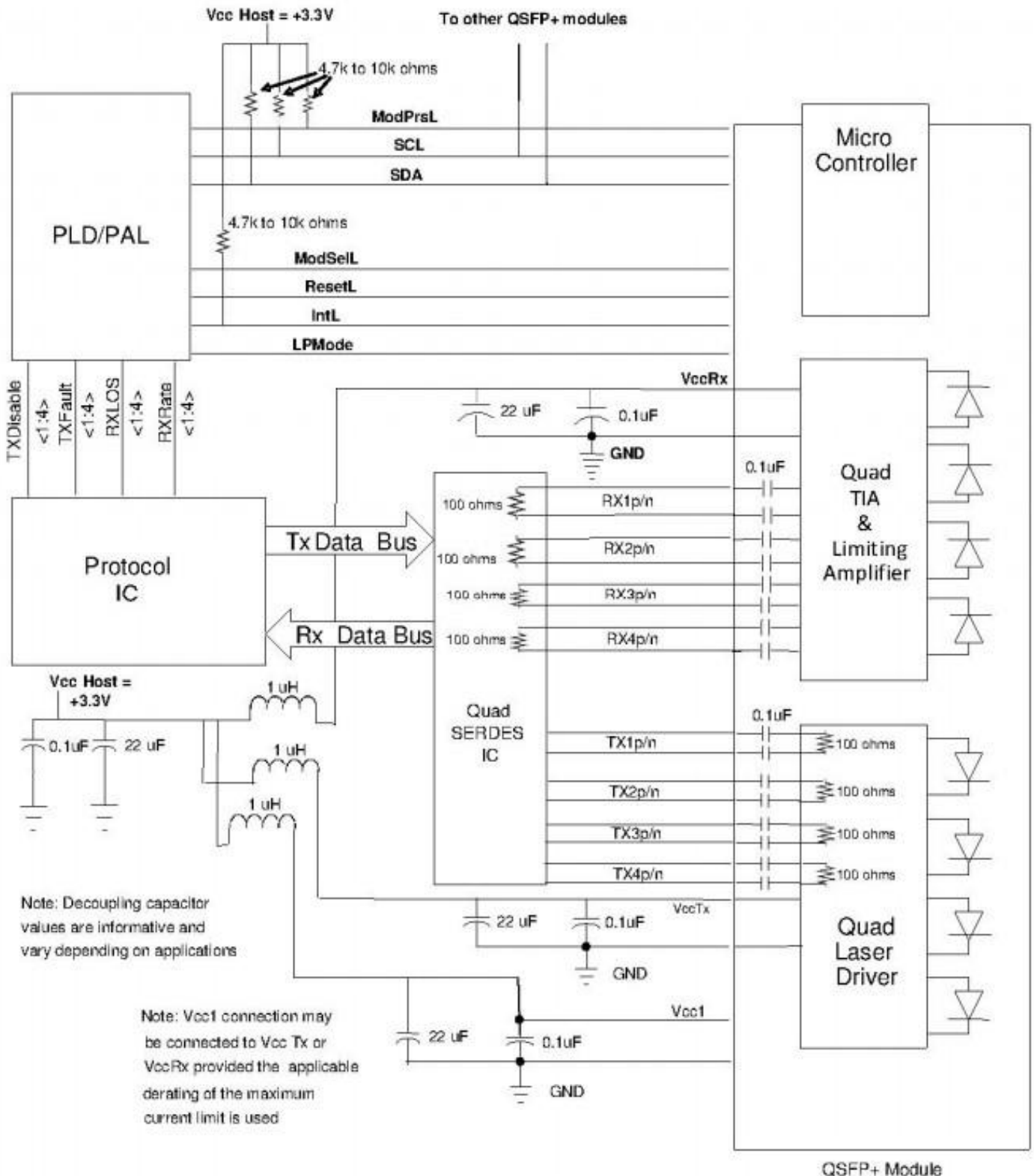

Figure 3a: Example QSFP+ Host Board Schematic For Optical Modules