



ENERGY SYSTEMS

OPERATOR'S MANUAL

CLEAN BURN MULTI-OIL FURNACE MODELS:

CB-3500 with CB-525-S2 BURNER

CB-5000 with CB-550-S2 BURNER

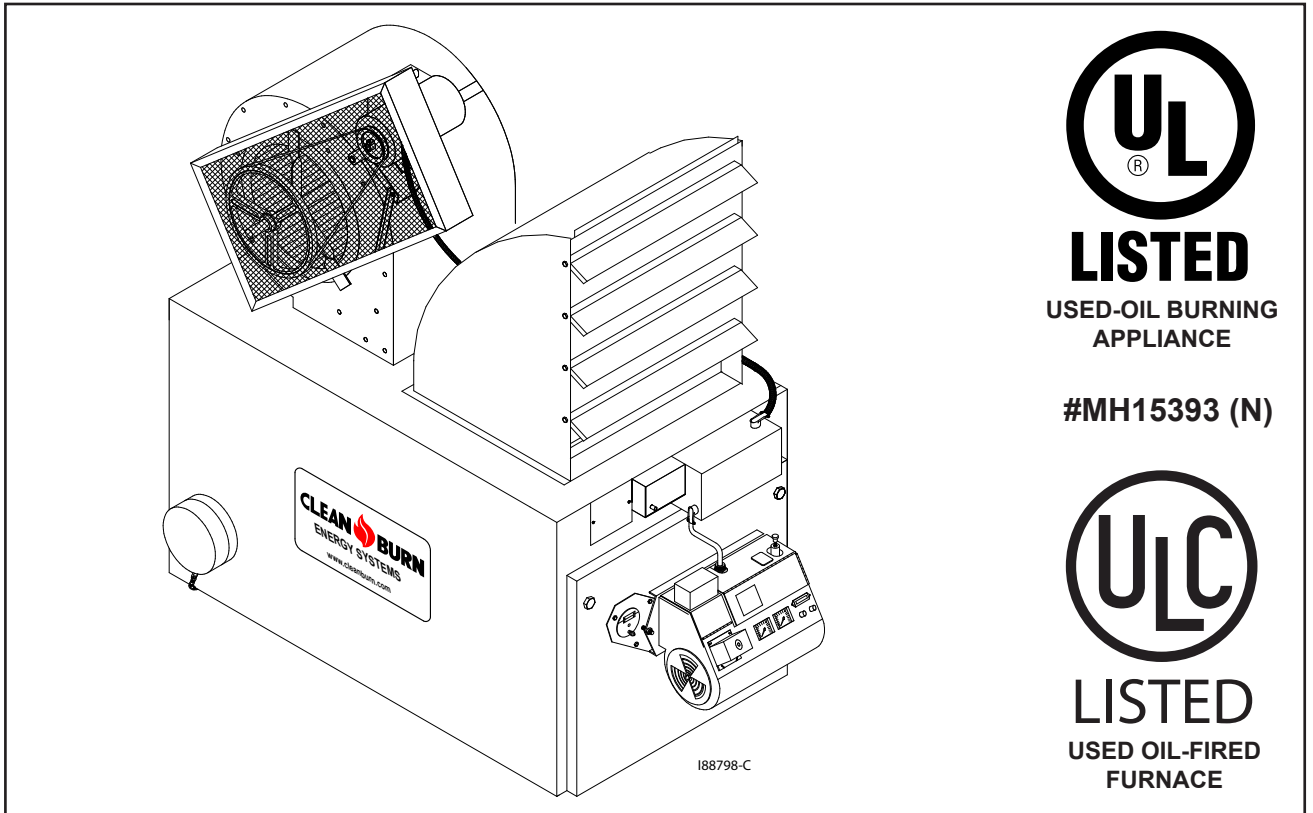

PUBLICATION DATE: 01/16/19, Rev. 16

CLEAN BURN PART #43144



WARNING: DO NOT assemble, install, operate, or maintain this equipment without first reading and understanding the information provided in this manual. Installation and service must be accomplished by qualified personnel. Failure to follow all safety precautions and procedures as stated in this manual may result in property damage, serious personal injury or death.

IMPORTANT FOR U.S. INSTALLATIONS: All installations must be made in accordance with state and local codes which may differ from the information provided in this manual. Save these instructions for reference.

IMPORTANT FOR CANADIAN INSTALLATIONS: These instructions have been reviewed and accepted by Underwriters' Laboratories of Canada as being appropriate for the installation of the ULC labelled products identified herein. The use of these instructions for the installation of products NOT bearing the ULC label and NOT identified herein may result in an unacceptable or hazardous installation.

IMPORTANT FOR CANADIAN INSTALLATIONS: The installation of this equipment is to be accomplished by qualified personnel and in accordance with the regulation of authorities having jurisdiction and CSA Standard B 139, Installation Code for Oil Burning Equipment.

CLEAN BURN

WASTE OIL FURNACE

WARRANTY INFORMATION

Clean Burn, LLC, MANUFACTURER, hereby warrants that MANUFACTURER's products shall be free from defect in material and workmanship under normal use according to the provisions and limitations herein set forth.

MANUFACTURER warrants the **heat exchanger/combustion chamber for a period of ten (10) years or 15,000 hours, whichever comes first**, from the date of purchase by the original purchaser, as follows:

If the defect occurs within the first ten (10 years or 15,000 hours, whichever comes first), Clean Burn will replace or repair the heat exchanger/combustion chamber.

MANUFACTURER warrants **all other Clean Burn component parts, including the energy retention disk**, for a period of **one (1) year** from the date of purchase by the original purchaser.

LIMITATIONS:

The obligation of MANUFACTURER for breach of warranty shall be limited to products manufactured by MANUFACTURER, (1) that are installed, operated and maintained according to MANUFACTURER's instructions furnished and/or available to the purchaser upon request; (2) that are installed according to all other applicable Federal, State and local codes or regulations; and (3) that the purchaser substantiates were defective in material and workmanship notwithstanding that they were properly installed and correctly maintained as set forth above and were not abused or misused. The MANUFACTURER may request service records or require photos of the installation or defect.

The obligation of MANUFACTURER shall be limited to replacing or repairing the defective product, at the option of the MANUFACTURER. MANUFACTURER shall not be responsible for any labor or costs or removal or reinstallation of its products and shall not be liable for transportation costs to and from its plant at Janesville, Wisconsin.

Use of parts for modification or repair of the product or any component part thereof not authorized or manufactured by MANUFACTURER specifically for such product shall void this warranty.

This warranty shall not apply to any damage to or defect in any of MANUFACTURER's products that is directly or indirectly caused by (1) force majeure, Act of God or other accident not related to an inherent product defect; or (2) abuse, misuse or neglect of such product, including any damage caused by improper assembly, installation, adjustment, service, maintenance or faulty instruction of the purchaser.

Other than as expressly set forth hereinabove, MANUFACTURER makes no other warranty, express or implied, with respect to any of MANUFACTURER's products, including but not limited to any warranty of merchantability or fitness for a particular purpose.

And in no event shall MANUFACTURER be responsible for any incidental or consequential damages of any nature suffered by purchaser or any other person or entity caused in whole or in part by any defect in any of MANUFACTURER's products. Any person or entity to whom this warranty extends and who claims breach of warranty against MANUFACTURER must bring suit thereon within one year from the date of occurrence of such breach of warranty or be forever barred from any and all legal or other remedies for such breach of warranty.

MANUFACTURER is not responsible for and hereby disclaims any undertaking, representation or warranty made by any dealer, distributor or other person that is inconsistent with or in any way more expansive than the provisions of this limited warranty.

Warranty (continued)

This warranty grants specific legal rights and shall be read in conformity with applicable state law. In some jurisdictions, the applicable law mandates warranty provisions that provide greater legal rights than those provided for herein. In such case, this limited warranty shall be read to include such mandated provisions; and any provision herein that is prohibited or unenforceable in any such jurisdiction shall, as to such jurisdiction, be ineffective to the extent of such prohibition or unenforceability without invalidating the remaining provisions and without affecting the validity or enforceability of such provision in any other jurisdiction(s).

TRADEMARKS

The Clean Burn logo is a trademark of Clean Burn, LLC. All other brand or product names mentioned are the registered trademarks or trademarks of their respective owners.

COPYRIGHT

Copyright © 2013 Clean Burn, LLC. All rights reserved. No part of this publication may be reproduced, or distributed without the prior written permission of Clean Burn, LLC. 4109 Capital Circle, Janesville, WI 53546. Subject to change without notice.

TABLE OF CONTENTS

SECTION 1: INTRODUCTION	1-1
Guide to this Manual	1-1
For Your Safety.....	1-2
Guidelines for Furnace Usage.....	1-4
Guidelines for Used Oil Tanks.....	1-5
Safety Labels.....	1-6
SECTION 2: UNPACKING.....	2-1
Removing the Shipping Crate	2-1
Unpacking and Inspecting All Components.....	2-1
Furnace Component List	2-1
Unpacking Items Packed Inside the Furnace.....	2-2
Warranty Registration.....	2-2
SECTION 3: FURNACE ASSEMBLY	3-1
Understanding Assembly.....	3-1
Required Tools and Materials	3-1
Installing the Blower Components.....	3-4
Installing the Blower (CB-5000 ONLY).....	3-4
Installing the Motor on the Blower	3-4
Wiring the Blower Motor.....	3-4
Installing the Motor Pulley, Blower Pulley, and V-Belt.....	3-6
Installing the Belt Guard and the Blower Guard.....	3-7
Installing the Hot Air Discharge Components.....	3-8
Determining the Air Discharge Configuration	3-8
UNIT HEATERS: Installing the Air Discharge Louver Assembly.....	3-9
CENTRAL FURNACES: Installing Ductwork	3-10
Installing the Energy Retention Disc.....	3-10
Installing the Energy Retention Disc in the Combustion Chamber	3-10
Closing the Furnace Door	3-10
Installing the Burner.....	3-11
Checking the Burner Nozzle and Electrodes.....	3-11
Mounting the Burner on the Hinge Bracket.....	3-12
Installing the Connector Block, Oil Line Tubing, and Air Line Tubing.....	3-13
Installing the Connector Block on the Furnace Door	3-13
Installing the Oil Line Tubing.....	3-13
Installing the Air Line Tubing.....	3-14
Locking the Burner into Firing Position	3-15
Installing the Mounting and Stabilizer Brackets	3-15
Installing the Brackets on the Furnace Cabinet	3-15

TABLE OF CONTENTS

SECTION 4: FURNACE INSTALLATION	4-1
Understanding Installation.....	4-1
Selecting a Location	4-3
Guidelines for Selecting a Location.....	4-3
Mounting the Furnace.....	4-4
Ceiling Mounting	4-4
Raised Platform Mounting	4-5
Floor Mounting	4-5
Oil Tank Installation Specifications.....	4-7
Installing the Tank Vent and Emergency Vent	4-8
Installing the Metering Pump	4-9
Preparing for Installation	4-9
Standard Mounting: Vertical Positioning	4-9
Alternate Mounting: Horizontal Positioning.....	4-11
Wiring the Furnace and Pump	4-12
Wiring to the Furnace.....	4-12
Wiring to the Metering Pump.....	4-12
Installing the Suction Oil Line Components	4-13
Installing the Pressure Relief Oil Line Back to the Tank	4-16
Installing the Pressure Oil Line Components.....	4-17
Installing the Compressed Air Line.....	4-17
Installing the Stack	4-18
Installing the Interior Stack.....	4-19
Installing the Barometric Damper.....	4-21
Installing the Stack Safety Switch For Canadian Installations	4-22
Resetting the Stack Safety Switch	4-23
Understanding the Function of the Stack Safety Switch	4-23
Installing the Stack Penetration.....	4-24
Installing the Exterior Stack.....	4-24
Installing the Stack Cap	4-24
Installing the Draft Inducer	4-24
Installing the Wall Thermostat.....	4-26
Replacing the Wall Thermostat Batteries	4-26
Inspecting the Furnace Installation.....	4-26
SECTION 5: METERING PUMP PRIMING.....	5-1
Understanding Metering Pump Priming.....	5-1
Required Tools and Materials	5-1
Priming the Metering Pump	5-2
Vacuum Testing the Oil Pump.....	5-4

TABLE OF CONTENTS

SECTION 6: STARTING AND ADJUSTING THE BURNER	6-1
Understanding Burner Startup and Adjustment.....	6-1
Preparing the Burner for Startup	6-1
Starting the Burner	6-3
Checking the Operation of the Blower Motor.....	6-5
SECTION 7: RESETTING THE FURNACE AND BURNER.....	7-1
Understanding Furnace/Burner Shutdowns.....	7-1
The Oil Primary Control.....	7-1
Resetting the Oil Primary Control	7-1
Understanding the Fan Switches and Hi-Limits.....	7-2
The Blower/Fan Switch.....	7-2
The Fan Limit Control.....	7-3
The Auxiliary Hi-Temp Limit Switch	7-4
SECTION 8: ADJUSTING THE DRAFT OVER FIRE.....	8-1
Checking for Correct Draft Over Fire	8-1
Adjusting the Barometric Damper.....	8-2
Adjusting Draft Overfire on Furnaces with Draft Inducers.....	8-2
Solving Draft Overfire Problems.....	8-3
Understanding the Effect of Exhaust Fans on Draft.....	8-3
Checking Draft Overfire to Determine Severity of Backdraft	8-3
Installing a Make-up Air Louver.....	8-5
SECTION 9: MAINTENANCE.....	9-1
Understanding Maintenance.....	9-1
Periodic Burner Inspection.....	9-2
Cleaning the Canister Filter.....	9-3
Servicing the Metering Pump.....	9-4
Cleaning the Check Valve	9-5
Cleaning the Tank.....	9-6
Cleaning Ash from the Furnace.....	9-7
Cleaning and Maintaining the Draft Inducer.....	9-9
Annual Burner Tune-up.....	9-9
End of Season Maintenance	9-9
SECTION 10: TROUBLESHOOTING.....	10-1
Flow Chart.....	10-2
Troubleshooting Tables	10-3

TABLE OF CONTENTS

APPENDIX A

Furnace Technical Specifications	A-1
Burner Technical Specifications	A-2
Furnace Dimensions	A-3
Burner Components.....	A-6
Removing the Nozzle for cleaning.....	A-13
CB-3500 Furnace Components	A-14
CB-3500 Blower Components	A-16
CB-5000 Furnace Components	A-18
CB-5000 Blower Components	A-20
Metering Pump Components.....	A-22

APPENDIX B

Wiring Diagrams	B-1
Furnace Wiring Diagram.....	B-1
Burner Wiring Diagram.....	B-2
Ladder Schematic.....	B-3
Metering Pump Wiring Schematic.....	B-4
Cad Cell Oil Primary Details.....	B-5

APPENDIX C

Furnace Service Record.....	C-1
-----------------------------	-----

SECTION 1: INTRODUCTION

Guide to this Manual

This manual contains all the information necessary to safely install and operate the Clean Burn Furnace Models CB-3500 and CB-5000. Consult the Table of Contents for a detailed list of topics covered. You'll find this manual's step-by-step procedures easy to follow and understand. Should questions arise, please contact your Clean Burn dealer before starting any of the procedures in this manual.

As you follow the directions in this manual, you'll discover that assembling and operating your new furnace involves five basic activities as outlined here:

- **UNPACKING** (Section 2)
- **ASSEMBLY** (Section 3)
- **INSTALLATION** (Section 4)
- **OPERATION**
 - **Metering Pump Priming**..... (Section 5)
 - **Starting and Adjusting the Burner**..... (Section 6)
 - **Resetting the Furnace and Burner** (Section 7)
 - **Adjusting the Draft** (Section 8)
- **MAINTENANCE** (Section 9)

The manual also contains important and detailed technical reference materials which are located at the back of the manual in the Appendixes.

Please read all sections carefully--including the important safety information found in this section--before beginning any installation/operation procedures; doing so ensures your safety and the optimal performance of your Clean Burn furnace.

WARNING!



STOP

**YOUR SAFETY IS AT STAKE!
DO NOT INSTALL, OPERATE OR
MAINTAIN THIS EQUIPMENT
WITHOUT FIRST READING
AND UNDERSTANDING THE
OPERATOR'S MANUAL!**

For Your Safety...

For your safety, Clean Burn documentation contains the following types of safety statements (listed here in order of increasing intensity):

- **NOTE:** A clarification of previous information or additional pertinent information.
- **ATTENTION:** A safety statement indicating that potential equipment damage may occur if instructions are not followed.



CAUTION: A safety statement that reminds of safety practices or directs attention to unsafe practices which could result in personal injury if proper precautions are not taken.



WARNING: A *strong* safety statement indicating that a hazard exists which can result in injury or death if proper precautions are not taken.



DANGER! *The utmost levels of safety must be observed;* an extreme hazard exists which would result in high probability of death or irreparable serious personal injury if proper precautions are not taken.

In addition to observing the specific precautions listed throughout the manual, **the following general precautions apply and *must be heeded to ensure proper, safe furnace operation.***



DANGER! DO NOT create a fire or explosion hazard by storing or using gasoline or other flammable or explosive liquids or vapors near your furnace.



DANGER! DO NOT operate your furnace if excess oil, oil vapor or fumes have accumulated in or near your furnace. As with any oil burning furnace, improper installation, operation or maintenance may result in a fire or explosion hazard.



WARNING: DO NOT add inappropriate or hazardous materials to your used oil, such as:

- Anti-freeze
- Carburetor cleaner
- Paint thinner
- Parts washer solvents
- Gasoline
- Oil additives
- Any other inappropriate/hazardous material



WARNING: Burning chlorinated materials (chlorinated solvents and oils) is *illegal*, will *severely damage* your heat exchanger, immediately *void* your warranty, and adversely affect the proper, safe operation of your furnace. Instruct your personnel to *never* add hazardous materials to your used oil.

For Your Safety... (continued)



WARNING: Never alter or modify your furnace without prior written consent of Clean Burn, LLC. Unauthorized modifications or alteration can adversely affect the proper, safe operation of your furnace.



WARNING: The burner which is shipped with your Clean Burn furnace is to be used *only* with your furnace according to the instructions provided in this manual. **DO NOT** use the burner for any other purpose!



WARNING: *The Best Operator is a Careful Operator!* By using common sense, observing general safety rules, and adhering to the precautions specific to the equipment, you, the operator, can promote safe equipment operation. ***Failure to use common sense, observe general safety rules, and adhere to the precautions specific to the equipment may result in equipment damage, fire, explosion, personal injury and/or death.***



WARNING: The installation, operation, and maintenance of this equipment in the U.S. must be accomplished by qualified personnel and in compliance with the specifications in the Clean Burn Operator's Manual and with all national, state, and local codes or authorities having jurisdiction over environmental control, building inspection and fuel, fire and electrical safety and the following standards:

NFPA 30	Flammable and Combustible Liquids Code
NFPA 30A	Automotive and Marine Service Station Code
NFPA 31	Standard for the Installation of Oil Burning Equipment
NFPA 211	Chimneys, Fireplaces, Vents and Solid Fuel Burning Appliances
NFPA 88A	Parking Structures
NFPA 88B	Repair Garages
NFPA 70	National Electrical Code

The International Mechanical Code

The International Building Code

The International Fire Code

The International Fuel Gas Code

Likewise, the installation, operation, and maintenance of this equipment **in Canada** is to be accomplished by qualified personnel and in compliance with the specifications in the Clean Burn Operator's Manual and in accordance with the regulation of authorities having jurisdiction and the following CSA Standards: B139 - Installation Code for Oil Burning Equipment;

B140.0 - General Requirements for Oil Burning Equipment; and C22.1 - Canadian Electrical Code, Part 1.

For Your Safety... (continued)

Failure to comply with these standards and requirements may result in equipment damage, fire, explosion, personal injury and/or death.

Guidelines for Furnace Usage

- This furnace is listed for commercial and/or industrial use only; it is *not* listed for residential use.
- This furnace is listed with Underwriters Laboratory (UL) and Underwriters' Laboratories of Canada (ULC) to burn the following fuels:
 - Used crankcase oil up to 50 SAE
 - Used transmission fluid (for U.S.)
 - Used hydraulic oils
 - #2 fuel oil
 - #4 fuel oil
 - #5 fuel oil

NOTE: Used oils may contain other substances, including gasoline, that may hinder performance.

- Make sure you comply with all EPA regulations concerning the use of your furnace. EPA regulations require that:
 - Your used oil is generated on-site. You may also accept used oil from "do-it-yourself" oil changers.
 - Hazardous wastes, such as chlorinated solvents, are NOT to be mixed with your used oil.
 - The flue gases are vented to the outdoors with an appropriate stack.
 - Your used oil is recycled as fuel for "heat recovery". DO NOT operate your furnace in warm weather just to burn oil.

Contact your Clean Burn dealer for current EPA regulations.





- If your furnace ever requires service, call your Clean Burn dealer. DO NOT allow untrained, unauthorized personnel to service your furnace. Make sure that your furnace receives annual preventative maintenance to ensure optimal performance.

For Your Safety... (continued)

Guidelines for Used Oil Tanks

For the safe storage of used oil and the safety of persons in the vicinity of the used oil supply tank, ensure that your tank installation adheres to the following safety guidelines:

- **The tank installation must meet all national and local codes.** Consult your local municipal authorities for more information as necessary.
- **Review and adhere to the safety guidelines for used oil supply tanks as stated in the WARNING shown.**
- Ensure that the tank for your furnace installation complies with all code and safety requirements as stated here. If the tank does not comply, **DO NOT** use it.
- If you do not have a copy of the tank safety label pictured at right, please contact your Clean Burn dealer for the label, which is to be affixed directly on your used oil supply tank.

 WARNING	
	
Fire and explosion hazards To prevent serious injury or death:	
<p>ONLY place these listed substances in this used-oil supply tank:</p> <ul style="list-style-type: none"> • Used crankcase oil • Used automatic transmission fluid • Used hydraulic oil • #2 fuel oil <p>Do NOT place flammable or corrosive substances such as gasoline, chlorinated oils, solvents, paint thinners, or any other unsafe substances in this used-oil supply tank.</p>	
<p>Do NOT weld or allow open flame within 35 feet of this used-oil supply tank.</p>	
<p>Tank installation MUST comply with NFPA 30 and 31 Fire Codes, including the following requirements:</p> <ul style="list-style-type: none"> • Tank must be listed to UL 80 or UL 142. • Tank must be vented to outside. • Emergency vent or explosion relief must be installed on tank. • Inside fill allowed only with funnel including 1/4 turn-to-close fall valve, which must be closed after filling. • All other openings must be plugged • All oil lines must be constructed of copper, steel, or brass components. Do NOT use rubber or plastic tubing or piping, or any other inappropriate material. 	
	<p>Follow all instructions for tank installation in Operator's Manual.</p>
42366 Rev. 2	

For Your Safety... (continued)

Safety Labels

Following are the locations and descriptions of all labels on your CB-3500 or CB-5000 furnace. The following illustrations show the location of ALL labels on your furnace. Please note that some labels denote model number, model description, etc. while others contain important safety messages.

Each **Safety Label** contains an important safety message starting with a key word as discussed earlier in this section (e.g. ATTENTION, CAUTION, WARNING, DANGER). For your safety and the safe operation of your furnace, review all labels and heed all safety messages as printed on the labels.

If any labels on your Clean Burn furnace ever become worn, lost or painted over, please call your Clean Burn dealer for free replacements.

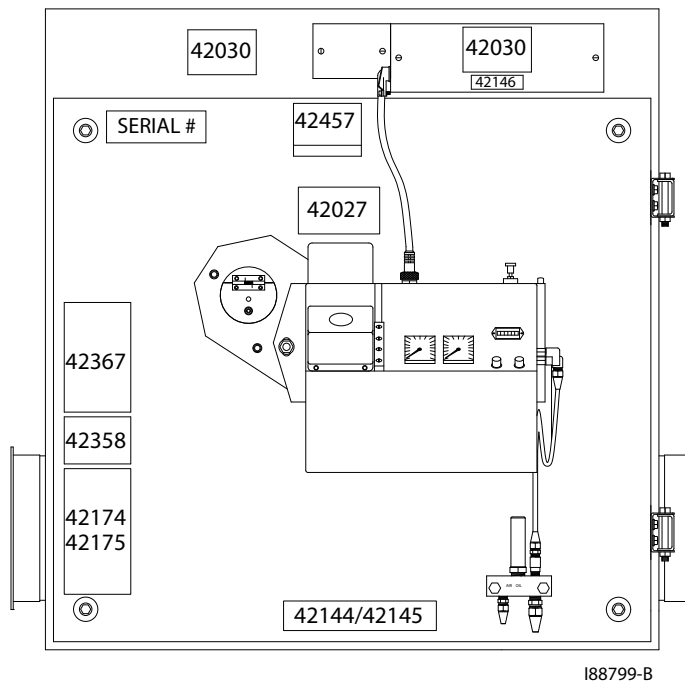





CB-3500/CB-5000 Furnace Cabinet Labels



<u>Label Part #</u>	<u>Description</u>
42030	Furnace Electrical Shock Hazard Warning Label (<i>several locations</i>)
42457	Made in USA / Patent Pending Combination Label
42027	Furnace Burn Hazard/Hazardous Voltage Warning Label
42367	Furnace Safety Warning Label (Multiple Messages - Fire/Shock/Burn Hazards)
42358	UL / ULC Header Label
42174	Data Label - CB-3500
42175	Data Label - CB-5000
42497	Clean Burn Logo Label (<i>not shown - positioned on side of unit</i>)
42144	Model CB-3500 Label
42145	Model CB-5000 Label
42146	220V Label
42068	Furnace Blower/Fan Entanglement Hazard Warning Label (<i>not shown - positioned on top of unit near blower</i>)

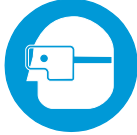

For Your Safety... (continued)

Furnace Cabinet Safety Labels

 WARNING
<p>Hazardous voltage.</p> <p>To prevent serious injury, shut OFF main power to unit before removing cover.</p> <p>Line voltage is present on most subbase terminals when power is ON. If the furnace is not wired correctly, fire, shock or damage could result.</p> <ul style="list-style-type: none"> • ONLY a qualified electrician should wire this furnace. • ONLY use copper conductors.
<small>42030 Rev. 2</small>

 WARNING
<p>Fire, explosion and burn hazards:</p> <p>Maintain clearances from combustibles as listed on unit. ONLY burn used crankcase oil, automatic transmission fluid, hydraulic oil, or #2 fuel oil. NEVER burn any other substances in this unit.</p>
<div style="display: flex; justify-content: space-around;">    </div> <p>Hot gases and ash may be released when inspection port is opened.</p> <ul style="list-style-type: none"> • Wear safety goggles and hand protection when opening inspection port. • Keep face away and open port slowly.
<p>To avoid possible injury, death, or equipment damage, read and understand operator's manuals and all safety precautions before installing, operating, or servicing this equipment.</p> 
<small>42367 Rev. 2</small>

 	 WARNING
	<p>Burn Hazard. Hazardous Voltage.</p> <p>Burner may fire at any time. Disconnect burner power cord before swinging open burner or clean-out door.</p>
	<small>42027 Rev. 2</small>

 	 WARNING
	<p>Entanglement and cutting hazard.</p> <p>Blower can start at any time. Turn power OFF before servicing. Do NOT operate without guard in place.</p>
	<small>42068 Rev. 2</small>

For Your Safety... (continued)

CB-3500/CB-5000 Furnace Cabinet Safety Labels

MODEL NO.

INPUT RATING W/NO 2 FUEL OIL (BTU/HR)

LISTED FUELS	UL INPUT	ATOM AIR PRESSURE	OIL PRESSURE
	- GPH -	- PSIG -	- PSIG -
NO 2 OIL	<input type="text" value="2.5"/>	<input type="text" value="16.0"/>	<input type="text" value="7.0"/>
USED CRANKCASE OIL	<input type="text" value="2.5"/>	<input type="text" value="16.0"/>	<input type="text" value="9.5"/>
HYDRAULIC OIL	<input type="text" value="2.5"/>	<input type="text" value="16.0"/>	<input type="text" value="8.0"/>
ATF	<input type="text" value="2.5"/>	<input type="text" value="16.0"/>	<input type="text" value="8.5"/>

MODEL NO.

INPUT RATING W/NO 2 FUEL OIL (BTU/HR)

LISTED FUELS	UL INPUT	ATOM AIR PRESSURE	OIL PRESSURE
	- GPH -	- PSIG -	- PSIG -
NO 2 OIL	<input type="text" value="3.6"/>	<input type="text" value="18.0"/>	<input type="text" value="3.5"/>
USED CRANKCASE OIL	<input type="text" value="3.6"/>	<input type="text" value="18.0"/>	<input type="text" value="4.5"/>
HYDRAULIC OIL	<input type="text" value="3.6"/>	<input type="text" value="18.0"/>	<input type="text" value="4.0"/>
ATF	<input type="text" value="3.6"/>	<input type="text" value="18.0"/>	<input type="text" value="4.0"/>

MAX. DISCHARGE AIR TEMP-F FLUE DRAFT IN W.C.

CLEARANCE TO COMBUSTIBLE SURFACES: (INCHES)

TOP	<input type="text" value="18"/>	CHIMNEY	<input type="text" value="18"/>	SIDES	<input type="text" value="24"/>
FRONT	<input type="text" value="60"/>	REAR	<input type="text" value="18"/>	BOTTOM	<input type="text" value="24"/>

MAX. DISCHARGE AIR TEMP-F FLUE DRAFT IN W.C.

CLEARANCE TO COMBUSTIBLE SURFACES: (INCHES)

TOP	<input type="text" value="18"/>	CHIMNEY	<input type="text" value="18"/>	SIDES	<input type="text" value="24"/>
FRONT	<input type="text" value="60"/>	REAR	<input type="text" value="18"/>	BOTTOM	<input type="text" value="24"/>

	POWER	VOLTS	AMPS	HZ
BLOWER MOTOR HP.	<input type="text" value="2"/>	<input type="text" value="208/230"/>	<input type="text" value="11.3/11"/>	<input type="text" value="60"/>
OIL PUMP MOTOR HP.	<input type="text" value="1/6"/>	<input type="text" value="120"/>	<input type="text" value="3.2"/>	<input type="text" value="60"/>
BURNER MOTOR HP.	<input type="text" value="1/10"/>	<input type="text" value="120"/>	<input type="text" value="1.4"/>	<input type="text" value="60"/>
BURNER HEATER WATTS	<input type="text" value="400"/>	<input type="text" value="120"/>	<input type="text" value="3.3"/>	<input type="text" value="60"/>
DRAFT IND. (OPT) HP	<input type="text" value="1/3"/>	<input type="text" value="120"/>	<input type="text" value="3.9"/>	<input type="text" value="60"/>
AIR COMPRESS. (OPT) HP.	<input type="text" value="1/3"/>	<input type="text" value="120"/>	<input type="text" value="3.5"/>	<input type="text" value="60"/>
TOTAL CIRCUIT AMPACITY W/BLOWER (UNIT HEATER)	<input type="text" value="26.6/26.3"/>			
MAXIMUM FUSE SIZE	<input type="text" value="35/35"/>			
TOTAL CIRCUIT AMPACITY W/BLOWER (CENTRAL FURNACE)	<input type="text" value="26.6/26.3"/>			
MAXIMUM FUSE SIZE	<input type="text" value="35/35"/>			

	POWER	VOLTS	AMPS	HZ
BLOWER MOTOR HP.	<input type="text" value="2"/>	<input type="text" value="208/230"/>	<input type="text" value="11.3/11"/>	<input type="text" value="60"/>
OIL PUMP MOTOR HP.	<input type="text" value="1/6"/>	<input type="text" value="120"/>	<input type="text" value="3.2"/>	<input type="text" value="60"/>
BURNER MOTOR HP.	<input type="text" value="1/10"/>	<input type="text" value="120"/>	<input type="text" value="1.4"/>	<input type="text" value="60"/>
BURNER HEATER WATTS	<input type="text" value="400"/>	<input type="text" value="120"/>	<input type="text" value="3.3"/>	<input type="text" value="60"/>
DRAFT IND. (OPT) HP	<input type="text" value="1/3"/>	<input type="text" value="120"/>	<input type="text" value="3.9"/>	<input type="text" value="60"/>
AIR COMPRESS. (OPT) HP.	<input type="text" value="1/3"/>	<input type="text" value="120"/>	<input type="text" value="3.5"/>	<input type="text" value="60"/>
TOTAL CIRCUIT AMPACITY W/BLOWER (UNIT HEATER)	<input type="text" value="26.6/26.3"/>			
MAXIMUM FUSE SIZE	<input type="text" value="35/35"/>			
TOTAL CIRCUIT AMPACITY W/BLOWER (CENTRAL FURNACE)	<input type="text" value="26.6/26.3"/>			
MAXIMUM FUSE SIZE	<input type="text" value="35/35"/>			

BURNER REQUIRES A MINIMUM AIR SOURCE OF 2 S.C.F.M. AT 25 P.S.I. THIS APPLIANCE IS NOT TO BE USED WITH AIR FILTERS AND SHALL INCORPORATE NO PROVISIONS FOR MOUNTING AIR FILTERS. INSTALL AND USE ONLY IN ACCORDANCE WITH THE MFR'S INSTALLATION AND OPERATING INSTRUCTIONS. FOR COMMERCIAL OR INDUSTRIAL USE ONLY.

AUTHORITIES HAVING JURISDICTION SHOULD BE CONSULTED PRIOR TO INSTALLATION

42174 - R1

BURNER REQUIRES A MINIMUM AIR SOURCE OF 2 S.C.F.M. AT 25 P.S.I. THIS APPLIANCE IS NOT TO BE USED WITH AIR FILTERS AND SHALL INCORPORATE NO PROVISIONS FOR MOUNTING AIR FILTERS. INSTALL AND USE ONLY IN ACCORDANCE WITH THE MFR'S INSTALLATION AND OPERATING INSTRUCTIONS. FOR COMMERCIAL OR INDUSTRIAL USE ONLY.

AUTHORITIES HAVING JURISDICTION SHOULD BE CONSULTED PRIOR TO INSTALLATION

42175 - R1



Clean Burn Energy Systems
4109 Capital Circle
Janesville, Wisconsin 53546
1-800-331-0183
www.cleanburn.com

Serial No. CB-XXXX-XXXXX
Model No. CB-XXXX

© 2013 Clean Burn LLC P/N XXXXX

CLEAN BURN LLC
JANESVILLE, WISCONSIN (USA)

MH15393



LISTED



USED-OIL BURNING APPLIANCE USED OIL-FIRED FURNACE
USED OIL-FIRED BOILER
For use with Integral Primary Safety Control

NO.

MULTI-OIL HEATING SYSTEM

INSTALL AND USE ONLY IN ACCORDANCE WITH THE MFR'S INSTALLATION AND OPERATING INSTRUCTIONS. FOR COMMERCIAL OR INDUSTRIAL USE ONLY.

AUTHORITIES HAVING JURISDICTION SHOULD BE CONSULTED PRIOR TO INSTALLATION.

CERTIFIED TO ELECTRICAL AND FUEL BURNING REQUIREMENTS ONLY. 42358

For Your Safety... (continued)

CB-3500/CB-5000 Burner Labels

Label

Part # Description

42005	Sold and Serviced By Label
42004	Burner Safety Warning Label (High Voltage/Moving Parts Hazards)
42000	Burner Safety Warning Label (Fire/Explosion Hazard - Reset Button)
42235	Burner Safety Warning Label (Fire/Explosion Hazard - Burner Installation and Service)
42321	CB-525-S2 Burner Model/Serial Number Label
42322	CB-550-S2 Burner Model/Serial Number Label
42197	Made in USA / Patent Pending Combination Label <i>(not shown - positioned on side of burner)</i>
42229	Logo/Burner Description Label
42023	Burner Power Label

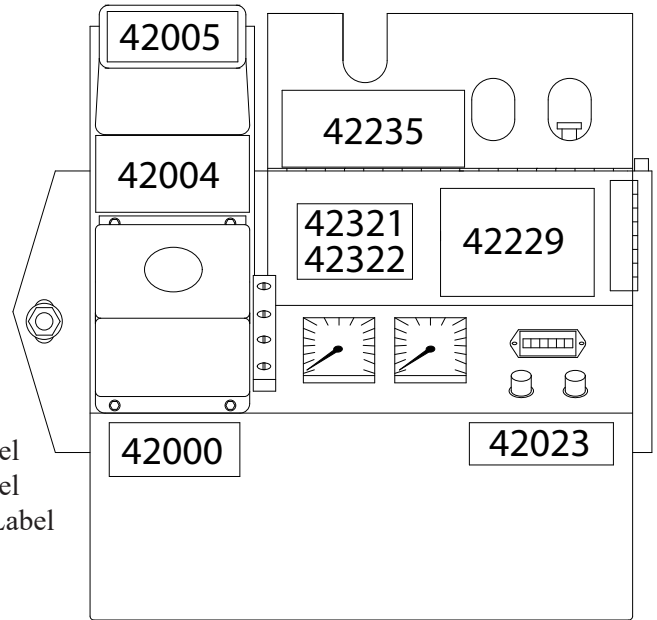

188800-B

CB-3500/CB-5000 Burner Safety Labels

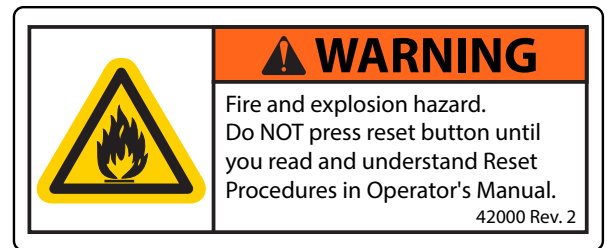
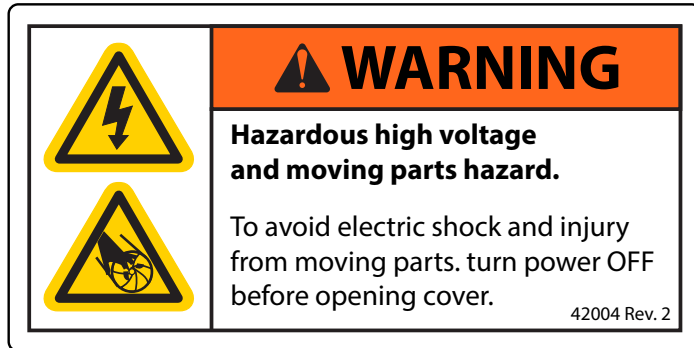

SECTION 2: UNPACKING

Before assembling your furnace, you must accomplish the following activities described in this section:

- Removing the Shipping Crate
- Unpacking and Inspecting All Components
- Warranty Registration

Removing the Shipping Crate

1. Carefully remove the top boards of the shipping crate. Then remove the front, back, and side panels.
2. Carefully lift the furnace off the shipping pallet with a fork lift.

ATTENTION: DO NOT attempt to slide the furnace cabinet out of the shipping crate--you may damage the furnace cabinet.

NOTE: DO NOT remove the squirrel cage blower from the furnace cabinet. (The blower is installed in final position for Model CB3500; it will require additional installation for Model CB5000.)

Unpacking and Inspecting All Components

Following is an itemized list of all components you should have received in your Clean Burn furnace shipment. Open all shipping containers and inspect all components according to the list. Immediately notify the freight company and your Clean Burn dealer in case of shipping damage or shortage(s). Keep all components together so you will have them as needed for furnace assembly and installation.

Furnace Component List (CB-3500 and CB-5000)

ONE SKID containing:

- Furnace cabinet

Components packed on top of furnace cabinet:

- Burner
- Blower
- Oil pump: Metering Pump OR J-Pump
 - *includes suction oil line fittings package*
- Air discharge
- Draft inducer (CB-5000 only)

Components packed inside furnace cabinet:

- Energy Retention Disc
- 2 HP Blower motor
- Vacuum gauge
- Wall thermostat
- Connector block
- Operator's Manual literature packet
 - *includes tank safety label*
- Assorted bolts/fittings, Assembly parts, Mounting components
- Blower assembly components
- Canister filter
- Check valve / check valve screen
- Barometric damper
- Burner oil line and air line components

NOTE: You may have received additional boxes or skids if you ordered optional accessories.

Unpacking Items Packed Inside the Furnace

To unpack the items packed inside the furnace cabinet (in the combustion chamber), you will need to open the combustion chamber door.

1. Remove the four nuts and washers which hold the combustion chamber door closed. Set the nuts and washers aside in a safe place for later re-installation after the Energy Retention Disc has been installed (Section 3).
2. Carefully swing the combustion chamber door open. Remove and inspect the components packed inside.
3. Leave the door unfastened (open) for assembly/installation procedures to be accomplished in the next section.

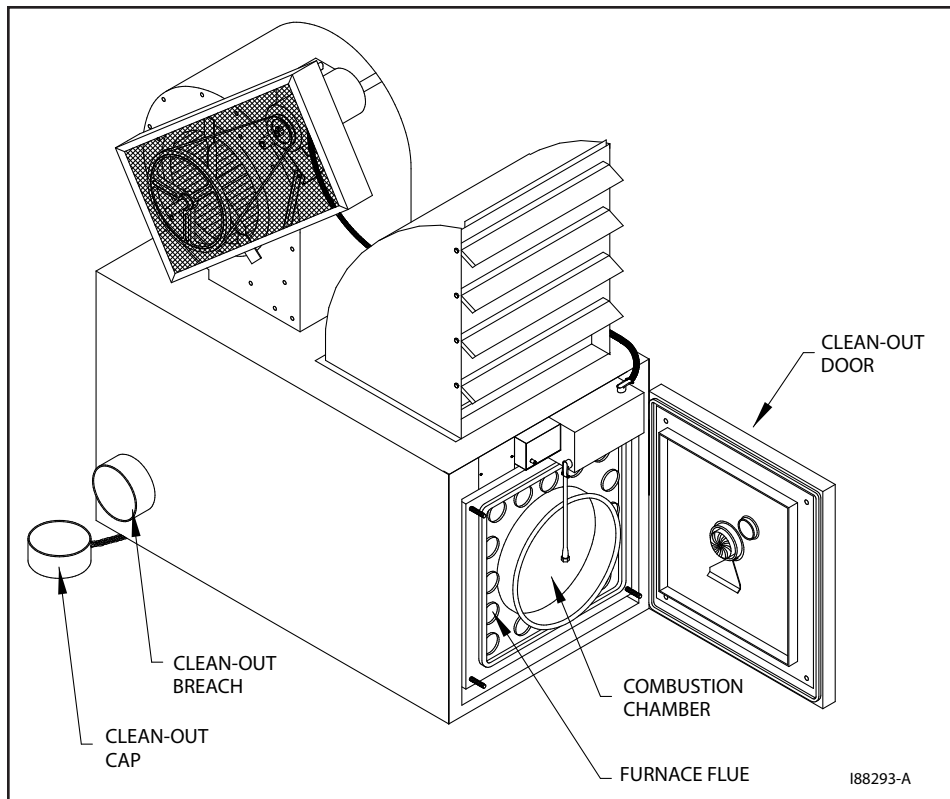

Figure 2A - Accessing the Combustion Chamber

Warranty Registration

For proper warranty registration, Clean Burn requires that you fill out the provided warranty registration card and return it *within 30 days* to:

CLEAN BURN WARRANTY REGISTRATION
Clean Burn, LLC.
4109 Capital Circle
Janesville, WI 53546

SECTION 3: FURNACE ASSEMBLY

Understanding Assembly

Assembling your Clean Burn Furnace is a six-step process which includes:

- (1) Installing the Blower Components
- (2) Installing the Hot Air Discharge Components
- (3) Installing the Energy Retention Disc
- (4) Installing the Burner
- (5) Installing the Connector Block, Oil Line Tubing, and Air Line Tubing
- (6) Installing the Mounting and Stabilizer Brackets

Clean Burn recommends that you review all assembly procedures before proceeding, paying careful attention to safety information statements. Please note that some assembly procedures apply only to certain furnace models. **Figures 3A and 3B** on the following pages provide a general overview of the furnace components and their proper assembly and how the unit should look following proper assembly.

Required Tools and Materials

The following tools and materials are required for furnace assembly and should be gathered before starting any procedures:

- Variable-speed drill
- 1/4" hex-nut driver attachment for drill
- 5/16" hex-nut driver attachment for drill
- Set of open-end wrenches (3/8" - 5/8")
- Medium adjustable wrench
- Medium straight-blade screwdriver

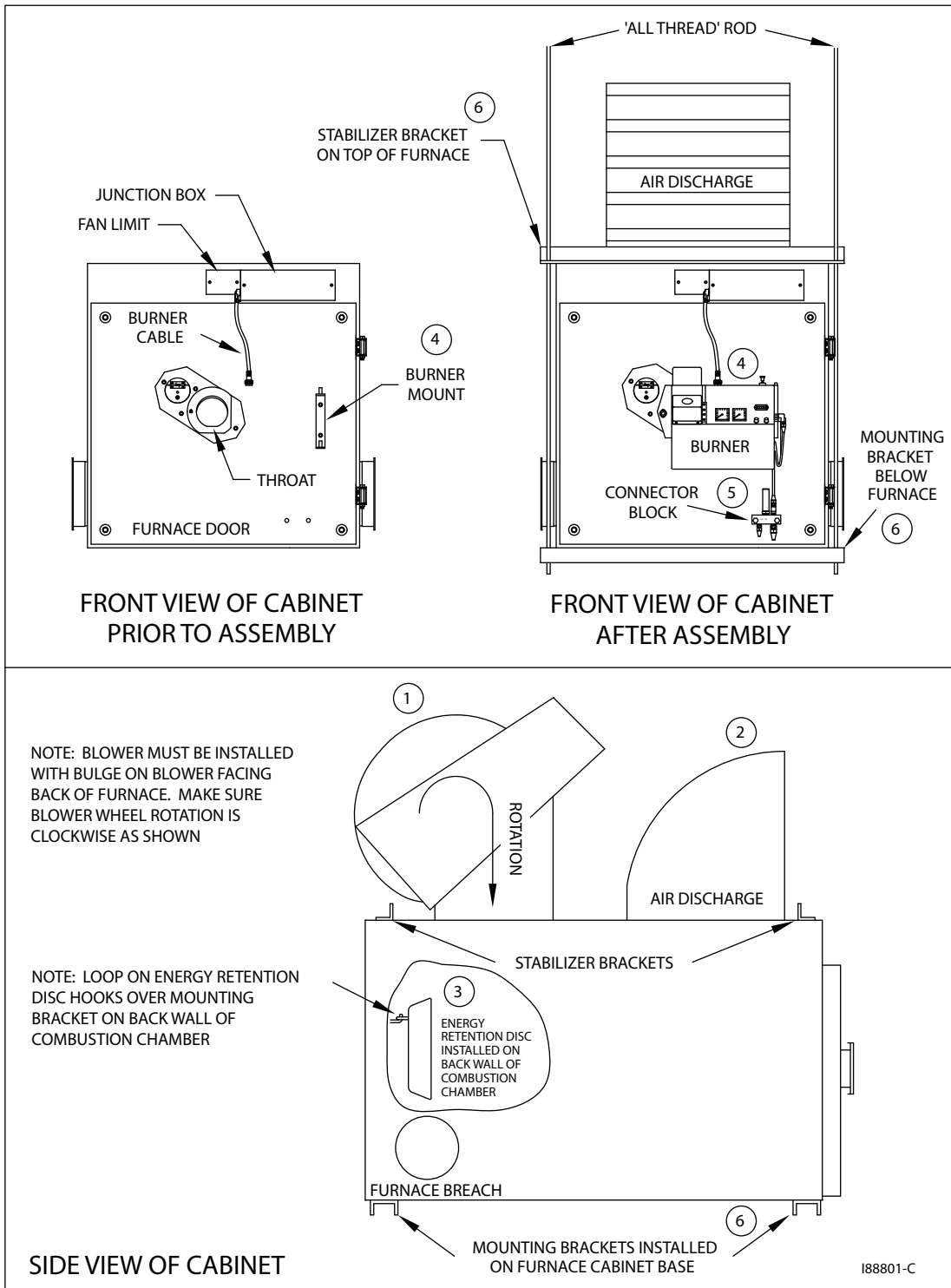

Figure 3A - Overview of Furnace Assembly

Complete assembly of the CB-3500/CB-5000 furnace according to the following list of activities as illustrated above:

- (1) Installing the Blower Assembly
- (2) Installing the Hot Air Discharge Components
- (3) Installing the Energy Retention Disc
- (4) Installing the Burner
- (5) Installing the Connector Block, Oil Line Tubing, and Air Line Tubing
- (6) Installing the Mounting and Stabilizer Brackets

NOTE: Corresponding procedures provided in order in this section.

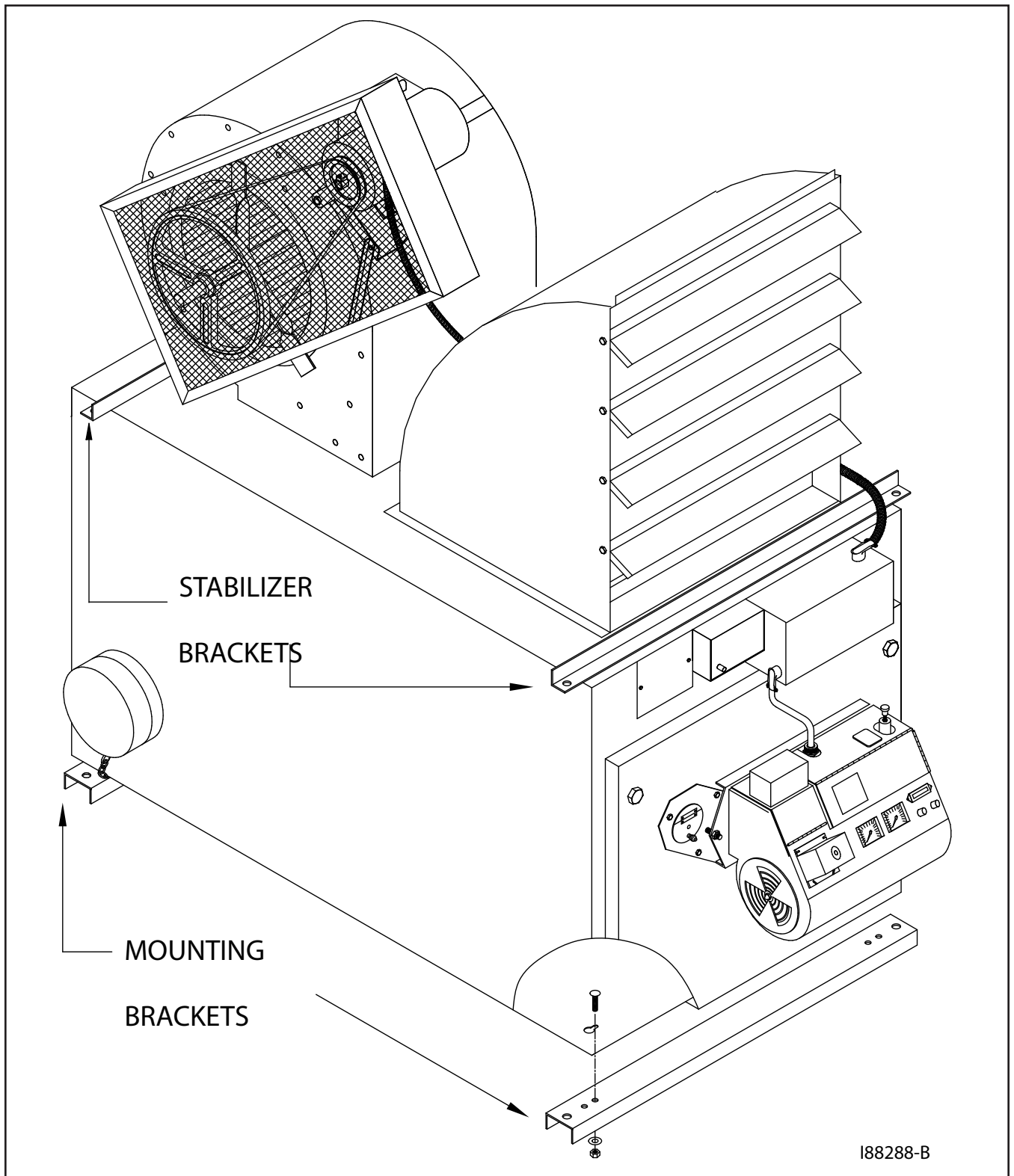

Figure 3B - Three-dimensional View - Furnace Completely Assembled with Louver Assembly for Unit Heater Application

NOTE: This figure shows the mounting/stabilizer brackets in place for a ceiling mounting installation. If your furnace will be floor or platform mounted, the brackets are not needed.

Installing the Blower Components

NOTE: The blower is installed in final position on the CB-3500 cabinet. The blower for the CB-5000 requires additional installation as described in the following procedure.

Installing the Blower (Model CB-5000 ONLY)

NOTE: For proper air flow through the furnace, the blower must be positioned so the bulge on the blower faces toward the rear of the furnace as illustrated in Figures 3A, 3B, and 3D.

1. Remove the hex-head screws, which hold the blower in the shipping position.
2. Carefully slide the blower rearward on the cabinet into position against the blower inlet lip.
3. Use self-tapping screws to install the angle support at the back of the blower to complete the blower inlet lip.
4. Install at least three (3) self-tapping screws to each side of the blower inlet to safely support the blower.

Installing the Motor on the Blower

1. Refer to Figures 3C and 3D.
2. Use self-tapping bolts to install the motor mounting bracket on the blower according to the dimensions provided in Figure 3C.
3. Slide the two (2) square-head bolts upside-down in the channel of the motor mounting bracket.
4. Install the motor mounting plate on the mounting bracket using the two bolts in the channel to hold the plate in position. **DO NOT** install the nuts on the bolts yet. Make sure the plate is flush with the side of the blower.
5. Use a self-tapping bolt to install the motor tensioning bracket on the blower according to the dimensions provided in Figure 3C.
6. Lift up on the end of the motor mounting plate until the hole in the side of the plate is aligned with the slot in the motor tensioning bracket. Push a bolt through the slot and install a nut loosely just to hold the plate in position. **DO NOT** tighten the nut yet.
7. Lift the motor into position on the motor mounting plate using the two bolts in the channel to hold the motor in place. Now loosely install the nuts on the two (2) bolts.
8. Slide the motor into position so the face of the motor is flush with the side of the blower. Now tighten the nuts.
9. Install the additional two (2) bolts and nuts through the lower holes in the motor mounting plate and motor. Tighten the nuts to hold the motor firmly in position.

Wiring the Blower Motor



WARNING: To avoid electrical shock, make sure the main power to the furnace is turned OFF before wiring the blower motor.

1. Refer to the Furnace Wiring Diagram provided in Appendix B at the back of this manual.
2. Install the electrical cable between the electrical junction box on the front of the furnace and the electrical access on the blower motor.
3. Connect the wires in the junction box according to the Furnace Wiring Diagram (Appendix B).

NOTE: *The blower motor is rated for 208-230 volts, single phase. Make sure the proper electrical circuit to the furnace has been provided by a qualified electrician as shown in the Furnace Wiring Diagram.*

BLOWER ASSEMBLY PARTS LIST

- 1 NUT
- 2 NUT
- 3 2 HP MOTOR
- 4 MOTOR PULLEY
- 5 MOTOR MOUNTING PLATE
- 6 BOLT
- 7 MOTOR TENSIONING BRACKET
- 8 BLOWER PULLEY
- 9 SELF-TAPPING BOLT
- 10 V-BELT
- 11 MOTOR MOUNTING BRACKET
- 12 SQUARE HEAD BOLT
- 13 MOTOR BUSHING (7/8" HUB)
- 14 BLOWER BUSHING (1" HUB)
- 15 LOCKWASHER
- 16 CAPSCREWS

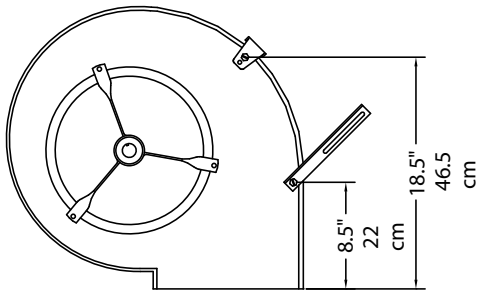
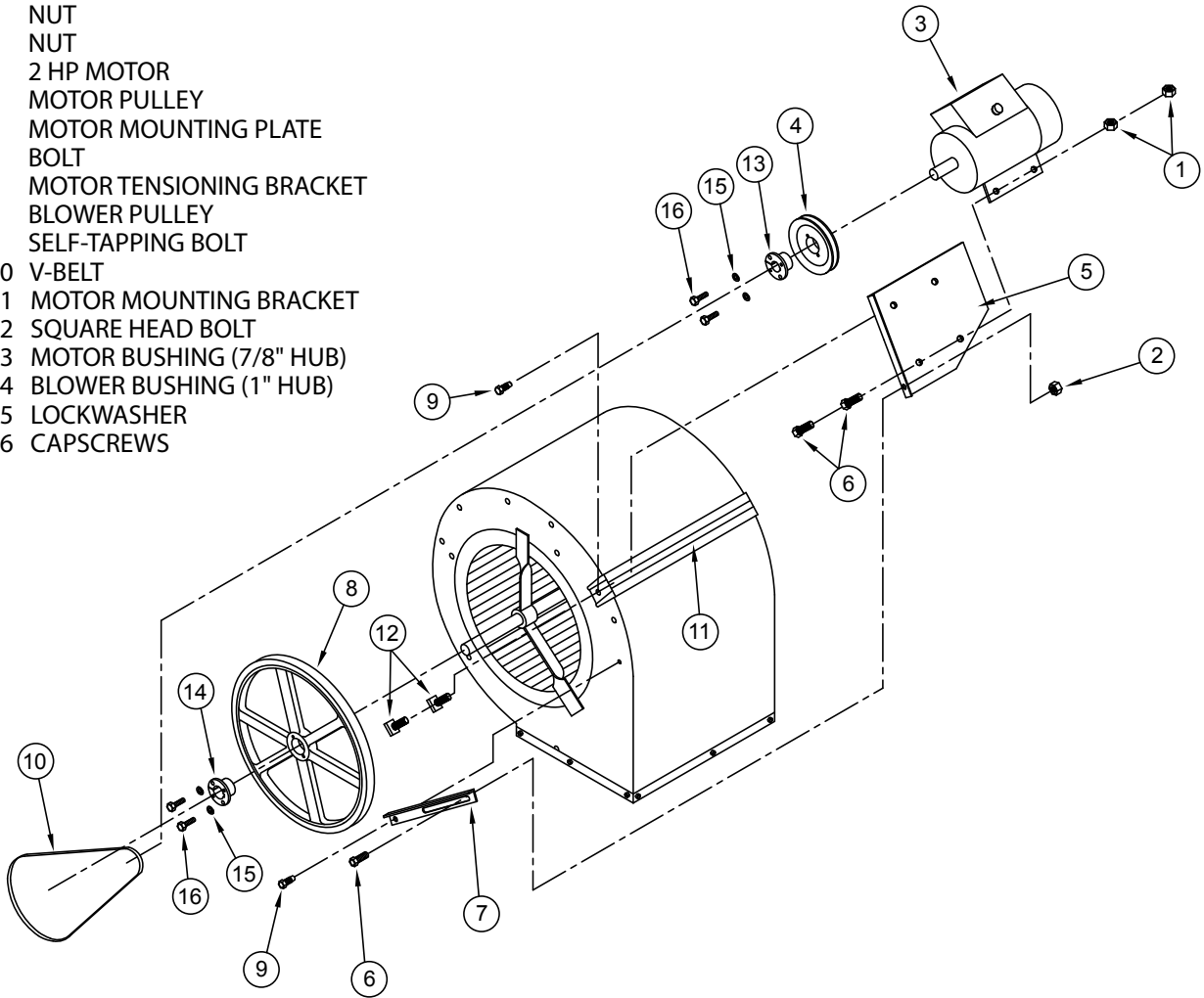

CB-3500 BLOWER

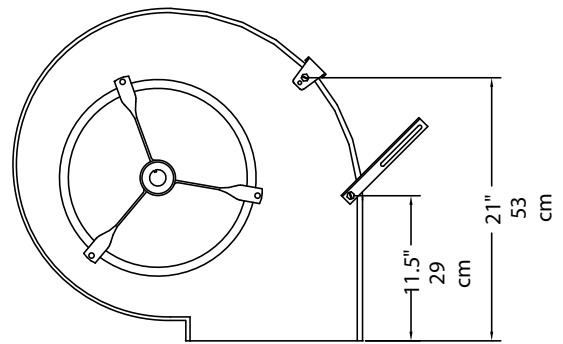

CB-5000 BLOWER

DETAIL OF BRACKET INSTALLATION

NOTE: The brackets must be installed at the correct position on the side of the blower as shown here. Note the measurements provided which should aid your positioning of the brackets.

188876-A

Figure 3C - Expanded View of Blower Assembly

Installing the Blower Components (continued)

Installing the Motor Pulley, Blower Pulley, and V-Belt

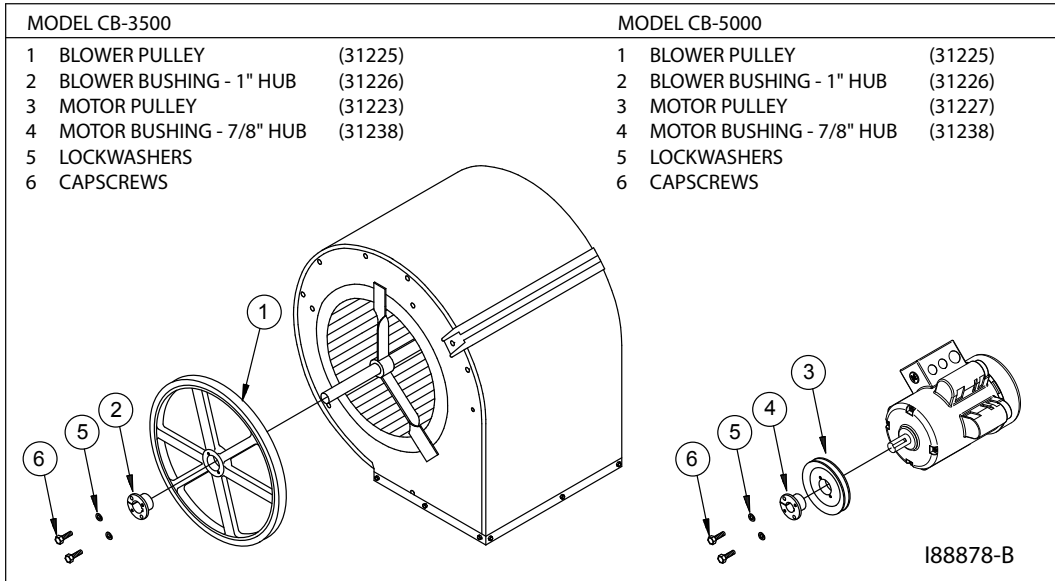

Figure 3D - Blower Pulley and Motor Pulley Parts List

1. Review the contents of the Blower Pulley and Motor Pulley as shown in Figure 3D.
2. Refer to Figure 3D. Place the blower pulley over and onto the blower shaft as far as possible with large bore end of taper outward.
3. Insert the blower key into the bushing. (If the key is deformed and does not fit into place, file the key to the proper size or replace it with a new key).
4. Slide the bushing (with key inserted) onto the shaft so the tapered end will engage into the pulley.

NOTE: If bushing does not slide freely on shaft, wedge a screwdriver blade into the saw cut at the flange OD to open the bore of the bushing. **CAUTION:** Excessive wedging will split the bushing.

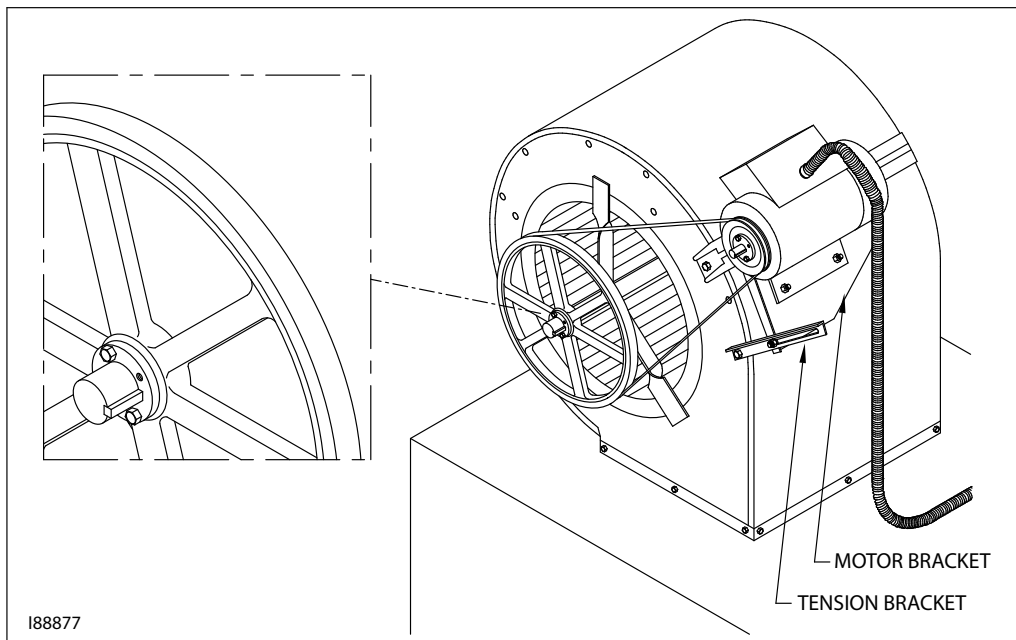

Figure 3E - Blower Assembly Installed on Furnace Cabinet

Installing the Motor Pulley, Blower Pulley, and V-Belt (continued)

5. Align drilled holes in bushing flange with tapped holes in the pulley. Use the capscrews and washers provided with the bushing package to fasten the pulley on to the bushing. **DO NOT COMPLETELY TIGHTEN THE SCREWS AT THIS POINT!** Make sure you can still slide the bushing and pulley for future alignment with the motor pulley. (Additional information is available in the “Bushing Instruction Sheet” provided with each bushing)
6. Install the motor pulley following steps 1 through 5.
7. Align the motor pulley with the blower pulley.
 - a. Place the blower bushing $\frac{1}{2}$ inch from the end of the shaft and tighten the capscrews securely (9 Ft. - Lbs. if using a torque wrench).
 - b. Place a level or straight edge flat onto the two most outer edges of the blower pulley.
 - c. Place the motor pulley and bushing about $\frac{1}{4}$ inch away from the straight edge.
 - d. Start tightening the screws on the motor bushing. As the screws are tightened, the motor pulley will approach the straight edge. **TIGHTEN THE CAPSCREWS SECURELY** (9 Ft. - Lbs. if using a torque wrench).
 - e. Four points of the two pulleys should be touching the straight edge. If they don't make full contact, loosen the screws on the motor bushing and realign it so both pulleys are on the same plane.
8. Place the belt on the pulleys, starting with the motor pulley and feeding it onto the blower pulley.
9. Tighten the belt (Refer to Figure 3E).
 - a. Raise the motor bracket and at the same time tighten the nut on the tension bracket.
 - b. **DO NOT** over tighten the belt. Leave about 1inch of slack (when pushing on the top of the belt, it should deflect about 1 inch).

Installing the Belt Guard and the Blower Guard

WARNING: To prevent serious personal injury, **DO NOT** operate the furnace without the belt and blower guards in place.

1. Refer to Figure 3F.
2. Install the belt guard and blower guard as shown.

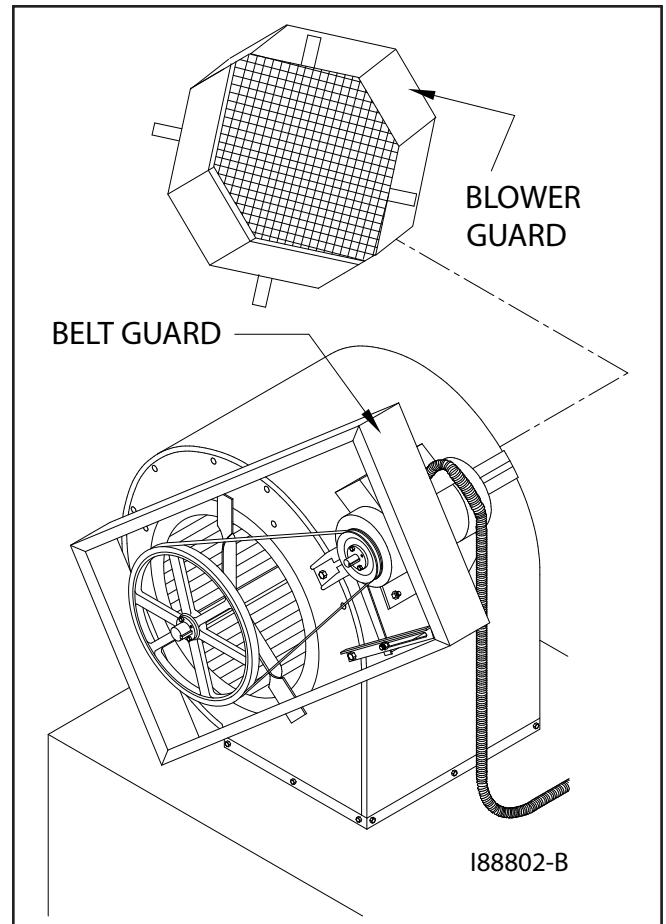

Figure 3F - Installing the Belt and Blower Guards

Installing the Hot Air Discharge Components

Determining the Air Discharge Configuration

The CB-3500 and CB-5000 furnaces may be configured for use as EITHER a Unit Heater or a Central Furnace as described below.

(1) Unit Heater

Furnace with blower for FREE AIR applications.

HOT AIR DISCHARGE: Louver assembly (components supplied)

NOTE: If the peak of your shop roof/ceiling is 14 feet or higher, install industrial-size ceiling fans to aid in efficient, even heat distribution. A minimum of one Clean Burn 56" Blade Industrial Ceiling Fan (C.B. part# 70003) or equivalent is recommended for each 2000 square feet of shop space.

Be sure to adhere to the specified clearances as stated in Section 4 of this manual.

(2) Central Furnace

Furnace with blower for DUCTING applications from .25 to .40 static pressure.*

HOT AIR DISCHARGE: Ductwork (Refer to the following chart for the proper air discharge/ducting specifications; installation to be accomplished by HVAC professionals ONLY.)

Be sure to adhere to the specified clearances as stated in Section 4 of this manual.

Air Flow (CFM) and Static Pressure (SP) Specifications

CB-3500

Air Discharge Louvers Mounted on Furnace	Air Discharge Louvers Mounted on Furnace (Fully Open - Ductwork Installed Over Top)*	Air Discharge Louvers Removed Ductwork Installed on Furnace
Duct Free**	0.25 Inches of W.C.**	0.40 Inches of W.C.**
4200 CFM	4000 CFM	3900 CFM

CB-5000

Air Discharge Louvers Mounted on Furnace	Air Discharge Louvers Mounted on Furnace (Fully Open - Ductwork Installed Over Top)*	Air Discharge Louvers Removed Ductwork Installed on Furnace
Duct Free**	0.25 Inches of W.C.**	0.40 Inches of W.C.**
5500 CFM	5200 CFM	5100 CFM

C77003

***ATTENTION:** A qualified electrician must check the blower motor amperage during operation of the furnace to ensure that motor amperage does not exceed 85% of the maximum amperage on the motor label. DO NOT operate the blower motor above 85% of maximum amperage or motor damage may occur.

UNIT HEATER APPLICATIONS: Installing the Air Discharge Louver Assembly

The body of the air discharge louver assembly is shipped assembled and is packed on top of the furnace cabinet. The louvers, nuts and bolts, which must be assembled separately, are packed inside the combustion chamber.

It is very important to install the air discharge to direct the flow of the hot air from the furnace as desired for your application. As you will note from Figure 3G, the air discharge may be installed facing forward (as shown) or rotated 90 degrees to the left or right. Additionally, the louvers may be installed horizontally or vertically to direct the flow of the heated air.

1. Position the body of the air discharge as desired over the hot air outlet on the furnace (i.e. facing forward, right, or left).
ATTENTION: KEEP THE ORIFICE PLATE IN PLACE (as shown in Figure 3G) when installing the louver assembly. The orifice plate is *necessary* for proper air flow from the furnace.
2. Use the 12 self-tapping screws to securely attach the body of the louver assembly to the furnace cabinet.
3. Install the louvers in the desired position (i.e. horizontally or vertically) using the bolts and locking nuts provided.
ATTENTION: DO NOT restrict the flow of hot air from the furnace by closing the louvers, or damage to the furnace and/or blower motor may occur.

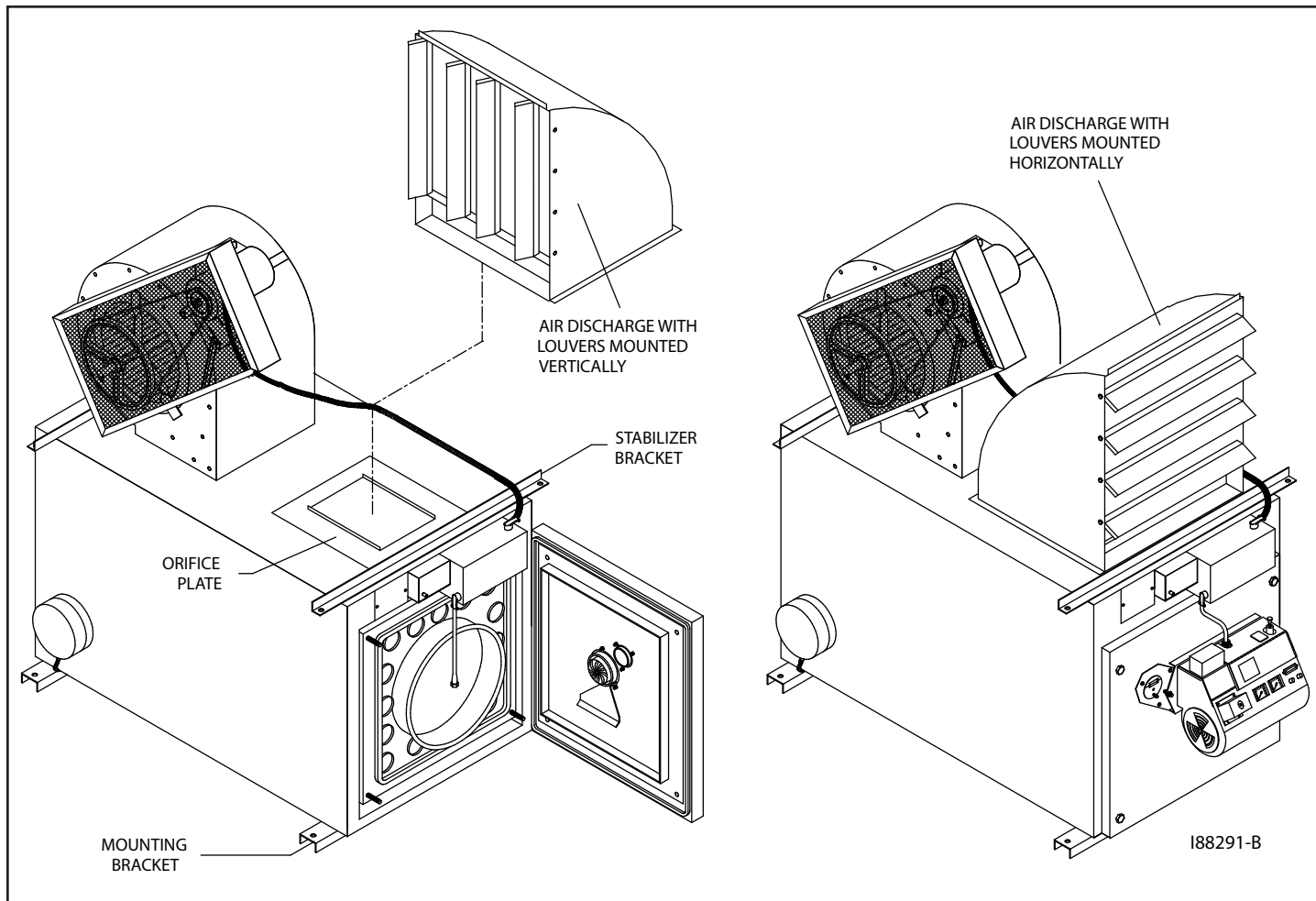

Figure 3G - Installation of the Hot Air Discharge Louver Assembly

CENTRAL FURNACE APPLICATIONS: Installing Ductwork

If you plan to install ductwork on your furnace, *it is mandatory that qualified HVAC personnel design and install the ductwork system to the CFM and SP specifications provided in this manual.* Establish correct duct size according to the following specifications and use radial bends or turning vanes to allow for proper air flow.

Sizing the Ductwork:

- **For Model CB-3500**, the outlet on the air discharge is 20" x 20". *The main duct (CB-3500) must initially maintain an outlet size of 20" x 20".*
- **For Model CB-5000**, the outlet on the air discharge is 24" x 24". *The main duct (CB-5000) must initially maintain an outlet size of 24" x 24".*

Additionally, to ensure proper air flow from the furnace and to prevent damage to related furnace components, adhere to the following guidelines for installing ductwork with your CB-3500 or CB-5000 central furnace application.

Installation Guidelines for Ductwork:

- It is essential that qualified HVAC personnel properly design the ductwork for your furnace and determine the static pressure for your ducting application;
ATTENTION: Failure to adhere to the static pressure and CFM specifications provided in this manual may result in damage to the blower motor.
- The ductwork should be installed directly over the opening in the top of the furnace cabinet (i.e. where the louver assembly would be installed for free air applications.)
- **THE ORIFICE PLATE MUST BE REMOVED for all ductwork applications.**
- *Existing ductwork* at your installation site may NOT be appropriate or meet the specifications for your furnace installation.

Installing the Energy Retention Disc

Installing the Energy Retention Disc in the Combustion Chamber

ATTENTION: DO NOT fire your furnace without the Energy Retention Disc in place, or combustion chamber damage will occur. Handle the Energy Retention Disc carefully to avoid damage.

1. Refer to Figure 3A to review the proper positioning of the Energy Retention Disc.
2. Swing open the clean-out door on the front of the furnace to gain access to the combustion chamber.
3. Use a long rod to support the Energy Retention Disc as you guide it into position on the back of the combustion chamber. The loop on the back of the Energy Retention Disc fits over the hook located on the back of the combustion chamber.

Closing the Furnace Door

1. After the Energy Retention Disc has been installed, close the furnace clean-out door.
2. Tighten the four (4) lock-down nuts in a criss-cross pattern until all are snug.

Installing the Burner

Checking the Burner Nozzle and Electrodes

NOTE: The burner nozzle is factory installed. Model CB-3500 uses a Delavan 9-5 nozzle. Model CB-5000 uses a Delavan 9-11 nozzle. The nozzle size is indicated on the nozzle head as shown in Figure 3H. Refer also to **Appendix A** at the back of the manual for additional specifications/instructions on the burner nozzle.

NOTE: Check the electrode settings as specified in Figure 3H. The electrode settings must be correct for your burner to operate properly.

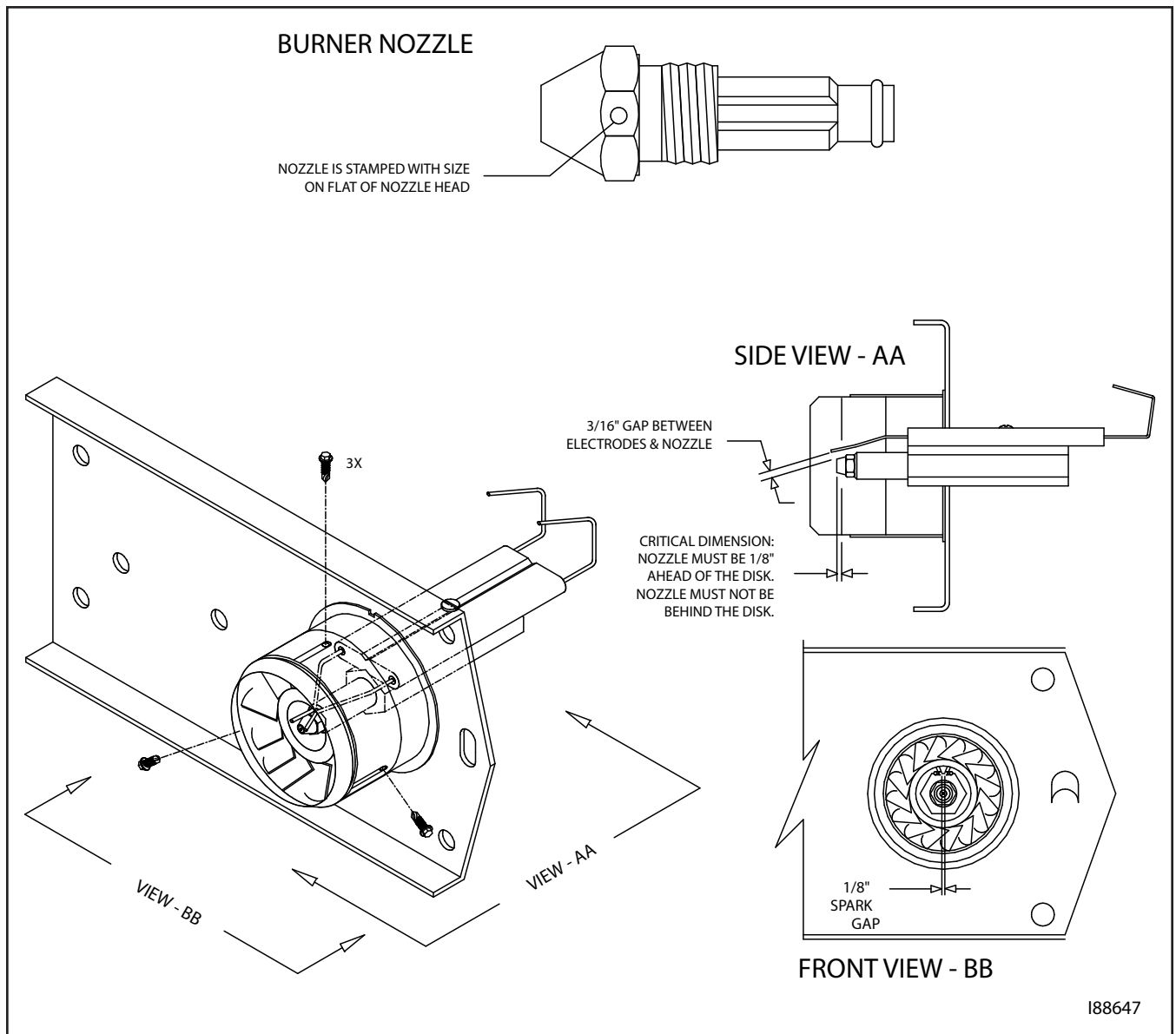

Figure 3H - Burner Nozzle and Electrode Specifications

Installing the Burner (continued)

Mounting the Burner on the Hinge Bracket

ATTENTION: Burner tube components (e.g. electrodes and retention head) are factory set. Handle the burner with extreme care so that burner components are not damaged.

1. Remove the nut from the mounting flange of the furnace cabinet, and set it aside for later use.
2. Lift the burner into position so that it is mounted on the hinge bracket on the furnace cabinet.
3. Carefully swing the burner so the retention head enters the throat of the furnace.
4. Check the clearance between the retention head and the furnace throat. *There must be at least 1/8" clearance, so the retention head is not "bumped" as you swing the burner into firing position.*

NOTE: If the retention head "bumps" the furnace throat, adjust the hinge bracket bolts as follows:

- While supporting the burner, slightly loosen the two (2) hinge bracket bolts.
- Carefully re-position the burner so it swings freely into its firing position.
- With the burner in its firing position, re-tighten the hinge bracket bolts.

Installing the Connector Block, Oil Line Tubing, and Air Line Tubing

ATTENTION: DO NOT use teflon tape on any fittings. Teflon tape will plug vital burner components and void your warranty.

Installing the Connector Block on the Furnace Door

1. Refer to Figure 3I.
2. Use the two (2) bolts to install the aluminum connector block onto the furnace door.
3. Remove and discard the red caps and plugs from the fittings and ports on the connector block. DO NOT allow any dirt/debris to enter these components during furnace assembly.

ATTENTION: The connector block includes an accumulator. The accumulator functions like a shock absorber on the oil line to prevent pressure buildup and protect vital burner components. It is important that the connector block is installed as shown so that the accumulator is in a vertical position to prevent sediment from settling in the accumulator. *Never operate your furnace without the connector block and accumulator properly installed on the furnace, or damage may occur to vital burner components.*

Installing the Oil Line Tubing

ATTENTION: DO NOT disassemble the compression fitting from the swivel fitting. To prevent leaks, the NPT threads of the compression fitting have been sealed with hydraulic sealant during assembly of the fittings at the factory.

1. Remove and discard the red caps from the oil line tubing.
2. Loosely install the oil line tubing into the oil line fitting on the burner.
3. Use a wrench to slightly rotate the oil line fitting on the burner counterclockwise so the tubing lines up with the swivel assembly. Slightly bend the tubing as shown in Figure 3I, if required, to "line up" the oil line.
4. If necessary, use a tubing cutter to cut the tubing to the proper length.

ATTENTION: Due to adjustment of the burner hinge bracket, the oil line tubing may need to be cut to fit properly. DO NOT lift up on the burner when installing the oil line tubing to compensate for oil line tubing that is too long. This will place the weight of the burner on the swivel fitting and result in leaks at the swivel fitting seal.

(procedure continued on next page)

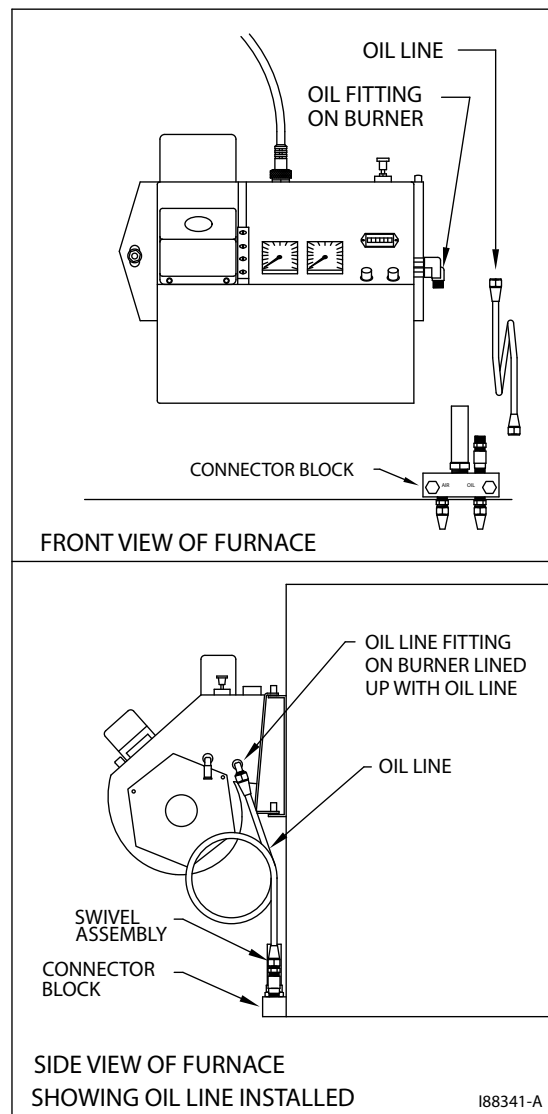

Figure 3I - Installation of Connector Block and Oil Line

Installing the Connector Block, Oil Line Tubing, and Air Line Tubing (continued)

Installing the Oil Line Tubing (continued)

5. Make sure that the curl in the oil line is positioned as shown in Figure 3I so that the burner can swing open correctly.
6. Install the oil line tubing and tighten the nuts on the compression fittings. **DO NOT** overtighten these fittings to avoid damaging the ferrules.

NOTE: You may also check the positioning of the oil line according to Figure 3J, which provides a larger front view of the connector block assembly.

Installing the Air Line Tubing

1. Remove and discard the red caps from the air line tubing.
2. Refer to Figure 3J. Push the air line tubing into the swivel fitting on the connector block until the tubing bottoms out in the fitting.
3. Repeat this procedure to connect the air line tubing to the air line fitting on the side of the burner.

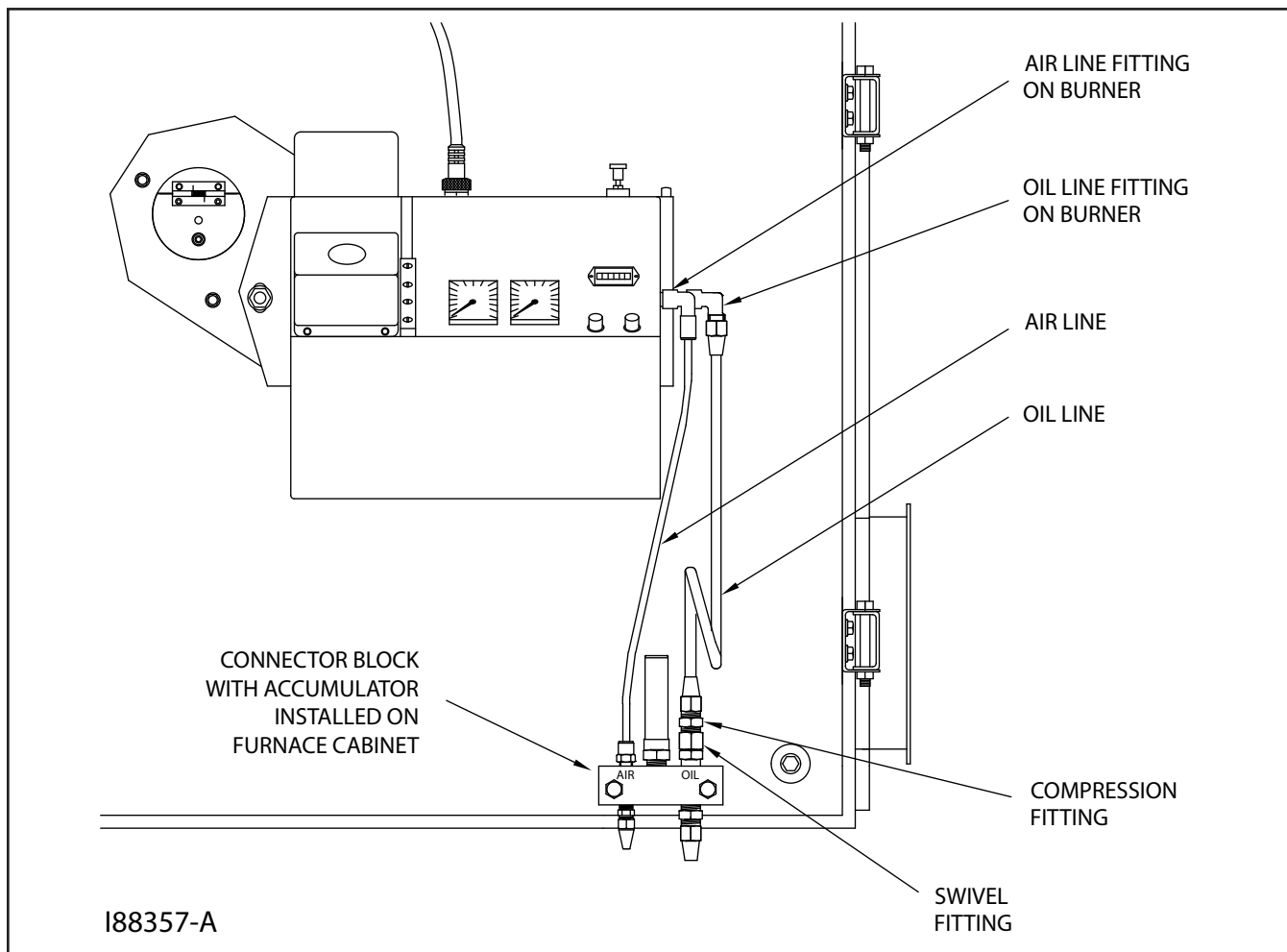

Figure 3J - Installation of Connector Block, Oil Line, and Air Line (Front View)

Locking the Burner into Firing Position

1. Swing the burner into firing position.
2. Install and tighten the lock-down nut on the mounting plate bolt to secure the burner in its firing position.
3. Plug the burner electrical cable into the receptacle on the top of the burner housing.
4. Tighten the locking ring to secure the electrical cable.

NOTE: Be sure to properly align the plug when plugging it into the receptacle. See Fig 3K.

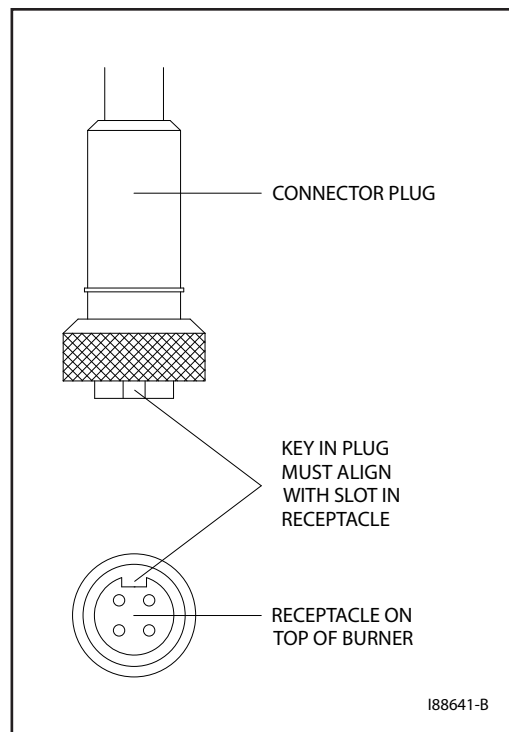

Figure 3K - Detail of Burner Electric Receptacle

Installing the Mounting and Stabilizer Brackets

Installing the Brackets on the Furnace Cabinet (For Ceiling Mounting Only)

NOTE: If you are **ceiling mounting** your furnace, it is critical that the mounting and stabilizer brackets be installed as described below.

The **mounting brackets** must be attached to the furnace base to allow ceiling installation of the furnace using "all-thread" rods. See **Figures 3A/3B**.

The weight of the furnace must be supported by the mounting brackets. The stabilizer brackets are installed on the top of the furnace to properly align the "all-thread" rods. The stabilizer brackets will not support the furnace.

1. Refer to Figures 3A and 3B.
2. Install both mounting brackets (1" channel) on the base of the furnace using the four (4) bolts supplied.
3. Install the two (2) stabilizer brackets on the top of the furnace using self-tapping screws.

NOTE: Your furnace is now assembled and ready for installation. Install the furnace as soon as possible so the burner and/or blower are not "bumped" or damaged. If you must store the furnace for a period of time before installation, make sure it is located in a safe, secure area.

SECTION 4: FURNACE INSTALLATION

Understanding Installation

Installing your Clean Burn furnace is a multi-step process which includes:

- (1) Selecting a Location
- (2) Mounting the Furnace
- (3) Oil Tank Installation Specifications (review)
- (4) Installing the Metering Pump
- (5) Wiring the Furnace and Pump
- (6) Installing the Oil Lines
- (7) Installing the Compressed Air Line
- (8) Installing the Stack
- (9) Installing the Wall Thermostat
- (10) Inspecting the Installation

Clean Burn recommends that you review all procedures before beginning installation, paying careful attention to safety information statements. **Figure 4A** provides a general overview of a typical furnace installation and should be reviewed closely before proceeding.



WARNING: The installation, operation, and maintenance of this equipment in the U.S. must be accomplished by qualified personnel and in compliance with the specifications in the Clean Burn Operator's Manual and with all national, state, and local codes or authorities having jurisdiction over environmental control, building inspection and fuel, fire and electrical safety and the following standards:

NFPA 30	Flammable and Combustible Liquids Code
NFPA 30A	Automotive and Marine Service Station Code
NFPA 31	Standard for the Installation of Oil Burning Equipment
NFPA 211	Chimneys, Fireplaces, Vents and Solid Fuel Burning Appliances
NFPA88A	Parking Structures
NFPA 88B	Repair Garages
NFPA 70	National Electrical Code
The International Mechanical Code	
The International Building Code	
The International Fire Code	
The International Fuel Gas Code	

Likewise, the installation, operation, and maintenance of this equipment **in Canada** is to be accomplished by qualified personnel and in compliance with the specifications in the Clean Burn Operator's Manual and in accordance with the regulation of authorities having jurisdiction and the following CSA Standards: B139 - Installation Code for Oil Burning Equipment; B140.0 - General Requirements for Oil Burning Equipment; and C22.1 - Canadian Electrical Code, Part 1.

Failure to comply with these standards and requirements may result in equipment damage, fire, explosion, personal injury and/or death.



WARNING: Improper installation can adversely affect the proper, safe operation of your furnace. It is critical that your furnace installer reads and follows the instructions provided in this manual.



WARNING: When installing your furnace, adhere to the minimum clearances from combustible surfaces as stated in Section 4. These clearances also provide adequate space for servicing. Failure to maintain proper clearances may result in fire, explosion, personal injury, or death.

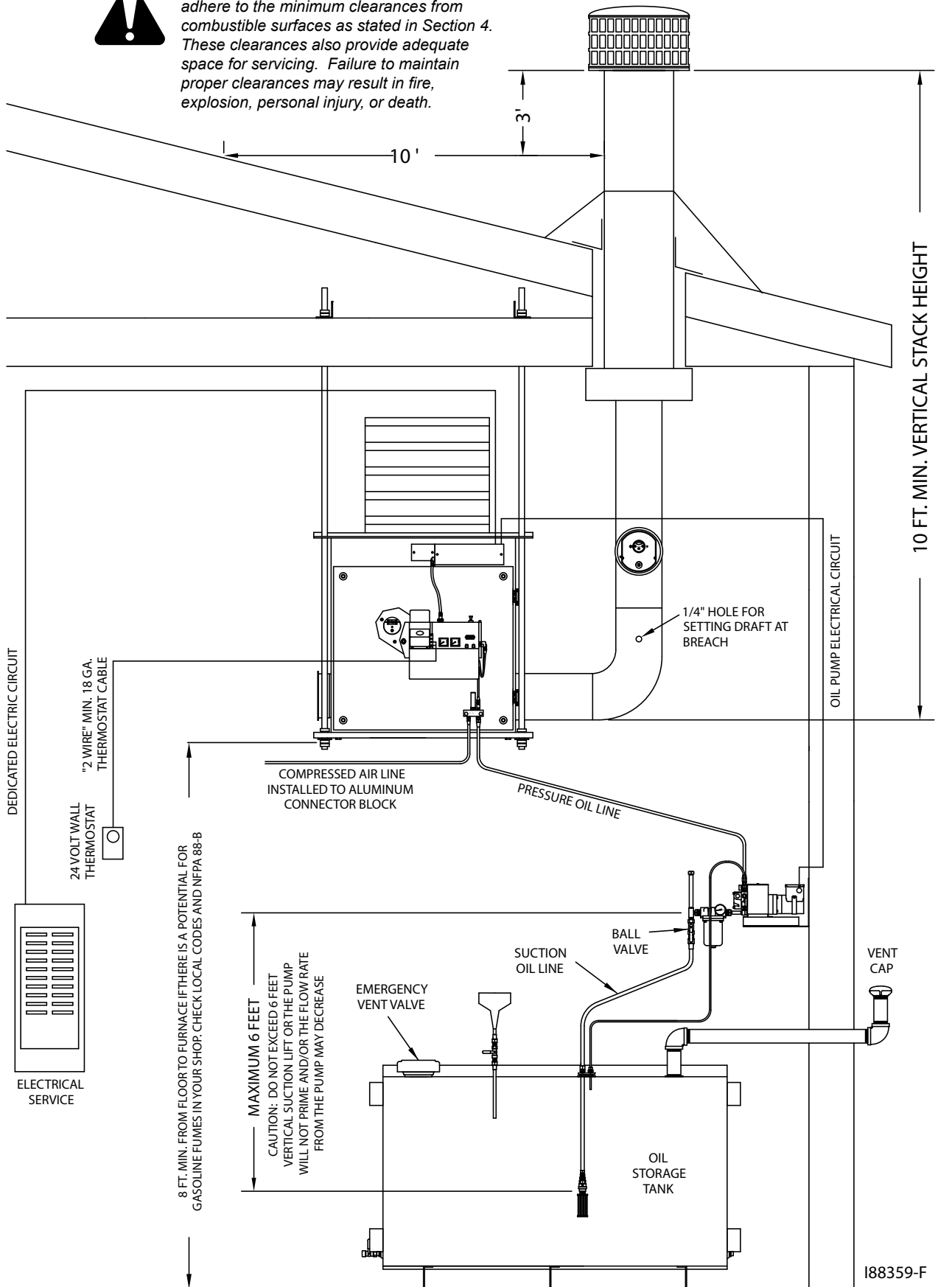

188359-F

Figure 4A - Typical CB-3500/5000 Furnace Installation

Selecting a Location

Guidelines for Selecting a Location

The location you select for your furnace must allow the following:

- Unobstructed, even heat distribution.
- Safe, easy access for servicing.
- Unobstructed passage for shop vehicles and equipment.
- Proper clearances from combustibles. *Verify according to your local safety codes.*
- Adequate combustion air per local codes.
- Proper stack installation.



WARNING: Adhere to the following *minimum* clearances from combustible surfaces and to provide adequate clearance for servicing (also refer to **Figure 4B** for visual reference); failure to maintain proper clearances may result in fire, explosion, personal injury or death.

CLEARANCES FOR CB-3500/CB-5000 INSTALLATIONS

- TOP (above blower)..... 2"
- FRONT (burner)..... 60"
- SIDES 24"
- CHIMNEY CONNECTOR 18"
- REAR 18"
- BOTTOM..... 24"
- WARM AIR DUCTS within 3ft.** 6"

**Where applicable



WARNING: National codes require that your furnace is mounted a minimum of eight (8) feet off the ground when installing the furnace in a repair facility. Refer to NFPA-88B, *Standard for Repair Garages*, Chapter 3, *Hazards*, Sec. 3-2.3.1.

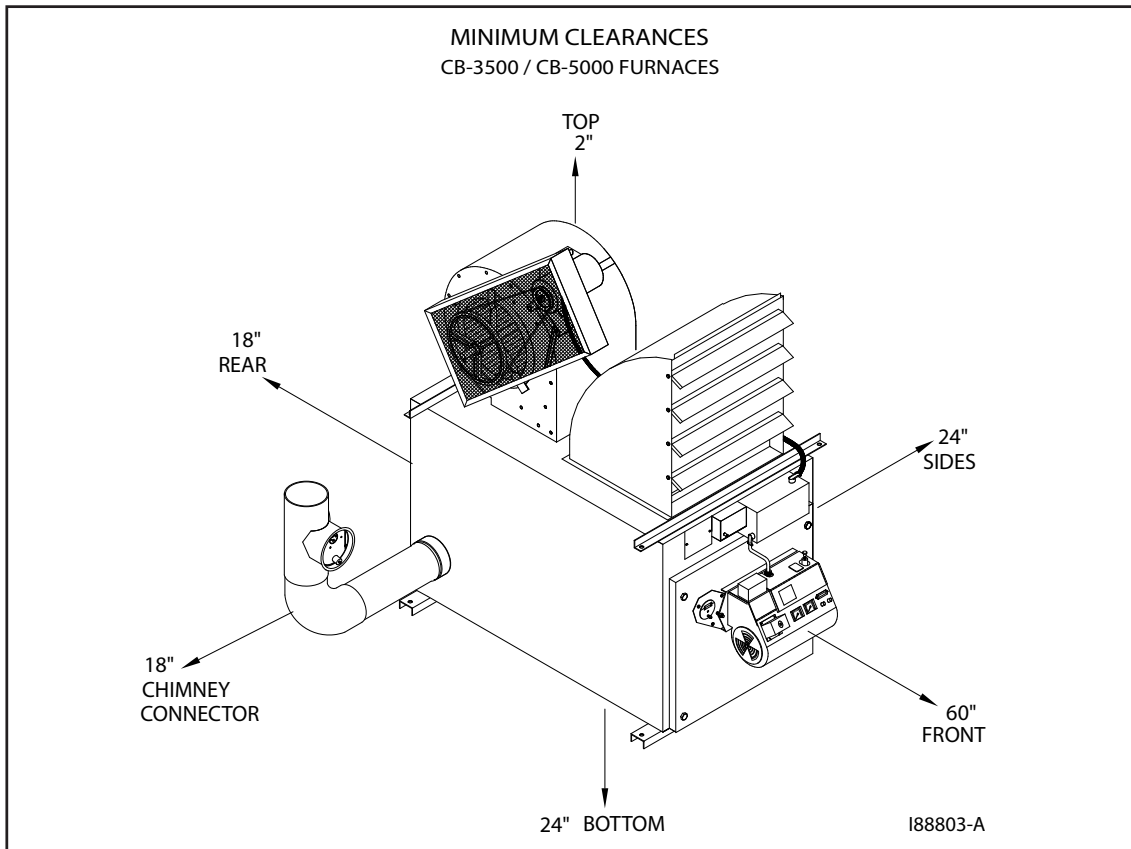

Figure 4B - Clearances from Combustibles

Mounting the Furnace

After selecting a safe and appropriate location for your furnace, construct the mounting system as required by the location and the following specifications.

Ceiling Mounting

WARNING: To prevent serious personal injury, ensure that your furnace mounting system can safely bear the suspended weight of the furnace and allow safe servicing of furnace components. Use adequately sized square tubing or angle iron bridged across sufficient structural members to safely support the furnace.

1. Refer to Figure 4C.
2. Follow the instructions as provided in the diagram.
3. Use a spirit level to make sure the cabinet is level side to side and front to back.

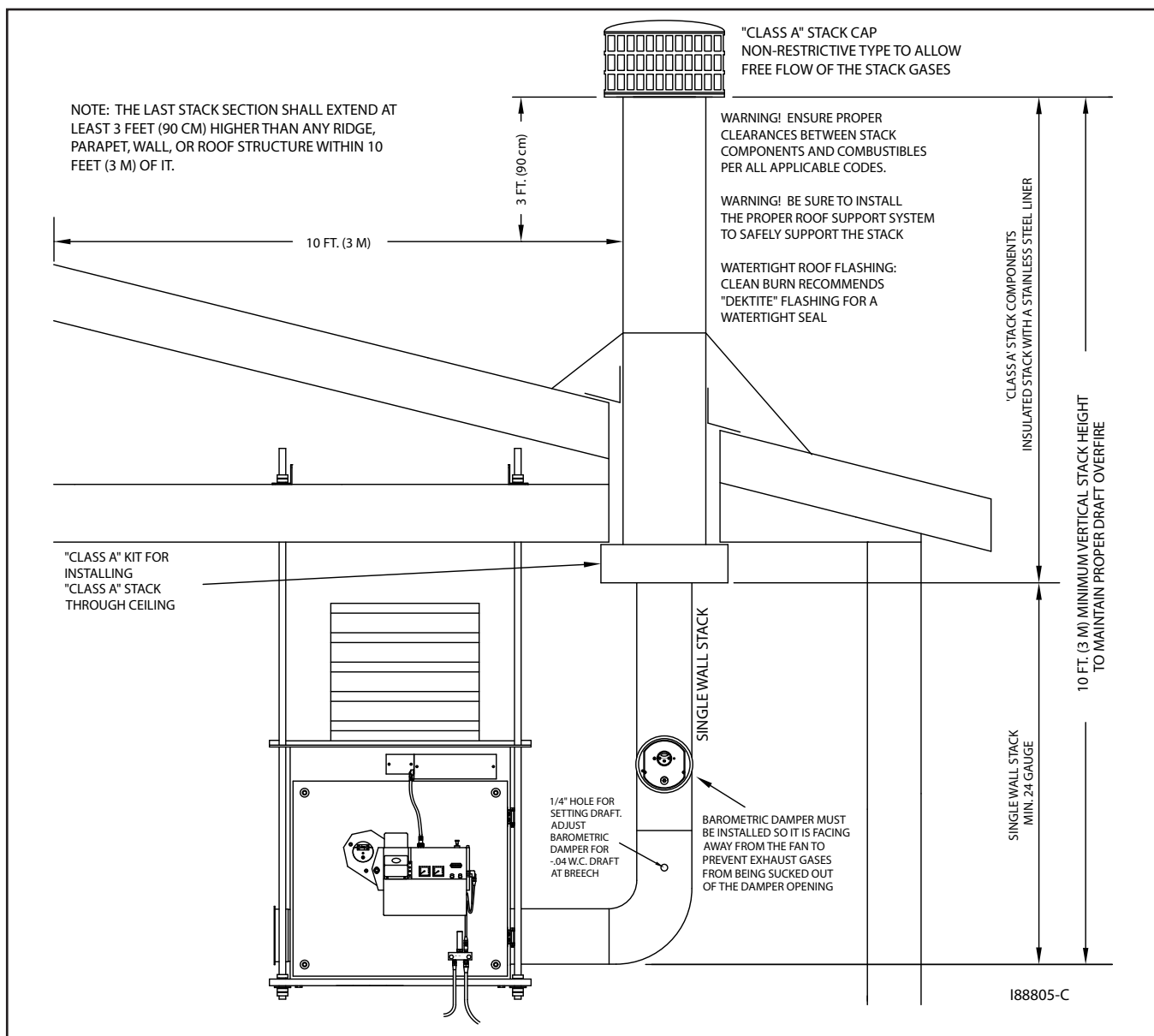

Figure 4C - Ceiling Mounting Installation Overview

Mounting the Furnace (continued)

Raised Platform Mounting

WARNING: To prevent serious personal injury, make sure the platform is designed to safely bear the weight of the furnace and allow safe servicing of furnace components. The platform must be constructed of non-combustible materials (e.g. steel) and must be securely anchored to an adjacent wall.

1. Refer to Figure 4D, and follow the instructions as provided in the diagram.

Floor Mounting

WARNING: To prevent serious personal injury, make sure the floor can safely bear the weight of the furnace.

CAUTION: If you are installing your furnace in an area with a combustible floor (e.g. over the top of a parts room or on a mezzanine), you must construct a *non-combustible* floor as shown in Figure 4E. Refer to NFPA-31 or CSA-B-139.

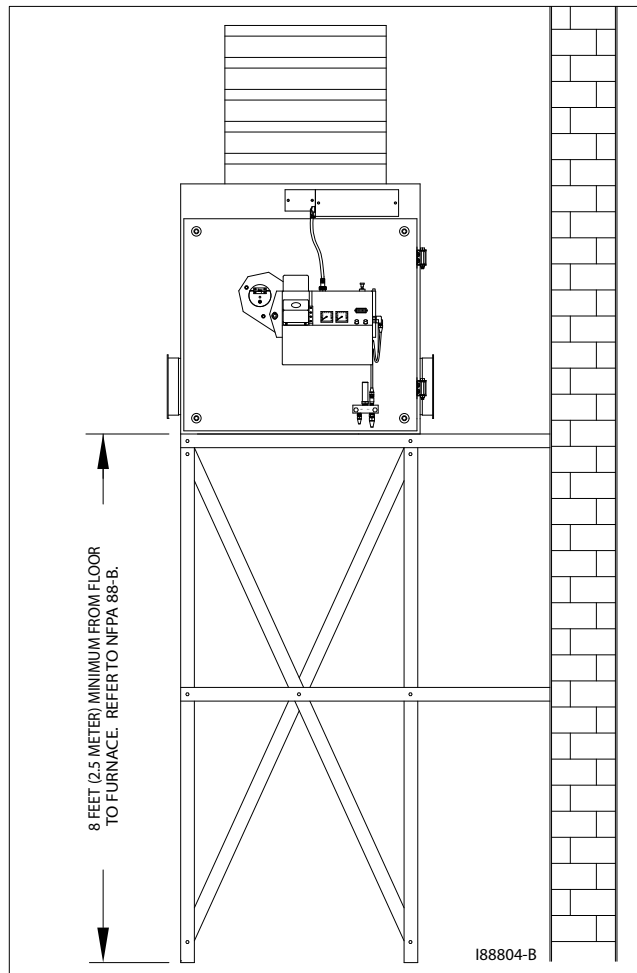

Figure 4D - Furnace Installed on Raised Platform

Constructing A Non-Combustible Floor

1. Determine the size of floor you will need to construct:
 - Measure the width and length of the cabinet of the furnace.
 - Add 12" (minimum) to *all* sides of the cabinet to achieve the total measurement for the non-combustible floor.

EXAMPLE: The CB-3500 measures 58" long x 35" wide.

$$58" + 12" + 12" = 82" \text{ long}$$

$$35" + 12" + 12" = 59" \text{ wide}$$
2. Refer to Figure 4E. Install two (2) pieces of 5/8" sheet rock on top of the combustible material (wooden floor, wooden beams, etc.) The sheet rock must be cut to the size of the total non-combustible floor area.
3. Place a sheet of 24-gauge (minimum) galvanized sheet metal on top of the 5/8" sheet rock; the sheet metal must cover the sheet rock completely.
4. Place 4" thick (minimum) hollow masonry block, end to end, on top of the 24-gauge sheet metal to make a solid foundation. Be sure to add center cross blocking to safely and adequately support the furnace.

Constructing A Non-Combustible Floor (continued)

5. Place a 24-gauge sheet metal pan with a 1" containment lip on top of the masonry blocks. This will provide containment of any oil that may be spilled while working on the furnace.
6. Position the furnace on top of the sheet metal pan; make sure you maintain the extra 12" minimum clearance on all sides of the cabinet.
7. Ensure that the installation adheres to all clearances from combustibles as stated at the beginning of Section 4 in this manual.
8. After positioning the furnace cabinet on the sheet metal pan, install 2" tall (minimum) cinder blocks (4) under each corner of the furnace to elevate the cabinet off the sheet metal pan to allow clearance for installation of fittings on the connector block.

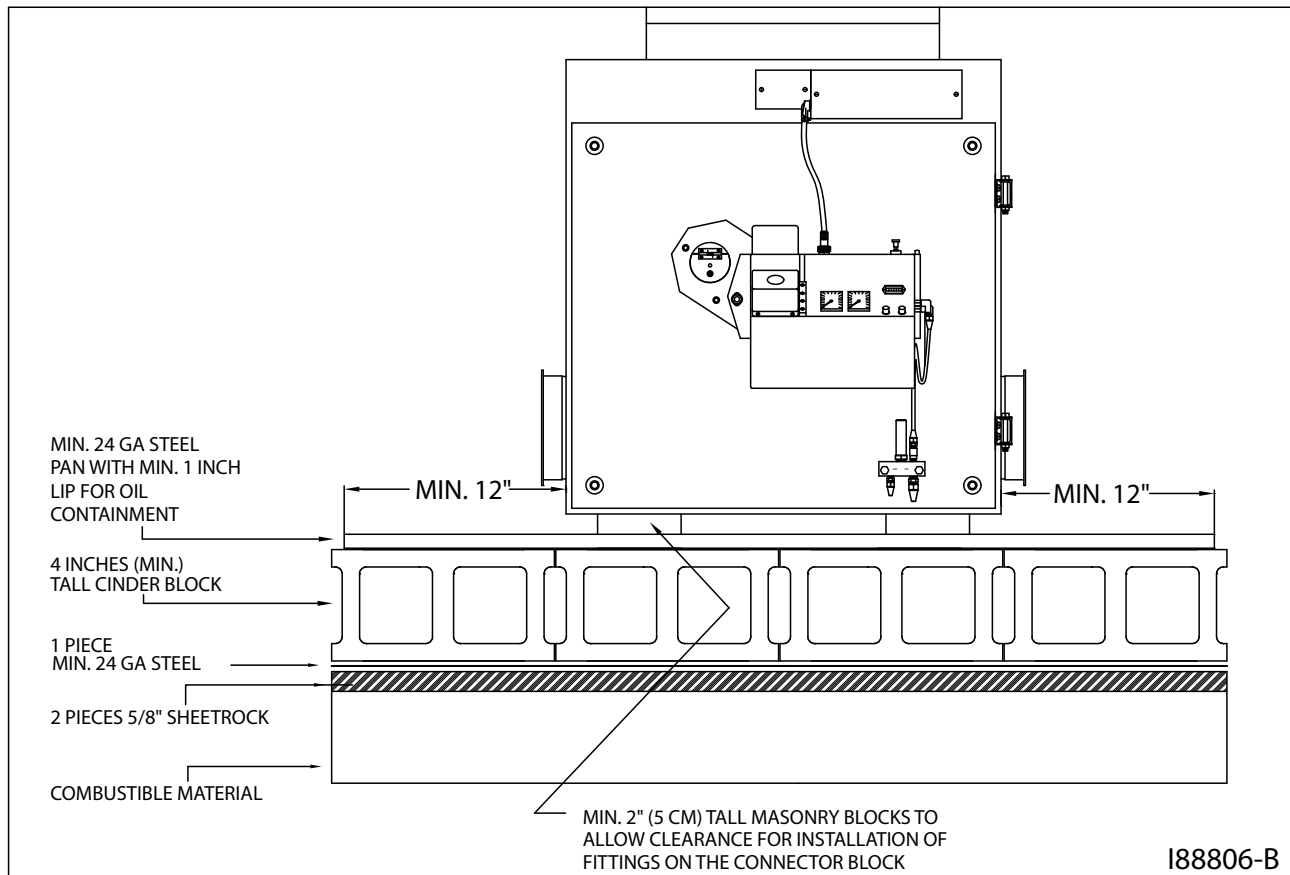

Figure 4E - Furnace Installed on Non-Combustible Floor



Oil Tank Installation Specifications

Ensure that your tank installation adheres to the following safety guidelines as stated here and in **Section 1** of this manual.

The tank safety label (shown at right) also summarizes these important specifications for tank installation and usage. If you do not have a copy of this label, please contact your Clean Burn dealer for a copy, which is to be affixed directly to your used oil supply tank.

- **The tank installation must meet all national and local codes.** Consult your local municipal authorities for more information as necessary.
- The tank must be listed to UL 80, UL 142, or equivalent standard.
- Use a **minimum 215-gallon** tank. DO NOT use a 55-gallon drum as a substitute for an appropriate tank. The tank must be large enough to allow water, sludge, etc. to settle out of the used oil.
- Single wall tanks should have a **manual shut-off type valve** on the side of the tank to allow the water, sludge, etc. to be drained from the bottom of the tank.
- All **unused openings in the tank must be plugged** or capped off.
- For optimal system functioning, Clean Burn recommends **inside tank installations** as shown in Figures 4A, 4F, and 4J.
- Some codes require the tank to be **vented to the outside** of the building using iron or steel pipe and fittings with an approved vent cap.
- Carefully review the oil tank and pump installation details as shown in Figures 4A, 4F and 4J. Pertinent information is also supplied with the metering pump and oil line installation procedures (following in Section 4).
- Ensure that the oil supply tank is **properly maintained**; refer to Section 9 in this manual for related procedures.

ATTENTION: For outside tank installations and/or tanks larger than 500 gallons, contact your local Clean Burn Distributor for installation recommendations and specifications.

⚠ WARNING	
	
Fire and explosion hazards To prevent serious injury or death:	
<p>ONLY place these listed substances in this used-oil supply tank:</p> <ul style="list-style-type: none"> • Used crankcase oil • Used automatic transmission fluid • Used hydraulic oil • #2 fuel oil <p>Do NOT place flammable or corrosive substances such as gasoline, chlorinated oils, solvents, paint thinners, or any other unsafe substances in this used-oil supply tank.</p>	
<p>Do NOT weld or allow open flame within 35 feet of this used-oil supply tank.</p>	
<p>Tank installation MUST comply with NFPA 30 and 31 Fire Codes, including the following requirements:</p> <ul style="list-style-type: none"> • Tank must be listed to UL 80 or UL 142. • Tank must be vented to outside. • Emergency vent or explosion relief must be installed on tank. • Inside fill allowed only with funnel including 1/4 turn-to-close fall valve, which must be closed after filling. • All other openings must be plugged • All oil lines must be constructed of copper, steel, or brass components. Do NOT use rubber or plastic tubing or piping, or any other inappropriate material. 	
	<p>Follow all instructions for tank installation in Operator's Manual.</p>

42366 Rev. 2

Oil Tank Installation Specifications (continued)

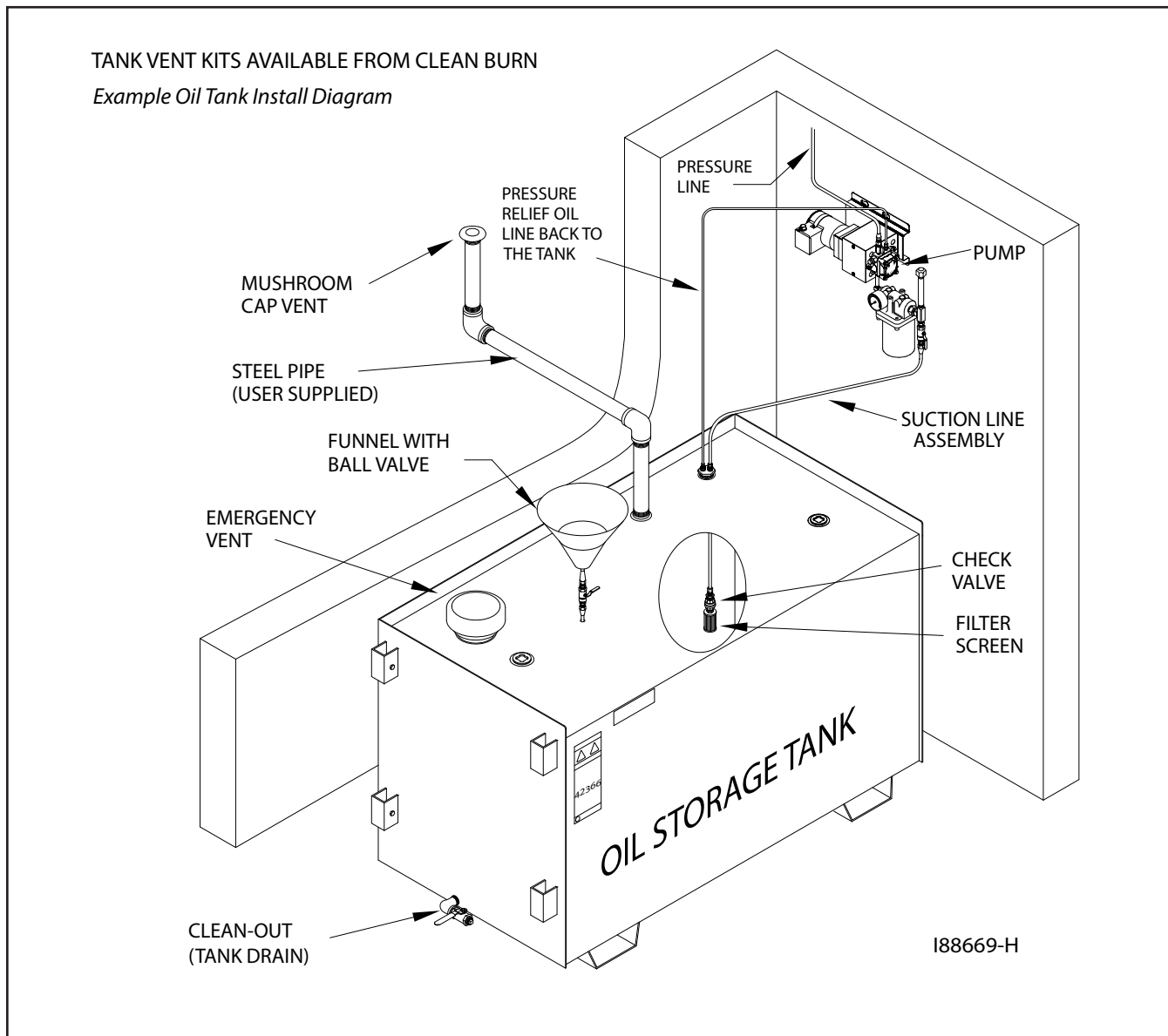

Figure 4F - Typical Metering Pump Installation with Inside Tank

Installing the Tank Vent and Emergency Vent

Some codes require that you install a tank vent (to the outside) and an emergency vent for your tank as shown in Figure 4F. **Tank Vent Kits** are available from Clean Burn; contact your local Clean Burn dealer to order. Be sure to check your local codes for any additional tank installation requirements, and adhere to the following installation guidelines:

- Install a length of minimum 2" steel pipe (user-supplied) terminating outside with a proper vent cap as shown in Figure 4F. Consult local codes for information and requirements concerning the proper venting of oil storage tanks.
- Install an emergency vent as shown in Figure 4F. Contact your tank manufacturer for information concerning the proper emergency vent for your tank.

Installing the Metering Pump

Preparing for Installation

Before starting installation of the metering pump, review Figures 4G, 4H, and 4I to become familiar with the metering pump components. You will also need to accomplish the following activities:

- Verify that you have the proper metering pump for your furnace (note the specific gear motor part numbers shown in Figure 4H).
- Gather all required tools and materials as needed for installation; as indicated in the following procedures, some materials (e.g. fittings, tubing) are to be user-supplied.
- *Standard mounting* is vertical mounting on a wall; **this pump installation is recommended.** *Alternate mounting* is horizontal mounting on a bracket. Be sure to carefully follow the appropriate procedures/diagrams for pump mounting.
- For optimal metering pump functioning, mount the pump at a distance from the oil tank that will comply with the following requirements:
The suction oil line may NOT exceed **6 feet TOTAL vertical lift AND 4 feet TOTAL horizontal lift.**

Standard Mounting: Vertical Positioning

1. Refer to Figures 4G, 4H, and 4I. Note that the metering pump is shipped with the pump head already positioned for vertical wall mounting.
2. Use the appropriate type of bolts and washers (user-supplied) to securely mount the metering pump to the appropriate wall in your building at a distance from the tank that complies with the suction oil line requirements.

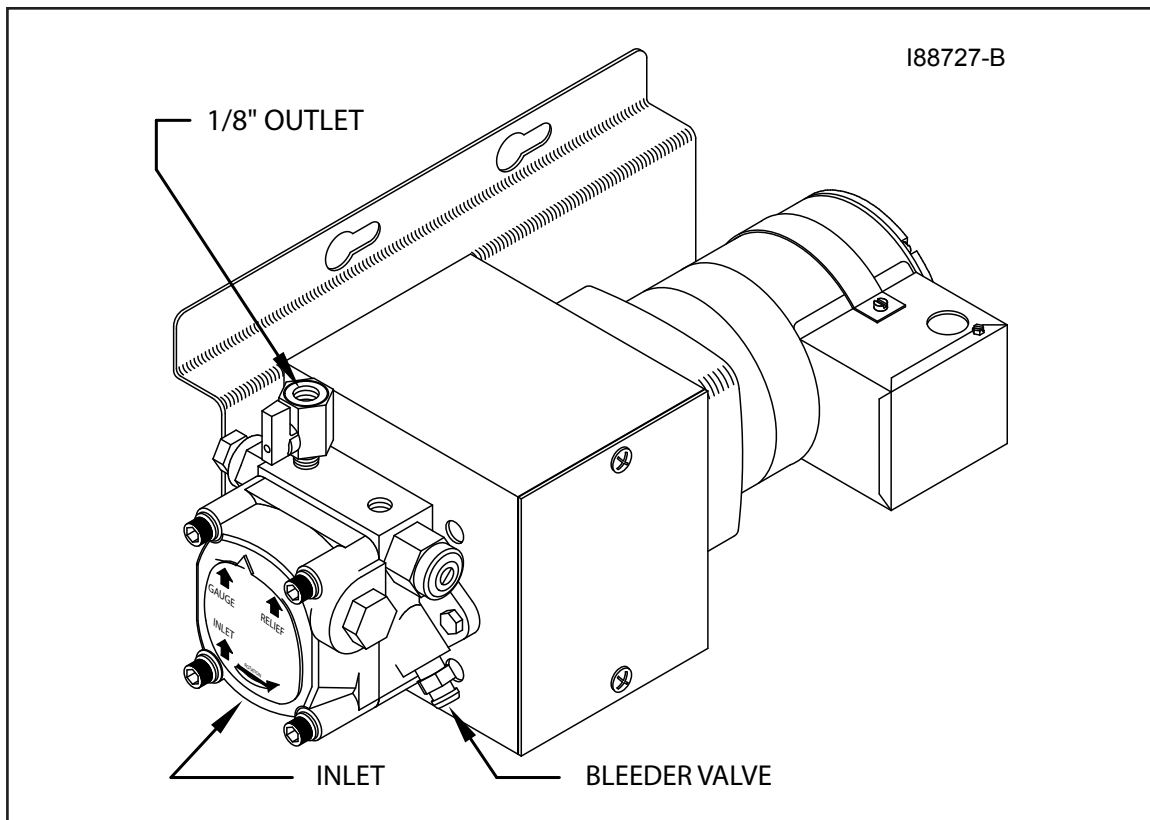

Figure 4G - Vertical Mounting of the Metering Pump

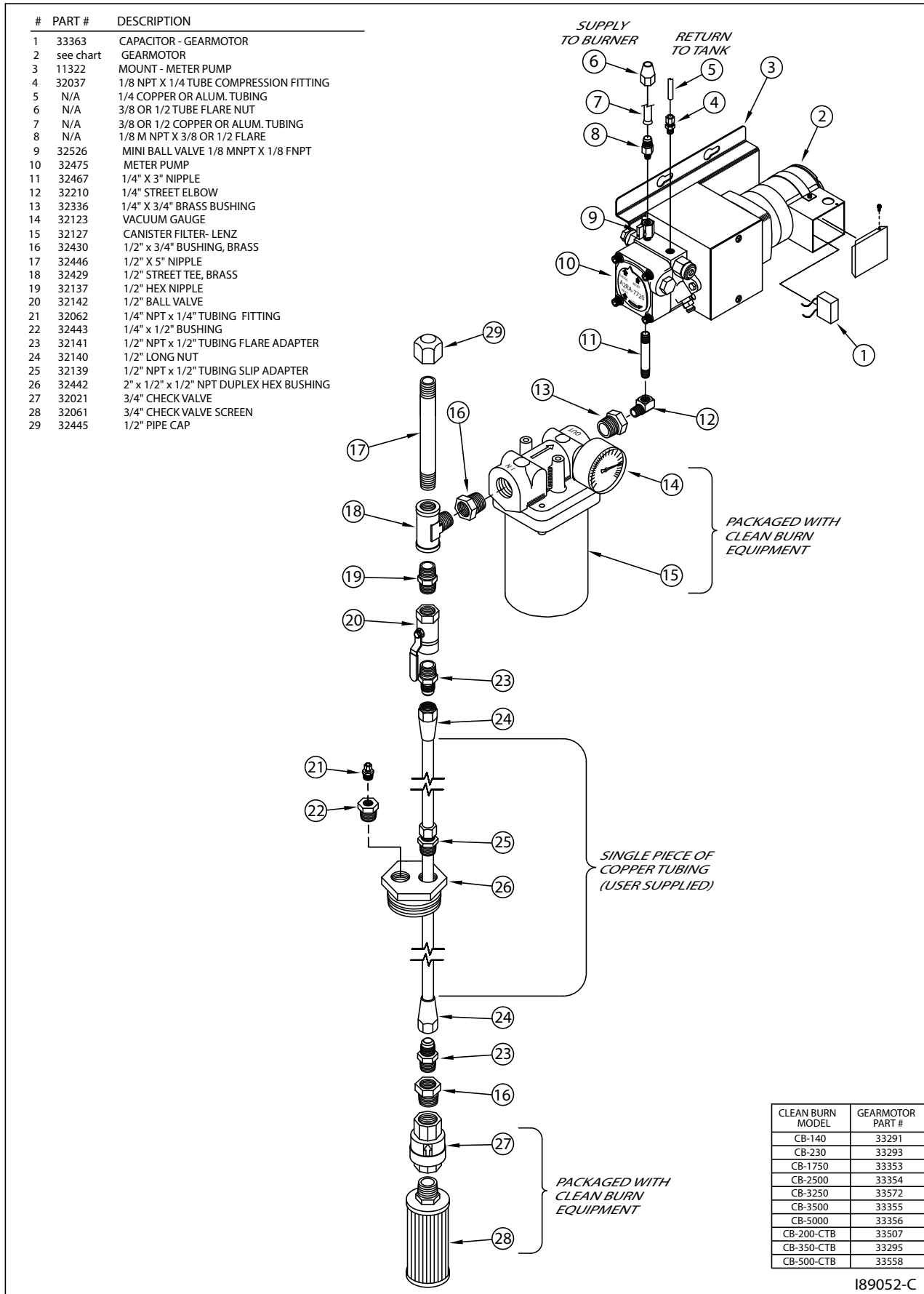

Figure 4H - Metering Pump Component Detail

Installing the Metering Pump (continued)

Alternate Mounting: Horizontal Positioning

ATTENTION: If the metering pump is to be mounted horizontally or on a bracket as shown in Figure 4I, the pump head must be rotated counterclockwise so that it is aligned in a horizontal position. *The gauge arrow on the pump head must point up, or the pump will not prime.*

1. Refer to Figures 4H and 4I.
2. Remove the two pump mounting bolts. The coupling is keyed and does not have set screws.
3. Rotate the pump head 180 degrees to the horizontal position as shown in Figure 4I.
4. Re-install and tighten the two pump mounting bolts.
5. Use the appropriate type of bolts and washers (user-supplied) to securely mount the metering pump to the mounting bracket, which is to be installed on the appropriate wall in your building at a distance from the tank that complies with the suction oil line requirements.

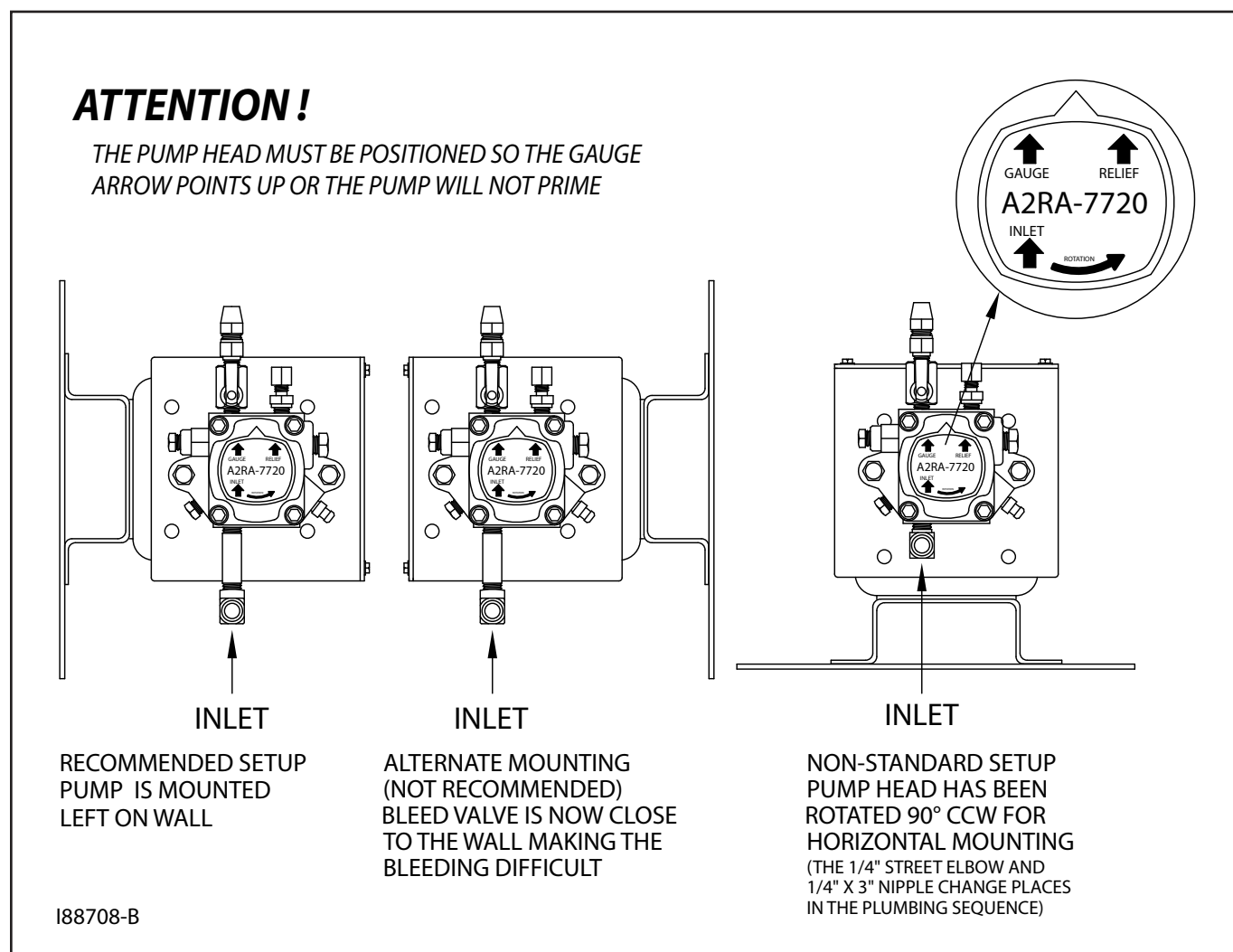

Figure 4I - Proper Positioning of Metering Pump Head

Wiring the Furnace and Pump



WARNING: To avoid electrical shock, make sure that power to the furnace is turned OFF before connecting any wires. A licensed electrician should install all wiring to your furnace. All wiring must be in accordance with the National Uniform Electrical Code and local codes. Properly size all wires and use electrical conduit for all electrical lines.

Wiring your furnace involves the installation of two lines:

- (1) A dedicated electrical line to the furnace
- (2) A pump electrical circuit from the furnace to the metering pump

Necessary wiring specifications are provided in this section and in the **Wiring Schematics** located in **Appendix B** at the back of the manual.

Wiring to the Furnace

1. Install a *dedicated electrical circuit* to the electrical junction box on the furnace. Refer to NFPA-70 for wire size and distances



WARNING: DO NOT tie into an *existing* circuit, or electrical overload may occur.

2. Wire the furnace according to the Wiring Schematic, Figure B1, in Appendix B. **Ensure that the ground wire is attached to the GREEN ground screw on the furnace junction box.**
3. Check for correct voltage at the furnace, and refer to the following chart.
ATTENTION: Incorrect voltage will severely damage the blower motor/furnace components. DO NOT operate your furnace on any non-specification power system.

Model	Voltage	Breaker Size*	Circuit	Hertz
CB-3500	208/240	30/30 amps	Dedicated	60
CB-3500 (w/Options)	208/240	35/35 amps*	Dedicated	60
CB-5000	208/240	30/30 amps	Dedicated	60
CB-5000 (w/Options)	208/240	35/35 amps*	Dedicated	60

*NOTE: When installing any optional equipment (e.g. air compressor or draft inducer), please refer to the "w/Options" breaker size above. Make sure a qualified electrician properly sizes and installs this electrical circuit. **Refer to NFPA-70 for wire size and distances.**

4. DO NOT turn on main power until instructed to do so.

Wiring to the Metering Pump



WARNING: DO NOT wire the pump directly into your building's electrical system. The pump must be activated (receive power) from the burner via the pump electrical circuit. DO NOT wire the pump directly to a wall outlet so that it runs continuously; this will seriously damage your metering pump and/or furnace and may result in a fire or explosion hazard.

1. Install the pump electrical circuit from the furnace to the metering pump location.
2. Wire the pump circuit according to the **Metering Pump Wiring Schematic** in Appendix B at the back of this manual.

Installing the Suction Oil Line Components

ATTENTION: It is critical that you adhere to the following specifications for suction oil line installation (*oil line from the tank to the pump*). If these specifications are not met, the metering pump will not function correctly and the burner will shut down on reset. The majority of service problems with the metering pump are caused by leaks at fittings in the suction oil line; these problems are eliminated by ensuring a 100% airtight suction oil line which slants up to the pump.

- All suction oil line components must be installed as shown in Figures 4H and 4J. **Suction line size is 1/2" diameter.** Proper installation allows the suction oil line to be filled with used oil during initial priming.
- The suction oil line may NOT exceed **6 feet TOTAL vertical lift AND 4 feet TOTAL horizontal lift** (*which equals 6.0" hg maximum operating vacuum*). To determine if your suction oil line will meet this specification for maximum operating vacuum, base the calculation for your installation on the following equivalents:
 - (1) vertical foot = 0.75" hg (vacuum)
 - (4) horizontal feet = 0.75" hg (vacuum)

NOTE: ALSO ADD 0.75" hg to the final sum to account for every oil filter, shut-off valve, and check valve on the suction side of the pump assembly.

Sample calculation: (6) vertical feet x 0.75" = 4.50" hg AND (4) horizontal feet = 0.75" hg
4.50" hg + 0.75" hg + 0.75" hg = 6.00" hg vacuum

- The metering pump must be installed with a **3/4" check valve and screen** at the end of the suction oil line, or the pump will not maintain its prime.
 - Use **Permatex #2 non-hardening gasket sealer** on every threaded fitting. DO NOT use teflon tape or teflon pipe dope compounds; the teflon can flake off and cause damage to the pump head.
 - **The suction oil line must be 100% airtight for proper system functioning.** Use only high-quality flare fittings for the copper tubing. DO NOT use compression fittings. DO NOT use any steel pipe unions. DO NOT use sweat copper pipe. These types of fittings cause air leaks in the suction oil line and will require re-installation.
 - **The suction oil line must slant up to the pump;** any high spots will trap air and will not allow the pump to prime.
1. **Assemble the suction oil line fittings (*from the metering pump to the canister filter*):**
 - a. Refer to Figure 4H for a detailed look at the metering pump components and fittings.
 - b. Remove the plug from the 1/4" inlet port of the pump.
 - c. Install the 1/4" x 3" brass nipple into the 1/4" inlet port on the pump.
 - d. Install the 1/4" brass street elbow onto the 3" brass nipple; turn the fitting onto the nipple until it is tight and faces away from the pump mounting plate.
 - e. Prepare the canister filter for installation:
 - Install the 3/4" x 1/4" brass hex bushing into the outlet port of the canister filter.
Check the direction of the arrow for the proper flow.
 - Install the 3/4" x 1/2" brass bushing into the inlet port of the canister filter.
 - Remove the plug from one of the 1/8" gauge ports in the canister filter and install the vacuum gauge. Seal the threads of the gauge with Permatex #2 non-hardening gasket sealer.
 - Install the 1/2" threaded pipe adapter into one side of the 1/2" ball valve.
 - Install the 1/2" MPT x 1/2" flare adapter into the other side of the ball valve.

Installing the Suction Oil Line Components (continued)

- (1.) (e.) Prepare the canister filter for installation (*continued*):
- Install this assembly into one side of the 1/2" brass tee.
 - Install the assembled 1/2" tee into the 3/4" x 1/2" brass bushing, which is installed in the inlet port of the canister filter. Make sure that the 1/2" flare adapter is pointing down.
 - Install the canister filter assembly onto the 1/4" brass street elbow as shown in Figure 4H. The canister filter must be installed with the arrow pointing towards the pump (direction of oil flow).
 - Install the 1/2" x 5" brass nipple into the top side of the 1/2" brass tee assembly.
 - Loosely install the 1/2" brass cap onto this nipple; DO NOT tighten the cap at this time.

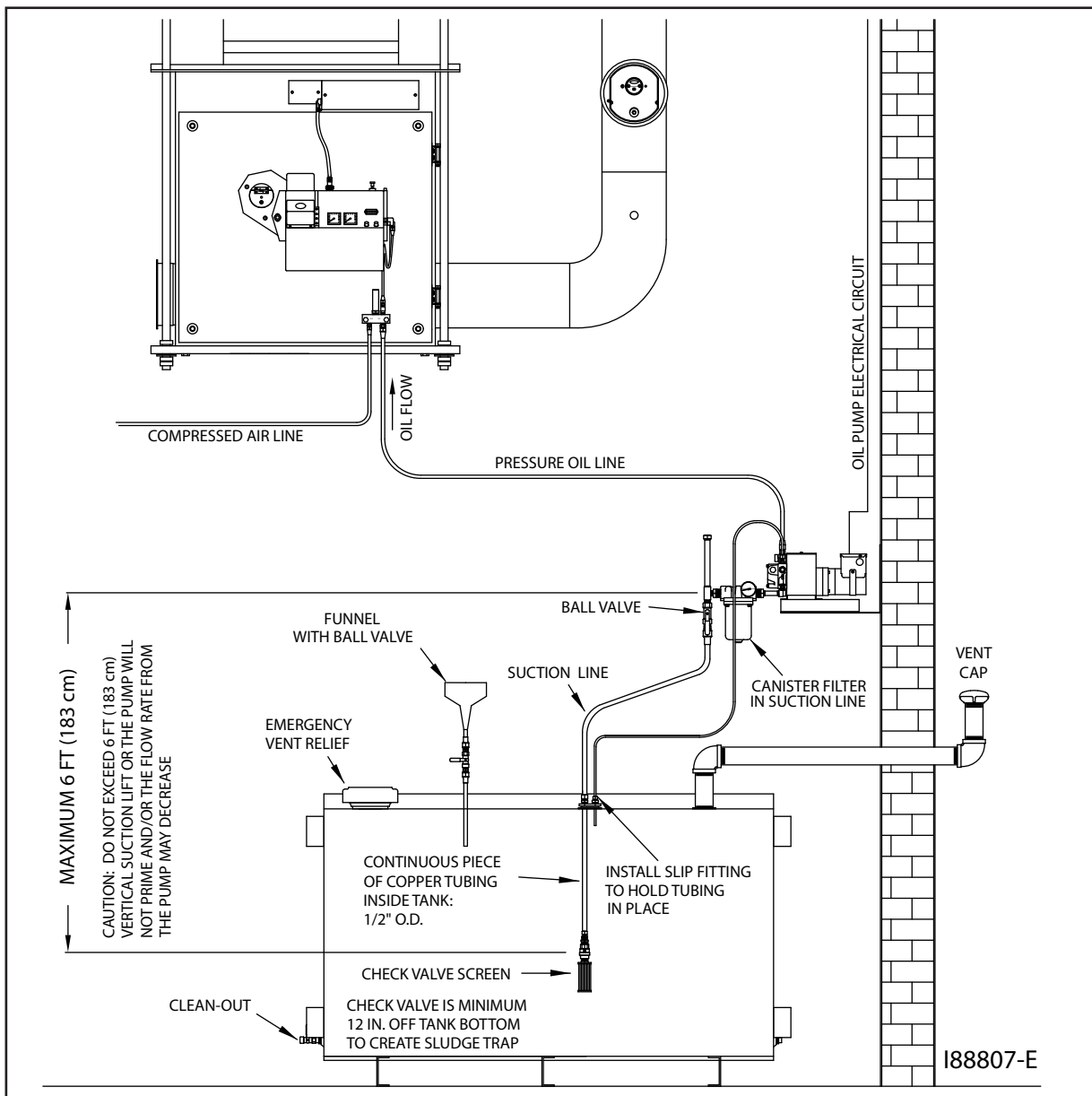

Figure 4J - Oil Line Installation Overview

2. **Install the suction oil line (from the tank to the canister filter):**
- a. Refer to Figures 4H and 4J. Prepare a piece of 1/2" O.D. copper tubing (user-supplied) which will function as the pick-up line from the tank to the canister filter. This copper tubing must have the following specifications:
 - The tube must be one continuous piece of 1/2" O.D. copper tubing with no kinks or fittings.
 - The tube is to slant up from the tank to the pump with no loops or high points to trap air.
 - c. Locate the 2" MPT x 1/2" FPT x 1/2" FPT duplex, slip-thru hex bushing (which will eventually be installed into one of the 2" openings on the tank). *Note that the fitting is marked "S" for suction and "R" for return.*
 - d. Install the 1/2" MPT x 1/2" slip fitting into the "S" side of the 2" duplex slip-thru hex bushing.
 - e. Install the 1/4" MPT x 1/4" compression fitting into the 1/2" x 1/4" brass bushing.
 - f. Install the 1/2" x 1/4" brass bushing into the "R" side of the 2" duplex slip-thru hex bushing.
 - g. Measure the height of the oil tank (from the bottom of the tank, NOT the floor) to the 2" opening that you are going to use for the supply oil line. Deduct 12" (305mm) from this measurement and transfer this new measurement onto the 1/2" O.D. copper tubing.
 - h. Remove the locking nut and ferrel sleeve connector from the 1/2" slip fitting, and slide them over the copper tubing.
 - i. Slide the 1/2" O.D. copper tubing through the 1/2" slip fitting, which is installed in the "S" side of the 2" hex bushing.
 - j. Install the screen into one side of the 3/4" check valve (making sure the arrow is pointing away from the screen assembly).
 - k. Install the 3/4" x 1/2" brass bushing into the 3/4" check valve.
 - l. Install the 1/2" MPT x 1/2" flare adapter into the 3/4" x 1/2" brass bushing.
 - m. Slide the 1/2" flare nut over the end of the 1/2" copper tubing, and flare the end of the tubing. **NOTE:** Use a high-quality flaring tool (such as a Ridgid Flaring Tool) to ensure that all flares are made properly (i.e. so they will be 100% airtight).
 - n. Install the flared oil line and nut onto the assembled check valve/screen and tighten.
 - o. Pick up the assembled oil line, and carefully guide the end of the tubing with the check valve through the 2" tank opening.
 - p. Apply Permatex #2 non-hardening gasket sealer (or equivalent) to the threads of the 2" duplex slip-thru tank bushing, and tighten this fitting into the tank.
 - q. Pull the 1/2" copper tubing back up through the slip fitting until you see the mark that you put on the tubing earlier. Holding the tubing with one hand, push the ferrel sleeve connector and locking nut down the tubing, then tighten onto the 1/2" slip fitting. The oil line is now installed in the correct position off of the bottom of the tank.
 - r. Carefully bend the oil line up to the canister filter; use a spring bender over the oil line while bending the tubing to prevent kinks in the oil line. Allowing for the flare nut, cut off the excess tubing.
 - s. Install the 1/2" flare nut onto the tubing, and flare the end of the tubing.
 - t. Install the end of the tubing with the flare nut onto the 1/2" flare adapter (on the ball valve assembly at the canister filter).
 - u. Install a vent from the tank to the outside of the building according to code. The tank must be properly vented to allow air to enter the tank as oil is pumped out and to safely vent fumes to the outside. See Figures 4J.
 - v. Install plugs in all other tank openings as required by code.
 - w. Inspect the installation. For proper suction oil line operation, make sure all components are installed and positioned as specified in this manual.

Installing the Pressure Relief Oil Line Back to the Tank

ATTENTION: It is critical that you adhere to the following specifications for plumbing the pressure relief back to the tank.

The metering pump requires the installation of a pressure relief oil line back to the tank that you are pulling oil from as shown in Figures 4F, and 4J.

- The **pressure relief** will open and relieve pressure if there is a restriction in the pressure oil line, clogged nozzle, etc.

Be sure to use Permatex #2 non-hardening gasket sealer to seal every threaded fitting. DO NOT use teflon tape or teflon pipe dope compounds.

1. Refer to Figure 4K.
2. Remove the plug from the relief port on top of the metering pump head.
3. Install the 1/8 NPT x 1/4 tube compression fitting in the relief port on top of the metering pump head.
4. Install 1/4" O.D. copper tubing (user-supplied) from the pressure relief port back to the oil tank. Refer to Figure 4J as needed.

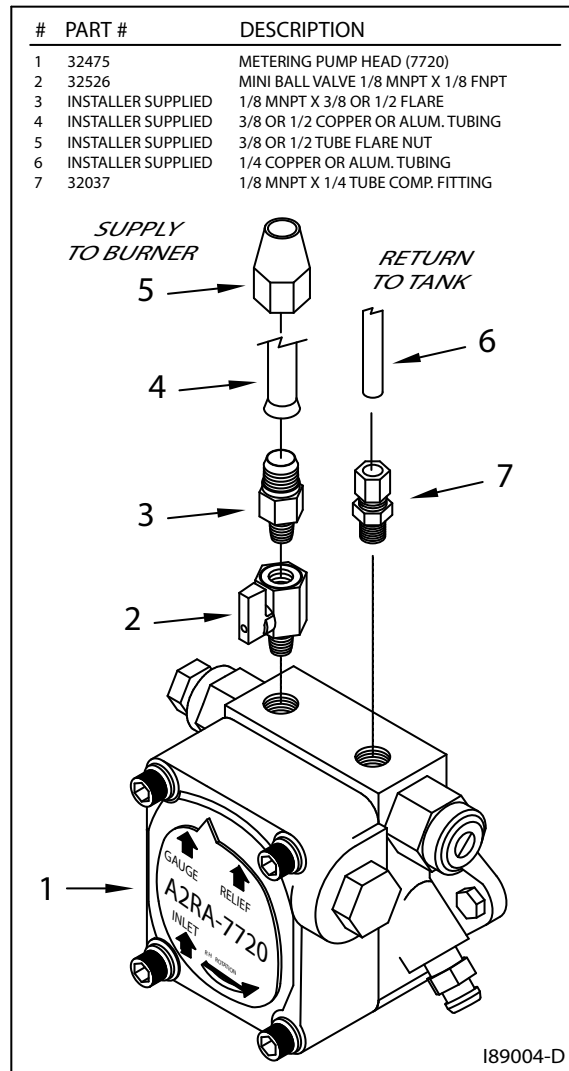

Figure 4K - Pressure Relief Oil Line Back to the Tank

Installing the Pressure Oil Line Components

ATTENTION: It is critical that you adhere to the following specifications for pressure oil line installation (oil line from the pump to the furnace); if these specifications are not met, the metering pump will not function correctly and the burner will shut down on reset.

- The parameters for pressure oil line installation are:

<u>Length of Pressure Line</u>	<u>Line Size</u>
Up to 100 feet	3/8" O.D. copper tubing

(Please note that some installations will allow for a greater pressure line length. Contact your Authorized Clean Burn Distributor for more information.)

- **The pressure oil line must slant up to the burner** with no loops or high points to trap air.
 - Local codes may require the installation of an in-line "**Fire-O-Matic**" safety valve. Be sure to check all appropriate codes to ensure compliance.
1. Refer to Figures 4H, 4J, and 4K.
 2. Make sure you have purchased all the necessary fittings to complete the installation correctly.
 3. Install the fittings and components as shown in the related illustrations. Be sure to use Permatex #2 non-hardening gasket sealer to seal every threaded fitting. DO NOT use teflon tape or teflon pipe dope compounds.

Installing the Compressed Air Line

NOTE: Your air compressor system must supply air pressure to the furnace with the following requirements: **50 psi and water trap or dryer**. If you do not have shop air, an optional air compressor is available. Contact your local Clean Burn dealer for more information.

1. Run a compressed air line from your shop air to the connector block on the furnace -- for Model CB-3500 use minimum 1/4" O.D. copper tubing or equivalent; for Model CB-5000, use 3/8" O.D. copper tubing or equivalent.
2. Install an easily accessible shut-off valve in the air line so the burner can be serviced without shutting off the shop air in your service area.
3. If necessary, install a pressure regulator (additional to the burner air regulator) in the air line, and set it at 50 psi.

ATTENTION: DO NOT feed full shop air pressure to the burner or damage to burner components may occur.
4. Install a water trap or extractor/dryer in the air line with an automatic drain so compressed air (rather than water) is supplied to the burner.

ATTENTION: Water must not be fed to the burner, or the flame will be extinguished and the burner will shut down. Be sure to drain water from your compressor tank on a regular basis to keep water out of the air line.

Installing the Stack



WARNING: Inappropriate stack materials or improper stack design/installation can adversely affect the proper, safe operation of your furnace. Contact your Clean Burn dealer to purchase the proper stack components for your furnace.

Stack designs are generally classified as follows:

- (1) "Class A" stack through the ceiling of the building (refer to **Figure 4L**)
- (2) "Class A" stack through the sidewall and up the side of the building (refer to **Figure 4M**)

Stack Design and Specifications

ATTENTION: *The stack design must be single and dedicated for each unit (furnace) according to the following specifications.* A single stack serving more than one unit **MUST** be engineered/certified for that specific installation (ref. NFPA 211, 3.3.39 and 10.2.1; NFPA 31 6.5.16-18). Failure to adhere to this rule may result in less than optimal system performance.

Figures 4L and 4M illustrate recommended stack designs. Choose the stack design which is appropriate for your furnace installation and review all specifications provided in the corresponding drawing. When designing your stack, adhere to the following specifications:

- Model CB-3500 requires **minimum 8" I.D. stack components.**
Model CB-5000 requires **minimum 10" I.D. stack components.**
- *Ensure that the vertical stack height is **at least 10 feet PLUS 1.5 feet for every fitting** (e.g. 45 degree, 90 degree, or T) in the stack run.* If needed, increase the vertical length of the stack or install a draft inducer to obtain -.02" W.C. draft over fire. (Section 8 contains details on adjusting the draft.)
- *Keep the horizontal stack run as short as possible; slant it upward at a minimum of 1/4" per foot of run.*
- *Keep the stack design simple.* Complicated stacks (with long runs and many turns) reduce draft and result in poor burner performance. **Your stack may include only one 90 degree turn.** All other stack turns must be at 45 degrees or less to ensure optimal draft and burner performance.

NOTE: If you plan to use an existing masonry chimney, the chimney must be *lined* and *inside* the building. Exterior masonry chimneys chill the stack gases and result in poor draft and poor burner performance.

ATTENTION: *If you have an exhaust fan(s) in your shop, it is critical that you have adequate make up air (source of fresh air to replace the stale air exhausted by the fan).* When an exhaust fan is run without adequate make up air, the resultant vacuum in the building will draw combustion products back into the burner. This back draft causes poor burner performance and may damage vital burner components. Refer to Section 8 in this manual for additional information.

Stack components should be installed in the following order:

- (1) Inside stack (*stack components from furnace breach to within 18" of ceiling, roof, or sidewall of building*)
- (2) Barometric damper
- (3) "Class A" stack penetration through the ceiling, roof, or sidewall
- (4) "Class A" stack on the exterior of the building
- (5) "Class A" stack cap
- (6) Draft Inducer (*standard component for Model CB-5000; optional accessory for Model CB-3500*)

Installing the Interior Stack



WARNING: Single wall stack components may be used *only* for those portions of the stack which are located inside your building and away from any fire/burn hazards.

1. Install the single wall stack with proper clearances from combustibles. Also ensure that the stack is located a safe distance from all shop personnel.
2. Install an elbow at the junction of the horizontal and vertical stack components to allow for easy cleaning of the stack.

ATTENTION: Avoid additional 90-degree turns in the stack. Each additional 90-degree turn slows down stack gases, creates back-pressure, and results in repeated burner shutdown and unnecessary service calls. All other turns in the stack should be at a 45-degree (or smaller) angle.

NOTE: IMPORTANT for Canadian Installations - Local codes may require the installation of a clean-out tee.

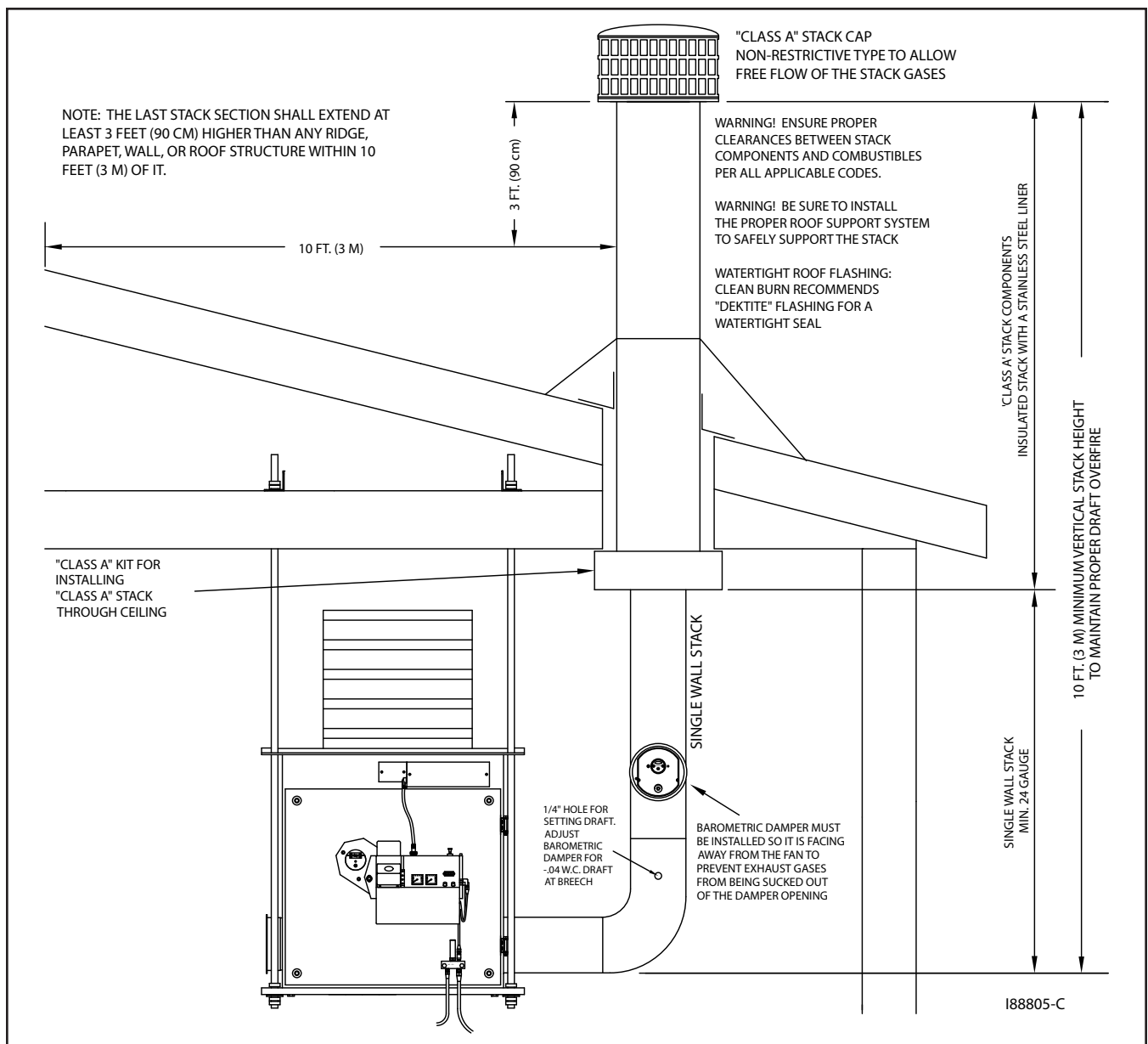

Figure 4L - Installation of "Class A" Stack Through Roof/Ceiling

Installing the Stack (continued)

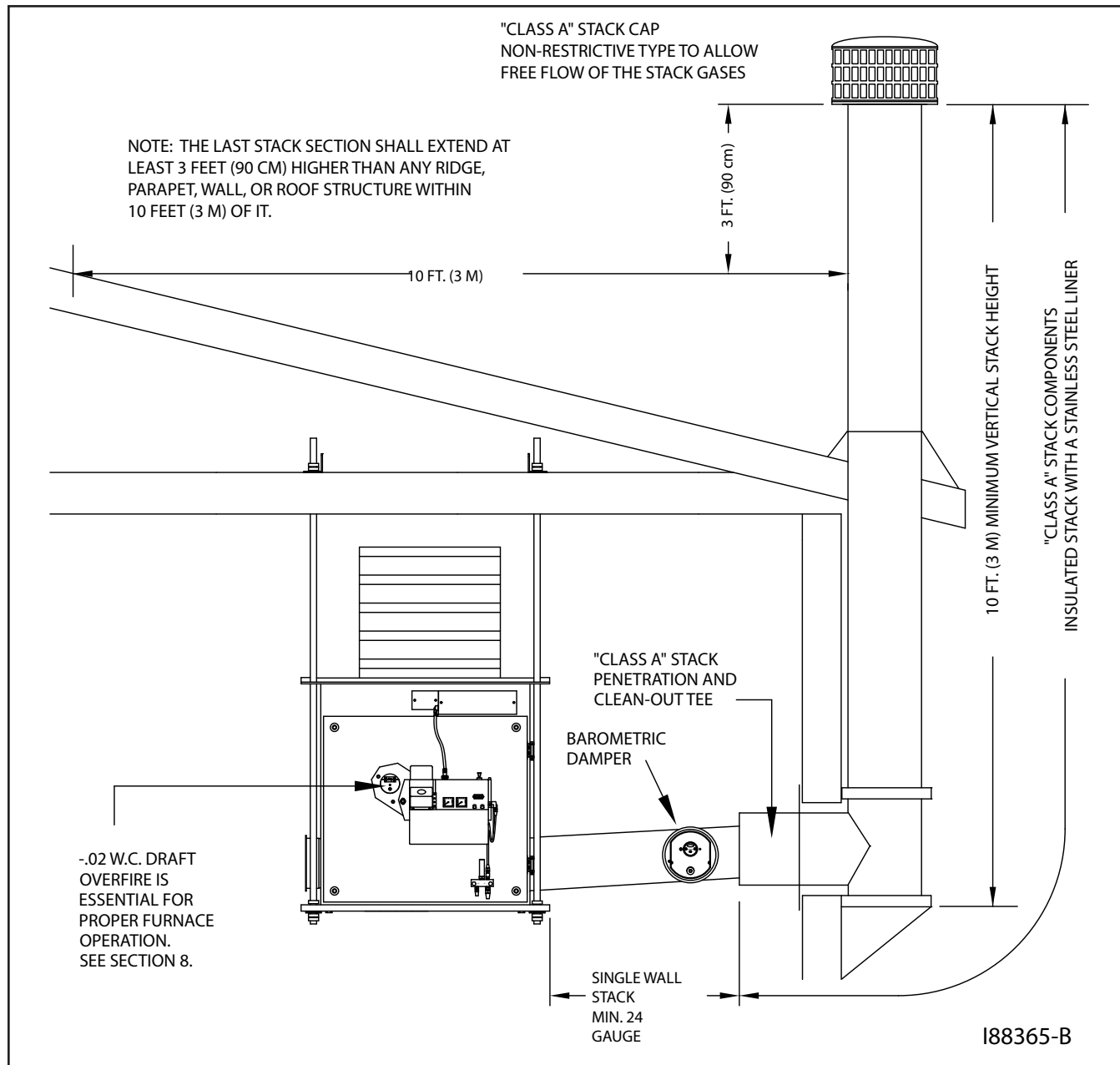

Figure 4M - Installation of "Class A" Stack Through Sidewall

Installing the Barometric Damper

1. Refer to the stack installation drawing, Figure 4L. Install a single wall tee (min. 24 gauge) after the 90-degree elbow in the straight vertical stack section within three to five feet of the furnace breach. For horizontal stack runs (as shown in Figure 4M), install the tee after the first straight section of pipe.
NOTE: The tee is required to support the barometric damper. You must purchase this tee when you purchase your stack materials (8" single wall tee - CB#70174 for CB-3500; 10" single wall tee - CB#70180 for CB-5000).
2. **For CB-5000 ONLY:** Install the 9"-to-10" pipe adapter in the opening of the tee as shown in Figure 4N.
3. Install the barometric damper in the opening of the tee (or pipe adapter for CB-5000 furnaces). Use a small spirit level to make sure that it is properly level.
4. Install two self-tapping screws (i.e. one on each side of the barometric damper) to hold the damper in place as shown in Figures 4N and 4O. **DO NOT** install a screw at the bottom of the barometric damper, or the flapper of the damper will not operate correctly.

NOTE: Specifications for adjusting the barometric damper for proper draft overfire are provided in **Section 8** of this manual.

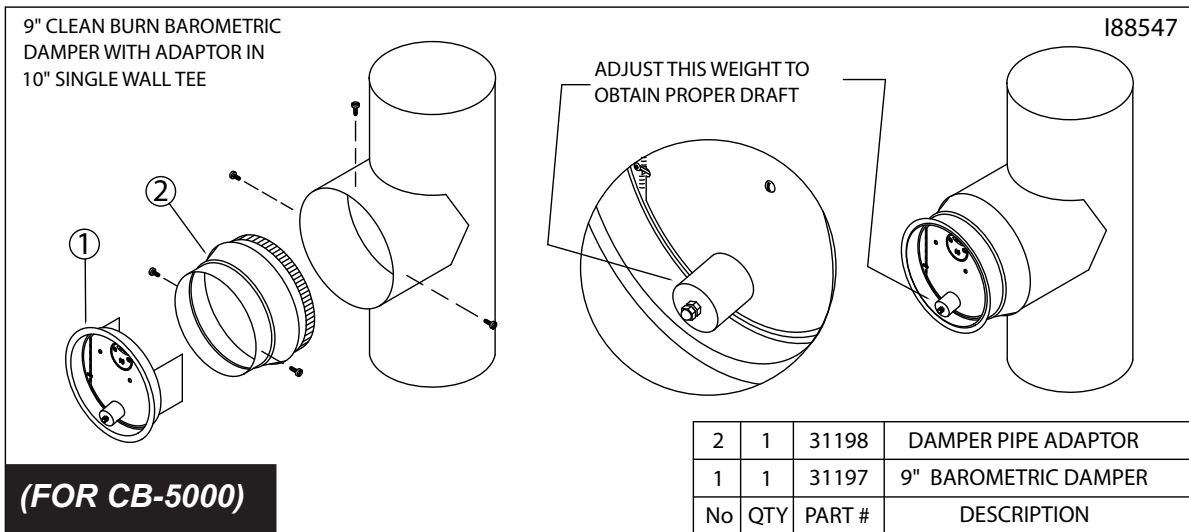

Figure 4N - Installation of 9" Barometric Damper for Model CB-5000 Furnaces

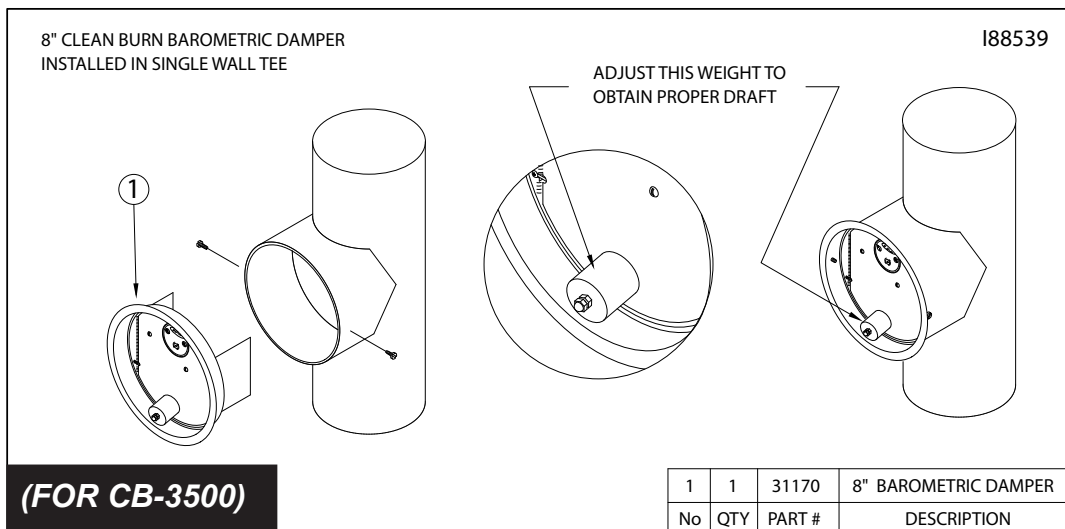

Figure 4O - Installation of 8" Barometric Damper for Model CB-3500 Furnaces

Installing the Stack Safety Switch For Canadian Installations

NOTE: CSA Standards require that all heating equipment must be installed with a stack safety switch. If your heating equipment is being installed in Canada, follow the instructions listed below.



CAUTION: For your safety and the safe operation of your heating equipment, the stack switch must be installed by a qualified installer in accordance with the installation instructions provided here. Wiring must be accomplished in accordance with all applicable codes. Failure to adhere to these safety recommendations may result in serious personal injury and/or equipment damage.

1. Follow the instructions in the *Operator's Manual, Section 4* to install a proper stack, including the barometric damper which must be installed within 40 inches of the breach.
NOTE: The barometric damper must be installed so that it is level and the flapper moves freely.
2. Ensure that main power to the heating equipment is turned OFF.
3. Position the stack safety switch over the lip of the barometric damper as shown in Figure 4P.
4. Drill a 1/8" pilot hole for the mounting screw, and mount the stack safety switch using the mounting screw supplied with the switch.
NOTE: The mounting screw must not interfere with the free movement of the flapper on the barometric damper.
5. Install the wall thermostat according to the instructions provided in the *Operator's Manual, Section 4*. Wire the wall thermostat and stack safety switch in series as shown in Figure 4Q. Install the wire so that it is secured away from any hot surfaces.
6. When the heating equipment installation is completed, follow the instructions in the *Operator's Manual, Sections 5 and 6* to prime the pump and start/adjust the burner.
7. Follow instructions in the *Operator's Manual, Section 8* to check the draft; this is crucial for the proper, safe operation of the heating equipment.

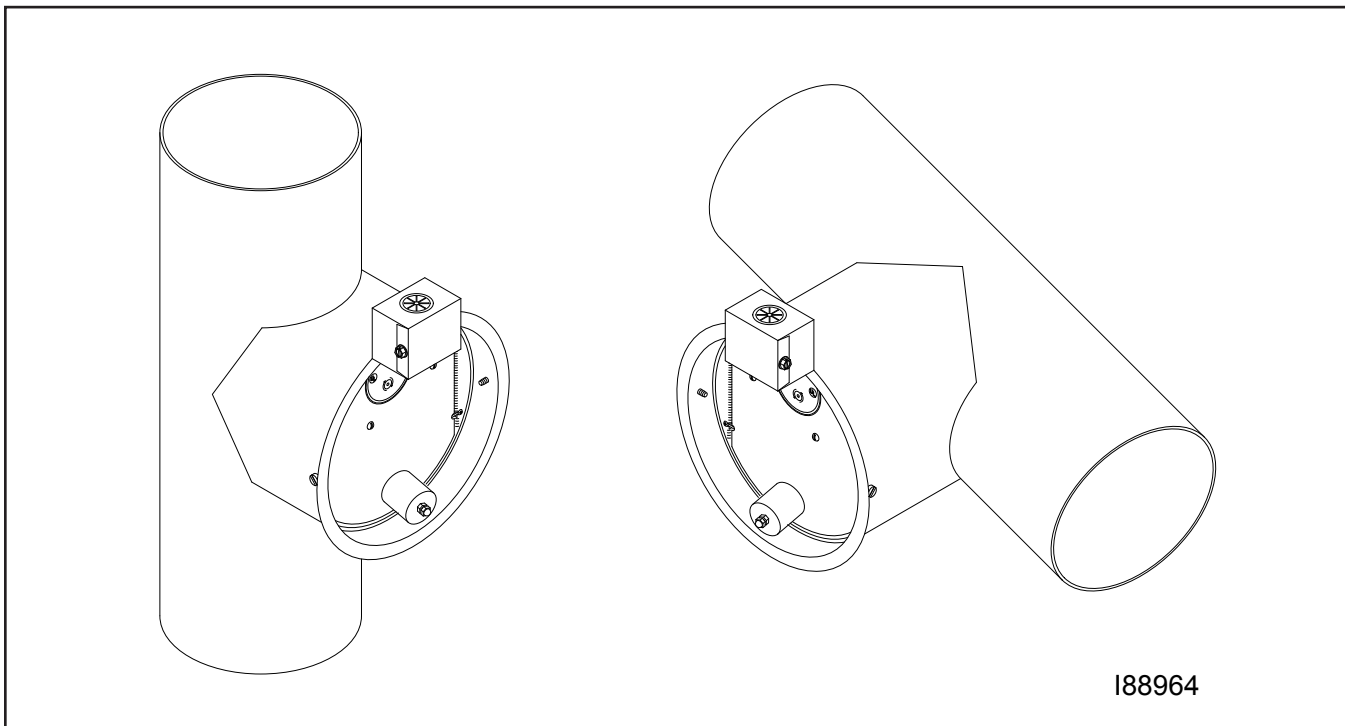

Figure 4P - Stack Safety Switch Installed on the Barometric Damper

Resetting the Stack Safety Switch

WARNING: BURN HAZARD! To prevent serious personal injury, be sure to allow ample time, at least 30 minutes, for the stack, barometric damper, and switch to cool down before attempting to access and service these components. It is crucial to identify the cause of the stack obstruction (e.g. heavy snowfall) and correct it *before* resetting the stack safety switch and re-starting the burner. **DO NOT operate the heating equipment with an obstructed stack;** failure to correct an obstructed stack may result in fire, explosion, and/or burn hazards causing serious personal injury or death.

NOTE: In locations where heavy snowfall occurs, it is critical that the stack remain unobstructed by snow. For safe heating equipment operation, be sure to keep the area surrounding the stack clear of snow.

1. Before resetting the stack safety switch, check the stack to make sure it is clear of any obstructions.
2. Remove the cover from the stack safety switch, and push the small button in the middle of the switch.
3. Pushing the stack safety switch reset button will re-establish the thermostat circuit, and the burner will start (assuming the wall thermostat is calling for heat).

Understanding the Function of the Stack Safety Switch

The **Stack Safety Switch** monitors the temperature at the barometric damper on the stack and is designed to detect the obstruction of the free flow of stack gases from the heating equipment and shut down the burner. Obstruction of the stack results in the “spillage” of stack gases from the barometric damper, which heats up the switch. The switch then opens, disconnecting the thermostat circuit to the burner, and the burner shuts off.

Stack Safety Switch Specifications

Switching Voltage	24 volts
Switch OPEN Temperature	180 degrees F
Switch Type	L180, normally closed, manual reset

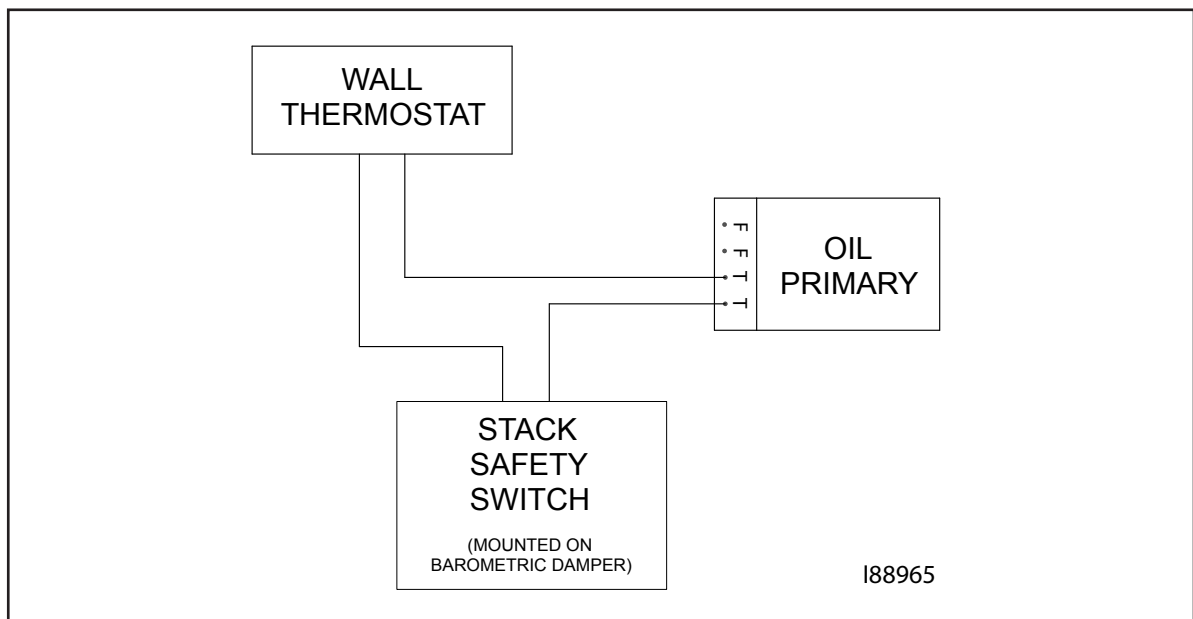

Figure 4Q - Stack Safety Switch Wiring Diagram

Installing the Stack Penetration



WARNING: When running the stack through your ceiling, roof, or sidewall, you must use **Class A/UL 103 HT double-wall insulated all-fuel stack components** with a stainless steel liner. **DO NOT** run single-wall stack through your ceiling, roof or sidewall. **NEVER** locate a stack joint inside walls or in a joist spacer. Ensure proper clearances from combustibles per all applicable codes.

1. Refer to Figure 4L/4M as needed.
2. Follow the installation instructions provided by the stack manufacturer.

Installing the Exterior Stack

ATTENTION: All exterior stack pieces must be Class A/UL103 HT double-wall insulated all-fuel stack components with a stainless steel liner.

- DO NOT use Class B or BW Vent/double-wall stack components (for gas fired appliances only).
- DO NOT use Type L Vent/double-wall stack components (for approved fuel oil appliances only).
- DO NOT use black stack pipe (for solid fuel burning appliances only).
- DO NOT use single-wall stack for your exterior stack. Single-wall exterior stack chills the stack gases and results in poor draft and poor burner performance.

1. Refer to Figure 4L/4M as needed.
2. Follow the installation instructions provided by the stack manufacturer.
3. Install water-tight roof flashing around the penetration of the exterior stack.

NOTE: Clean Burn recommends the use of "Dektite" roof flashing (or equivalent) which ensures a water-tight seal when installed properly. Contact your local Clean Burn dealer for details.

Installing the Stack Cap

NOTE: Proper installation of a "Class A" stack cap ensures the free flow of stack gases which is essential for optimal burner performance.

1. Refer to Figure 4L/4M as needed. Your stack cap should be classified as: "Class A" non-restrictive, all-fuel type.
2. Install the stack cap according to the manufacturer's instructions.

Installing the Draft Inducer

ATTENTION: The draft inducer, Field brand model DI-3, is standard equipment for CB-5000 furnaces and must be installed to ensure proper draft. The Field brand model DI-2 is available as optional equipment for the CB-3500 furnace. The Field brand draft inducers have been tested for use on Clean Burn furnaces. **DO NOT** use other models or brands of draft inducers.

Understanding the Importance of the Draft Inducer

The draft inducer is designed to aid in the removal of the natural draft created by the appliance to vent the combustion gases to the outside of the building. As the paddle wheel turns, a negative pressure is maintained within the stack so that the combustion gases can leave the furnace and travel out of the stack. (See Figure 4R.) ***Proper sizing, installation, and adjustment of the draft inducer are critical for optimal draft inducer operation.***

Installing the Draft Inducer (continued)

Note: Lubricate the motor as recommended by the Draft Inducer manufacturer.

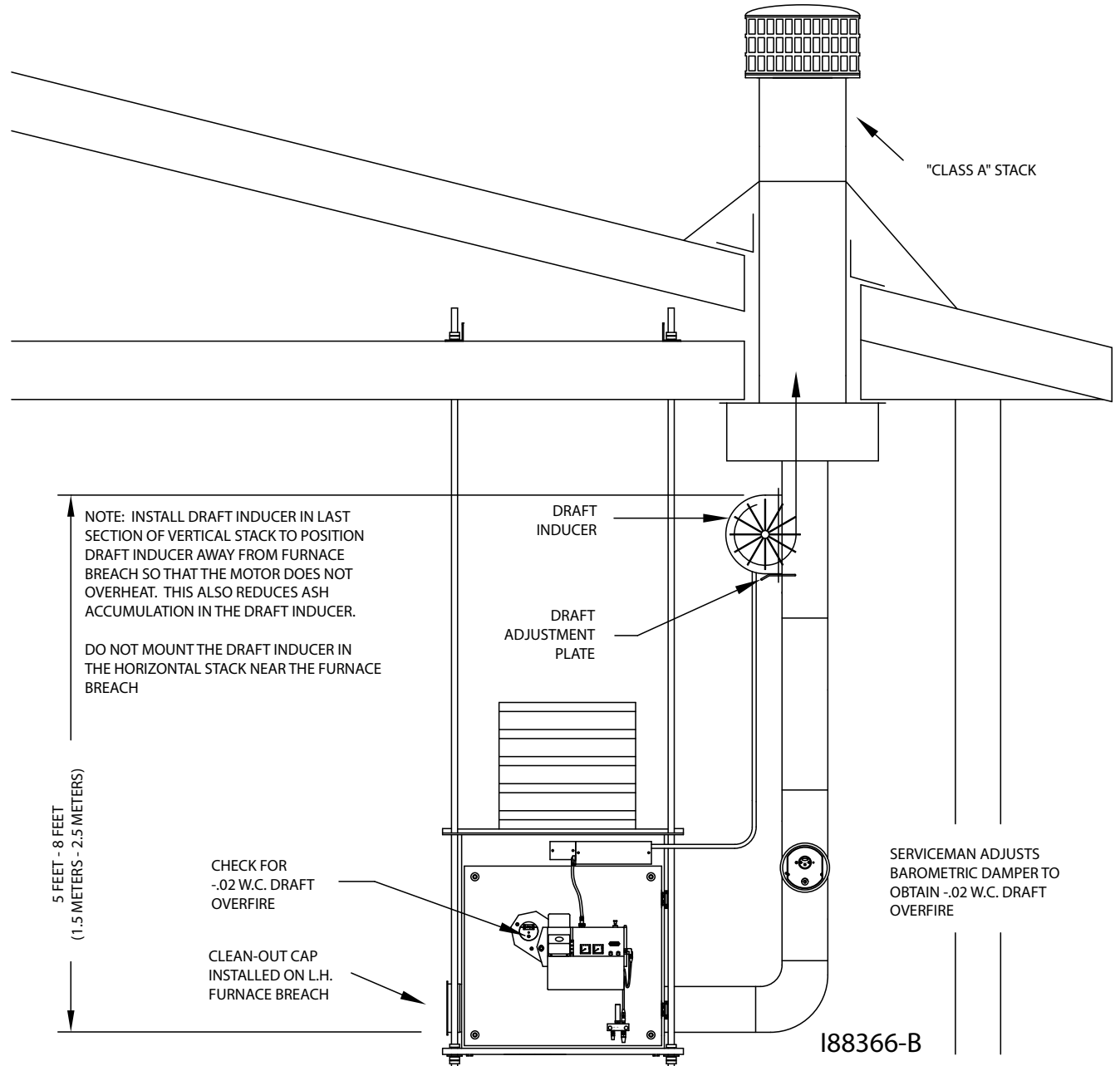

Figure 4R - Installation of the Draft Inducer



WARNING: Turn OFF the main power to the furnace before proceeding with the installation of the draft inducer.

ATTENTION: It is very important to install the draft inducer on a vertical section of stack to isolate the inducer from excessive heat and ash buildup. Never install the draft inducer on a horizontal section of stack close to the furnace breach where heat and ash will damage the inducer motor.

Installing the Draft Inducer (continued)

1. Refer to Figure 4R. Follow the instructions included with the draft inducer to mount the draft inducer on the section of single-wall vertical stack.
2. Position the draft plate all the way out so that it does not reduce the draft produced by the draft inducer. Follow directions in **Section 8 (Adjusting the Draft Overfire)** to set the proper draft.

Wiring the Draft Inducer for Normal Operation*

*(No exhaust fans in the building)

1. Wire the draft inducer according to the **Furnace Wiring Diagram** provided in **Appendix B** at the back of this manual.

Installing the Wall Thermostat

1. Select a location for the thermostat on an interior wall away from any hot or cold drafts.
2. Remove the top cover from the thermostat by pushing gently on the latch at the top center of the body. (*Hold the thermostat base in one hand, and grasp the body with the other hand; push in on the latch with your thumb, and pull the cover away from the base.*)
ATTENTION: DO NOT use a screwdriver to pry the cover off the base, or damage may occur.
3. Remove the green paper insert and the black plastic battery isolator from the battery section of the thermostat.
4. Refer to the **Burner Wiring Diagram** in **Appendix B** at the back of this manual. Run two wire, 18-gauge (minimum) thermostat cable from the terminals on the back of the thermostat base to the T/T terminals of the primary control on the burner.
ATTENTION: NEVER jump between T/T terminals on the primary control without removing one of the wires. Failure to remove one of the wires will burn out the heat anticipator on the thermostat and will cause the thermostat to fail.
5. Mount the thermostat base 60" to 66" from the floor using the hardware provided.
6. Reassemble the thermostat body onto the base. (*Align the hinges at the bottom of the cover with the slots at the bottom of the base, and swing the cover up into place.*)

Replacing the Wall Thermostat Batteries

1. Proper battery level is indicated by the room temperature being displayed on the LCD screen.
2. When the battery level becomes low, a battery icon along with the word "REPLACE" will be displayed in the lower left corner of the LCD screen. Replace the batteries to ensure proper operation, following the previous instructions on the thermostat disassembly procedure.
3. If the batteries are not replaced, the display will slowly become dim and not display any information. The thermostat will eventually not function. If this happens, replace the batteries immediately.

Inspecting the Furnace Installation

Following completion of all installation activities described in this chapter, the furnace should be inspected by qualified personnel before firing. This ensures that your installation meets all applicable national and local codes and allows for any deficiencies to be corrected before furnace startup. *Improper installation may void your warranty.*

SECTION 5: METERING PUMP PRIMING

Understanding Metering Pump Priming

Preparing your Clean Burn furnace for operation begins with priming the metering pump. The procedures in this section must be performed in sequence *without interruption* to properly prime the pump.

Required Tools and Materials

The following tools and materials are required for oil pump priming and should be gathered before starting any procedures:

- 3/8" open-end wrench
- 5/8" open-end wrench
- Rags
- Two containers (minimum one-gallon)
- Permatex #2 non-hardening gasket sealer
- Adjustable Wrench
- Pipe Wrench

Priming the Metering Pump

ATTENTION: *The priming process must be done precisely as described in this procedure to ensure that all air is thoroughly bled from the system.* Failure to bleed all air from the system will result in repeated burner shutdowns on reset.

1. Refer to Figure 5A.
2. Remove the 1/4" NPT plug from the side of the pump head, and set it aside.
3. Remove the 1/2" brass cap from the 1/2" brass nipple. Place a funnel in the opening. Slowly pour used oil into the funnel until oil comes out of the side of the pump head; this will fill the oil line, canister filter, and pump head with oil.
ATTENTION: NEVER run the pump head dry (i.e. without oil in the pump head); doing so will severely damage the pump.
4. Apply Permatex #2 non-hardening gasket sealer to the threads of the plug (removed from the pump head). Re-install the plug and tighten.
5. Apply Permatex #2 non-hardening gasket sealer to the threads of the 1/2" brass nipple. Re-install the 1/2" brass cap on the brass nipple and tighten.
6. Open the bleeder valve on the pump two to three (2-3) full turns, and position a container to catch oil which will flow from the bleeder during pump priming.
7. Close the mini ball valve at the outlet port of the pump head
ATTENTION: Verify that the relief oil line is installed back to the tank before closing the mini ball valve. Closing the mini ball valve will cause the internal pump relief valve to open.

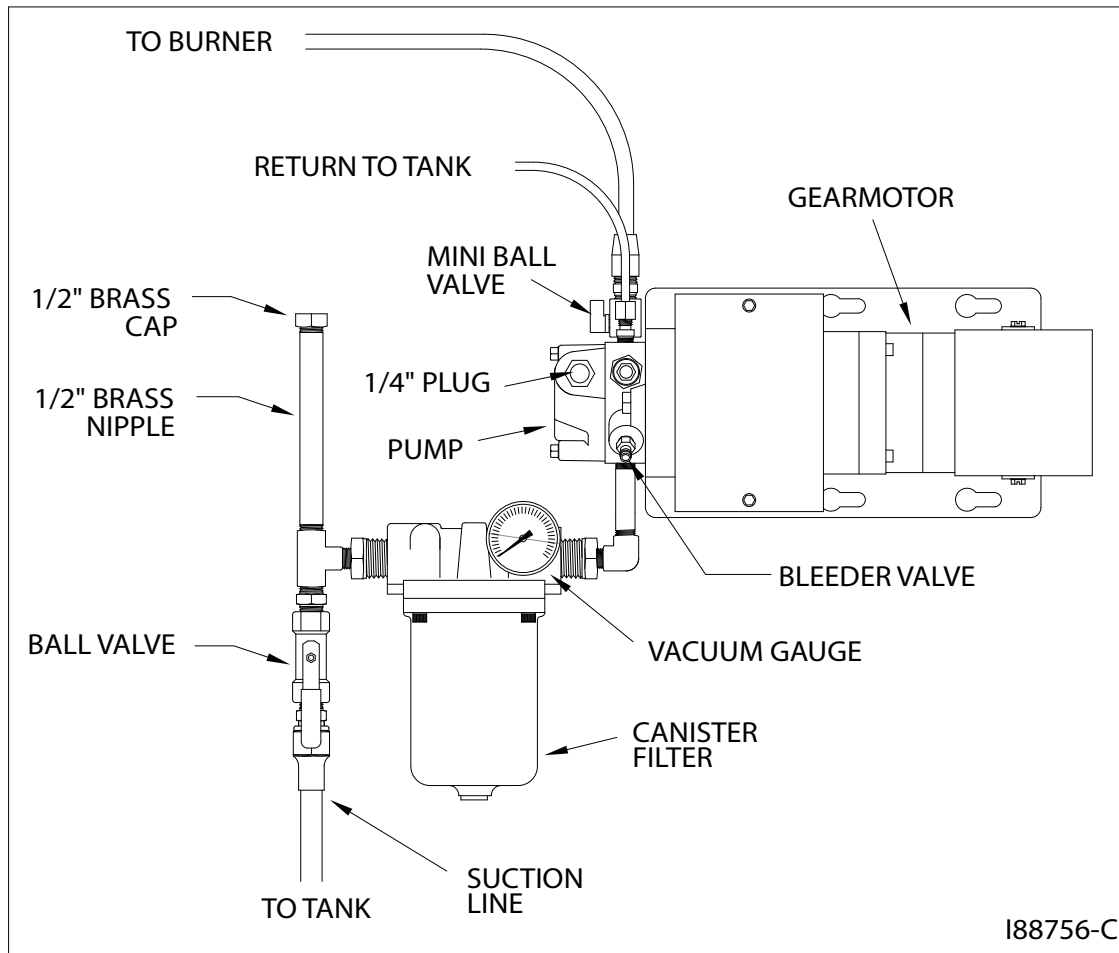

Figure 5A - Priming the Metering Pump

Priming the Metering Pump (continued)

8. Activating the Pump

NOTE: The CB-3500 and CB-5000 furnaces feature a priming switch which is mounted on the left-hand side of the electrical junction box on the front of the furnace cabinet. The priming switch has two positions:

- **PRIME (switch is in the UP position / orange indicator light is ON):** this is used only for pump priming. When the switch is in the UP position, the pump circuit is activated for priming. The pump will continue to run as long as the switch is in this position. The oil primary control circuit is de-activated so the burner cannot run while the switch is in the UP position.
- **BURNER (switch is in the DOWN position):** this is used for normal burner operation. When the switch is in the DOWN position, the burner controls the operation of the pump. The pump will only run while the burner is running.

- a. Refer to Figure 5B to locate the priming switch.
- b. Turn the priming switch to the prime (UP) position. The pump should immediately start running.

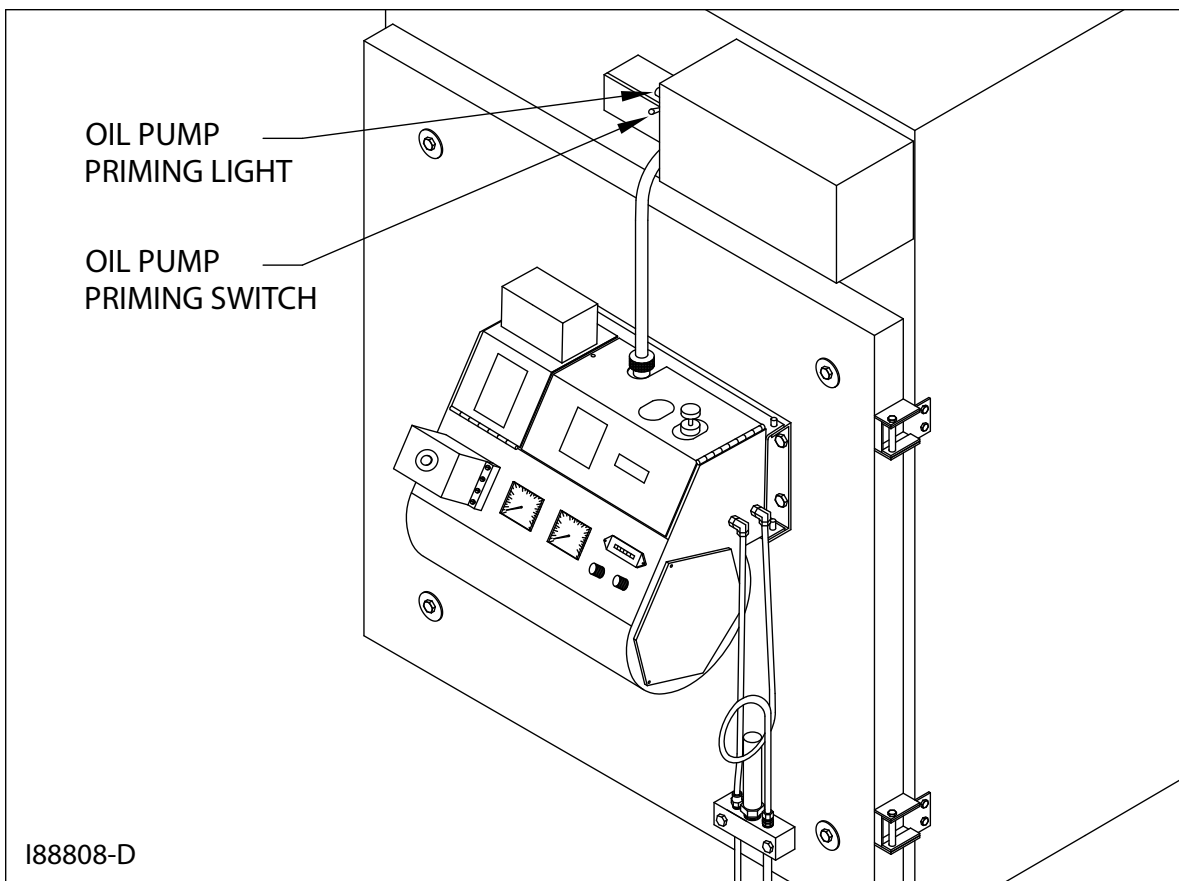

Figure 5B - Locating the Pump Priming Switch

Priming the Metering Pump (continued)

9. Run the pump until a solid stream of oil flows from the pump bleeder. This will bleed all air out of the suction line, oil filter and pump head.
ATTENTION: For the metering pump to operate correctly, it is very important that the system is entirely full of oil and all air is bled out. The burner will shut down if there is any air in the system.
 10. Open the mini ball valve at the outlet port of the pump head to allow the pressure oil line to be filled.
 11. Close and tighten the bleeder on the pump.
 12. Turn the priming switch to the burner (DOWN) position so that the pump stops running.
 13. Disconnect the pressure oil line from the burner and position a container to catch oil which will flow from the pressure oil line during pump priming.
 14. Turn the priming switch to the prime (UP) position. The pump should start running immediately .
 15. Run the oil pump until the proper flow of oil has been established, and the oil line has been completely flushed out.
 16. Turn the priming switch to the burner (DOWN) position so that the pump stops running.
 17. Re-connect the oil line to the burner.
-

Vacuum Testing the Oil Pump

Vacuum testing the oil pump is a very accurate way to determine the following:

- The condition of the pump -- the ability of the pump to pull a vacuum and suck oil from the tank.
- The condition of the fittings, gaskets and seals from the ball valve to the pump -- these components must all be airtight to avoid suction leaks.

The following procedure provides instructions for vacuum testing the pump and canister filter on systems equipped with a ball valve.

ATTENTION: For the pump to pull and hold vacuum, it is critical that all fittings are airtight. If any of these fittings are loose, the pump may not pull a vacuum or may lose the vacuum rapidly. It is also critical that all fittings in the suction line, including fittings on the canister filter, are 100% airtight.

1. Follow the instructions to prime the pump (previous procedure).
NOTE: The pump will not pull a vacuum if the pump is dry. There must be oil in the gears of the pump before the pump can pull a vacuum.
2. With the pump running, open the bleeder two to three full turns, and make sure that oil is flowing from the bleeder. **DO NOT** close the bleeder yet.
3. Refer to Figure 5A. Close the ball valve at the inlet to the canister filter. Observe the vacuum gauge.
NOTE: The ball valve must have a stainless steel ball and should be pressure tested by the manufacturer to ensure that it does not leak. If the ball valve leaks, the vacuum test will not be accurate.
4. The vacuum should increase within 30 seconds to 15 inches of vacuum. When the vacuum gauge reads 5 inches of vacuum, first close and tighten the bleeder, then turn the pump off and close the mini ball valve at the outlet port of the pump. Observe the vacuum gauge.
NOTE: If the pump will not pull at least 15 inches of vacuum, there is a very serious suction leak, or the pump is damaged.

Vacuum Testing the Oil Pump (continued)

5. If there are no suction leaks, the system will hold vacuum.
NOTE: It is acceptable for the vacuum to drop one to five inches within one minute as the seal in the pump seats. The vacuum should then hold steady for 15 minutes.

ATTENTION: If the vacuum drops *more than one to five inches within the first minute*, there is one or more leaks somewhere between the pump and the ball valve. Do the following:

- Wipe your finger along the cylinder at the shaft of the pump. If there is oil here, the pump seal is damaged. Replace the pump.
 - Disassemble and clean all the fittings from the pump to the ball valve. Properly seal all fittings with Permatex #2 non-hardening gasket sealer or equivalent. Check the condition of the o-ring on the canister filter and tighten the four canister filter bolts in a crisscross pattern.
 - Repeat the procedure to vacuum test the system to ensure that the system is air tight.
6. Follow the instructions to prime the metering pump after a vacuum test has been performed.

SECTION 6: STARTING AND ADJUSTING THE BURNER

Understanding Burner Startup and Adjustment

Starting and adjusting the burner involves a series of separate procedures which must be accomplished in sequence without interruption. Review all the procedures before attempting burner startup and adjustment, paying careful attention to safety information statements.

Preparing the Burner for Startup

1. Turn the switch on the wall thermostat OFF.
NOTE: If your thermostat does not have an OFF setting, disconnect one thermostat wire so the burner will not run.
2. Turn the main power to the furnace ON.
3. Wait at least 15 minutes until the preheater block is thoroughly warmed up. (Feel the back of the burner box to make sure the preheater is sufficiently warm. The proving switch on the preheater block will not allow the burner to start until the block is hot.)
NOTE: The preheater block will remain warm as long as power is supplied to the burner. If the main power supply is ever turned OFF, you must wait at least 15 minutes until the preheater block is thoroughly warm before starting the burner.
4. Refer to Figure 6A or 6B (depending on your burner model) to locate the air regulator. Loosen the locking nut on the air regulator.
5. Turn the adjustment knob on the air regulator counterclockwise until 1/2" of the threads on the knob are exposed. **DO NOT** back the knob all the way out.
NOTE: The air gauge will not show any pressure until the burner starts. Before starting the burner for the first time, it is very important to turn the air regulator completely OFF as described.

(continued on next page)

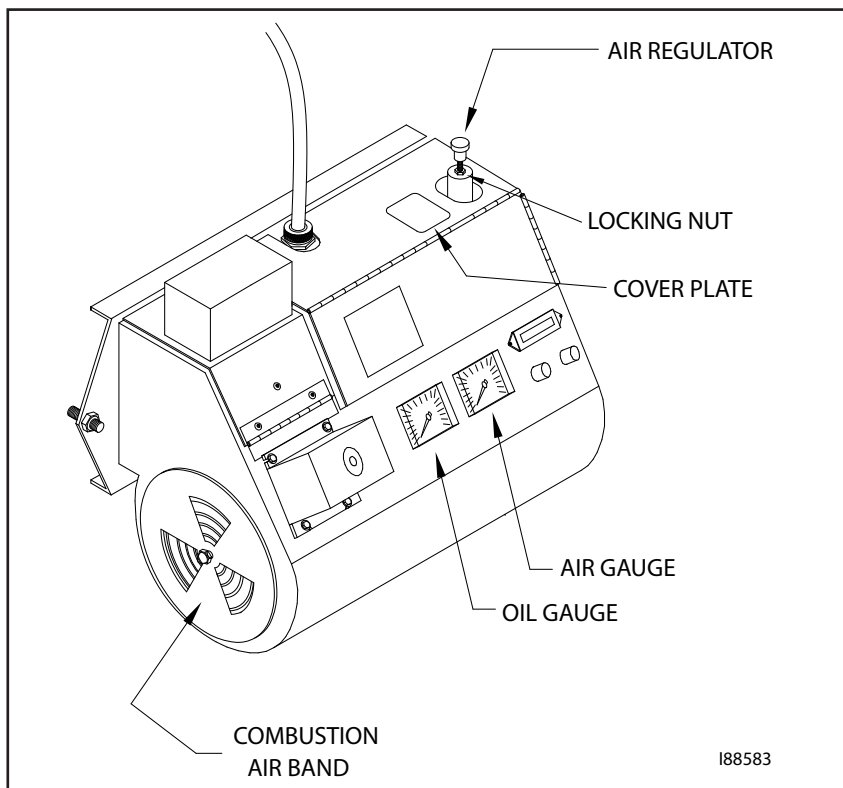

Figure 6A - Component Detail of the CB-525-S2 Burner for CB-3500 Furnaces

Preparing the Burner for Startup (continued)

6. Initial Adjustment of the Combustion Air Band for CB-3500 Furnaces:



WARNING: The combustion air band must be properly adjusted to ensure that the burner ignites and burns correctly. DO NOT attempt to start the burner with the combustion air band wide open or completely closed. Failure to heed this warning may result in fire or explosion hazard.

- Refer to **Figure 6A** to locate the combustion air band. Note that the CB-525-S2 burner has an adjustable combustion air band.
- Rotate the combustion air band to adjust it to the appropriate slot opening as listed in the **Initial Adjustment Charts** on the next page. Use a ruler to accurately set the slot opening at the widest section of the slot.

7. Initial Adjustment of the Air Intake for CB-5000 Furnaces:



WARNING: The air intake must be properly adjusted to ensure that the burner ignites and burns correctly. DO NOT attempt to start the burner with the air intake wide open or completely closed. Failure to heed this warning may result in fire or explosion hazard.

- Refer to **Figure 6B** to locate the air intake. Note that the CB-550-S2 burner has an adjustable air intake with a locking wing nut.
- Loosen the wing nut and OPEN the air intake by rotating the disk (CCW) to the appropriate slot opening as listed in the following **Initial Adjustment Charts** on the next page.
- Tighten the wing nut to lock the air intake in place.

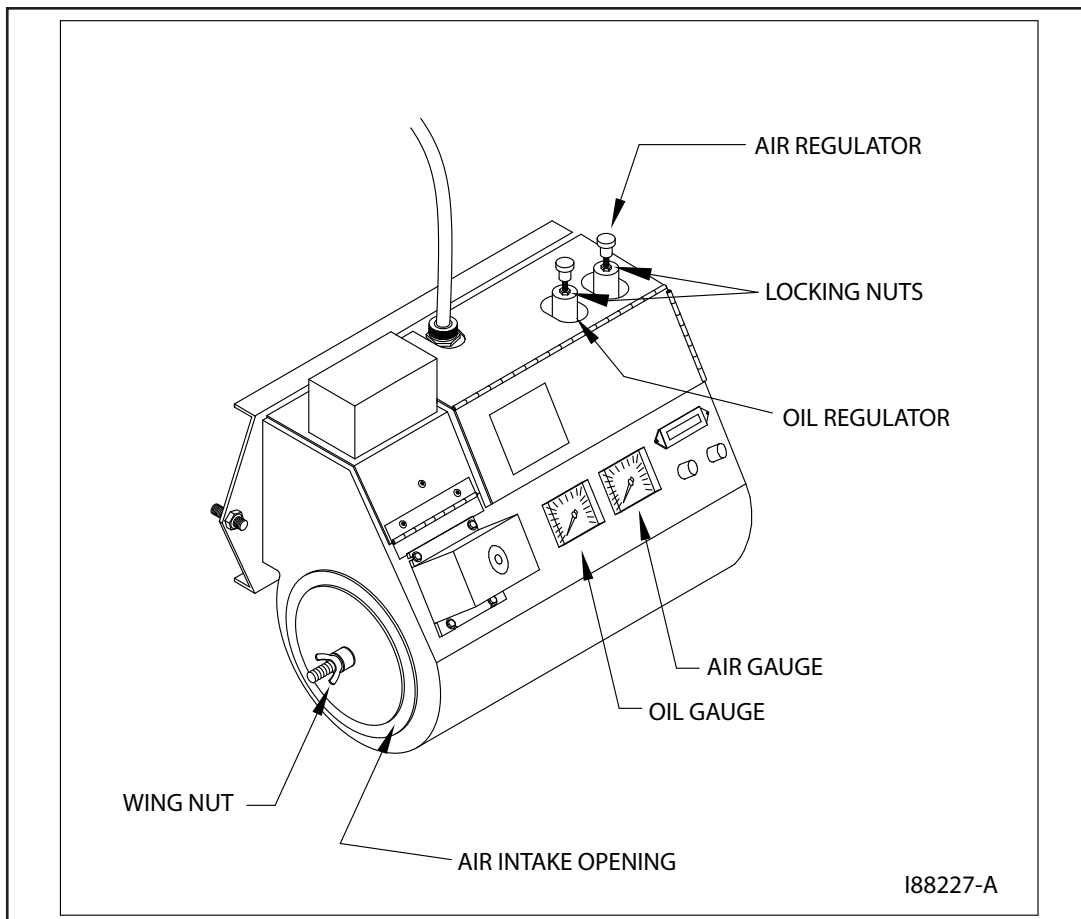

Figure 6B - Component Detail of the CB-550-S2 Burner for CB-5000 Furnaces

Preparing the Burner for Startup (continued)

ATTENTION: The settings shown in the charts below are only *initial* adjustments. *Final adjustments must be done by inspecting the flame length according to the illustrations provided on the following page.*

NOTE: The oil pressure is automatically adjusted by the metering pump.

Initial Adjustments for CB-3500

Maximum Input = 350,000 BTUH @ 2.5 GPH with CB525-S2 Burner

Oil Type	Oil PSI / Flame Length	Air PSI	Air Band	Nozzle
#2 Fuel Oil*	6.5 & <i>check flame length</i>	12-18	3/4"	9-5
#4 and #5 Fuel Oils	6.5 & <i>check flame length</i>	12-18	3/4"	9-5
Used Crankcase Oil	7.0 & <i>check flame length</i>	12-18	3/4"	9-5
Used ATF	7.0 & <i>check flame length</i>	12-18	3/4"	9-5
Used Hydraulic Oil	7.0 & <i>check flame length</i>	12-18	3/4"	9-5

Initial Adjustments for CB-5000

Maximum Input = 500,000 BTUH @ 3.6 GPH with CB550-S2 Burner

Oil Type	Oil PSI / Flame Length	Air PSI	Air Band	Nozzle
#2 Fuel Oil*	3.5 & <i>check flame length</i>	12-18	1/4"	9-11
#4 and #5 Fuel Oils	3.5 & <i>check flame length</i>	12-18	1/4"	9-11
Used Crankcase Oil	3.8 & <i>check flame length</i>	12-18	1/4"	9-11
Used ATF	3.8 & <i>check flame length</i>	12-18	1/4"	9-11
Used Hydraulic Oil	3.8 & <i>check flame length</i>	12-18	1/4"	9-11

*If you are burning light viscosity oils such as #2 fuel oil, it may be necessary to install a smaller nozzle. Call your Clean Burn dealer for more information.

Starting the Burner

- Adjust the thermostat setting above room temperature to start the burner.
NOTE: If the burner refuses to start, review the *Preparing the Burner for Startup* procedure. If, after repeating this procedure, the burner still refuses to start, check the following system components for proper functioning:
 - Verify that the red wire as shown in the **Burner Wiring Diagram** (Appendix B) is energized to 115VAC.
 - Verify that the prime switch (on the control box) is set to RUN (i.e. DOWN position).
- Adjusting the Air Regulator:**
 As soon as the burner starts running, turn the knob on the air regulator clockwise to achieve proper operating air pressure. Refer to the **Initial Adjustment Charts**.
NOTE: If the safety reset on the primary control is activated and the burner stops running, see Section 7 for further instructions on restarting your burner.

(Starting the Burner procedure continued on the next page)

Starting the Burner (continued)

3. Observing the Flame Length:

Visually inspect the flame length through the observation port. Refer to Figure 6C for an illustration of the desired flame length. The flame should extend no more than one-half of the way down the combustion chamber.

WARNING: The observation port gets hot as the burner fires. To avoid personal injury, always wear heavy work gloves and safety glasses when opening the port and viewing the flame.

CAUTION
WHEN OPENING INSPECTION PORT

**PORT MAY BE HOT
PROTECT HANDS
WEAR SAFETY GOGGLES
KEEP FACE AWAY
OPEN PORT SLOWLY**

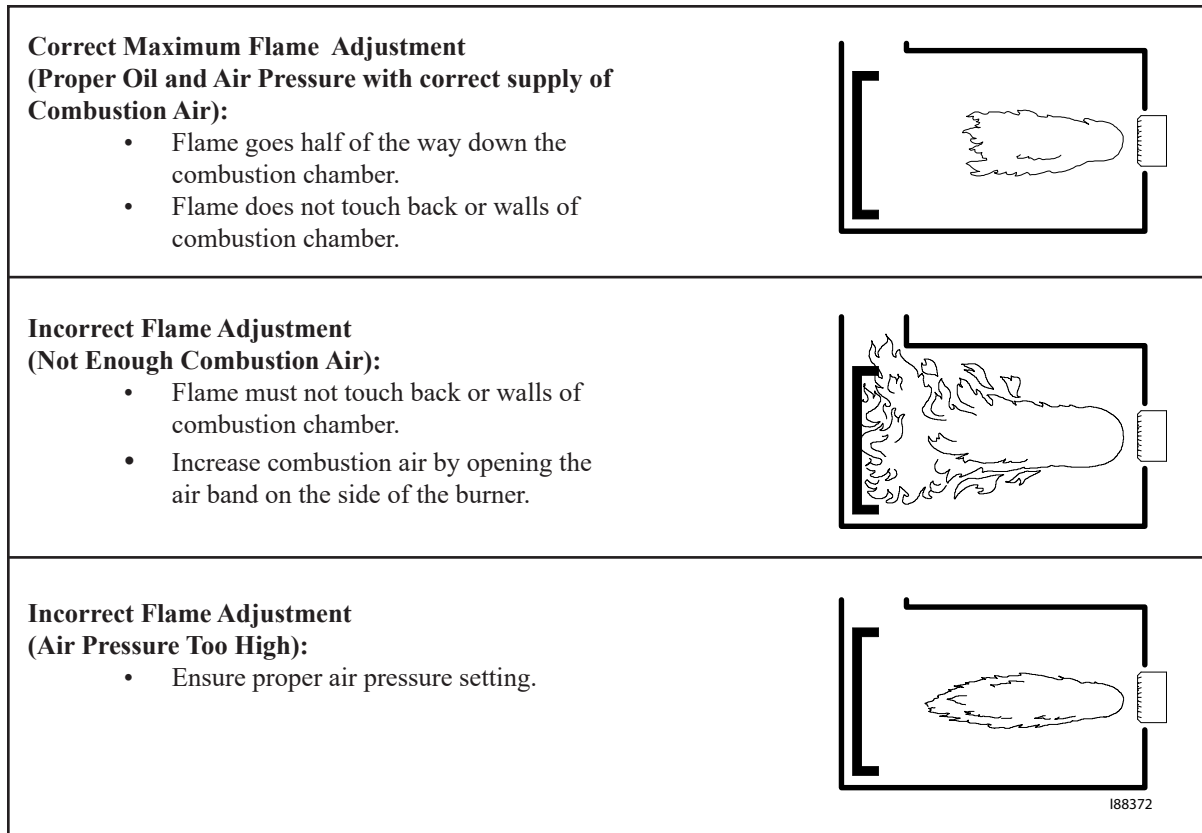

Figure 6C - Flame Length Adjustment

4. Check the flame length after the burner has fired for 15 minutes.

5. Tighten the locking nuts on the air regulator.

6. Fine Tuning the Combustion Air Band for CB-3500 Furnaces:

NOTE: The initial setting of the combustion air band may require additional adjustment.

- Refer to Figure 6A to identify the combustion air band location on the burner.
- Observe the flame. The flame should be yellow-white with sharp tips and no "sparkles."
- If the flame is orange in color or the flame length is too long, the oil you are burning requires MORE combustion air. OPEN the air band 1/8" to 1/4", and re-check the flame for the proper characteristics.
- Re-check the flame after five minutes. You should see a yellow-white flame with sharp tips and no "sparkles", and the flame should extend half of the way down the combustion chamber.

Starting the Burner (continued)

7. Fine Tuning the Air Intake for CB-5000 Furnaces:

- Refer to Figure 6B to identify the air intake location on the burner.
- Observe the flame.
- If you see "sparkles" in the flame, or the flame is orange in color, the oil you are burning requires MORE combustion air. Rotate the locking tab DOWN and OPEN the air intake 1/16" to 1/8", and re-check the flame--you should see a yellow-white flame with no "sparkles."
- Re-check the flame after five minutes--the flame should still be yellow-white with no "sparkles."
- Rotate the locking tab UP to lock the air intake in place.

8. Checking for a Smokeless Burn:

Check for a smokeless burn by observing the stack while the burner is running. If you see any smoke, repeat the previous steps for setting the combustion air band or air intake and adjusting the air regulator. After adjusting the combustion air band or air intake, re-check the flame length.

NOTE: Check for a smokeless burn periodically (as you do the flame length). Immediately readjust the burner if you ever see smoke coming from the stack. Smoke indicates improper air/fuel adjustment.

NOTE: When using instruments to adjust the burner for a smokeless burn, the following readings should be achieved:

- Draft over fire should be -.02 inch w.c.
- Adjust for a smoke spot of a trace to #2
- Adjust for a CO₂ reading of 8 to 12% or an O₂ reading of 4 to 8%
- Cad cell reading of 200 to 500 ohms

Checking the Operation of the Blower Motor

NOTE: It is important to verify that the blower motor operates correctly to ensure that the fan limit control is properly cycling the blower motor as described below. Also refer to Appendix A at the back of the manual for additional information on the fan limit control.

1. Start the burner and adjust it as described previously in this section.
2. The blower motor will not start until the burner has been running for 5 to 15 minutes to heat up the combustion chamber and heat exchanger. At this point, the fan limit control will activate the blower motor.
3. Once the blower motor has activated, turn the burner off by turning the wall thermostat to OFF.
4. With the burner off, the blower motor should continue to run for 5 to 10 minutes until the combustion chamber is cooled down. The fan limit control will then shut off the blower motor.



CAUTION: If the blower motor does not operate as described, immediately shut down your furnace and contact your Clean Burn dealer.

SECTION 7: RESETTING THE FURNACE AND BURNER

(See Appendix B for additional information)

Understanding Furnace/Burner Shutdowns

When troubleshooting furnace/burner shutdown situations, Clean Burn recommends the following sequence of actions:

- Follow the procedure for Resetting the Oil Primary Control provided in this section.
- If the burner will not restart, review the information provided in this section on the functioning of the Fan Switches and the Hi-Temp Limit Switches.
- If the burner still will not restart, contact your Clean Burn Distributor for immediate service.

The Oil Primary Control

The oil primary control will go into safety lockout and shut the burner off when it detects flame-out during burner operation. The following procedure explains what should be done when this occurs.

It is very important that you follow these instructions precisely when resetting the safety on the primary control and restarting the burner.

Resetting the Oil Primary Control



DANGER! DO NOT push the reset button more than once! DO NOT push the reset button if oil mist is present in the combustion chamber or when the combustion chamber is hot! DO NOT operate your furnace if excess oil, oil vapor or fumes have accumulated in or near your furnace. As with any oil burning furnace, improper operation may result in a fire or explosion hazard.

1. Refer to Figure 7A.
2. Check the combustion chamber for fuel mist by shining a flashlight through the observation port. If you see fog (fuel mist) in the chamber, DO NOT push the reset button.
3. If the combustion chamber is hot, allow the furnace to cool for at least 30 minutes. DO NOT push the reset button.
4. When you are sure all mist has been cleared from the chamber and the combustion chamber is cool, depress the red button on the primary control for 2 seconds, then release. Reset the control ONCE ONLY.
5. If the burner will not restart, call your Clean Burn dealer immediately.

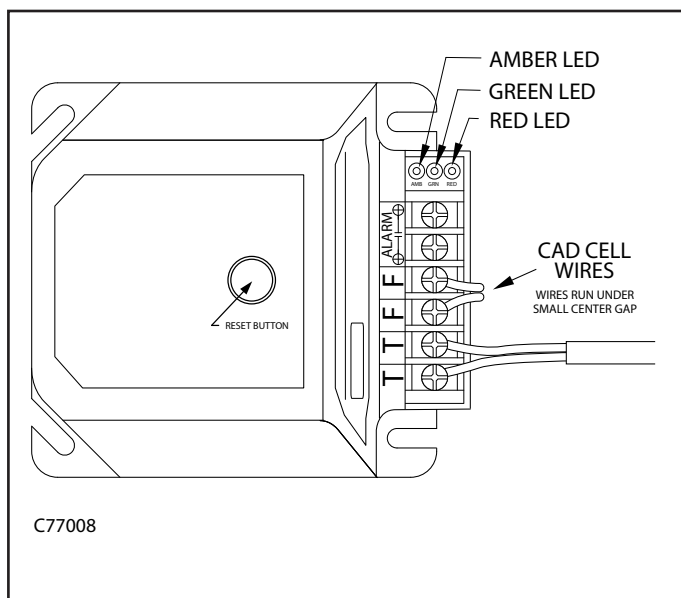

Figure 7A - Oil Primary Control

	WARNING
	<p>Fire and explosion hazard. Do NOT press reset button until you read and understand Reset Procedures in Operator's Manual. 42000 Rev. 2</p>

ATTENTION: *Never touch a jumper wire from an "F" terminal to a "T" terminal on the oil primary control. This will severely damage your primary control.*

Understanding the Fan Switches and Hi-Limits on the CB-3500/CB-5000 Furnaces

The CB-3500 and CB-5000 furnaces feature *redundant* fan switches and *redundant* limit switches. The two fan switches enable efficient working of the fan/blower for both unit heater and central furnace applications. The two limit switches serve to protect the furnace from damage due to overheating. Review the following specifics on each of the switches/controls to understand their operation; refer to the **Furnace Wiring Diagrams** in **Appendix B** at the back of this manual to review the installation of these switches.

The Blower/Fan Switch

The CB-3500/CB-5000 furnaces feature an F-180 blower/fan switch (normally open) which is surface-mounted at the front of the combustion chamber as shown in Figure 7B. The blower/fan switch senses the temperature of the combustion chamber as the burner is firing. When the combustion chamber reaches the proper temperature, the switch closes and sends power to the blower motor relay to turn ON the blower. When the wall thermostat is satisfied and the burner shuts off, the blower/fan continues to run until the switch senses that the combustion chamber has cooled down. The switch then opens and shuts off the blower/fan.

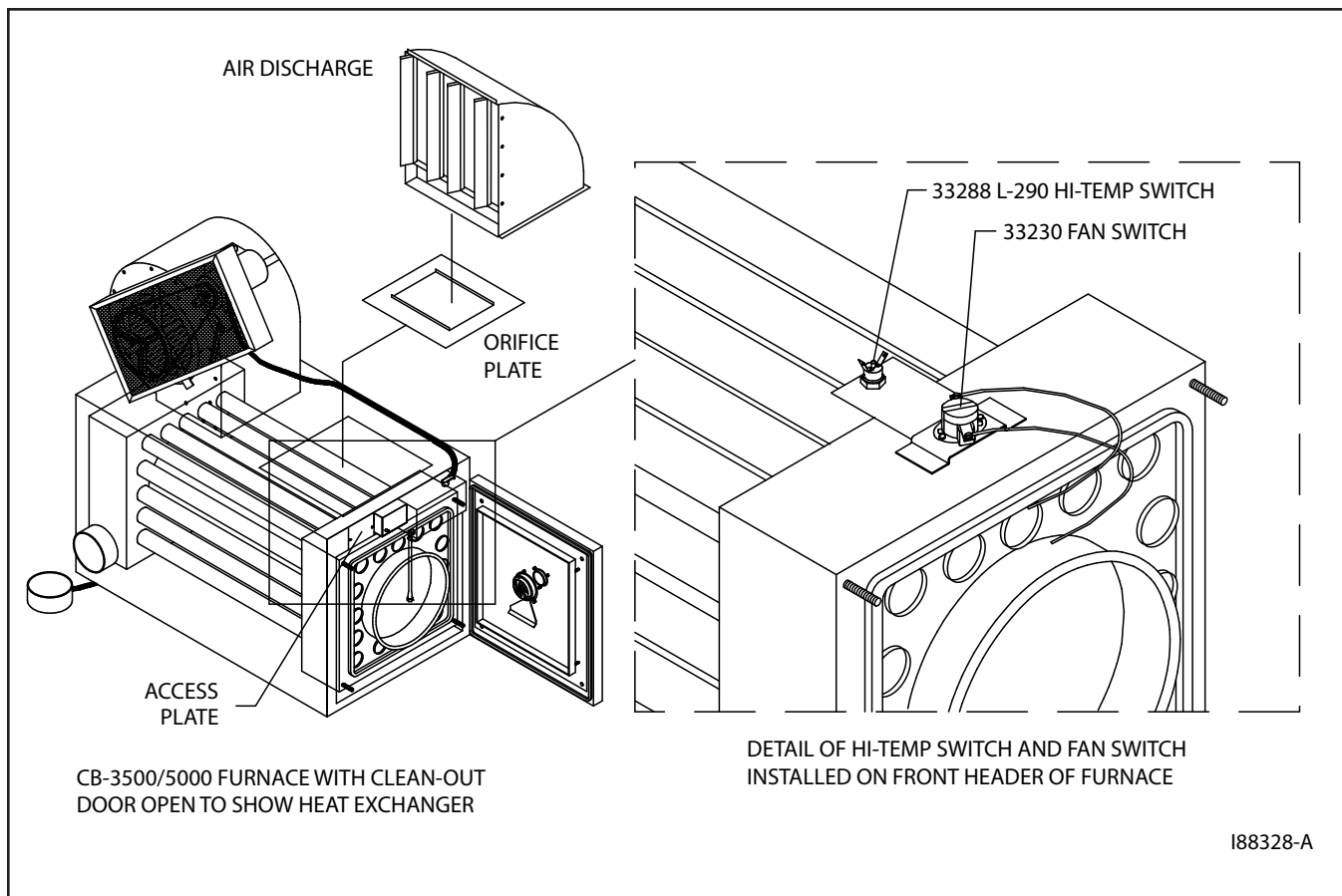

Figure 7B - Locating the F-180 Fan Switch and the L-290 Hi-Temp Limit Switch

The Fan Limit Control

Understanding the Operation of the Fan Limit Control

The fan limit control, which is a probe style control, senses air temperature within the furnace cabinet. This control contains two switches: the fan switch and the limit switch. This control is especially important for the functioning of the fan with ducted applications.

Fan Switch: The fan switch is normally open and provides power to the fan (or blower). When the fan limit control senses "Fan On" temperature, the fan switch closes and starts the fan (or blower). When the wall thermostat is satisfied and the burner shuts off, the fan continues to run until the fan limit control senses the "Fan Off" temperature. At this temperature, the fan switch opens and shuts off the fan (or blower).

NOTE: The fan limit control has a white fan switch button. Make sure the white button is pulled OUT for automatic (normal) operation. When the button is pushed in (manual setting), the fan will run continuously.

Limit Switch: The limit switch is normally closed and provides power to the oil primary control on the burner. If the fan limit control senses 200 degrees F, the limit switch opens and shuts off power to the oil primary control and the burner stops running. The fan (or blower) continues to run. Once the fan limit control senses 170 degrees F, the limit switch automatically resets and restarts the burner.

ATTENTION: It is very important to avoid cycling the burner on hi limit as described above. If the hi limit activates, immediately check and readjust burner settings.

ATTENTION: DO NOT change the fan limit settings from the specified settings, or severe damage to the furnace cabinet may occur.

Setting the Pointers on the Fan Limit Control Dial

1. Turn OFF main power to the furnace.
2. Remove the fan limit control cover.
3. While holding the dial securely in place with your thumb, move the pointer to the desired setting.

ATTENTION: *DO NOT rotate the dial when setting the pointers*; doing so will severely damage the control.

Fan Limit Control Settings: CB-3500/CB-5000

Fan Off:	100
Fan On:	120
Limit:	210

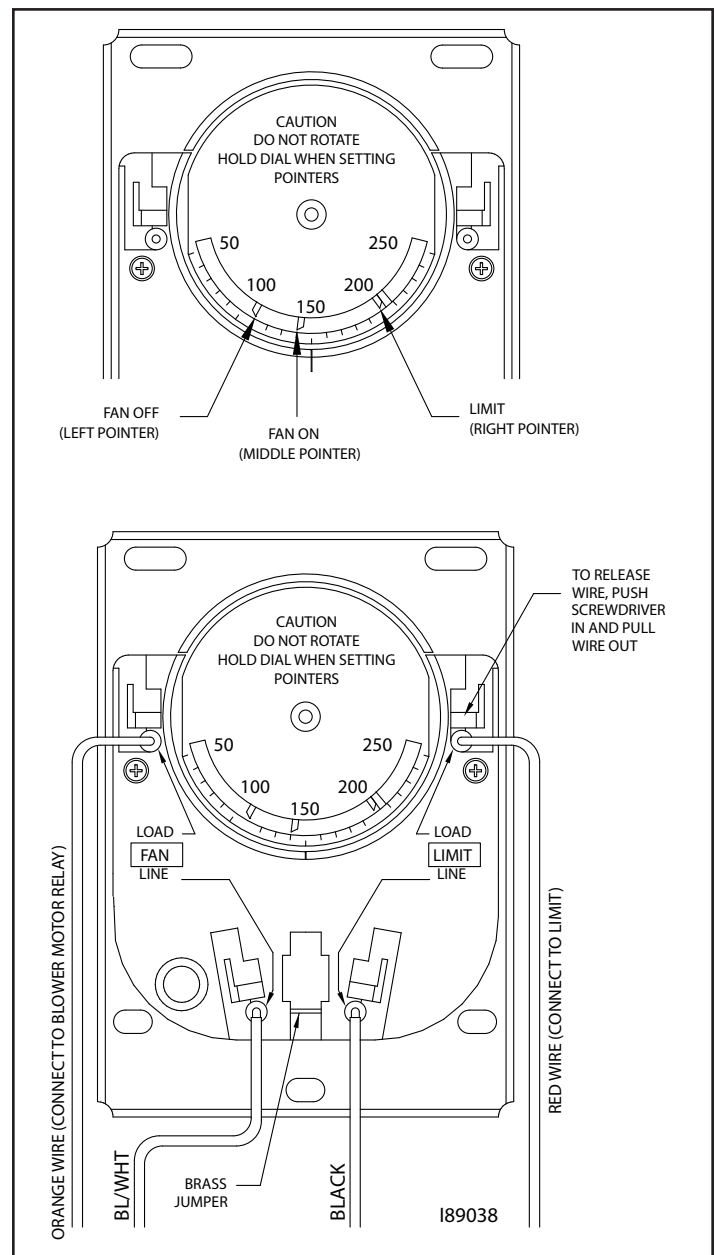

Figure 7C - Fan Limit Control Components

The Auxiliary Hi-Temp Limit Switch

The CB-3500 and CB-5000 furnaces are equipped with an auxiliary L-290 high temperature limit switch which is mounted on a bracket at the front of the combustion chamber as shown in Figure 7B. This switch senses the build-up of heat within the combustion chamber beyond the fan limit control setting and is designed to protect the furnace from damage due to overheating.

Understanding the Function of the Auxiliary L-290 Auto-Reset Hi-Temp Limit Switch

If the temperature of the combustion chamber has exceeded the range of the fan limit control, the auxiliary L-290 auto-reset hi-temp limit switch opens and shuts off power to the primary control on the burner, and the burner shuts down. After the combustion chamber has sufficiently cooled, the L-290 switch will *automatically* reset, and allow the burner to re-start.

The L-290 hi-temp limit switch will open and shut down the burner if any of the following conditions exists:

- **If the fan/blower has stopped running for any reason during furnace operation**, the heat in the furnace may cause the L-290 hi-temp limit switch to open. Ensure that the fan/blower is functioning properly.
- **The fan limit control is not functioning properly.** If the fan limit control has malfunctioned, the L-290 could cycle on/off repeatedly. If this occurs, contact your Clean Burn Distributor immediately for service.
- **The furnace is overfiring.** Review the directions in Section 6 in the Operator's Manual to properly adjust the burner.
- **Improper ductwork is installed on the furnace (*applicable only if your furnace is operating as a central furnace*).** Ductwork must be installed by qualified HVAC personnel according to industry standards and the specifications provided in Section 3 of the Operator's Manual.

ATTENTION: *It is very important to determine the reason for the opening of the L-290 switch and take steps to correct the cause; failure to do so may result in serious overheating and damage to the heat exchanger of the furnace. Additionally, if the burner is rapidly cycling on/off, contact your Clean Burn Distributor immediately; failure to address this situation may result in serious damage to the furnace.*

SECTION 8: ADJUSTING THE DRAFT OVERFIRE

Understanding the Importance of Draft

Draft in the furnace is created as the hot combustion gases rise up the stack, creating a negative pressure inside the stack and the furnace. This negative pressure is measured as inches of water column (W.C.) of draft. A proper draft overfire of $-.02$ to $-.04$ w.c. is essential so that all combustion products travel away from the burner, down the combustion chamber, through the furnace flues and up the stack.

Checking for Correct Draft Overfire



WARNING: Correct draft overfire is essential for the proper and safe operation of your furnace.

Your furnace is equipped with an observation/draft reading port to check draft overfire. *A qualified serviceman with proper equipment must check/adjust your furnace for proper draft.* Contact your Clean Burn dealer for this service.

1. Insert the probe of the draft gauge instrument into the draft reading port in the observation port as shown in Figure 8A.
NOTE: Follow the directions with the draft gauge to use your specific type of gauge.
2. Note the draft overfire reading on the draft gauge.
ATTENTION: The draft reading should be in the $-.02$ to $-.04$ w.c. range. Poor draft (i.e. $-.01$ to $+.08$) results in back pressure in the furnace and poor burner performance. Too much draft overfire (i.e. *greater than* $-.04$) sucks the heat from the furnace and results in abnormally high stack temperature.

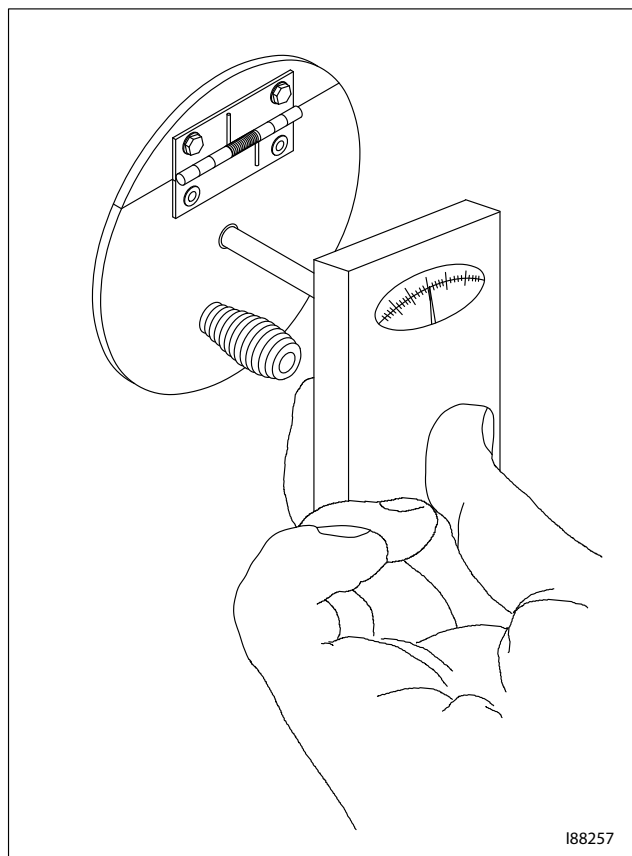

Figure 8A - Checking for Proper Draft Overfire

Adjusting the Barometric Damper

NOTE: If the draft overfire is not in the $-.02$ to $-.04$ w.c. range, it is necessary to adjust the barometric damper.

1. Before starting the burner, turn the weight on the flapper **COUNTERCLOCKWISE** until the flapper remains closed. This will provide maximum draft for the furnace.
2. Follow the directions in Section 6 to start and adjust the burner.
3. With the burner running, check the draft overfire with a draft gauge.
4. As shown in Figure 8B, adjust the weight on the flapper to obtain a consistent $-.02$ w.c. draft overfire. Turn the weight **COUNTERCLOCKWISE** to increase draft (i.e. draft increases as the flapper closes). Turn the weight **CLOCKWISE** to decrease draft (i.e. draft decreases as the flapper opens).
5. Tighten the locking nut to securely hold the weight in position.

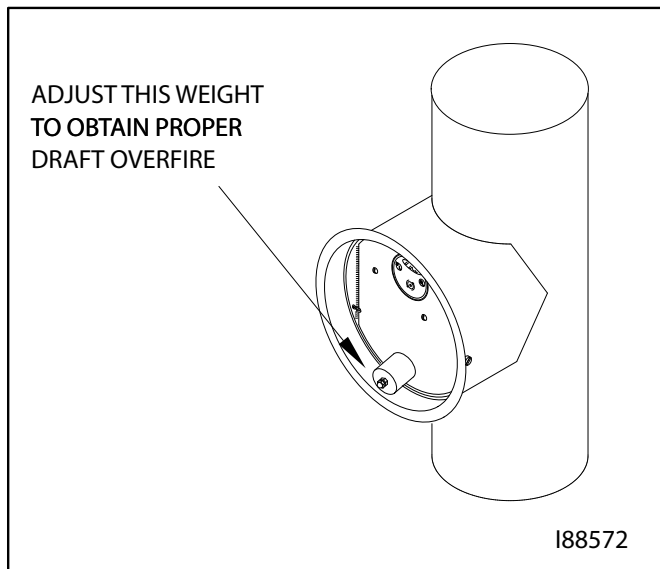

Figure 8B - Adjustment of Barometric Damper

Adjusting Draft Over Fire on Furnaces with Draft Inducers (*CB-5000 Standard; CB-3500 Optional*)

NOTE: The draft inducer is purposely sized to create a generous draft. When adjusting the barometric damper, you will find that the flapper is open most of the time. This allows the draft inducer to suck cool air through the damper to protect the inducer motor from heat damage.

1. Use a draft gauge to check draft over fire.
2. Adjust the barometric damper to obtain -0.02 w.c. draft over fire. If you still have too much draft, adjust the draft plate on the draft inducer. Move the plate in $1/4$ " to reduce the draft. Recheck the draft reading.

Solving Draft Overfire Problems



WARNING! If you cannot achieve proper draft overfire, do not operate your furnace!
Contact your Clean Burn dealer for assistance.

ATTENTION: Backdraft must be resolved or your furnace will not operate correctly!

Under backdraft conditions, draft overfire readings will show positive pressure in the combustion chamber. *Backdraft means that oil spray, combustion products, and heat are blown back against the burner. Backdraft results in oil-fouled retention heads and electrodes. Severe backdraft will force heat back against the burner and result in heat damage to the cad cell and transformer.*

Backdraft is caused by the following conditions:

- Poor draft caused by improper stack design. (See Section 4.)
- Poor draft caused by improper adjustment of the barometric damper.
- Incorrect combustion air band setting on the burner. (See Section 6.)
- Furnace flues are plugged with ash. (See Section 9.)
- Exhaust fans in your building are sucking gases down the stack.

Understanding the Effect of Exhaust Fans on Draft

Any type of exhaust fan, paint booth, or exhaust system in a building will create negative pressure in the building unless there is a source of make-up air (i.e. fresh air which enters the building and replaces the air removed by the exhaust fans.) Refer to Figure 8C on the following page.

If there is insufficient make-up air, the exhaust fan will suck air and combustion gases down the furnace stack and create backdraft in the furnace. Even if the exhaust fan is on another level of the building or in another room away from the furnace, the exhaust fan will still create backdraft at the furnace.

Checking Draft Overfire to Determine Severity of Backdraft

The following procedure is an accurate method of determining how much backdraft is created by the exhaust fans. Once this is determined, you can select the correct method for resolving the backdraft. Refer to Figure 8C on the following page as needed.

1. Turn off ALL exhaust fans and close ALL doors and windows in the building (any open door or window will allow make-up air to enter the building and will negate the test).
2. Start the furnace and adjust the barometric damper so that the draft overfire is $-.02$ w.c.
3. Check the draft overfire again. Now have someone start the exhaust fans.
4. Note how much the draft overfire has changed.

ATTENTION: If the draft overfire changed towards positive, it is mandatory that make-up air is provided to the building or severe damage to the furnace and burner will occur (voiding the warranty). If the draft overfire remained constant at $-.02$ w.c., there is sufficient make-up air entering the building, and the exhaust fan is not adversely affecting the draft.

Special Note to Service Personnel

TO ARRIVE AT PROPER DRAFT MEASUREMENTS BE SURE THAT ALL FANS WITHIN THE BUILDING ARE RUNNING WHILE ADJUSTING THE DRAFT TO FINAL LEVELS!

DRAFT OVERFIRE OF $-.02$ TO $-.04$ W.C. MEANS COMBUSTION GASES ARE FLOWING AWAY FROM THE BURNER, THROUGH THE FURNACE FLUES AND UP THE STACK

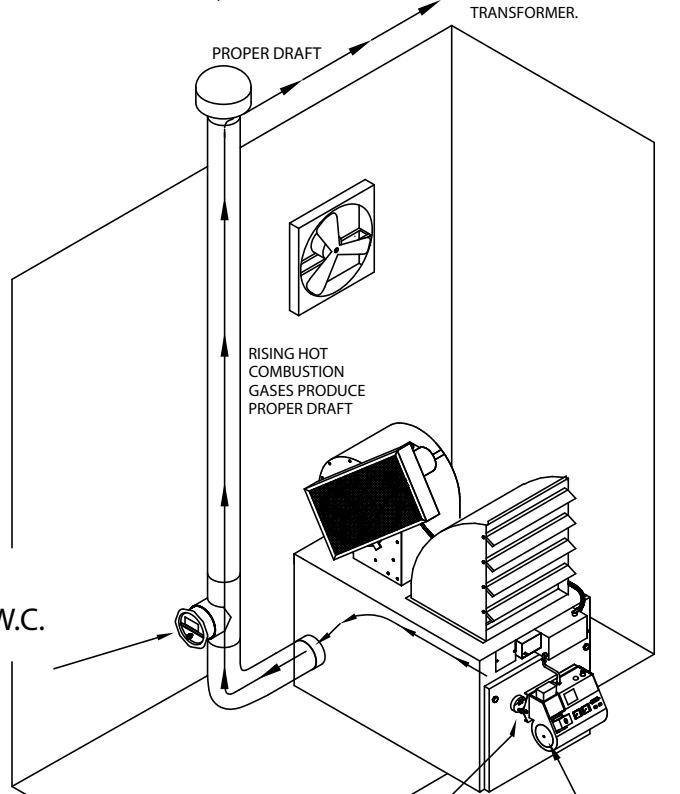
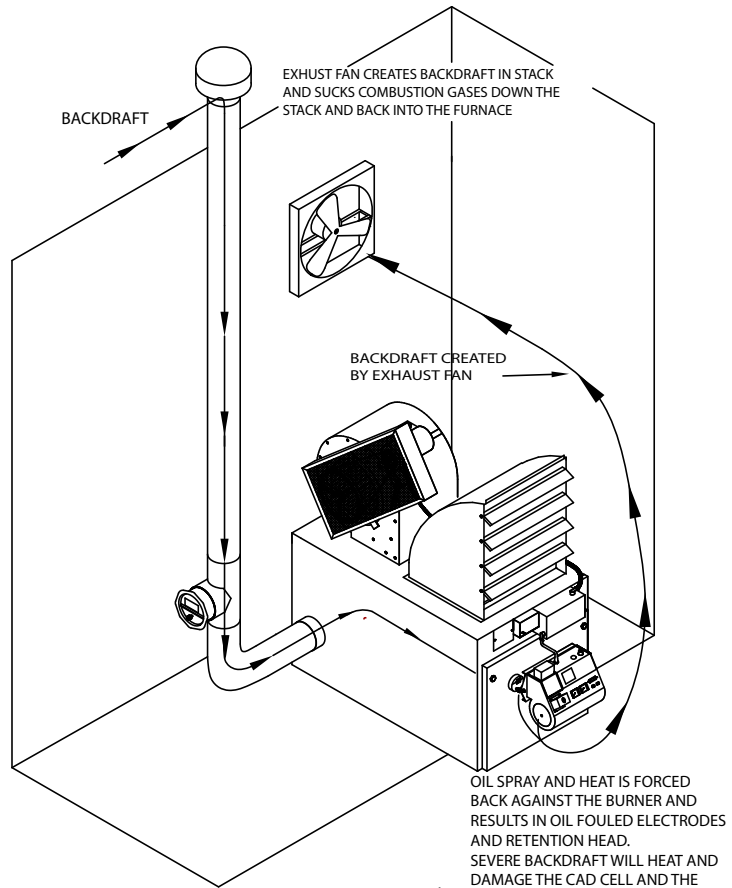

SERVICEMAN ADJUST BAROMETRIC DAMPER TO OBTAIN $-.04$ TO $-.06$ W.C. DRAFT AT STACK

Corresponding Draft Over Fire measurement should be $-.02$ to $-.04$ WC

188809-A

Figure 8C - Proper Draft vs. Backdraft

Installing a Make-up Air Louver

Exhaust Fans and Make-up Air Louvers

When exhaust fans are operated in tight buildings, there is little or no source of fresh air to replace the air removed from the building by the exhaust fan. This results in negative pressure (vacuum) in the building which creates severe backdraft problems at the furnace.

Properly sized make-up air louvers are designed to allow adequate fresh air to enter the building during operation of the exhaust fans. The louvers automatically open under the vacuum created by the exhaust fans. The louvers open just enough to provide the correct CFM of fresh air. The louvers automatically close when the exhaust fans are turned off.

Sizing the Make-up Air Louver

IMPORTANT NOTE: When using louvers and grills, and the actual free area of the louver or grill is not known, it is understood that wooden louvers/grills will have a free area of 25%, while metal louvers/grills will have a free area of 75%. ("Free area" translates into the actual space allowing air to flow through.)

- Procedure 1:**
- (a) Determine the CFM rating of the exhaust fan. This information should be stamped on a label on the exhaust fan. Make sure to add up the total CFM if more than one exhaust fan exists in the building.
 - (b) Select the correct size of make-up air louver to provide the required CFM of fresh air.

If you cannot determine the CFM rating of the exhaust fan, use the following procedure.

- Procedure 2:**
- (a) Count the total number of exhaust fans in the building.
 - (b) Close all of the doors and windows in the building *except* for one overhead garage door.
 - (c) Start the furnace and allow it to run for 15 minutes to bring it up to temperature.
 - (d) Set the draft-over-fire for $-.02''$ to $-.04''$ W.C.
 - (e) Turn ON all of the exhaust fans in the building.
 - (f) Now close the opened overhead garage door *slowly*, just until the draft gauge moves down into a positive (+) draft reading; as soon as it reaches this point, STOP the door at that position.
 - (g) Slowly open the door back up, just until the draft reading comes back up to the $-.02''$ to $-.04$ W.C.
 - (h) Measure the size of the door opening, rounding this measurement off to the *next largest even foot*.

Example of Calculations for Sizing Make-up Air Louver

Measured door opening: 12 ft. wide x 9 in. high

- Round off to 12 ft. wide x 1 ft. high
- Convert to square feet (in this case it equals 12 ft^2)
- Multiply by 1.1 correction factor ($12 \text{ ft}^2 \times 1.1 = 13.2 \text{ ft}^2$)
- Multiply by free area factor ($13.2 \text{ ft}^2 \times 1.25 = 16.5 \text{ ft}^2$)
- Refer to sizing chart (following page) - required grill size would be (1) 54 in^2 grill

Installing a Make-up Air Louver (continued)

Calculated Opening Size (square feet)	Required Louver/Grill Size (inches)
From 0.000 to 0.569	10 X 10
From 0.570 to 0.900	12 X 12
From 0.901 to 1.556	16 X 16
From 1.557 to 2.070	18 X 18
From 2.071 to 2.574	20 X 20
From 2.575 to 3.408	24 X 24
From 3.409 to 5.133	30 X 30
From 5.134 to 7.696	36 X 36
From 7.697 to 9.883	42 X 42
From 9.884 to 13.299	48 X 48
From 13.300 to 16.683	54 X 54
From 16.684 to 21.152	60 X 60

C77004

Installing the Make-up Air Louver

All louvers and grills, regardless of the material from which they are made, must be FIXED in the OPEN position OR be interlocked with the appliance so that they will open automatically during the operation of the appliance. The interlock must be placed on the driven member.

NOTE: It is very important to follow these instructions carefully to ensure proper performance of the louver.

1. The louver must not be close to the furnace. The fresh air should travel at least 40 to 50 feet before reaching the furnace, so the air warms up. The furnace will not heat well if it is receiving cold return air.
2. The louver must be high in the sidewall of the building so the cold fresh air does not blow across the floor level and chill the service personnel.
3. The louver should be installed in the opposite wall from the location of the exhaust fan. This will quickly vent diesel exhaust from the top of the building and reduce the amount of run time for the exhaust fan.

SECTION 9: MAINTENANCE

Understanding Maintenance

Servicing your Clean Burn furnace in a timely manner is very important to keep your furnace running in peak condition. Just as an automobile requires periodic maintenance such as oil changes, engine tune-ups, etc. your Clean Burn furnace also requires regularly scheduled service.



WARNING: *Failure to maintain and/or improper servicing by unqualified personnel may adversely affect the proper, safe operation of your furnace, may reduce the service life of your furnace, and may void your warranty.*

The following chart summarizes all the service intervals which are required to maintain your furnace. Service instructions/procedures for these activities are included in this chapter.

Maintenance Activity	Interval
Periodic Burner Inspection	Monthly
Cleaning the canister filter	Before vacuum gauge reads 10" HG of vacuum
Servicing the metering pump	At least once a year
Cleaning the check valve/screen	At least once a year
Cleaning water/sludge out of tank	At least once a year
Cleaning out ash	Approx. 700 hours per the burner hour meter*
Cleaning / Maintaining the Draft Inducer	At least once a year
Annual burner tune-up	At least once a year

***It is very important to clean ash from the furnace on schedule.** Normal use of the furnace requires clean-out at least twice during the heating season. Heavy, around-the-clock usage requires more frequent clean-out. For instance, *one month* of continual running of the furnace is *720 hours* (24 hours x 30 days = 720 hours).

NOTE: IMPORTANT! Record all maintenance activities in the Maintenance Record provided in the Appendixes.

Periodic Burner Inspection

Following initial start up of the burner, you should inspect the operation of the burner periodically--ideally on a monthly basis. Doing so ensures that the system is functioning efficiently and safely.

Follow these guidelines for inspecting the operation of the burner:

- Visually inspect the flame length through the observation port; the flame should extend no more than one-half of the way down the combustion chamber.
 - If the flame is diminishing or displays wide variations, clean the canister filter and check valve/screen (procedures provided in this section).
 - If the flame is firing too strongly (i.e. flame touches back and/or side walls of the combustion chamber), check the air pressure setting (see following guideline).
- Check the air pressure by observing the air gauge; proper air pressure settings are provided in Section 6. **DO NOT** overfire the burner; doing so on a continual basis will damage the furnace.
- Check the combustion air band setting for the proper opening and clean away any dust/debris as necessary. Note that the air band should **NEVER** be set fully open or closed.
- Check the draft over fire reading as specified in Section 8.

CAUTION
WHEN OPENING INSPECTION PORT

**PORT MAY BE HOT
PROTECT HANDS
WEAR SAFETY GOGGLES
KEEP FACE AWAY
OPEN PORT SLOWLY**

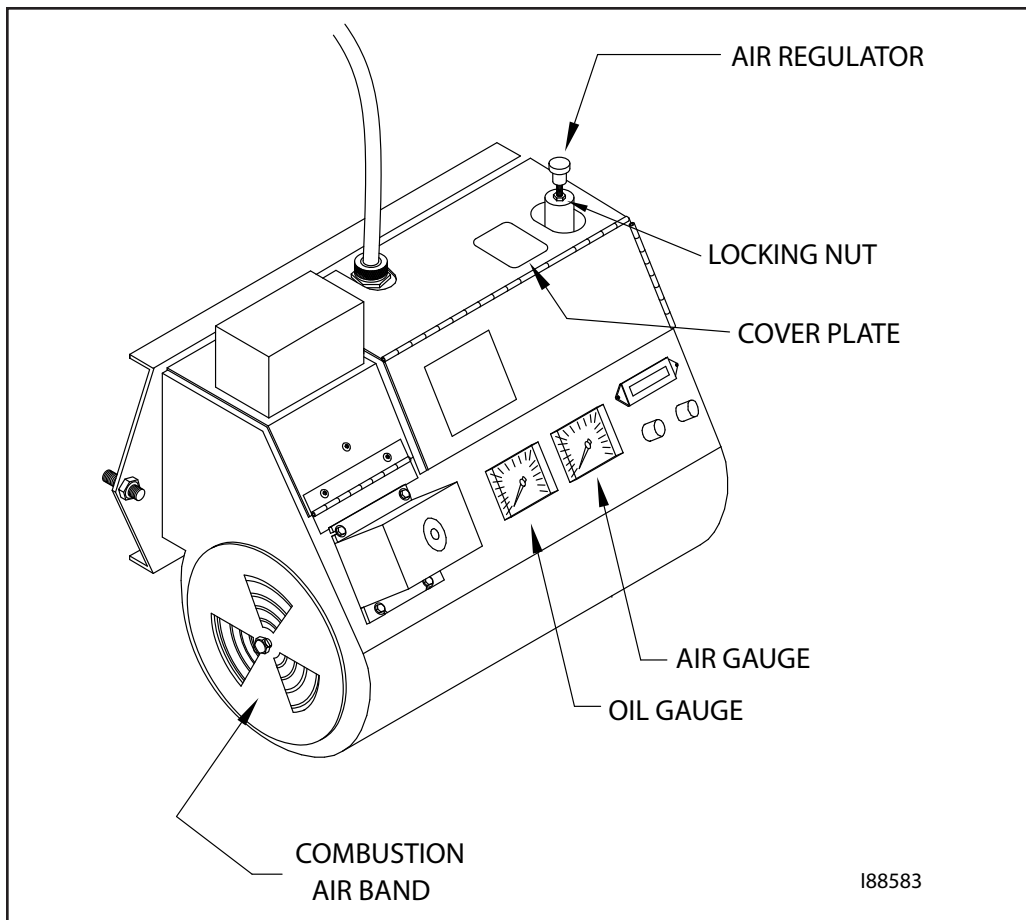

Figure 9A - Component Detail of the CB-525-S2 Burner (CB-550-S2 is similar)

Cleaning the Canister Filter

ATTENTION: Never operate your furnace with more than 10" HG of vacuum on the suction side of the pump. High vacuum separates air from the oil and results in erratic burner operation.

The following protective gear should be worn when cleaning the filter:

- Rubber gloves
- Safety goggles

1. Close the ball valve adjacent to the filter.
2. Position a container under the filter.
3. Unscrew the four bolts to drain the oil from the canister.
4. Remove the canister bowl.
5. Clean the screen and the bowl in a parts washer.
6. Referring to Figure 9B, examine the filter components as you reassemble them.
7. Check the condition of the O-rings. Replace any that are cracked or worn.
8. Ensure that the canister filter is 100% airtight by firmly tightening the four bolts.
9. Open the ball valve. Refer to Sections 5 and 6 for instructions on priming the pump and starting the burner.

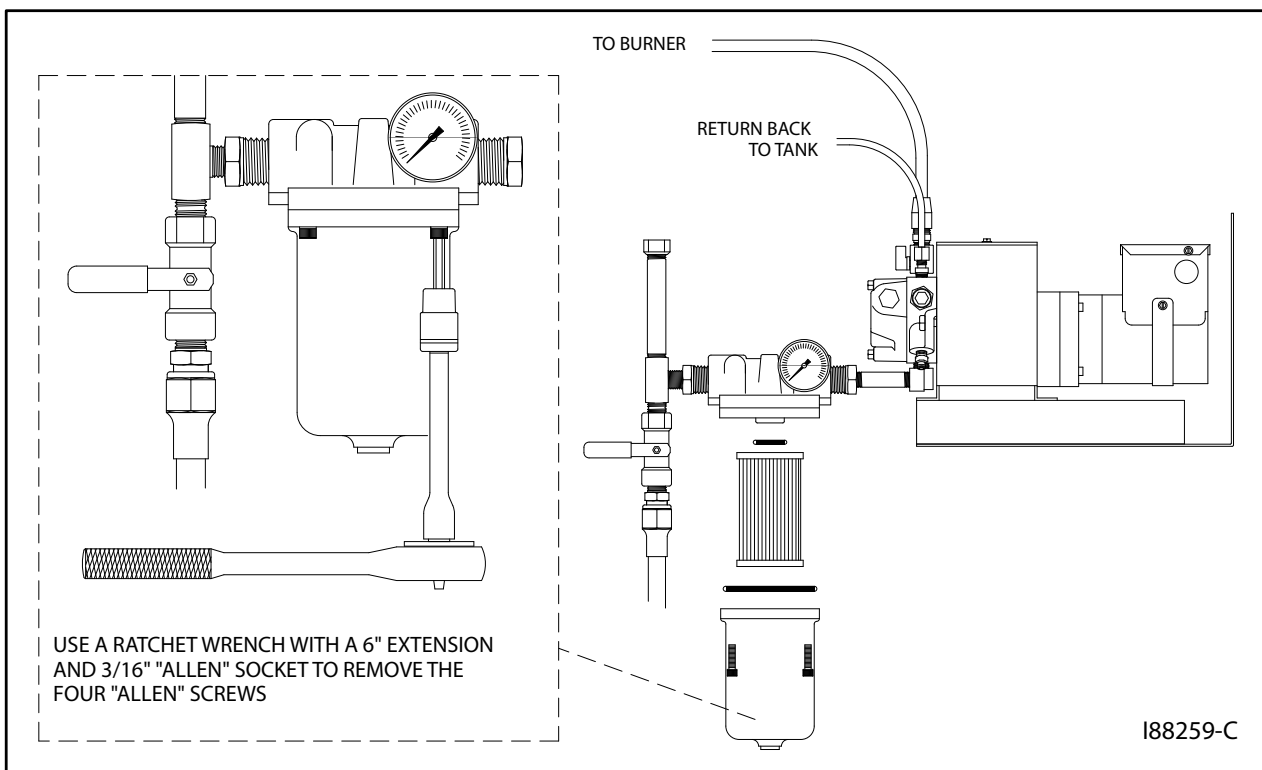

Figure 9B - Canister Filter Component Detail

Servicing the Metering Pump

1. Refer to Figure 9C.
2. Remove the pump head cover (part 1).
3. Remove the screen (part 2) and wash it.
4. Remove and discard the used gasket (part 3).
5. Install a new gasket (Clean Burn Part #32422).
6. Replace the screen and pump head cover.

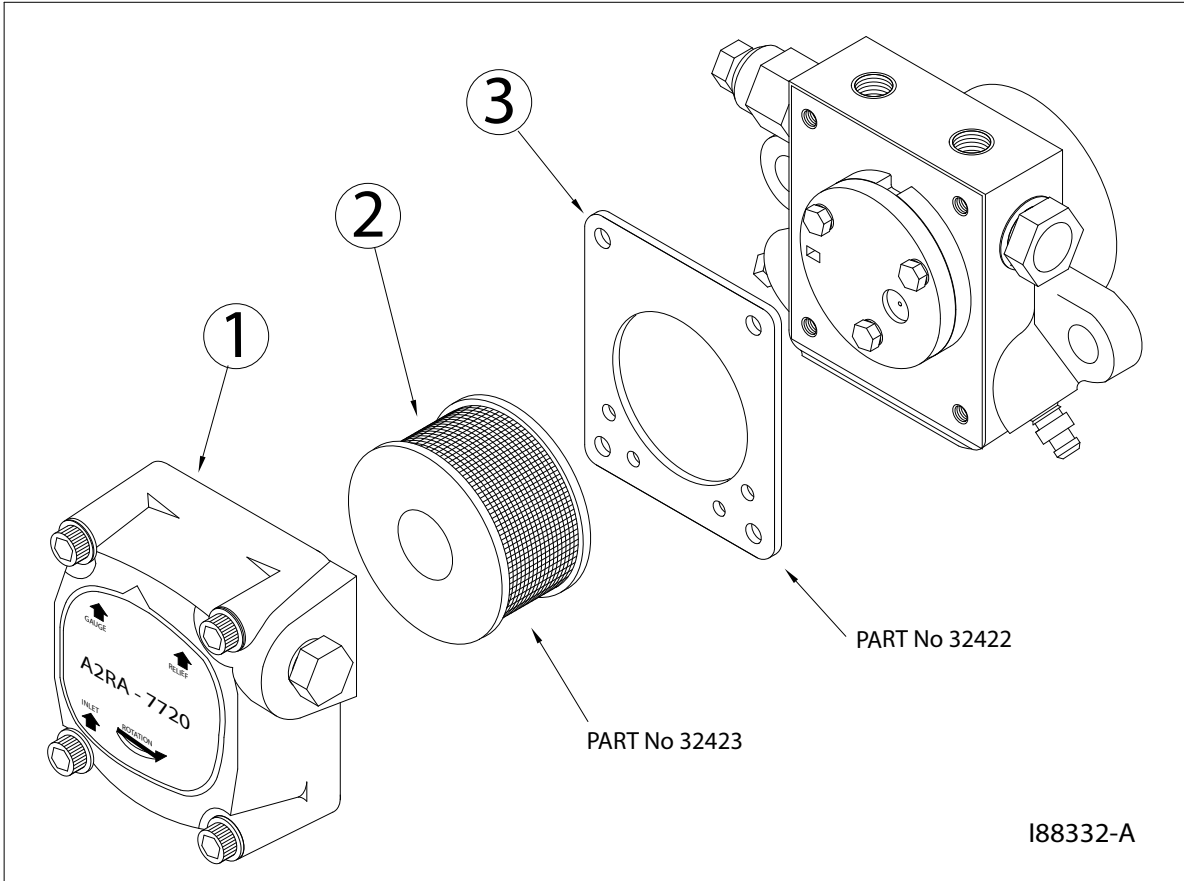

Figure 9C - Servicing the Metering Pump

Cleaning the Check Valve

This procedure applies to furnace installations with inside and outside tanks. The following protective gear should be worn when cleaning the check valve/screen:

- Rubber gloves
 - Safety goggles
1. Refer to Figure 9D. Remove the one-piece suction oil line from the tank.
 2. Remove the check valve and filter. Clean these components in a parts washer.
 3. Check the operation of the check valve. The valve must seat so it is airtight to hold pump prime.
 4. Re-assemble and re-install the components. Apply Permatex #2 non-hardening gasket sealer or equivalent to the threaded fittings. Firmly tighten all connections so the suction line is 100% airtight.
 5. Follow pump priming instructions in Section 5 to re-establish prime.

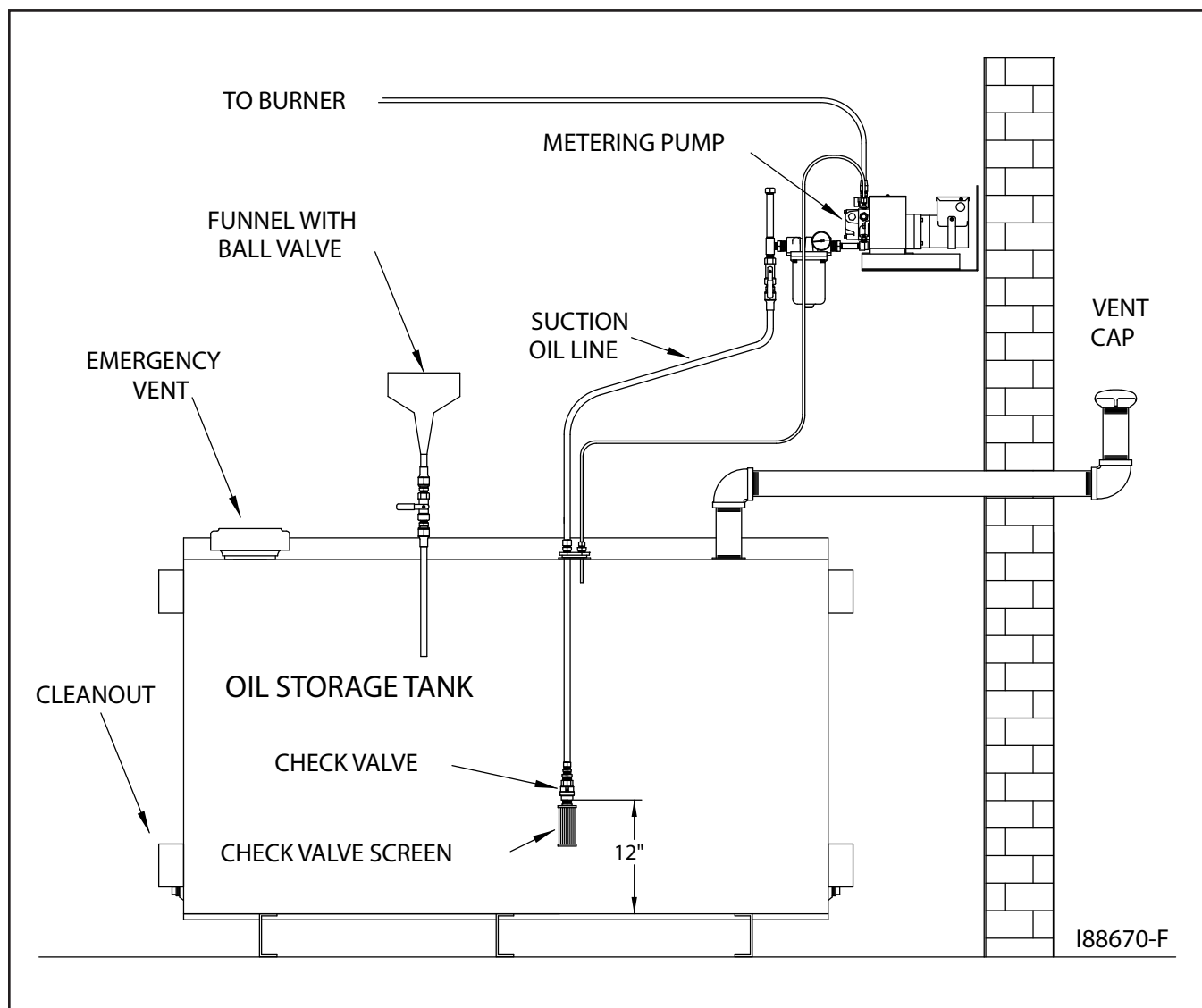

Figure 9D - Check Valve Detail

Cleaning the Tank

DO NOT allow water, sludge, or other debris to accumulate in your oil supply tank to the point that non-combustible or harmful materials are drawn into the pump or burner.

Drain water and sludge from the bottom of your tank at least once a year, and more frequently with water accumulation.

NOTE: If your used oil tank has not been cleaned on a regular basis, a considerable amount of sludge, etc. may have accumulated on the bottom of the tank. Under these circumstances, it is advisable for you to hire your used oil hauler to pump the tank. Make sure the tank is pumped to the bottom to remove all sludge, etc. from the tank (your used oil hauler may charge an additional fee for this type of service). The best time to pump the used oil tank is at the end of the heating season when the tank is low. This allows sufficient time to refill the tank with used oil (generated by your company over the summer months) so that you have adequate fuel for the heating season.

Cleaning Ash from the Furnace

NOTE: The maintenance interval for cleaning ash from the furnace is approximately 700 hours of operation as indicated on the hour meter on the burner (refer to the servicing intervals at the beginning of this chapter). **Be sure to clean the ash from your furnace at least twice during the heating season. Your furnace may require more frequent clean out of the ash due to contaminants in the oil or heavy use.** As ash accumulates, furnace heat output declines, and the stack temperature rises. 1/8" of ash has the insulating capacity of one inch of fiberglass insulation and reduces heat transfer significantly. **Never allow more than 1/4" of ash to accumulate in the combustion chamber, heat exchanger flues, or stack.**

CAUTION: Be aware that used oils may contain heavy metallic compounds or foreign materials. When burned, these compounds are deposited within the furnace, necessitating *careful* cleaning. The following protective gear should be worn when cleaning the ash:

- Respirator for fine particles (a dust mask is not acceptable)
- Rubber gloves
- Safety goggles
- Protective clothing

CAUTION: Make sure you use a sturdy ladder or scaffolding for safe access to ceiling-hung furnaces. When cleaning the furnace, static electricity may build up in the shop vac hose. If this occurs, use #12 copper wire wrapped around the hose with the other end connected to the furnace (or other ground source) to eliminate the static.

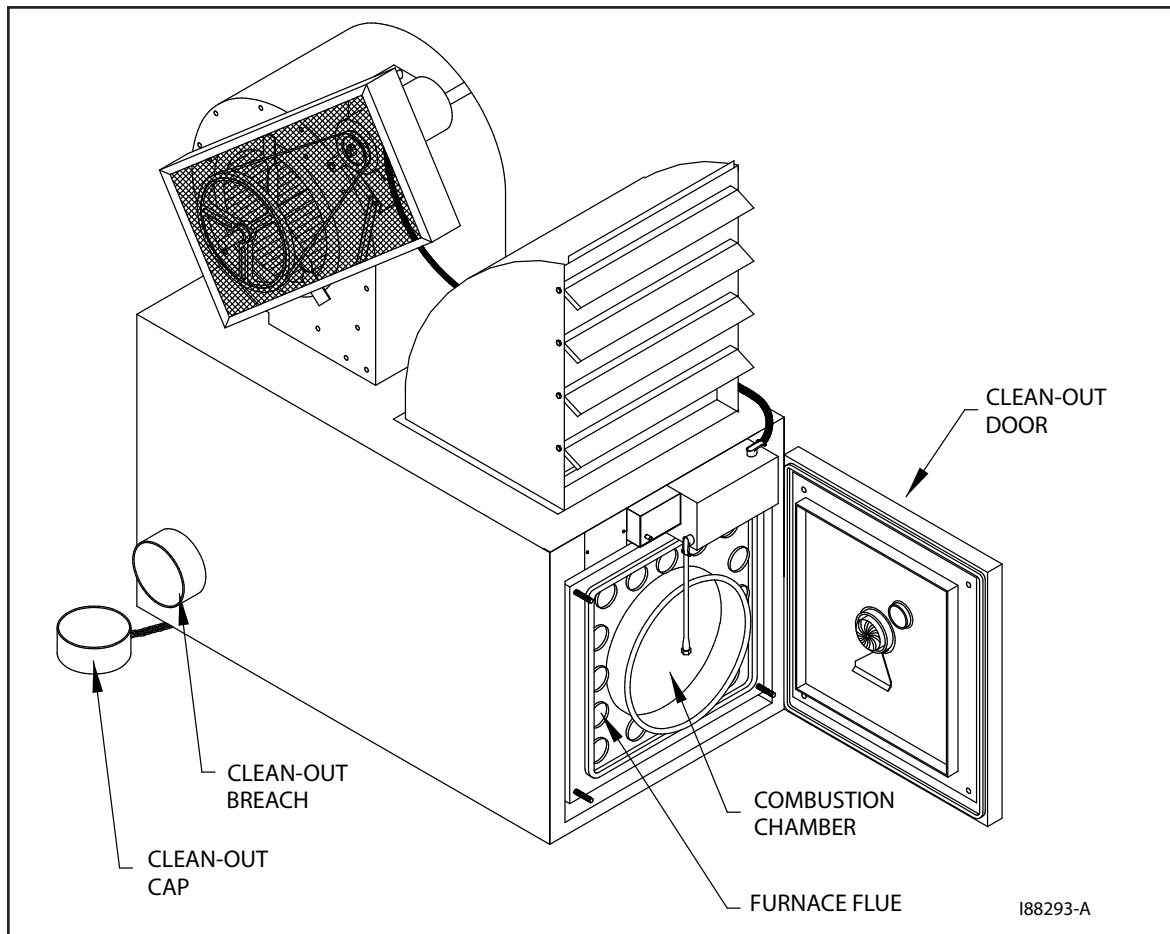

Figure 9E - Accessing the Combustion Chamber for Cleaning

Cleaning the Ash (continued)

1. Ensure that power has been turned OFF, and all "hot" components have been allowed to cool sufficiently. Carefully remove the Energy Retention Disc with a long handle or pipe. Lightly vacuum off the Energy Retention Disc.
2. Clean the ash from the stack components:
 - a. Brush accumulated ash from the stack cap.
 - b. Lightly tap the stack components to loosen the ash.
 - c. Allow ash and dust to settle in the elbow on the stack.
NOTE: It is not necessary to remove the stack to clean it. You will vacuum ash from the stack elbow as you clean out the back of the furnace as described below.
 - d. Remove the clean-out cap from the unused furnace breach.
 - e. Thoroughly vacuum out the back of the furnace, including the stack elbow, through the clean-out breach. A long wand on the hose of your shop vac is helpful in reaching all the way through the back of the furnace to the stack elbow.
3. Clean the ash from the combustion chamber (see Figure 9E):
 - a. Bleed down pressure on the air and oil lines by slightly loosening the fittings at the bottom of the connector block.
NOTE: Turn off the shut-off on the air pressure line.
 - b. With air and oil pressure completely bled off, disconnect the air and oil pressure lines from the bottom of the connector block.
NOTE: Cover the lines to keep dirt from entering the air / oil supply
 - c. Remove the lock-down nuts on the clean-out door.
 - d. Carefully swing open the clean-out door to expose the heat exchanger flues and the combustion chamber.
 - e. Check the color of the ash--it should be light gray or tan.
ATTENTION: White ash indicates excessive air pressure. Black ash or soot indicates lack of combustion air. If these conditions exist, call your Clean Burn dealer. DO NOT overfire your furnace by turning up the compressed air. Overfiring will damage the combustion chamber and heat exchanger and will void your warranty.
 - f. Vacuum the ash from the combustion chamber and the flues.
ATTENTION: When cleaning the combustion chamber, ensure that you do not gouge or damage the refractory material on the inside of the clean-out door.
NOTE: Avoid "packing" the ash in the tubes by first vacuuming the flues before pushing the flue brush down the flues. DO NOT bump or bend burner components while cleaning the combustion chamber.
 - g. Use a flue brush to thoroughly clean the flues.
 - h. Thoroughly vacuum any remaining ash residue from the flues. Make sure the back (at the breach) is still clean.
 - i. Check the flues for rust.
ATTENTION: The presence of rust in the flues indicates that chlorinated materials are being burned. Burning chlorinated materials will severely damage your heat exchanger and void your warranty. Contact your Clean Burn dealer for instructions to test your oil for chlorine contamination before firing your furnace.
 - j. Inspect the inside of the clean-out door. Make sure the refractory material on the inside of the clean-out door is in good condition and the clean-out door seals tightly when closed. If the door does not seal tightly, replace any damaged components.

Cleaning the Ash (continued)

- k. Re-install the furnace components: Swing the clean-out door shut; install and tighten the lock-down nuts so that the door seals properly. Re-install the air and oil lines on the bottom of the connector block.

NOTE: You may need to bleed air from the oil line before starting the burner. See Section 5 for the pertinent instructions.

Cleaning and Maintaining the Draft Inducer

The Draft Inducer will require periodic maintenance to ensure that the fan blades do not accumulate excessive ash which can create vibration, noise, and motor wear.

1. Ensure that power has been turned OFF, and all "hot" components have been allowed to cool sufficiently.
 2. Disconnect the wires from the draft inducer and remove it from the stack penetration.
 3. Clean the fan blades with a scraper and wire brush.
 4. Oil the draft inducer motor according to the manufacturer's recommendations.
-

Annual Burner Tune-up

Your Clean Burn furnace requires annual periodic maintenance. The burner requires an annual tune-up --similar to an automotive tune-up--to keep it running in peak condition. *The burner tune-up should be performed by a qualified Clean Burn service technician who has the necessary parts and expertise.*

Contact your local Clean Burn dealer to schedule the annual periodic maintenance which is usually (preferably) performed during warm weather to prepare the furnace for the next heating season. Various levels of service are provided to fit your particular need.

End of Season Maintenance

ATTENTION: Turn main power to your furnace OFF at the end of the heating season. This will prevent the oil from being "cooked" in the pre-heater block when it is not in use. Failure to do so may result in carbon build up in the burner preheater block which will block oil flow.

ATTENTION: Turn main power to your furnace OFF at the end of the heating season. EPA regulations allow your used oil to be burned only for "heat recovery." DO NOT operate your furnace during warm weather just to burn oil, or severe damage to the combustion chamber/heat exchanger may occur.

Contact your local Clean Burn dealer to schedule your annual burner tune-up. Allow only trained, authorized service personnel to service your burner.

SECTION 10: TROUBLESHOOTING

The following charts and tables are provided for reference in troubleshooting any difficulties encountered in furnace operation and adjustment.

- The **Flow Chart** outlines the proper sequence of events in furnace operation -- use this chart to help diagnose where a problem may be occurring.
- More specific troubleshooting information is provided in the **Troubleshooting Tables** following the flow charts. Each table lists a **Problem**, **Possible Cause**, and **Possible Action(s)** to fix the problem.

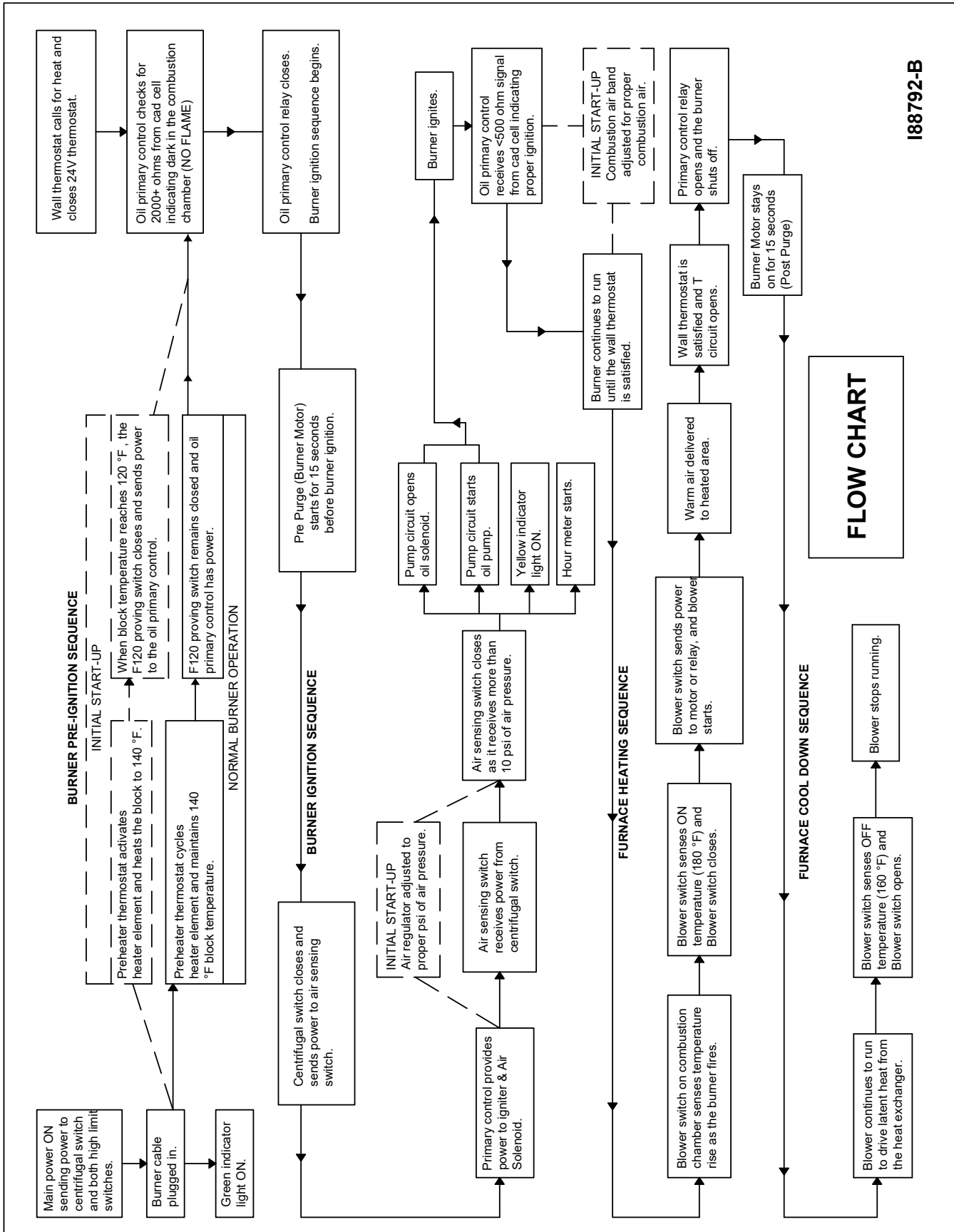

188792-B

FLOW CHART

PROBLEM	POSSIBLE CAUSE(S)	POSSIBLE ACTION(S)
<p>Burner won't run at all and Green power light is NOT ON.</p>	<ol style="list-style-type: none"> 1. Circuit breaker/main switch open. 2. Fuse/breaker blown. 3. Burner cable is damaged or not plugged in properly. 	<ol style="list-style-type: none"> 1. Close circuit breaker/switch. 2. Electrician should check out electrical system. 3. Check burner cable.
<p>Burner won't run at all and Green power light is ON.</p>	<ol style="list-style-type: none"> 1. Oil primary control has shut down on safety reset. 2. Wall thermostat is not operating. 3. Heater block is not heating up. 4. F-120 proving switch has not closed. 5. Oil primary control terminals are not wired correctly. 6. Oil primary control is damaged. 7. The L-200 or L-290 limit switches have opened. 	<ol style="list-style-type: none"> 1. Follow the directions in Section 7 to reset the oil primary control. 2. Check the wall thermostat and thermostat cable. 3. Feel the back of the burner; it should be 140 degrees F. If the heater block is NOT HOT: (a) Wait 15 minutes for the heater block to heat up and re-check the back of the burner, and (b) Check the block heater thermostat and block heater element. Refer to the wiring diagram and ladder schematic in Appendix B. 4. If the block is HOT: (a) Check the red wire at the F-120 proving switch for power. If there is NO power at the red wire, refer to the wiring diagram and ladder schematic in Appendix B to troubleshoot the circuit that provides power to the proving switch. (b) If there is power at the red wire at the proving switch, check for power at the black wire. If there is NO power at the black wire, replace the F-120 proving switch. 5. Check the oil primary control: (a) Check that the "F" terminals are NOT jumped. (b) Check that the two yellow cad cell wires are connected to the "F" terminals. (c) Check that the two thermostat wires are connected to the "T" terminals. 6. Replace oil primary control: (a) Check voltage – it must be 115 volts. 7. Test the switch for power. Note that power should be indicated on both sides of the switch. See Section 7.

PROBLEM	POSSIBLE CAUSE(S)	POSSIBLE ACTION(S)
<p>Burner ignites, but will not stay running and Burner shuts off on reset within 15 seconds.</p>	<ol style="list-style-type: none"> 1. There is a fuel delivery problem. 2. The cad cell is dirty. 3. Cad cell wires are loose. 4. Cad cell / cad cell wires are damaged. 5. The primary control is not receiving the proper ohm signal from the cad cell. 	<ol style="list-style-type: none"> 1. Follow the procedures listed in the next problem. 2. Clean and check the condition of the cad cell and cad cell wires. 3. Check that the yellow wires are connected properly at the "F" terminals on the oil primary control. 4. Replace the cad cell and cad cell wires. If the cad cell is heat damaged: (a) Clean your furnace, including the combustion chamber, flues and stack. Refer to instructions in Section 9. (b) Check for backdraft caused by exhaust fans in your building. Follow instructions in Section 8. 5. Disconnect the yellow wires from the "F" terminals. Start the burner and check the ohm reading from the cad cell. You have 10 seconds to perform this test before the burner shuts off on reset. Refer to Section 7 to reset the oil primary control. If the ohm reading is above 500 ohms: (a) Check the position of the cad cell; the cad cell must "look" straight through the central hole in the retention head. (b) Check the position of the retention head according to Appendix A
<p>Burner ignites and runs properly, but the burner shuts off on reset periodically (e.g. the burner goes off on reset during the night and requires resetting in the morning).</p>	<ol style="list-style-type: none"> 1. There is air in the suction oil line due to leaks at the fittings. 2. There is air trapped in a high point in the pressure oil line 	<ol style="list-style-type: none"> 1. Follow the procedures in Section 5 to vacuum test the pump. Reinstall and properly seal the suction line fittings to eliminate air leaks. 2. Bleed the air out of the pressure oil line.

PROBLEM	POSSIBLE CAUSE(S)	POSSIBLE ACTION(S)
<p>Burner ignites and Burner shuts off on reset sometime later during the day or night.</p>	<ol style="list-style-type: none"> 1. There is air in the fuel supply. 2. The primary control is not receiving the proper ohm signal from the cad cell. 3. There is insufficient air pressure. 4. The heater block is cold. 5. The electrodes are fouled. 	<ol style="list-style-type: none"> 1. Prime the pump. If the pump will not prime or there is air in the oil stream from the pump bleeder, follow the steps in the next problem ("Pump will not prime.") 2. Check for proper ohm signal. Follow the procedures in the previous problem (top, page 10-4) 3. Follow the instructions in Section 5 to adjust the air regulator for proper air pressure. DO NOT turn the air compressor off while the furnace is operating. If you turn the air compressor off at night, turn the wall thermostat to OFF so the burner will not run. 4. DO NOT shut off power to the furnace overnight, or the heater block will cool down, and the burner will not re-start the next morning. To turn the furnace "off" overnight, turn the wall thermostat to OFF. The heater block will stay hot. 5. If oil residues have built up on the electrodes and retention head, follow the instructions in Section 8 to check for proper draft overfire. Clean the electrodes and retention head as shown in Appendix A.

PROBLEM	POSSIBLE CAUSE(S)	POSSIBLE ACTION(S)
<p>Pump will not prime and Pump motor is running.</p>	<ol style="list-style-type: none"> 1. There is a leak(s) in the suction line. 2. The pump is not installed so it will fill with oil during the priming process. 3. The pump gears are dry. 4. The pump seal is damaged. 5. The ball valve is closed. 6. The canister filter is dirty. 7. The check valve is dirty. 8. The pump is damaged or worn out. 	<ol style="list-style-type: none"> 1. Follow the specifications in Section 4 to make sure the suction line is installed properly and that all fittings are 100% airtight. 2. Make sure the pump head is filled with oil prior to starting the pump. See Section 5. 3. Follow the procedure in Section 5 to fill the oil line and prime the pump. 4. With the pump not running, wipe your finger along the bottom of the cylinder at the pump shaft. If there is oil at the pump shaft, the seal is damaged. Replace the pump, or replace the seal. NOTE: Some oils will expand as they warm up. Because there is a check valve in the suction line, the expanding oil may build up pressure and damage the oil seal. Install a mini-accumulator in the 1/8" port of the canister filter to prevent the pressure build-up. 5. Open the ball valve on the suction line. 6. Refer to Section 9 to clean the canister filter. 7. Refer to Section 9 to clean the check valve. 8. Replace the pump

PROBLEM	POSSIBLE CAUSE(S)	POSSIBLE ACTION(S)
<p>Pump will not prime and Pump motor is NOT running.</p>	<ol style="list-style-type: none"> 1. There is NO power on the pump circuit from the burner. 2. The pump motor has shut off on thermal overload 	<ol style="list-style-type: none"> 1. Start the burner and adjust the air pressure regulator to 15 PSI. (a) If the amber "pump" light on the burner comes ON, the pump circuit on the burner has activated properly. Refer to the wiring diagram and ladder schematic in Appendix B to troubleshoot the pump circuit from the burner to the pump. (b) If the amber "pump" light on the burner does NOT come ON, there is a problem with pump circuit in the burner. With the burner running, check for power at the brown wire on the air pressure switch. If there is NO power at the brown wire, replace the burner motor. If there is power at the brown wire, replace the air sensing switch. 2. (a) The pump motor is too hot the internal thermal protection switch shut the motor off. Wait for the motor to cool down; the thermal switch will automatically reset. Check voltage and amperage draw of the pump motor. Call your dealer if the problem persists. (b) The coupling is not adjusted properly, keeping the shafts of the motor and pump from turning freely. Re-position the coupling so that both shafts turn freely. (c) The shaft on the motor or oil pump will not turn freely. If you can't turn the shafts, replace the faulty part(s).
<p>Blower motor runs all the time.</p>	<ol style="list-style-type: none"> 1. Blower motor circuit is wired incorrectly. 2. Blower relay is stuck in the closed position 	<ol style="list-style-type: none"> 1. Refer to wiring diagram and ladder schematic in Appendix B to troubleshoot the blower circuit. 2. Test the blower motor contactor. If it will not open when the power is turned OFF, replace the contactor
<p>Blower motor will not run.</p>	<ol style="list-style-type: none"> 1. The blower motor is not wired correctly. 2. The fan / blower switch is defective. 3. The blower motor has overheated and shut down on thermal reset. 4. Blower relay won't close 	<ol style="list-style-type: none"> 1. Check the fan motor wiring Refer to the wiring diagram and ladder schematic in Appendix B. Follow the directions in Section 6 to test for proper blower operation. If the blower does not operate, shut OFF power to the furnace and call your Clean Burn dealer for service. 2. Replace the fan / blower switch. 3. The blower motor is too hot – the internal thermal protection switch shut the motor off. Wait for the motor to cool down; the thermal switch will automatically reset. Check voltage and amperage draw of the blower motor. Call your dealer if the problem persists. 4. Test the blower motor contactor. Check for proper voltage at the L1/ L2 lugs. Check the orange wire on the coil for 110 volts. Replace if needed.

APPENDIX A

Detailed Furnace Specifications

Furnace Technical Specifications

FURNACE MODEL	CB-3500	CB-5000
BTUH Input	350,000* @ 2.3 GPH	500,000* @ 3.0 GPH
Listed Fuels:	#2, #4, #5 Fuel Oils Used Crankcase Oil Used ATF (for U.S.) Used Hydraulic Oil	#2, #4, #5 Fuel Oils Used Crankcase Oil Used ATF (for U.S.) Used Hydraulic Oil
Cabinet Dimensions (LxWxH) inches	58 x 34.5 x 35.5	61 x 38.24 x 39.5
Furnace Dimensions w/ fan, Burner, and Louvers (LxWxH) inches	74 x 34.5 x 60.5	78 x 38.25 x 72.5
Approximate Weight (complete furnace system – uncrated)	836 lbs	1036 lbs
Mounting (NFPA-31)	1) Ceiling hung 2) non-combustible platform	1) Ceiling hung 2) non-combustible platform
Electrical Requirements (VAC @ 60 Hz)	Min. 220 volts, 60 Hz Max. 240 volts, 60 Hz	Min. 220 volts, 60 Hz Max. 240 volts, 60 Hz
Circuit Breaker	35 amps	35 amps
Wall Thermostat	24 volt (Battery Operated)	24 volt (Battery Operated)
Oil Pump	Suntec A2RA-7720	Suntec A2RA-7720
Oil Pump Motor	1/20 HP	1/20 HP
Pump Motor Rotation	CCW shaft end	CCW shaft end
Canister Filter	Lenz DH 750-100	Lenz DH 750-100
Stack Size	8"	10"
Blower Motor HP	2 HP	2 HP
Blower Motor Relay	30 amp double pole	30 amp double pole
Pump and Draft Inducer Relay	20 amp single pole	20 amp single pole
Blower / Fan Switch	F180	F180
Fan Limit Control	Honeywell L4064B 8" Probe	Honeywell L4064B 8" Probe
Fan Limit Settings	hi limit - 210 fan on - 120 fan off - 100	hi limit - 210 fan on - 120 fan off - 100
Auxiliary Hi-Temp Limit Switch	L290 (auto-reset)	L-290 (auto-reset)

Burner Technical Specifications

NOTE: These burner specifications apply to both furnace models, CB-3500 and CB-5000, except where differences are noted within the table.

Burner	CB-525-S2 (CB-3500) CB-525-S2 (CB-5000)
Ignition Transformer	Transformer 19,000 Volts
Nozzle	Delavan 9-5 (CB-3500) Delavan 9-11 (CB-5000)
Burner Motor	1/10 HP 3200 RPM w/ Centrifugal Switch
Burner Motor Rotation	CCW shaft end
Compressed Air Requirements	2.0 CFM @25 PSI (CB-3500) 2.5 CFM @25 PSI (CB-5000)
Oil Primary Control	Oil Primary Control (W/Pre/Post Purge)
Heater Element in Preheater Block	400 Watts
Air Pressure Switch	MPL 808
Setting for Preheater Thermostat	140 oF

Furnace Dimensions (CB-3500)

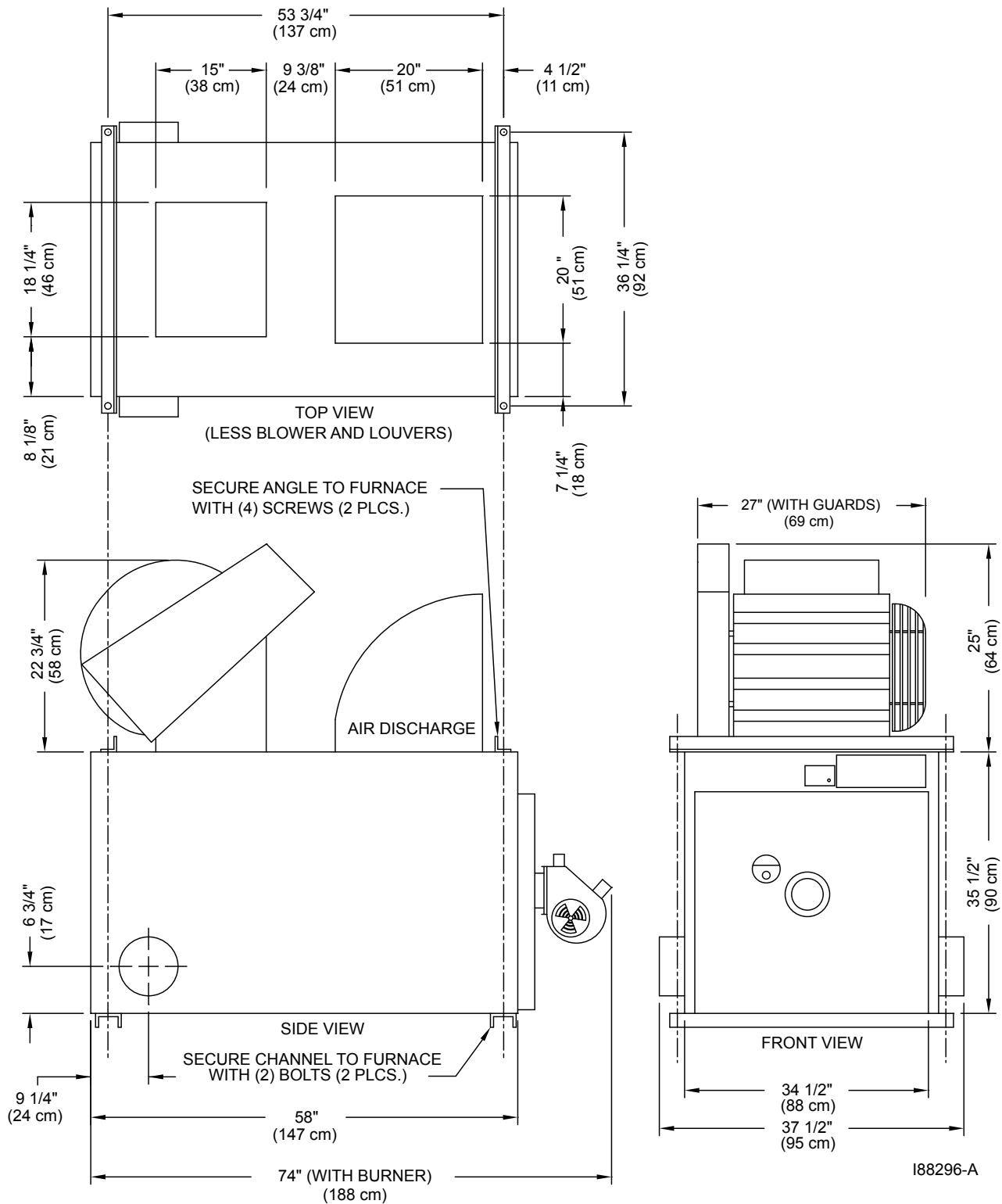

Furnace Dimensions (CB-5000)

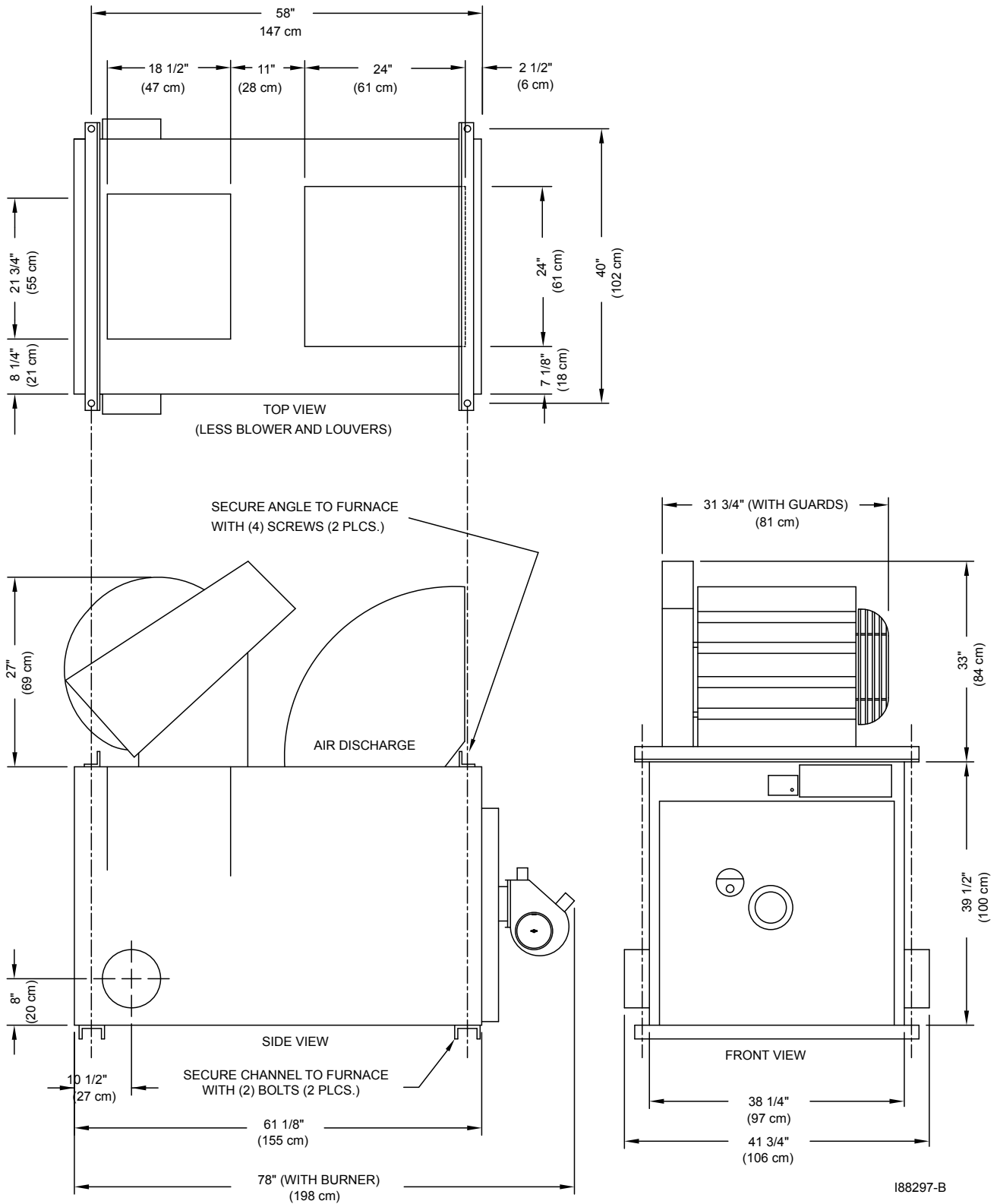

Burner Components (CB-3500 with CB-525-S2)

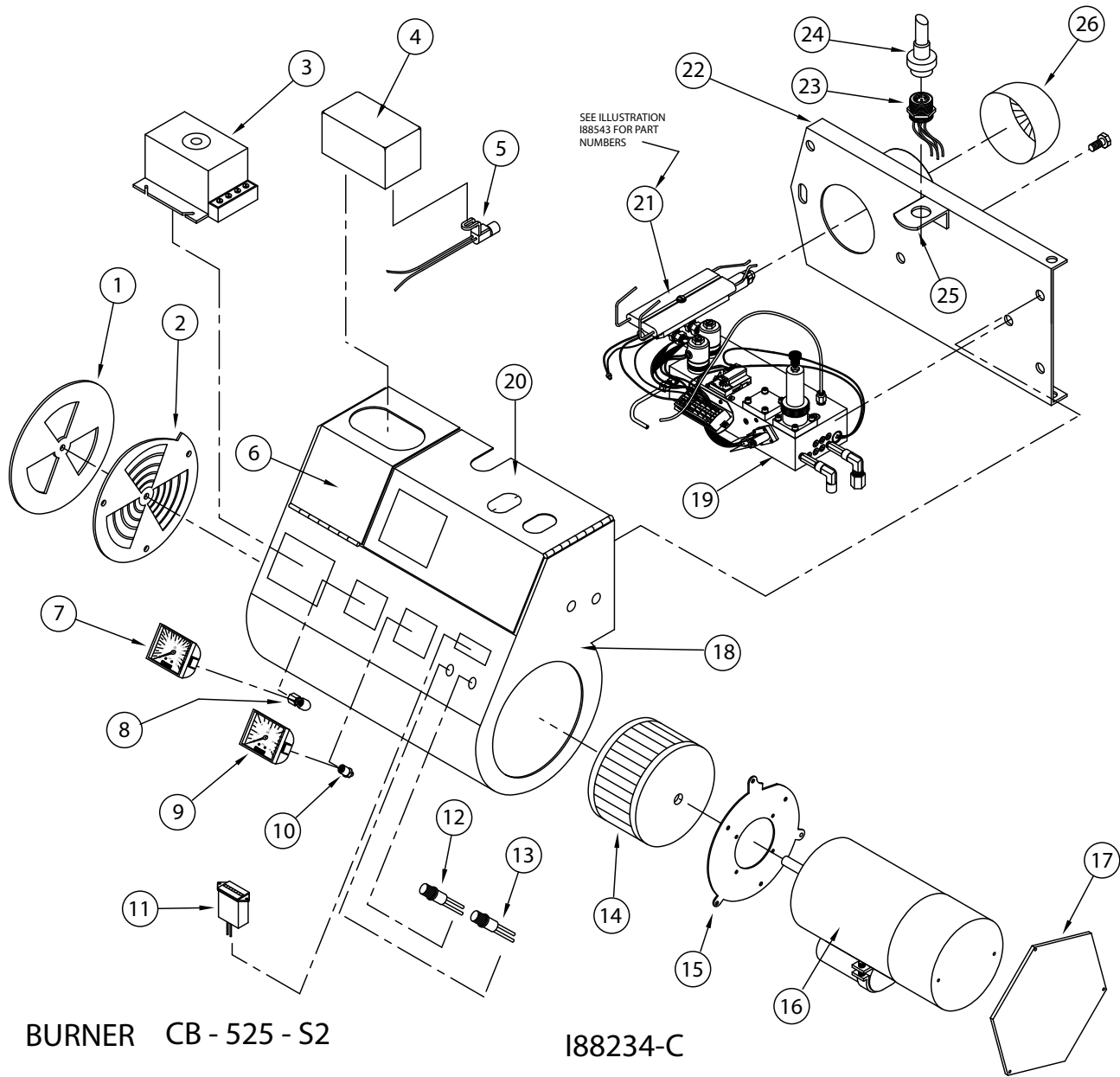

Figure A1 - CB-525-S2 Burner Component Detail (for CB-3500 Furnaces)

Burner Components (CB-525-S2) (continued)

<u>Item#</u>	<u>C.B. Part#</u>	<u>Qty.</u>	<u>Component Description</u>
1	26103	1	AIR INTAKE OUTER PLATE
2	11359	1	AIR INTAKE INNER PLATE
3	33409	1	PRIMARY CONTROL (w / Pre/Post Purge)
4	33335	1	ISOLATOR (OPTIONAL)
5	33189	1	IGNITER (TRANSFORMER)
6	33116	1	CAD CELL
7	11243	1	TRANSFORMER PLATE
8	32178	1	OIL GAUGE 0-15 PSI
9	32235	1	FEMALE ELBOW (3/16 T x 1/8 NPT)
10	32179	1	AIR GAUGE 0-60 PSI
11	32253	1	FEMALE ELBOW (1/8 TP x 1/8 NPT)
12	33297	1	HOUR METER (60 Hz)
13	33169	1	GREEN LIGHT (POWER)
14	33168	1	AMBER LIGHT (PUMP)
15	31113	1	FAN SQUIRREL CAGE
16	26044	1	MOTOR MOUNT PLATE
17	33175	1	BLOWER MOTOR
18	26053	1	RIGHT SIDE COVER
19	11335	1	HOUSING (INCLUDES ITEM 23)
20	13148	1	HEATER BLOCK ASSEMBLY
21	11265	1	COVER-HINGED
22	SEE NOTE ON DRAWING		NOZZLE ADAPTER ASSEMBLY
23	11334	1	HINGE MOUNTING PLATE
24	33149	1	CONNECTOR RECEPTACLE
25	33150	1	CONNECTOR PLUG
26	26052	1	LATCH BRACKET
27	11308	1	RETENTION HEAD

Burner Components (CB-5000 with CB-550-S2)

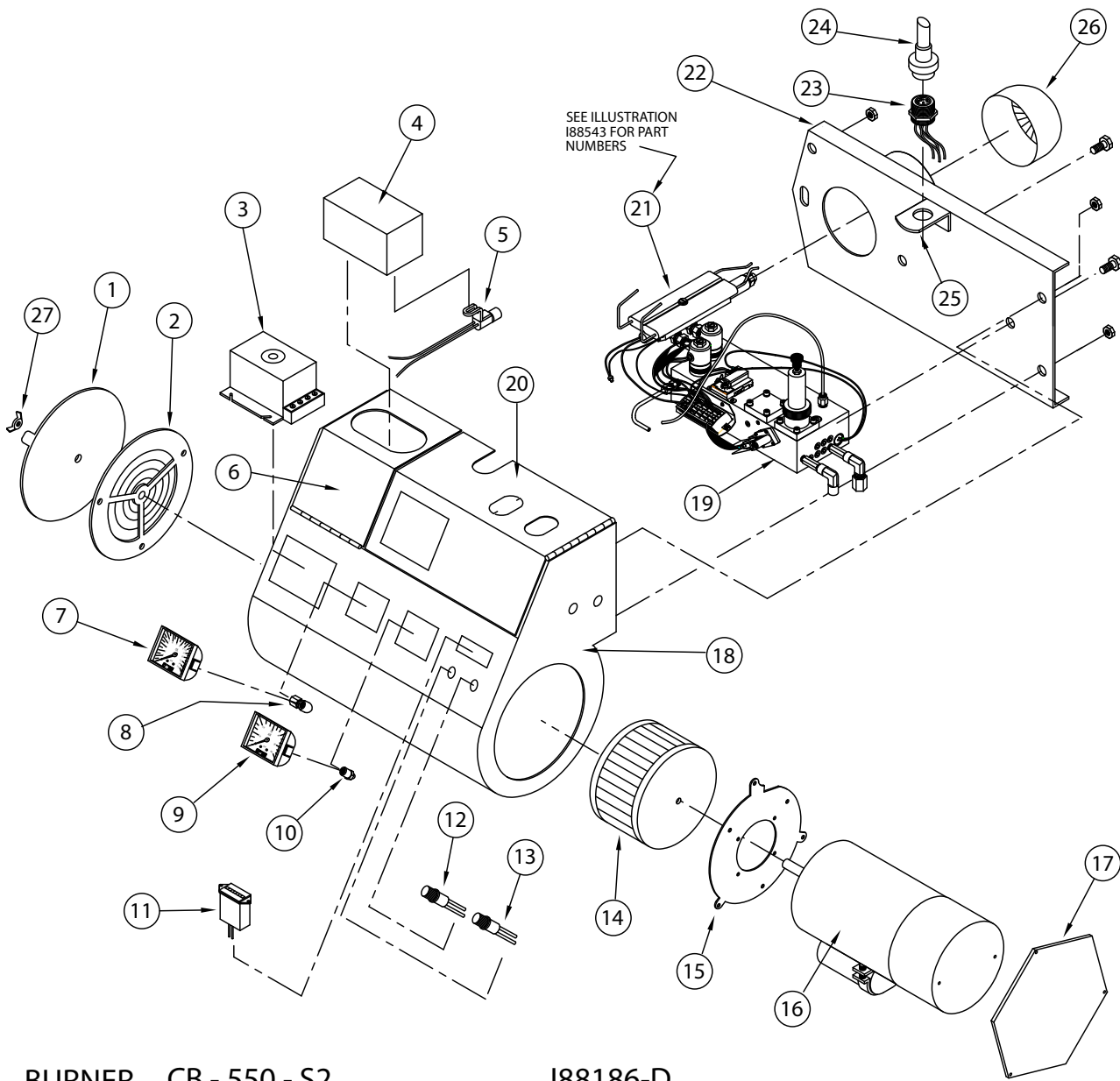
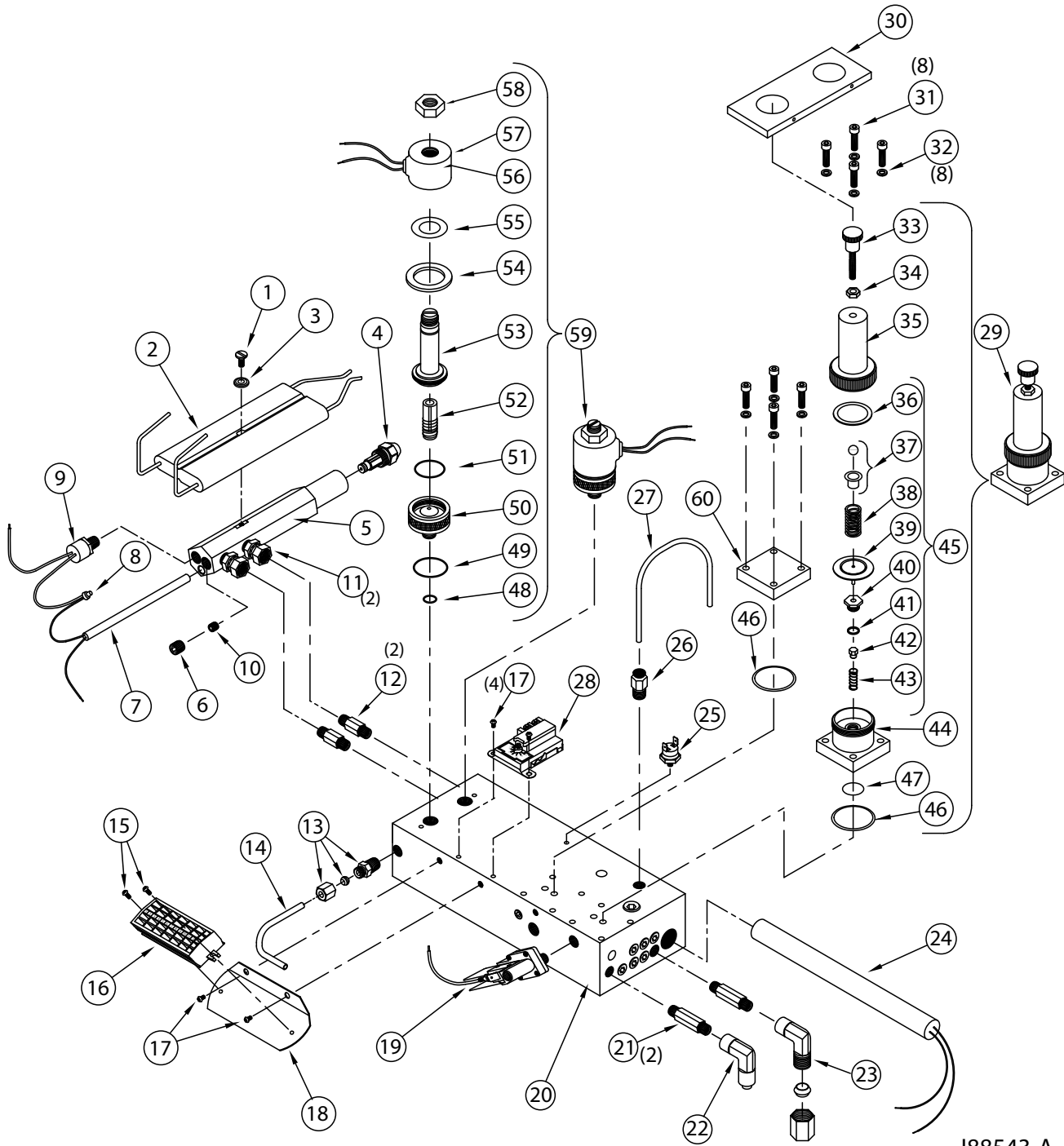

Figure A2 - CB-550-S2 Burner Component Detail (for CB-5000 Furnaces)

Burner Components (CB-550-S2) (continued)

<u>Item#</u>	<u>C.B. Part#</u>	<u>Qty.</u>	<u>Component Description</u>
1	11410	1	DRAFT PLATE, OUTER ASSEMBLY
2	26104	1	DRAFT PLATE, INNER ASSEMBLY
3	33409	1	PRIMARY CONTROL (w / Pre/Post Purge)
4	33189	1	IGNITER (TRANSFORMER)
5	33116	1	CAD CELL
6	11243	1	TRANSFORMER PLATE
7	32178	1	OIL GAUGE 0-15 PSI
8	32235	1	FEMALE ELBOW (3/16 T x 1/8 NPT)
9	32179	1	AIR GAUGE 0-60 PSI
10	32253	1	FEMALE ELBOW (1/8 TP x 1/8 NPT)
11	33297	1	HOUR METER (60 Hz)
12	33169	1	GREEN LIGHT (POWER)
13	33168	1	AMBER LIGHT (PUMP)
14	31113	1	FAN SQUIRREL CAGE
15	26044	1	MOTOR MOUNT PLATE
16	33175	1	BLOWER MOTOR
17	26053	1	RIGHT SIDE COVER
18	11335	1	HOUSING (INCLUDES ITEM 22)
19	13148	1	HEATER BLOCK ASSEMBLY
20	11265	1	COVER-HINGED
21	SEE NOTE ON DRAWING		NOZZLE ADAPTER ASSEMBLY
22	11334	1	HINGE MOUNTING PLATE
23	33149	1	CONNECTOR RECEPTACLE
24	33150	1	CONNECTOR PLUG
25	26052	1	LATCH BRACKET
26	11427	1	RETENTION HEAD
27	34417	1	5/16 WING NUT

Burner Components (continued)



I88543-A

Figure A3 - Preheater Block Assembly Component Detail

Burner Components (continued)

<u>Item#</u>	<u>C.B. Part#</u>	<u>Qty.</u>	<u>Component Description</u>
1	34169	1	ELECTRODE SCREW - 10-32 x 3/4
2	33183	1	SINGLE PIECE ELECTRODE
3	34165	1	WASHER
4	32000	1	9 - 5 NOZZLE
	32002	1	9-11 NOZZLE
5	13150	1	NOZZLE ADAPTOR
6	32007	1	PLUG - 1/8 NPT
7	33298	1	140 WATTS HEATER
8	33381	1	INSULATED CAP CRIMP CONNECTOR
9	33418	1	THERMOSTAT L-130
10	32199	1	PLUG - 1/16 NPT
11	32050	2	SWIVEL FITTING
12	32189	2	HEX NIPPLE - 1/8 NPT x 1-1/2
13	32043	1	MALE CONNECTOR - 3/16T x 1/8 NPT
14	54020	1	3/16 COPPER TUBING(OIL GAUGE LINE)
15	32201	2	MACH. SCREW PHILLIPS HD. 6-32 x 3/8 Z
16	33247	1	TERMINAL BLOCK
17	34036	4	MACH. SCREW PHILLIPS HD. 6-32 x 1/4 Z
18	26059	1	TERMINAL BLOCK BRACKET
19	33057	1	AIR PRESSURE SWITCH
20	26090	1	HEATER BLOCK
21	32190	2	HEX NIPPLE - 1/8 NPT x 2
22	32202	1	FEMALE ELBOW (FOR 1/4" AIR LINE)
23	32201	1	FEMALE ELBOW (FOR 3/8" OIL LINE)
24	33173	1	PRE-HEATER ELEMENT (400 WATTS)
25	33041	1	PROVING SWITCH (NORMALLY OPEN)
26	32325	1	MALE FITTING 1/8 x 1/8 NPT (FOR AIR GAUGE LINE)
27	54020	1	3/16 COPPER TUBING(OIL GAUGE LINE)
28	33011	1	HEATER BLOCK THERMOSTAT(NORMALLY CLOSED)
29	32359	2	REGULATOR SURFACE MOUNT
30	14090	1	REGULATOR LOCK PLATE
31	34148	8	REGULATOR MOUNTING SCREW
32	34114	8	LOCK WASHER #8 Z
33	34147	2	REGULATOR THREADED STEM
34	34022	2	HEX NUT - 10-32 Z
35	32306	2	BONNET
36	32226	2	DIAPHRAGM RING
37	32364	2	CAP AND BALL ASSEMBLY
38	32227	2	COMPRESSION SPRING
39	32360	2	DIAPHRAGM
40	32361	2	BRASS POPPET SEAT
41	32223	2	POPPET 'O' RING
42	32316	2	POPPET VALVE
43	32221	2	POPPET SPRING
44	32362	2	BASE
45	13146	2	REGULATOR KIT COMPONENTS
46	32308	2	REGULATOR OUTER "O" RING
47	32309	2	REGULATOR INNER "O" RING
48	33311	2	SOLENOID INNER "O" RING
49	33312	2	SOLENOID OUTER "O" RING
50	33313	2	MANIFOLD MOUNT SOLENOID BODY
51	33314	2	BODY "O" RING
52	33315	2	PLUNGER ASSEMBLY
53	33316	2	PLUNGER GUIDE ASSEMBLY
54	33317	2	FLUX PLATE
55	33318	2	WASHER SEAL
56	33319	2	COIL
57	33320	2	COIL HOUSING
58	33321	2	NUT
59	32322	2	AIR/OIL SOLENOID ASSEMBLY
60	26107	1	REG. SQUARE CAP

Burner Components (continued)

INSTALLATION OF THE SPINNER RETENTION HEAD

THE SPINNER RETENTION HEAD FITS INSIDE THE BURNER TUBE AND REQUIRES (3) SELF-TAPPING SCREWS. IT IS VERY IMPORTANT THAT THE SPINNER HEAD IS NOT TIPPED FROM SIDE TO SIDE OR FROM TOP TO BOTTOM.

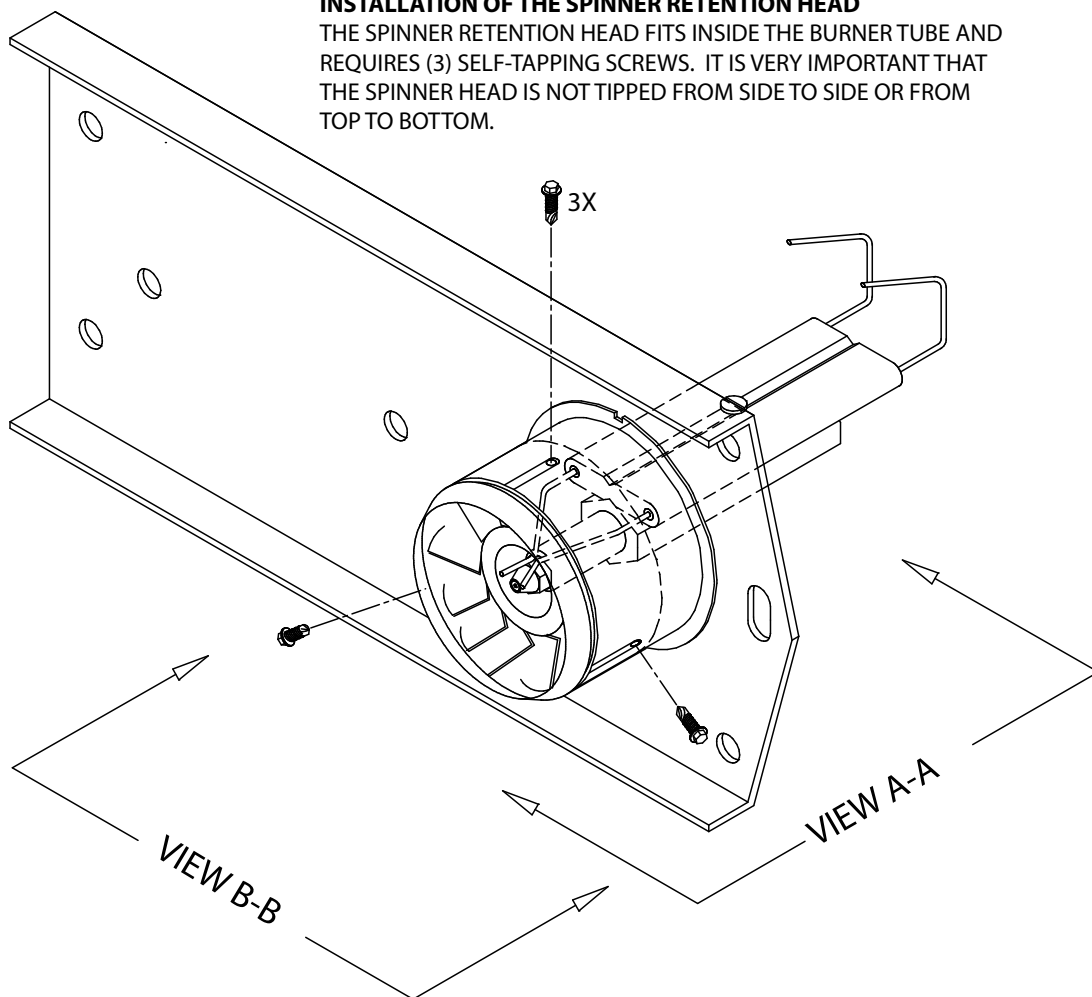

USE PROVIDED SCREWDRIVER AS WEDGE TO HOLD THE SPINNER RETENTION HEAD IN POSITION. THEN TIGHTEN THE THREE SCREWS TO LOCK THE HEAD IN POSITION.

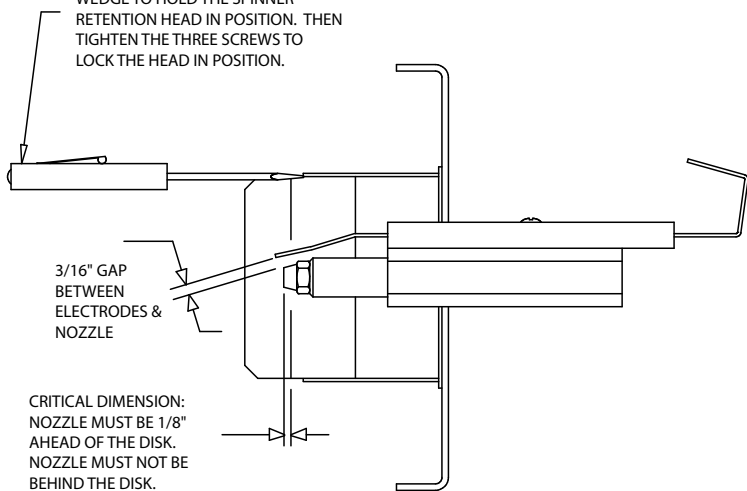

3/16" GAP BETWEEN ELECTRODES & NOZZLE

CRITICAL DIMENSION: NOZZLE MUST BE 1/8" AHEAD OF THE DISK. NOZZLE MUST NOT BE BEHIND THE DISK.

SIDE VIEW A-A

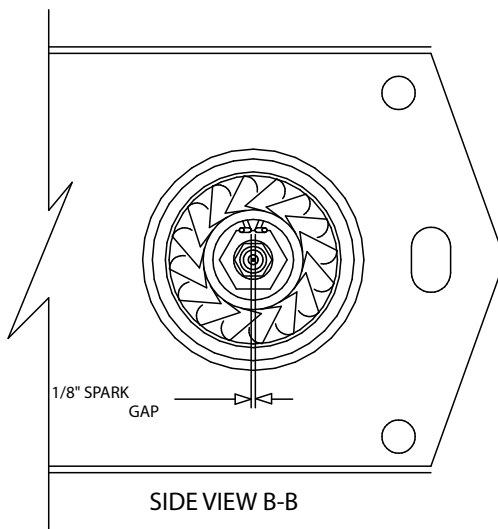

1/8" SPARK GAP

SIDE VIEW B-B

188377

Figure A4 - Burner Electrode Specifications with Spinner Retention Head

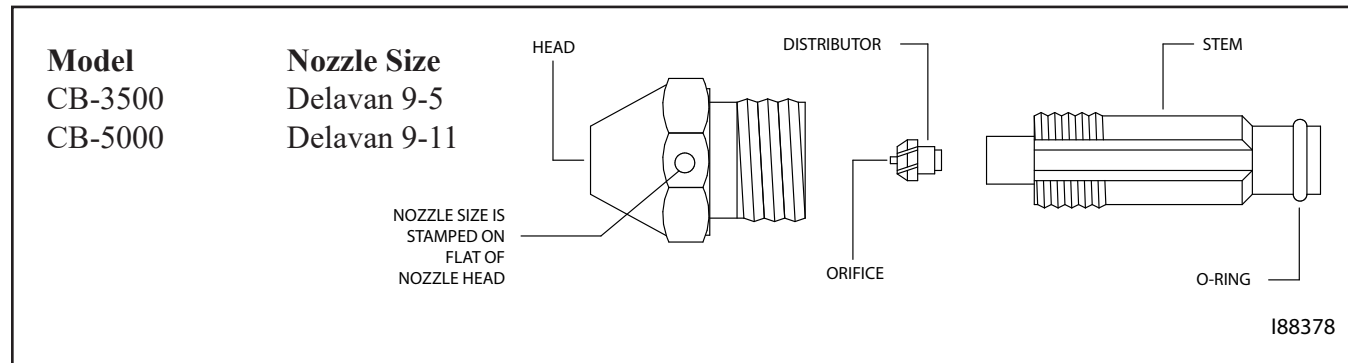
Burner Components (continued)**Removing the Nozzle for Cleaning:**

NOTE: Due to swivel fittings on the air and oil lines, it is not necessary to disconnect these lines when swinging the burner open.

1. Remove the lock-down nut on the mounting flange bolt.
2. Disconnect the burner power cable.
3. Carefully swing the burner open to its maintenance position.
4. Remove the nozzle from the nozzle adapter with a 5/8" socket.

Cleaning the Nozzle:

1. Unscrew the stem from the nozzle head.
2. Spray WD-40 or equivalent through the orifice to thoroughly remove any blockage.
CAUTION: DO NOT damage or deform the nozzle orifice; DO NOT use a torch tip cleaner or other inappropriate device to clean the orifice. If the blockage is a "tarry" material or a hard, black material, call your Clean Burn dealer for service.
3. Flush all components with WD-40 to remove oil residues.
4. Reassemble the nozzle components. When tightening the stem, just barely "snug" it down. DO NOT overtighten.
5. Check the O-ring on the nozzle stem. Replace the O-ring if it is in the least bit cut or deformed.
6. Lubricate the O-ring on the nozzle stem with a couple of drops of new motor oil, then re-install the nozzle.
7. Check the electrodes for proper gap and clearances.
8. Re-install the burner and adjust for optimal performance as described in Section 6.

NOTE: If the nozzle plugs within a few days after cleaning, call your Clean Burn Dealer for service.

Figure A5 - Cleaning the Nozzle

**CABINET
CB-3500
(# 11315)**

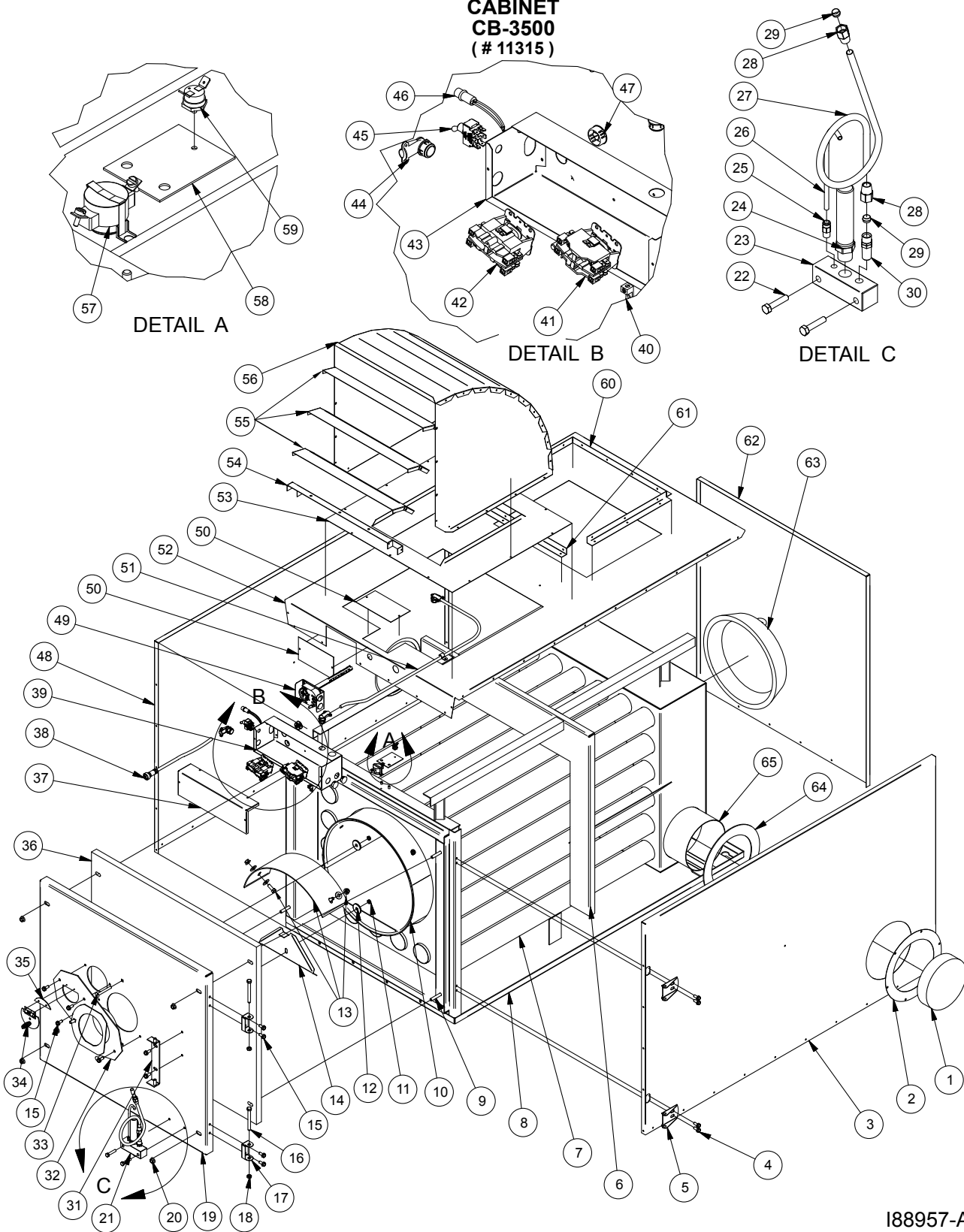

I88957-A

Operator's Manual: Models CB-3500 & CB-5000

<u>ITEM#</u>	<u>PART#</u>	<u>Description</u>	<u>ITEM#</u>	<u>PART#</u>	<u>Description</u>
1.	31091	DUCT CAP ROUND 8"	•	24098	HANGER CHANNEL
2.	21010	STACK PIPE FLASH RING	•	24099	HANGER ANGLE
3.	24077	SIDE - RIGHT	•	11137	DOOR A. CB-3500
4.	34028	5/16-18 X 3/4 SERR HEX FLANG	•	14170	PUMP MTR CB-3500 A
5.	21057	HINGE BRACKET	•	14174	COMPRESSOR AIR LARGE (1/2HP)
6.	24069	DIVIDER	•	24062	FRONT FLUE PLATE
7.	21102	FLUE TUBE CB3500/CB5000	•	24065	FRONT FLUE CAP - BOTTOM
8.	24068	BASE	•	24066	BACK FLUE CAP
9.	34126	3/8-16 X 2 HHCS GR-5	•	31111	SPRING HANDLE
10.	24116	FIRE DRUM	•	31170	DAMPER 8"
11.	34121	5/16-18 TOP LOCK NUT S.S.	•	33283	THERMOSTAT - WALL
12.	21039	.438 X 1.5 X .135 FLAT WASHER	•	34162	STOVE CEMENT - HIGH TEMP
13.	70418	COMB CHAMBER BAND KIT - 3500	•	42027	LABEL - WARNING - BURN/VOLTAGE
	24182	REINFORCEMENT BAND - 3500	•	42030	LABEL - VO LTAGE WARNING
	34397	3/8 X 1 HHCS - SS	•	42045	LABEL - MADE IN USA - 2X3
	34398	3/8 SERRATED FLANGE NUT - SS	•	42068	LABEL - TANGLE / CUTTING
	34399	3/8 SPLIT LOCK WASHER - SS	•	42144	LABEL - CB-3500
14.	11213	DOOR APRON	•	42146	LABEL 220 V
15.	34118	5/16-18 X 3/4 HEX WASHER HEAD	•	42174	LABEL FURN CB 3500
16.	34119	3/8-16 X 3 HHCS GR-2 ZINC	•	42197	LABEL - PAT PEND
17.	21056	HINGE BRACKET	•	42216	LABEL-LOGO-ENG'D LIKE NO OTHER
18.	34095	3/8-16 S TOVER L/N GR-B CAD/WAX	•	42217	LABEL - AIR OIL
19.	24075	OUTSIDE DOOR	•	42227	LABEL-FURN CAB E SCH
20.	34009	3/8-16 HEX SERR FLANGE NUT PLT	•	42231	LABEL - PRIME PUMP/RUN BURNER
21.	14102	CB-3500 HOOK-UP A	•	42302	LABEL PULLEY INSTRCTNS (31072)
22.	34051	5/16-18 X 1 1/2 HHCS GR-2 ZINC	•	42366	LABEL - TANK WARNING
23.	21101	CONNECTOR BLOCK	•	42367	LABEL - FURNACE WARNING
24.	32311	ACCUMULATOR	•	43144	OPERATORS MANUAL CB 3500, 5000
25.	32039	ADAPT 1/4 OD X 1/8 P	•	44037	FURN CAB ELEC SCHEM
26.	13017	AIR LINE ASSEMBLY	•	11315	FURNACE CABINET CB-3501 A
27.	13128	OIL LINE A			
28.	32304	NUT - LONG			
29.	32303	SLEEVE			
30.	32245	SWIVEL 1/4NPTM,1/4NPTF			
31.	11033	HINGE BRACKET W A			
32.	11143	BURNER MOUNT W A			
33.	34120	5/16-18 X 2 3/4 CARR BOLT S.S.			
34.	11325	INSPECTION DOOR A			
35.	21076	PORT CAP			
36.	24103	DOOR INSULATION			
37.	21114	LID			
38.	3315	CONNECTOR PLUG			
39.	12214	JUNCTION BOX ASSY.			
40.	33145	SCREW LUG			
41.	33182	CONTACTOR 240V			
42.	33207	CONT 120V 60HZ 1POLE			
43.	21113	BOX - JUNCTION			
44.	33273	CONNECTOR 90 DEG. SNAP-TITE			
45.	33286	SWITCH DPDT ON-ON			
46.	33186	AMBER LIGHT 120V			
47.	33299	PLASTIC WIRE PROT			
48.	24080	SIDE - LEFT			
49.	33245	FAN LIMIT SWITCH			
50.	24119	COVER			
51.	14173	MOTOR HARNESS, CB3501			
52.	24079	TOP			
53.	24108	ORIFICE			
54.	24114	3500 DISCHARGE - ANGLE BOTTOM			
55.	24092	LOUVER			
56.	14160	DIFFUSER OUTLET 3500 A			
57.	33230	FAN SWITCH - SURFACE MOUNT 180			
58.	25115	PLATE			
59.	33288	AUXIL HI LIMIT-AUTO RESET 290			
60.	24082	BLOWER ANGLE			
61.	24083	BLOWER CLOSING ANGLE			
62.	24078	BACK			
63.	31232	ENERGY RETENTION DISC			
64.	24100	RING			
65.	22076	STACK PIPE COLLAR			

BLOWER ASSEMBLY CB-3500

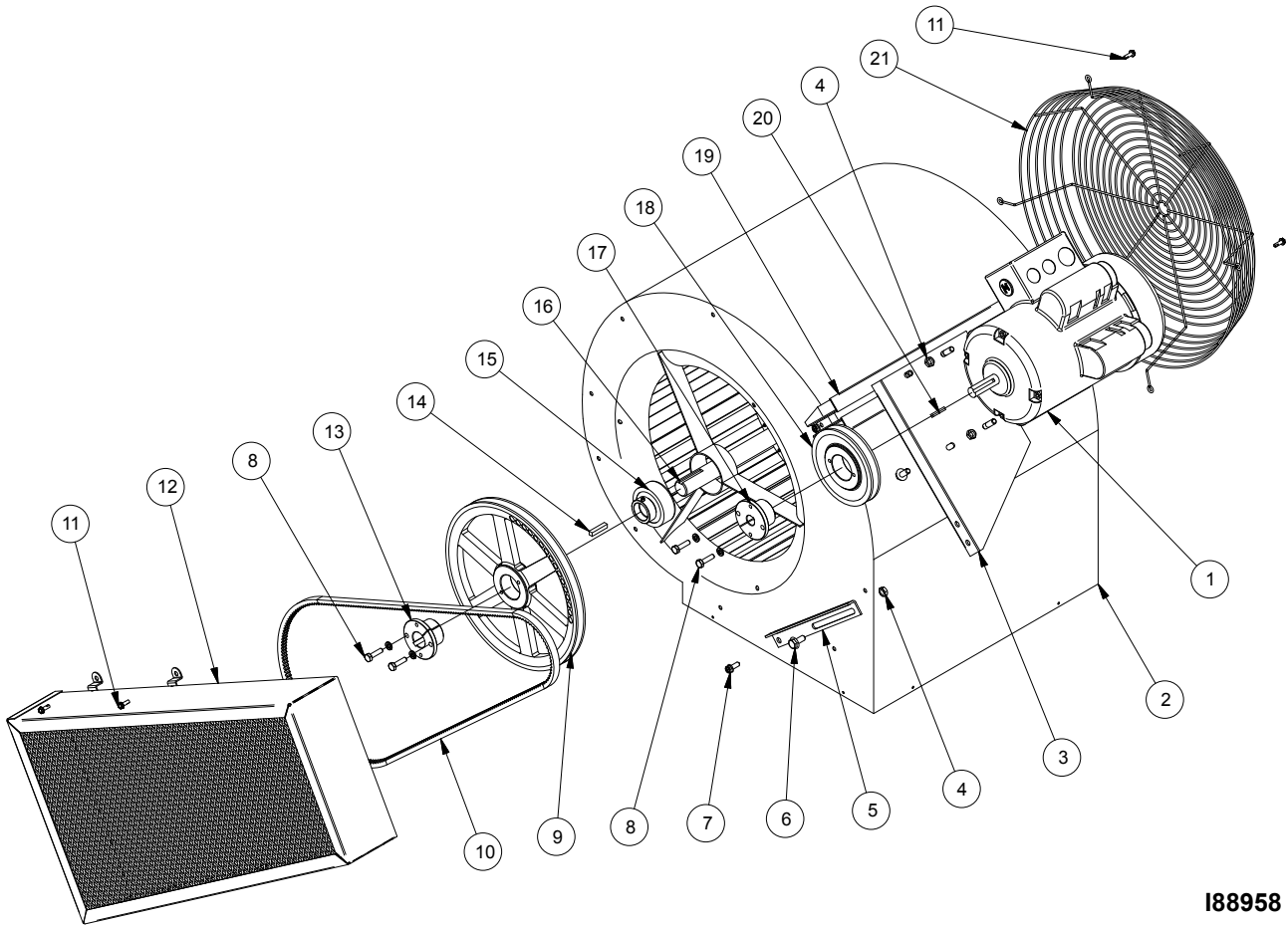

188958

Operator's Manual: Models CB-3500 & CB-5000

<u>ITEM#</u>	<u>PART#</u>	<u>Description</u>	<u>ITEM#</u>	<u>PART#</u>	<u>Description</u>
1.	33533	BLOWER MOTOR 2HP	•	14045	ACC BAG CB-3500, CB-5000 A.
2.	31084	BLOWER			
3.	24087	MOTOR MOUNT			
4.	34072	5/16-18 STOVER TOP LOCK NUT			
5.	25046	ANGLE FRONT			
6.	34328	5/16-18 X 3/4 HEX HEAD FLANGE			
7.	34159	1/4 X 3/4 SLOTTED IND HEX			
8.	34214	1/4-20 X 1 HHCS GR-5 ZINC			
9.	31225	BLOWER PULLEY 3500/5000			
10.	31229	BLOWER BELT 3500 - A-BELT			
11.	34116	10 X 5/8 HEX WASHER HEAD TEK Z			
12.	11124	BELT GUARD ASSY			
13.	31226	SHEAVE BUSHING 1"			
14.	21013	1 KEY 1/4 X 1 1/4			
15.	31192	REPLACEMENT BEARING PACKAGE			
16.	31194	1" SHAFT W/KEYWAY (15")			
17.	31238	SHEAVE BUSHING 7/8"			
18.	31223	MOTOR PULLEY 3500 BLOWER			
19.	31187	MOTOR MOUNT BRACKET			
20.	21012	9 KEY SQ. 3/16 X 1			
21.	31228	BLOWER WIRE GUARD 3500/5000			

**CABINET
CB-5000
(# 11302)**

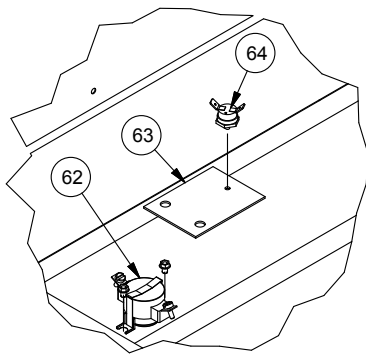

DETAIL A

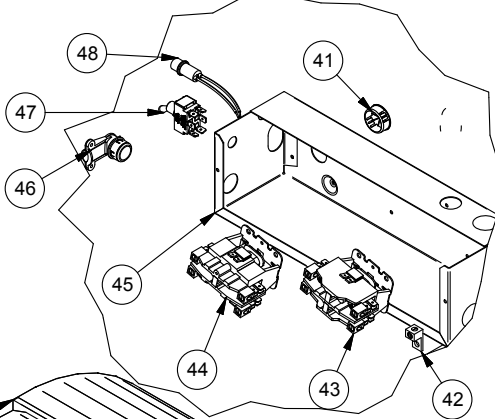

DETAIL B

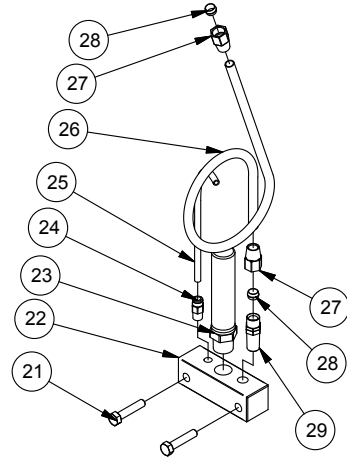

DETAIL C

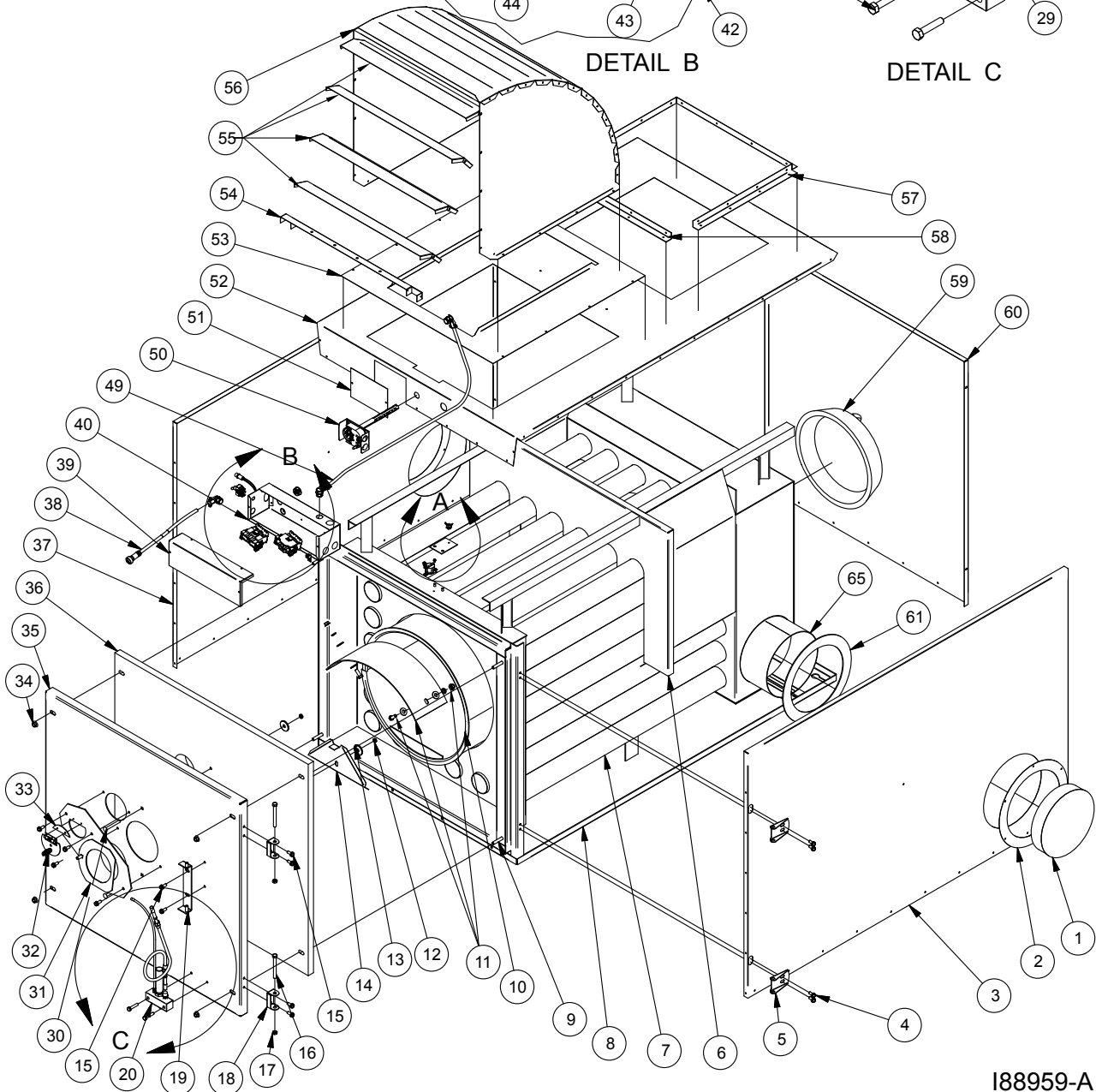

188959-A

Operator's Manual: Models CB-3500 & CB-5000

<u>ITEM#</u>	<u>PART#</u>	<u>Description</u>	<u>ITEM#</u>	<u>PART#</u>	<u>Description</u>
1.	31092	DUCT CAP ROUND 10" - 28 GA.	•	14084	FIBERGLASS ROPE A
2.	25032	STACK PIPE FLASH RING DH	•	25096	HANGER CHANNEL
3.	25085	SIDE - RIGHT	•	25097	HANGER ANGLE
4.	34028	5/16-18 X 3/4 SERR HEX FLANG	•	34162	STOVE CEMENT - HIGH TEMP
5.	21057	HINGE BRACKET	•	11142	DOOR A. CB-5000
6.	25110	DIVIDER	•	13003	OIL PUMP ASSEMBLY
7.	21102	FLUE TUBE CB3500/CB5000	•	14171	PUMP MTR CB-5000 A
8.	25078	BASE	•	25073	FRONT FLUE PLATE
9.	34126	3/8-16 X 2 HHCS GR-5	•	25075	FRONT FLUE CAP- BOTTOM
10.	25107	FIRE DRUM	•	25076	BACK FLUE CAP
11.	70419	COMB CHAMBER BAND KIT - 5000	•	25105	FRONT FLUE CAP - TOP
	25130	REINFORCEMENT BAND - 5000	•	25113	BACK FLUE PLATE
	34397	3/8 X 1 HHCS - SS	•	31192	REPLACEMENT BEARING PACKAGE
	34398	3/8 SERRATED FLANGE NUT - SS	•	31090	BALL BEARING (grainger1508886)
	34399	3/8 SPLIT LOCK WASHER - SS	•	42027	LABEL - WARNING - BURN/VOLTAGE
12.	34121	5/16-18 TOP LOCK NUT S.S.	•	42030	LABEL - VO LTAGE WARNING
13.	21039	.438 X 1.5 X .135 FLAT WASHER	•	42045	LABEL - MADE IN USA - 2X3
14.	11213	DOOR APRON	•	42068	LABEL - TANGLE / CUTTING
15.	34118	5/16-18 X 3/4 HEX WASHER HEAD	•	42145	LABEL CB-5000
16.	34119	3/8-16 X 3 HHCS GR-2 ZINC	•	42146	LABEL 220 V
17.	34095	3/8-16 S TOVER L/N GR-B CAD/WAX	•	42175	LABEL FURN CB 5000
18.	21056	HINGE BRACKET	•	42197	LABEL - PAT PEND
19.	11033	HINGE BRACKET W A	•	42216	LABEL-LOGO-ENG'D LIKE NO OTHER
20.	14103	CB-5000 HOOK-UP A	•	42227	LABEL-FURN CAB E SCH
21.	34051	5/16-18 X 1 1/2 HHCS GR-2 ZINC	•	42231	LABEL - PRIME PUMP/RUN BURNER
22.	21101	CONNECTOR BLOCK	•	42302	LABEL PULLEY INSTRCTNS (31072)
23.	32311	ACCUMULATOR	•	43144	OPERATORS MANUAL CB 3500, 5000
24.	32039	ADAPT 1/4 OD X 1/8 P	•	44037	FURN CAB ELEC SCHEM
25.	13017	AIR LINE ASSEMBLY	•	54013	ROPE-FIBERGLASS HD 250 W/ADH.
26.	13129	OIL LINE A	•	70046	DRAFT INDUCER DI-3
27.	32304	NUT - LONG	•	70059	BLOWER SHAFT
28.	32303	SLEEVE	•	70418	COMB CHAMBER BAND KIT - 3500
29.	32245	SWIVEL 1/4NPTM,1/4NPTF	•	11302	FURNACE CABINET CB-5001
30.	34120	5/16-18 X 2 3/4 CARR BOLT S.S.			
31.	11143	BURNER MOUNT W A			
32.	11325	INSPECTION DOOR A			
33.	21076	PORT CAP			
34.	34009	3/8-16 HEX SERR FLANGE NUT PLT			
35.	25083	OUTSIDE DOOR			
36.	25119	DOOR INSULATION			
37.	25088	SIDE - LEFT			
38.	33150	CONNECTOR PLUG			
39.	21114	LID			
40.	12214	JUNCTION BOX A			
41.	33299	PLASTIC WIRE PROT			
42.	33145	SCREW LUG			
43.	33182	CONTACTOR 240V			
44.	33207	CONT 120V 60HZ 1POLE			
45.	21113	BOX - JUNCTION			
46.	33273	CONNECTOR 90 DEG. SNAP-TITE			
47.	33286	SWITCH DPDT ON-ON			
48.	33186	AMBER LIGHT 120V			
49.	12215	MOTOR HARNESS (CB5001)			
50.	33245	FAN LIMIT SWITCH			
51.	25114	COVER			
52.	25087	TOP			
53.	25070	ORIFICE PLATE			
54.	21107	5000 DISCHARGE - ANGLE BOTTOM			
55.	24034	LOUVER			
56.	14161	DIFFUSER OUTLET 5000 A			
57.	25067	BLOWER FLANGE			
58.	25068	BLOWER CLOSING ANGLE			
59.	31232	ENERGY RETENTION DISC			
60.	25086	BACK			
61.	25100	RING			
62.	33230	FAN SWITCH - SURFACE MOUNT 180			
63.	25115	PLATE			
64.	33288	AUXIL HI LIMIT-AUTO RESET 290			
65.	25014	STOVE PIPE COLLAR			

BLOWER ASSEMBLY CB-5000

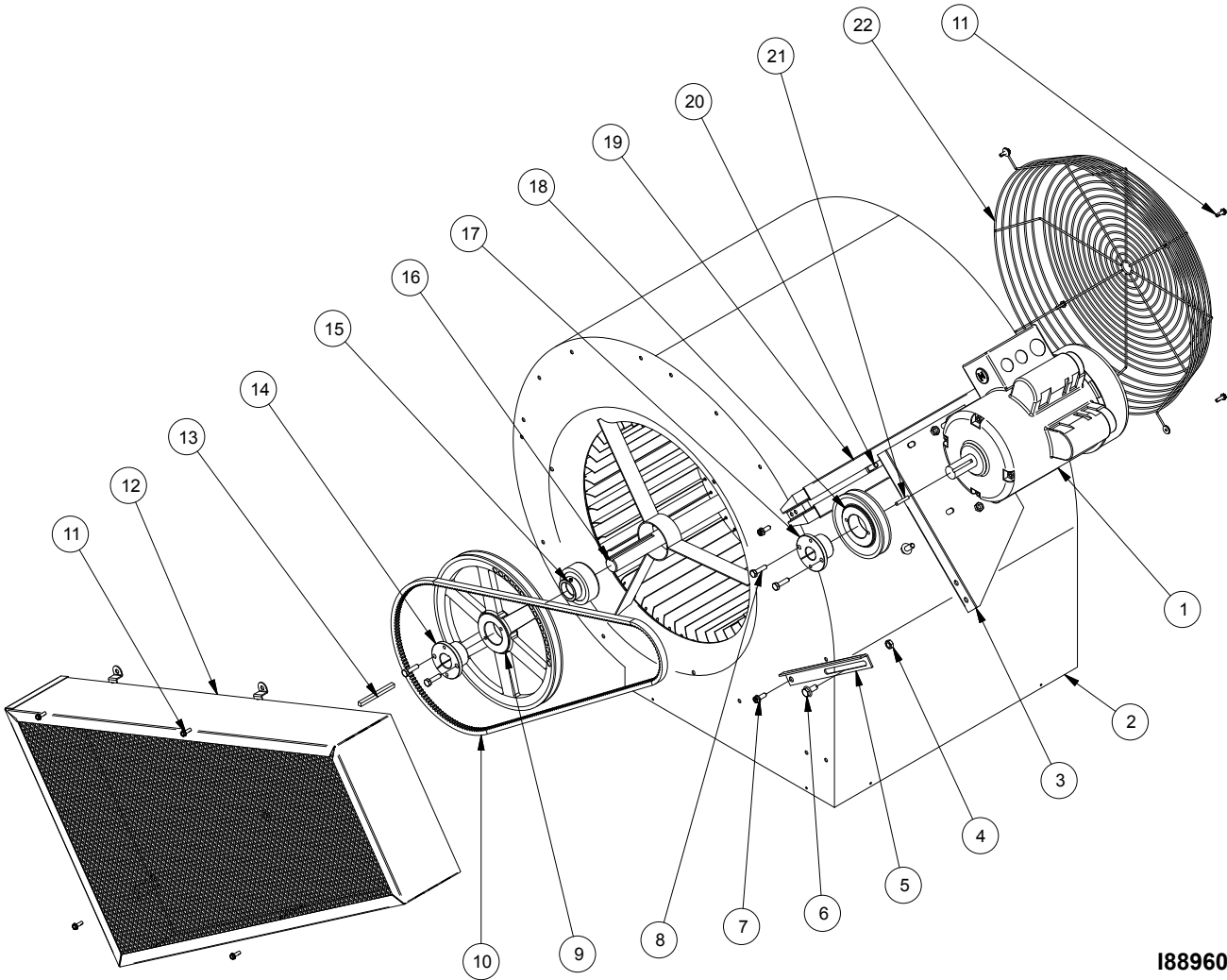

I88960

Operator's Manual: Models CB-3500 & CB-5000

<u>ITEM#</u>	<u>PART#</u>	<u>Description</u>	<u>ITEM#</u>	<u>PART#</u>	<u>Description</u>
1.	33533	BLOWER MOTOR 2HP	•	14045	ACC BAG CB-3500, CB-5000 A.
2.	31056	BLOWER			
3.	24087	MOTOR MOUNT			
4.	34072	5/16-18 STOVER TOP LOCK NUT			
5.	25046	ANGLE FRONT			
6.	34328	5/16-18 X 3/4 HEX HEAD FLANGE			
7.	34159	1/4 X 3/4 SLOTTED IND HEX			
8.	34214	1/4-20 X 1 HHCS GR-5 ZINC			
9.	31225	BLOWER PULLEY 3500/5000			
10.	31230	BLOWER BELT 5000 - A-BELT			
11.	34116	10 X 5/8 HEX WASHER HEAD TEK Z			
12.	11215	BELT GUARD ASSY			
13.	21013	1 KEY 1/4 X 1 1/4			
14.	31226	SHEAVE BUSHING 1"			
15.	31192	REPLACEMENT BEARING PACKAGE			
16.	31195	1" SHAFT W/KEYWAY (18")			
17.	31238	SHEAVE BUSHING 7/8"			
18.	31227	MOTOR PULLEY 5000 BLOWER			
19.	31188	MOTOR MOUNT BRACKET			
20.	34290	5/16-18 X 3/4 SQUARE HEAD			
21.	21012	9 KEY SQ. 3/16 X 1			
22.	31228	BLOWER WIRE GUARD 3500/5000			

Metering Pump Components

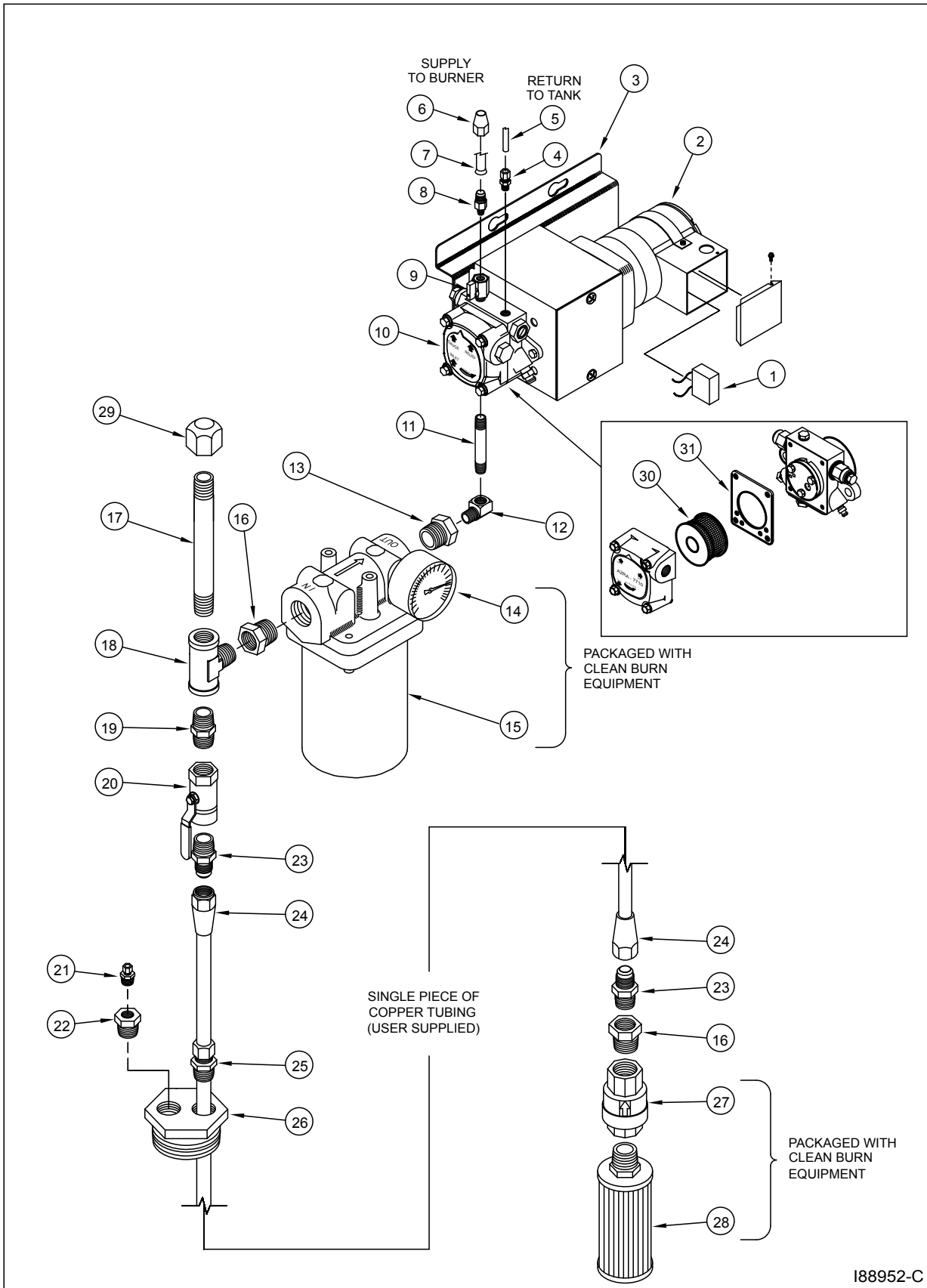

188952-C

APPENDIX B

Wiring Diagrams

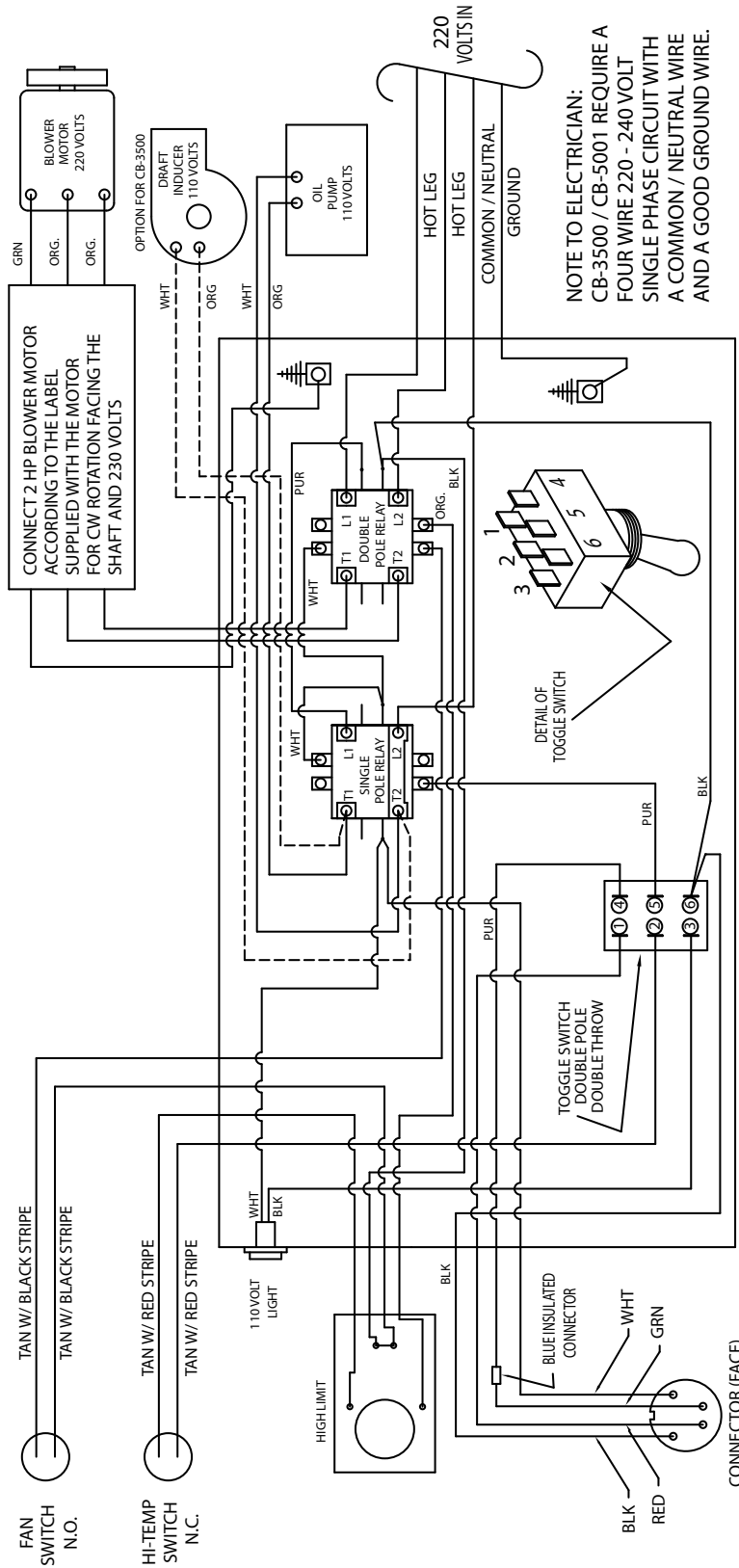

IMPORTANT NOTE TO ELECTRICIAN: Furnace models CB-3500 and CB-5000 require a four wire, 220-240 volt single-phase circuit with a common/neutral wire and a ground wire. The blower motor is rated for 208-230 volt operation. The burner, oil pump, and options (i.e. draft inducer) require 110-120 volts.

I44037

Figure B1 - CB-3500/CB-5000 Furnace Wiring Diagram (with Draft Inducer - standard for CB-5000; optional with CB-3500)

Wiring Diagrams (continued)

Burner Wiring Diagram for Primary Control 33409 - 33165

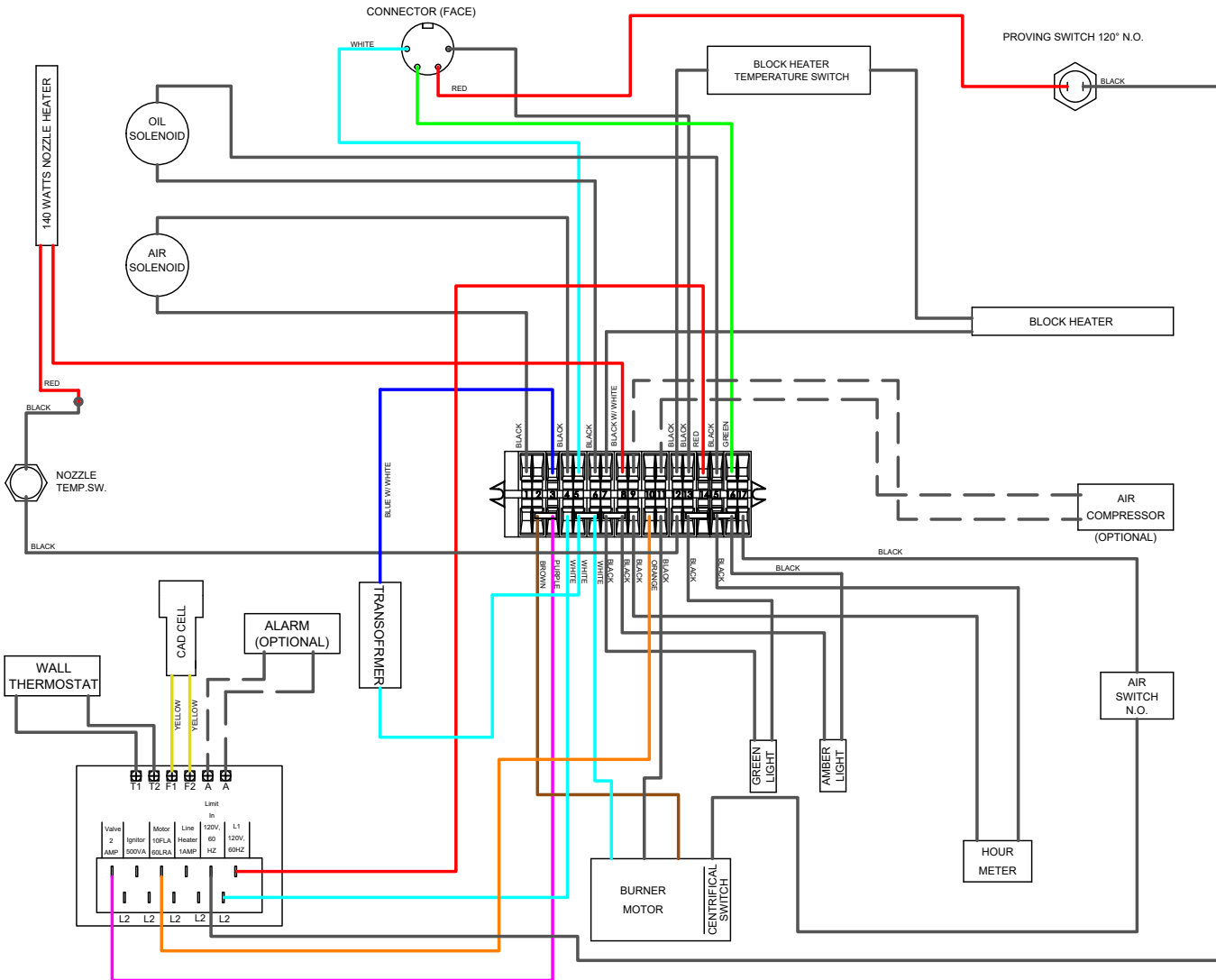

NOTE: WHEN RELEASING OR INSTALLING WIRES ON THE TERMINAL STRIP USE THE SMALL SCREWDRIVER SUPPLIED WITH THE BURNER TO RELEASE THE TERMINAL JAWS. TO LOCATE THE SCREWDRIVER, OPEN THE HINGED ACCESS PLATE ON THE TOP OF THE BURNER. THE SCREWDRIVER IS CLIPPED TO THE INSIDE OF THE BURNER HOUSING ON THE RIGHT.

TO RELEASE OR INSTALL A WIRE, CAREFULLY PUSH THE BLADE OF THE SCREWDRIVER INTO THE RELEASE SLOT ON THE TERMINAL STRIP UNTIL YOU FEEL THE JAWS "SNAP" WIDE OPEN. LEAVE THE BLADE IN THE RELEASE SLOT TO REMOVE OR INSTALL A WIRE. TO RELEASE THE JAWS, CAREFULLY PULL THE BLADE OF THE SCREWDRIVER FROM THE RELEASE SLOT.

Wiring Diagrams (continued)

Old Burner Wiring Diagram for Primary Control 33409

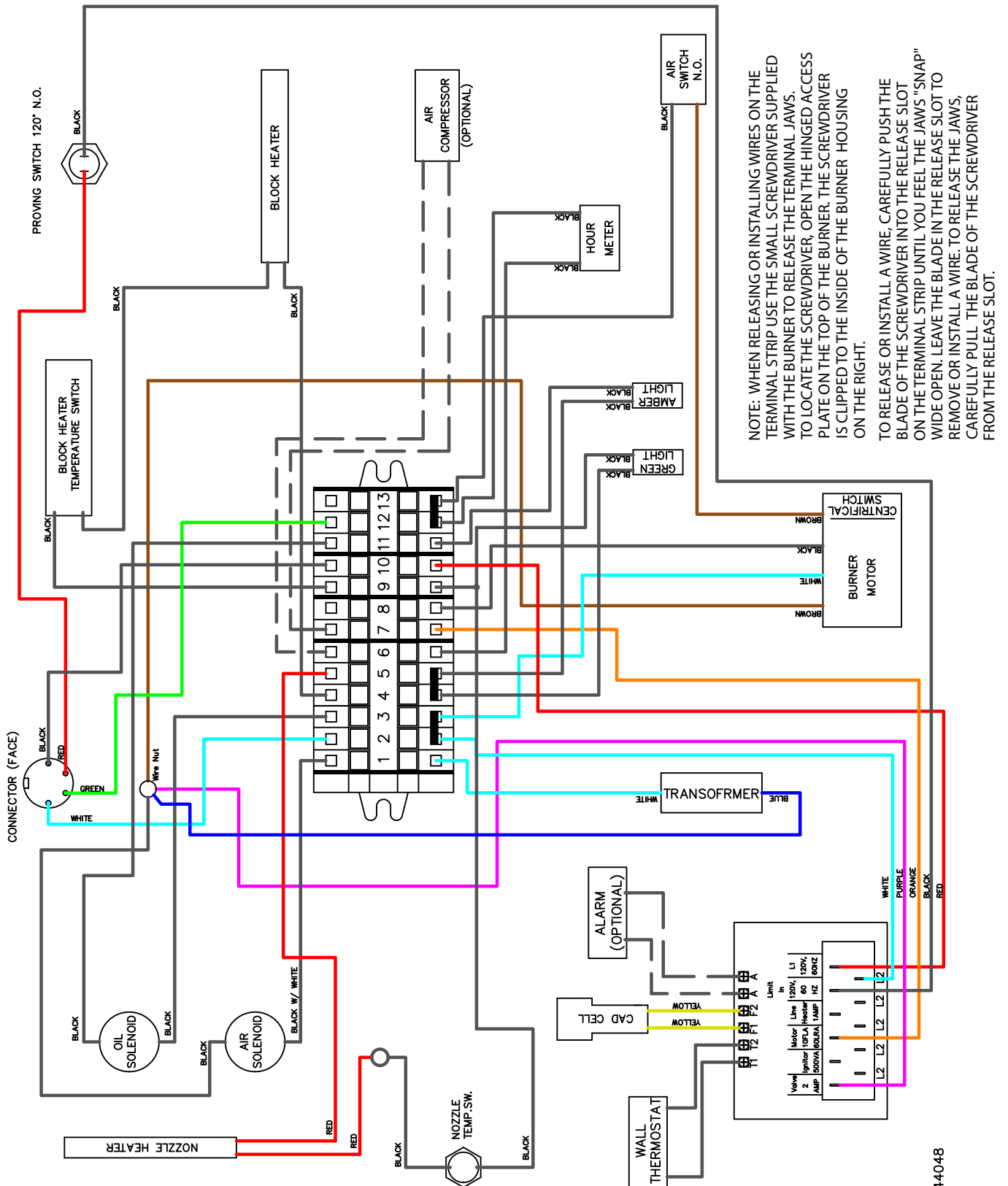
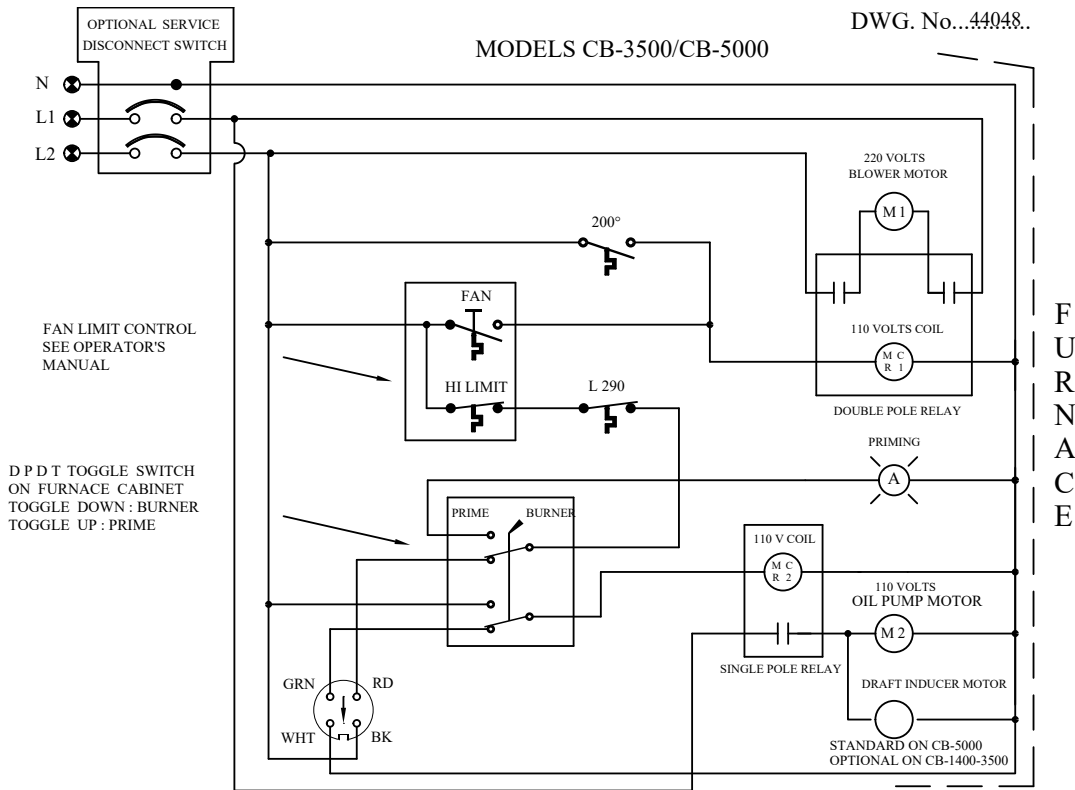

Figure B2 - CB-3500/CB-5000 with CB-500 Series Burner

4404B

MODELS CB-3500/CB-5000



⊗ - CONNECTION TO CUSTOMER POWER

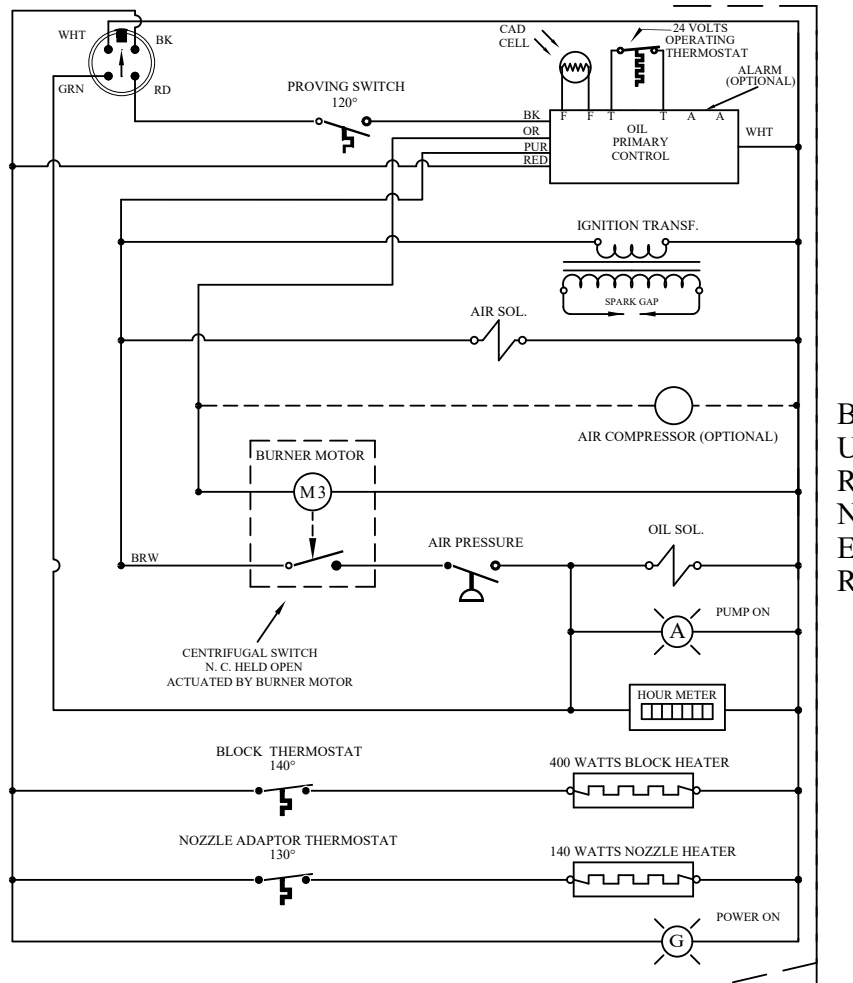

Figure B3 - Ladder Schematic for Models CB-3500/CB-5000 (220/240 Volts / 60 Hz)

Wiring Diagrams (continued)

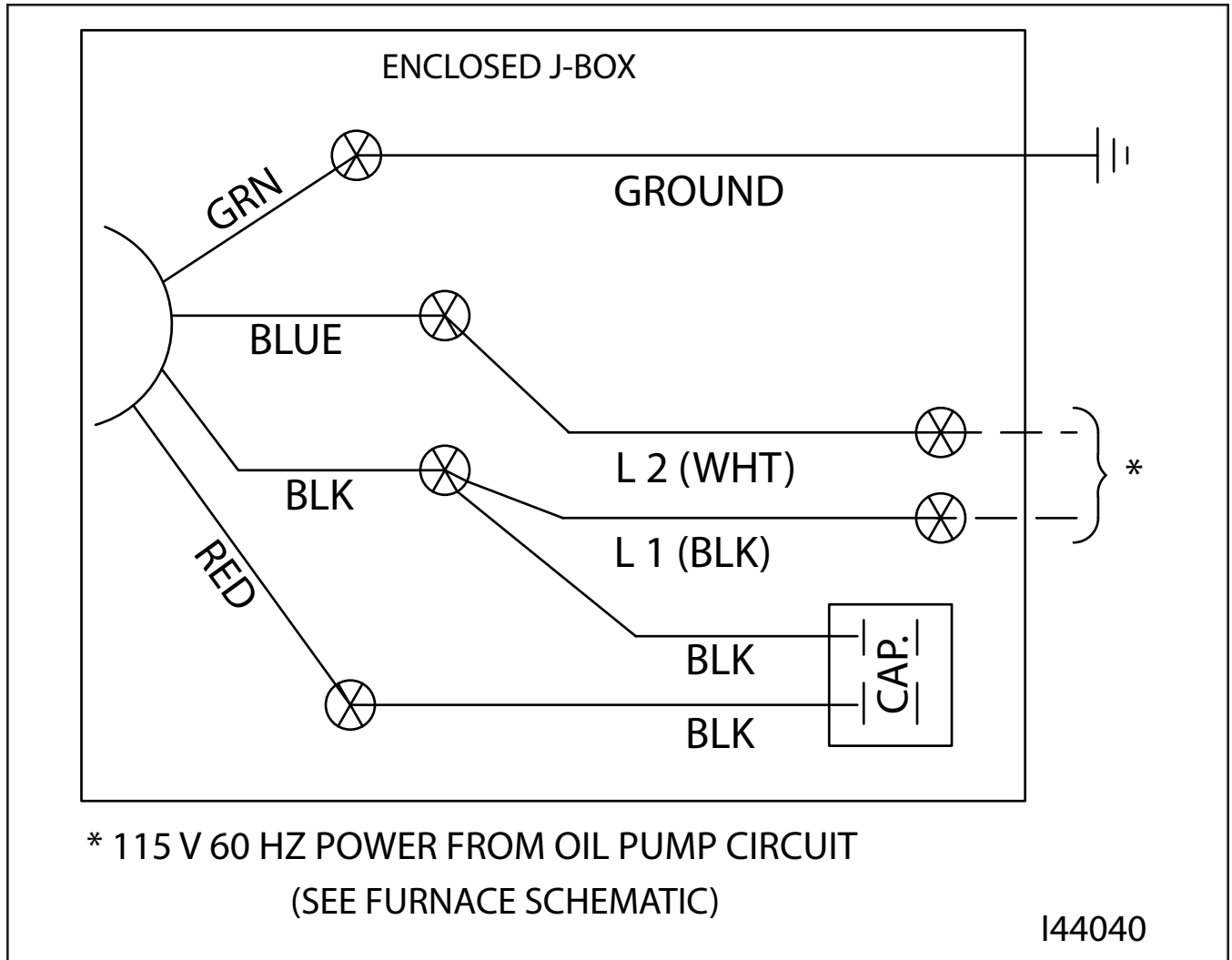

Figure B4 - Metering Pump Wiring Schematic

Understanding the Oil Primary Control

Model 33409 / 33165 Cad Cell Oil Primary Control Data Sheet



CLEAN BURN[®] Model 33409 / 33165 CAD Cell Oil Primary Control Data Sheet

- **Oil Pump Bleed Assist**
60 seconds
- **CAD Cell Resistance Monitoring Jack**
Works with any multimeter
- **Recycle on Flame Failure**
- **Serviceman Reset Protection**
Latch-up after 3 consecutive lockouts
- **Diagnostic LEDs**
Status, lockout, flame
- **15/30/15 Timing**
- **Increased Flame Accuracy**
- **Thermostat/Aquastat Compatible**
- **Improved SMC Technology**
Zero bleed voltage during standby
- **Works Well with Generators**
Insensitive to frequency changes
- **Early Spark Termination** (optional)
- **Alarm Contacts**
- **Flame Signal Test Jack**

Power input (red/white wire)	120 VAC, 60 HZ, 9VA
Limit circuit input (black wire)	120 VAC, 60 HZ
Motor load	10 FLA / 60 LRA
Ignitor load	120 VAC, 60 HZ, 500 VA
Valve load	120 VAC, 60 HZ, 2.0 A
Alarm contacts	24 V, AC/DC, 2A

Nozzle Line Heater	120 VAC, 60 HZ, 1 amp
Operating temperature limits	+32°F to +140°F
Storage temperature limits	-40°F to +185°F
Thermostat anticipator current	0.1 A, AC
CAD cell resistance (with flame)	R < 1500 OHMS
Agencies	UL recognized (US & Canada)

Installing and Wiring

⚠WARNING The primary control must be installed and serviced only by a qualified service technician.

1. Always disconnect power source before wiring to avoid electrical shock or damage to the control. All wiring must comply with applicable codes and ordinances.
2. Thermostat terminals (T-T) provide a current source. Never apply external power to these terminals under any circumstances.
3. Alarm terminals provide a 24 VAC/VDC-rated dry contact.

Mounting

- The control may be mounted on a 4" x 4" junction box in any convenient location on the burner, furnace or wall. The location must not exceed the ambient temperature limit, 140°F.

Wiring

- Wiring must comply with local and national electrical codes, and with the wiring diagram.
- Individual or bundled neutrals may be attached to any L2 terminal.

Field checks

1. **Safety timing (TFI) test** – Remove one CAD cell wire (F-F). Start burner. The control should lockout within the TFI time limit. Replace CAD cell wire.
2. **Flame failure test** – Start burner. After flame is established (after TFI period), close the oil supply hand valve. This will cause a flame failure sequence as described in the Startup & Operation section of this Data sheet. The control should recycle (restart after 65 seconds).
3. If control does not operate as described, check the wiring.

Startup & Operation

⚠WARNING Do not start the burner if the combustion chamber contains oil or oil vapor.

NOTICE Per UL requirements, the control will not turn on if the CAD cell senses flame during the self-test. If the CAD cell sees light (flame) at the beginning of a cycle, the control will remain in self-test mode until the CAD cell no longer senses light (flame). The amber LED will blink momentarily every 3 to 4 seconds and green LED will be on or flashing.

Diagnostic LEDs		
– Amber OFF	– Amber ON	– Amber FLASHING
– Green OFF	– Green ON	– Green FLASHING
– Red OFF	– Red ON	– Red FLASHING

SEE WIRING DIAGRAM ON NEXT PAGE

Understanding the Oil Primary Control (continued)

Model 33409 / 33165 Cad Cell Oil Primary Control Data Sheet

Wiring

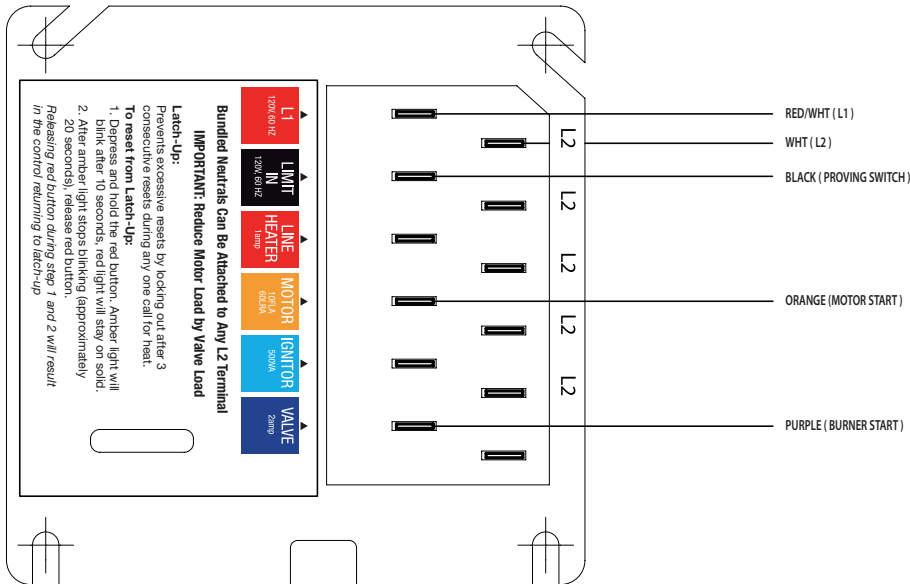

Startup & Operation (continued)

- ⓐ ⓑ Ⓒ Power ON** Open all manual oil line valves. Close the line switch. (If Red LED turns on constant **ⓐ**, control is in lock-out. See next page to reset.)
- ⓐ ⓑ Ⓒ Self-test 1** The control performs a “boot-up” test to verify internal operation each time power is applied to the L1 wire. The amber LED turns on and the test continues for about 5 seconds. If the test fails, the control turns the amber LED off and repeats this test sequence until successful.
- ⓐ ⓑ Ⓒ Stand-by** (No call for heat) If Self-test 1 is successful, amber LED turns off and control waits for heat call.
- ⓐ ⓑ Ⓒ Call for heat** Set thermostat to call for heat. Thermostat circuit must be closed and black wire must receive power from the limit circuit.
- Self-test 2** If a failure occurs in this self-check, the control won't start and the amber LED blinks 1 second on, 4 seconds off, until serviced or the problem clears. These failures include CAD cell seeing light, valve lead voltage on too early, internal fault, or line voltage <90 V. See service section.
- ⓐ ⓑ Ⓒ Burner on** After the self-test, amber LED turns off. The ignitor starts, followed 2 seconds later by the motor.
- ⓐ ⓑ Ⓒ Valve delay ON** The oil valve opens after the valve delay-on period (pre-purge). (For oil valve delay on operation, wire oil valve to the violet lead. If not using an oil valve, cap the violet lead to automatically disable pre-purge and post-purge).
- ⓐ ⓑ Ⓒ Pump Prime** To enter pump prime: 1. Start a CFH cycle. During Pre-Ignition or Valve Delay On, press Reset until motor turns off (10 seconds), then release the button. When motor turns back on, within 5 seconds, press the Reset button until the amber LED starts to flash. You are in Pump Prime, release Reset button.

Optional Pump Prime notes: 1) If lost, press Reset for 1 second and release, then if the control is not in Pump Prime, restart the sequence. 2) If Reset is released before end of first 10 seconds, the control returns to Standby and restarts another CFH cycle. 3) If reset is not pressed the second time, a normal CFH cycle will continue. 4) If motor and igniter are on and amber LED is flashing, the control is in Pump Prime. 5) Pump Prime will exit standby if flame is detected, or 60 seconds has elapsed, or loss of TT or Limit, or Reset button is pressed.

Understanding the Oil Primary Control (continued)

Model 33409 / 33165 Cad Cell Oil Primary Control Data Sheet

Startup & Operation (continued)

- Ⓐ Ⓒ Ⓓ **TFI** The CAD cell must sense flame within the TFI time limit (trial for ignition). Insufficient flame puts control into lockout.
- Ⓐ Ⓒ Ⓓ **Run** The burner continues firing during call for heat if the CAD cell is sensing flame. Only the green LED is on during normal running.
- Ⓐ Ⓒ Ⓓ **Lockout** If CAD cell does not sense flame within the TFI time limit after the burner starts, **lockout** occurs. The control turns the red LED on constant and closes the alarm contact.
- To Reset** Push in and hold reset button for 2 seconds, then release.
- NOTICE** The primary control will not reset from lockout if power is interrupted.
- Ⓐ Ⓒ Ⓓ **Flame failure** If the CAD cell loses flame signal during operation (after the TFI), the red LED flashes. The burner shuts off within 2 seconds. **Recycle:** Control waits for 65 seconds (with red LED flashing), then begins again at Self-test 2. Red LED goes off.
- Ⓐ Ⓒ Ⓓ **NOTICE** If the green LED is blinking during a run, the flame is weak or unstable which may cause recycle.
- Ⓐ Ⓒ Ⓓ **Motor delay OFF** Set thermostat (or Aquastat) to stop call for heat. The oil valve (if installed) will turn off within 2 seconds. The motor remains on for the motor delay off period (post-purge), then turns off. (If no oil valve is wired to the control, the burner shuts off within 2 seconds after end of call for heat. There is no post-purge.)
- Ⓐ Ⓒ Ⓓ **Stand-by** Control remains in stand-by mode until limit circuit sends power to the black wire and thermostat circuit closes (call for heat).

Understanding the Oil Primary Control (continued)

Model 33409 / 33165 Cad Cell Oil Primary Control Data Sheet

Service & Troubleshooting

Burner (control) will not come on

ⓐⓑⓓ No power to control

- Check limit circuit to the control (at least 102 VAC).
- Check all electrical connections.

ⓐⓑⓓ Control is in lockout

- Red LED will be on. Press the reset button for 2 seconds.

ⓐⓑⓓ CAD cell seeing light

- Green LED on, and amber LED blinking 1 second on, 4 seconds off. Remove one yellow lead from FF terminals, and the flame test plug.
- If the amber LED remains flashing and green LED on, the control is defective.
- If the amber and green LEDs go OFF, the control is OK, and;
- light is leaking into the burner housing, or
- CAD cell is defective, or
- There is a problem with the CAD cell wiring or holder.
- If appliance was recently shut down, CAD cell may see residual hot spots in chamber.

To troubleshoot:

- Check CAD cell by plugging a 3.5mm mono plug into the CAD jack after entering TFI, or before a call for heat (for dark chamber checks). Attach the plug to a multimeter to monitor CAD cell resistance. Dark resistance should be over 50K OHMS, and room light resistance (control flipped open) should be at most 10K OHMS. Replace cell if necessary, or reinstall and close the burner housing.

NOTICE Control will not start if the plug is inserted. Also, if the plug is inserted more than two minutes, the control goes to Standby.

- Check for stray light by measuring the CAD cell resistance looking into the inactive combustion chamber. It should read at least 50 kohms.

Other no-start problems

If the CAD cell is OK, and the amber LED still blinks 1 second on, 4 seconds off, the other possible failures include:

- Valve lead voltage on too early. *Correct bad connection.*
- Line voltage <90 VAC (amber LED flashes uniquely, 1 second on, 1/2 second off, 1 second on, 3 seconds off, then repeats).
- Internal fault. If valve has no voltage, and line voltage OK, the issue may be an internal fault. *Replace the control.*

NOTICE FROZEN PIPES/WATER DAMAGE: This is not a freeze protection device. Suitable freeze protection monitoring or other precautions are recommended to protect against ruptured pipes/water damage caused by fuel outage, safety related fault conditions, or equipment failures.

Repeated flame failures (ⓐⓑⓓ flashing red LED)

Check for:

- CAD cell is defective. *Replace.*
- Air leaking into oil line causing flame out. *Check oil line connections and filter gasket.*
- Defective nozzle causing flame to be erratic. *Change nozzle.*
- Excessive airflow or draft causing flame to leave burner head. *Check for proper air band setting and draft.*
- Excessive back pressure causing flame to be erratic. *Check appliance and flue for sooting/plugging.*

Control locks out after TFI (ⓐⓑⓓ red LED on)

Check for:

- No oil to burner. *Check oil supply, filters, lines.*
- Shorted electrodes. *Inspect for cracked porcelain and replace as needed.*
- Poor spark. Check electrode spacing and condition per burner manual. *Replace or realign if necessary.*
- Nozzle clogged. *Replace nozzle.*
- Airflow too high. *Check air band setting.*
- Ignitor module defective. *Replace if no spark.*
- CAD cell defective
- Oil valve (if used) stuck in closed position.
- Check wiring connections.

ⓐⓑⓓ Blinking Green LED

- Weak or unstable flame.
- Check ohms.
- Check CO₂ levels

APPENDIX C

Furnace Service Record

Furnace Purchased: Date _____ From (name/phone) _____

Furnace Installed: Date _____ By (name/phone) _____

Furnace Inspected: Date _____ By (name/phone) _____

Note: Refer to Section 9 for Maintenance Instructions

<u>Draft Readings</u> (Date / Draft)		<u>Service Record</u> (Date / Initials of Technician)						
Burner	Stack	Canister Filter	Metering Pump	Check Valve and Screen	Chamber & Flues	Stack	Oil Tank	A.P.M.*

*A.P.M. is Annual Preventative Maintenance on the Burner (Burner Tune-up)

