



LH100C8 INSTANT-PRIME® PUMP



■ PUMP SPECIFICATIONS

Pump End: GPS MCL-I458C
 Pump Size: 5x4 inches (125x100 mm)
 Max Flow: 1300 US GPM (305 m³/h)
 Max Head: 160 feet (49 m)
 Solids Size: 1 inches (25.4 mm)
 Mechanical Seal: Single mechanical seal 1.875"
 Lip Seals: CR type, single lip, Buna-N (Bearing & SAE Cover) and Viton(Stuffing box)
 Non-Drive End Bearing: Single row ball bearing 6310
 Drive End Bearing: Single row ball bearing 6410
 Air/Water Chamber: Steel material and designed to separate air and water before entering into vacuum pump suction hose.
 Discharge Non Return Valve: Swing type, cast iron with Buna-N disc (Viton optional)
 Gasket: Aramid Fiber w/ EPDM
 O Ring: Buna-N

■ VACUUM ASSISTED PRIMING SYSTEM

INSTANT-PRIME® SYSTEM: Patent Pending self priming pumps are equipped with the most powerful priming system and P-S-P mechanism. Instant-Prime® pump sets a new benchmark of vacuum assisted priming pumps in the industry.

VACUUM PUMP DATA*: Air Capacity: 112CFM
 Vacuum: -26inHg(9m)

* at engine speed 2200 rpm

■ PUMP FEATURES

1 ECO Friendly Vacuum Priming System

GPS pump's EVP self priming system has extraordinary features like large air process capability, high vacuum, low operation temperature, maintenance free, oil and mechanical seal free etc.

2 P-S-P Auto Switch System (Prime-Sleep-Prime)

EVP system will be switched to sleep status automatically once priming was finished. When it is used for general purpose application, EVP system only operates for a few seconds for priming, which makes it almost unnecessary for daily maintenance or changing spare parts within its life cycle.

3 Dry Running Protection System

Instant-Prime® pumps offer three types of dry running seal options: oil reservoir lubricated mechanical seal, air cushion protected mechanical seal and grease lubricated lip seals configurations. Either of them can secure the pump run dry for a long time.

4 Cooling System**

A pressurized cooling flush water is introduced from centrifugal pump into vacuum pump's water jacket and then flows back to centrifugal pump. This cooling system cools the vacuum pump quickly and brings most of the heat out of the vacuum pump's cavity, and makes its rotor has an extraordinary long life.

5 Easy Maintenance Structure

It is very convenient to remove the vacuum pump's cover from its non-drive end, and slides can be easily pulled out for inspection or replacement. It is also easy to access to the centrifugal pump's impeller, wear ring or mechanical seal for inspection or maintenance without removing diesel engine or pump's frame since the centrifugal pump's suction cover can be fully opened.

6 All-In-One Pump Applications

EVP Priming system's powerful function makes Instant-Prime® pumps can be used in almost all aspects of fluid industry, including well point dewatering. Buy one pump and get all your jobs covered.

** cooling system is only needed for well point dewatering application.

■ ENGINE SPECIFICATIONS

Engine Model: DEUTZ D2.9L4
 Rated Power At Speed: 50HP @ 2600RPM
 Engine Type: Water-cooled 4-cylinder inline engine with cooled, external exhaust gas recirculation with and without turbocharging and optionally with and without charge air cooling.

Displacement: 177 Cu.In. (2.9 Liters)
 EPA Tier: Tier 4 Final/Stage V
 Fuel Tank: 65 U.S. Gallons (245 Liters)
 Full Load Operating Time: 26.3 Hours
 Starter: 12 Volts Electric
 Control Panel: Murphy, Controls Inc, Deepsea, Kensho, Lofa

■ PUMP MATERIAL OF CONSTRUCTION

Main Parts	Standard (code:38)	Optional 1 (code:58)	Optional 2 (code:88)	Optional 3 (code:98)
Impeller	CA6NMSS	CA6NMSS	26% High Chrome	CD4MCu
Shaft	17-4PH	17-4PH	17-4PH	17-4PH
Wear Ring	Gray Iron	Gray Iron	Carbon Steel	316SS
Suction Cover	Gray Iron	Ductile Iron	26% High Chrome	CD4MCu
Volute	Gray Iron	Ductile Iron	26% High Chrome	CD4MCu
Stuffing Box	Gray Iron	Ductile Iron	26% High Chrome	CD4MCu
Adaptor	Ductile Iron	Ductile Iron	Ductile Iron	Ductile Iron



INSTANT-PRIME® Pumps. Patent Pending.

LH100C8 INSTANT-PRIME® PUMP DIMENSIONS

TRAILER MOUNTED
NET WEIGHT: 3681 LBS. (1670 KG.)
SHIPPING WEIGHT: 4122 LBS. (1870 KG.)

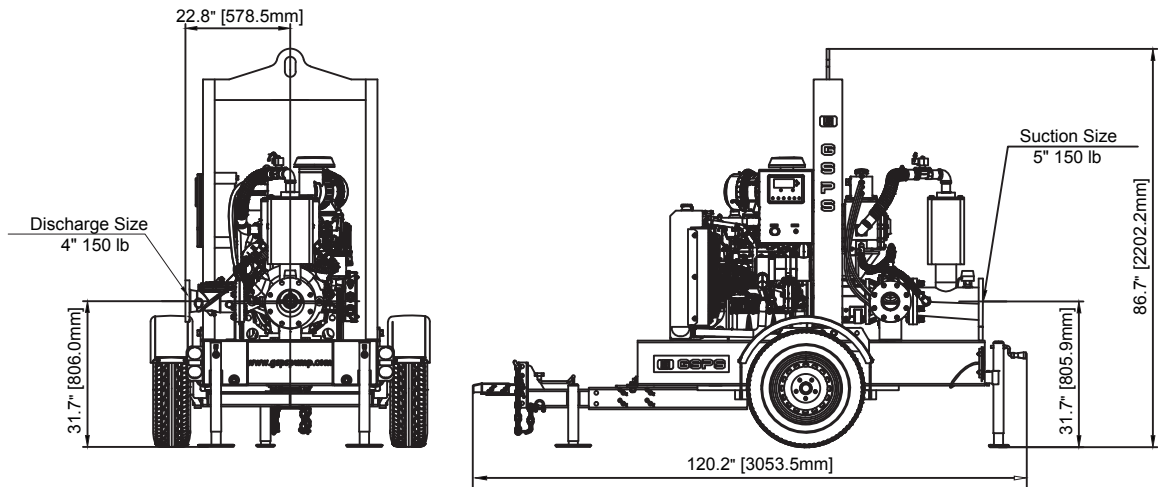

LH100C8 INSTANT-PRIME® PUMP PERFORMANCE CURVE

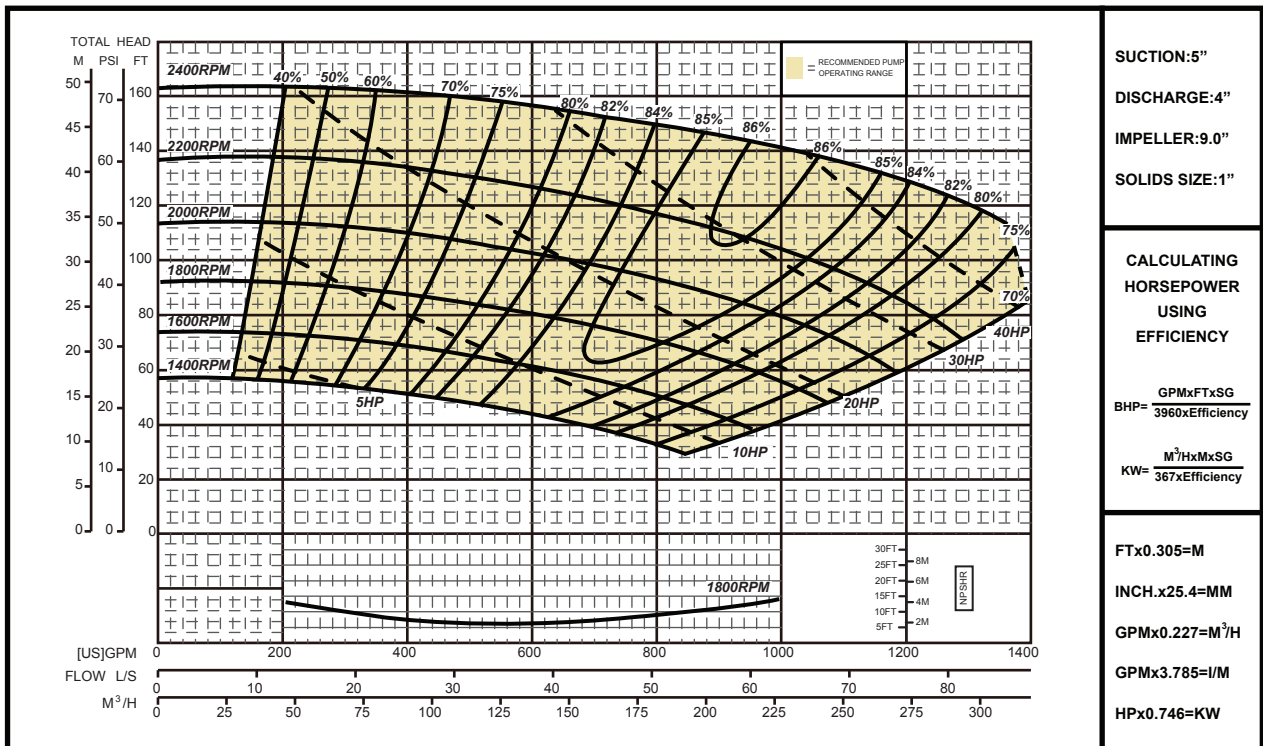

PUMP DESIGNATION SYSTEM

Pump Type
 LH: Low Head Pump
 MH: Medium Head Pump
 HH: High Head Pump

Pump Inlet & Outlet
 LH: Pump Outlet Size (mm)
 MH: Pump Outlet Size (mm)
 HH: Pump Inlet Size (mm)

Impeller Type
 S: Solids Handling
 C: Clear Water

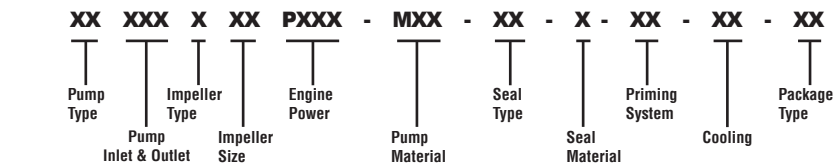

Impeller Size: Inch
Engine Power: hp

Pump Material
 38: Standard
 58: Optional 1
 88: Optional 2
 98: Optional 3

Seal Type
 MO: Mech. Seal Oil Lub (Standard)
 MA: Mech. Seal Air Cushion
 LG: Lip Seal Grease Lub

Seal Material
 1: SiC/SiC (Standard)
 2: TC/SiC
 3: TC/TC
 4: NBR
 5: Viton

Priming System
 V1: Venturi
 V2: Diaphragm Pump (NA)
 V3: EVP (Standard)

Cooling
 WC: With Cooling System
 NC: No Cooling System

Package Type
 SO: Skid Open
 TO: Trailer Open
 SE: Skid Enclosed
 TE: Trailer Enclosed
 SP: Skid Push Bar
 GN: Goose Neck