

# Aeras

UTILITY

## Ramvac

*THE SMART WAY  
TO POWER YOUR PRACTICE*



# Aeras

## *INTELLIGENT AERAS™ TECHNOLOGY*

In an increasingly complex world, smart devices simplify the intersection between technology and life. From the evolution of the smartphone to the smart home revolution, smart is simplifying the way we live, streamlining the way we work and enhancing the way we play. This interconnectivity gives us unmatched control over our environment.

## *GIVING A VOICE TO THE TOOLS OF THE TRADE*

When the tools of your trade can communicate with each other, that's smart. When they can communicate with you, that's Aeras. The new Aeras platform from DentalEZ can collect data, share information and streamline standard-of-care processes, creating an environment of patient care and practice efficiency that will revolutionize the way you interact with your dental office.



Feel confident knowing your utility equipment can be **monitored & protected** around the clock<sup>1</sup>



Service provider can view up to **six months of data** to help diagnose potential issues<sup>1</sup>

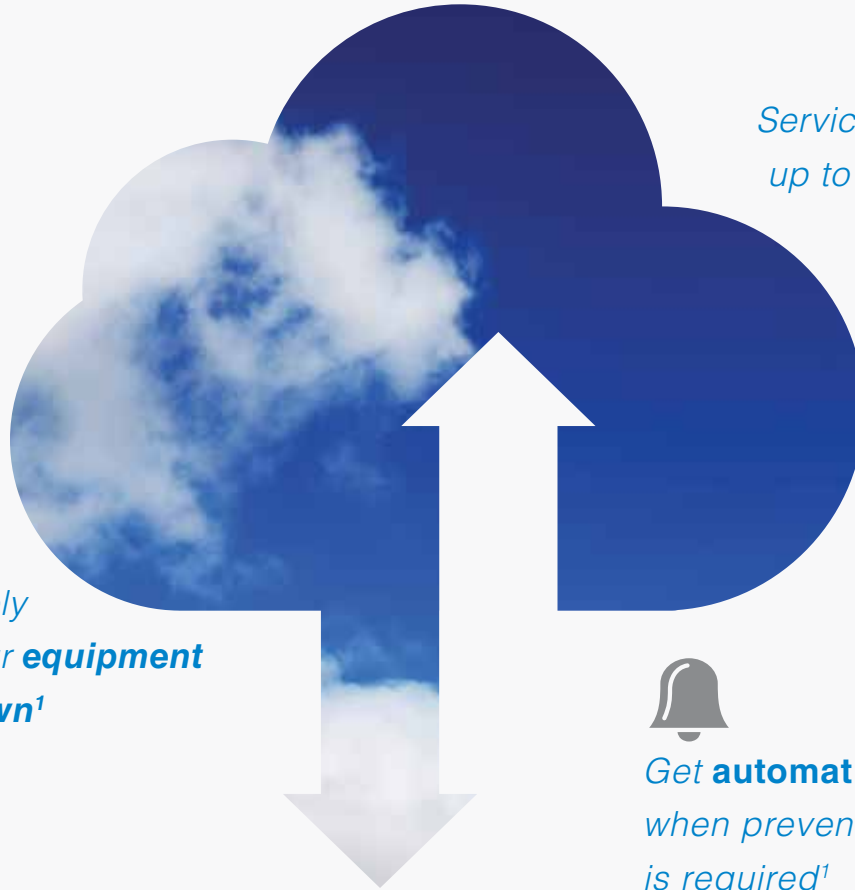

**Schedule** remotely exactly when your **equipment powers up & down**<sup>1</sup>



Get **automatic notification** when preventive maintenance is required<sup>1</sup>



**8-Year** optional extended warranty\*

## INTELLIGENT UTILITY THAT MONITORS & COMMUNICATES

\*Terms apply

<sup>1</sup>Applies only if subscribing to monitoring service

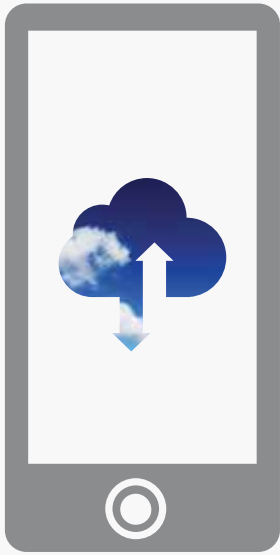

*STAY INFORMED*



*24/7*



*PEAK EFFICIENCY*



*SAVE*

## *MONITORING 24/7*

Aeras cloud-based technology collects data, shares information and streamlines mechanical diagnostic processes, allowing for a data connection between the dental practice and local dealer. The embedded sensors can reach out to a technician and share the diagnostic data it's generating, enabling the Aeras system to head off potential problems before they become problematic. **Plus, Aeras is protected with an 8-year optional extended warranty, the best in the industry.\***

# COMBAT THE HIGH COST OF DOWNTIME



## INCOME

On average, general practices are bringing in \$771,000 in annual revenue and specialists are bringing in \$1.1 million<sup>1</sup>



## OVERHEAD

Since 2005, revenue has been increasing and Dentist income has been declining due to increased overhead costs<sup>1</sup>

The Aeras technological platform creates significant economic value by reducing risk of service interruptions and increasing maintenance efficiency.\*

\*Applies only if subscribing to monitoring service

<sup>1</sup> DentalEconomics.com- [http://digital.dentaleconomics.com/dentaleconomics/201508?sub\\_id=mJbori6VKUCU&pg=20#pg20](http://digital.dentaleconomics.com/dentaleconomics/201508?sub_id=mJbori6VKUCU&pg=20#pg20)



## *DOWNTIME*

Downtime increases risk of losing patients. One day of downtime = \$2,954 - \$4,214<sup>2</sup>



## *LOSS*

An average practice loses 15% of its patients per year<sup>2</sup> This can translate to a conservative estimate of \$2 million in lost revenue over the course of a typical dentist's 30-year career<sup>2</sup>

Every moment of downtime means lost revenue. Aeras can keep your practice up and running by reducing risk of mechanical problems that bring productivity to a screeching halt.

<sup>2</sup> DenistryToday.com - <https://www.dentistrytoday.com/news/todays-dental-news/item/3204-are-you-losing-patience-with-losing-patients-if-you-are-you-re-not-alone>



## *2 WAY COMMUNICATION*

A stress-free environment where your energy is focused on solving the problems of the patient offers the most productive way to practice. By providing critical information to help prevent a back-office breakdown, Aeras can dramatically\* enhance the treatment journey for the patient and the clinicians alike. It puts the full power of interconnected information sharing to work for the good of the practice and the patient.

**Notifications** *via email or text when maintenance is required.*

**Power equipment up & power down** *remotely from any location.*

**Schedule** *when your equipment turns on/off to save energy.*

*WITH THE AERAS GUARDING YOUR  
BACK-OFFICE UTILITY YOU CAN ENJOY YOUR DAILY PRACTICE  
WITH LESS STRESS & OVERALL PEACE OF MIND*



A woman with long dark hair is reclined in a dental chair, smiling broadly. In the background, two dental professionals in white coats and blue masks are working. The scene is brightly lit, creating a warm and professional atmosphere.

*PRACTICE FIRST =  
PEACE OF MIND*

THE HEART OF  
THE PRACTICE WITH  
A MIND TO MATCH

Aeras  
Ramvac



## *AERAS FROM RAMVAC®*

The Aeras from Ramvac is a machine of two minds. First, it's a no-nonsense workhorse that's serious about keeping the practice powered up, day in and day out. But it also has a sensitive side, letting those around it know about any little problems it's having before they become problematic. Aeras technology brings these two sides of Ramvac together to keep your practice of sound mind and body. It's part of a smart ecosystem of in-practice tools that will protect against loss, enhance productivity and deliver the utmost in reliability.

*FOR ANY PRACTICE LOOKING TO INCREASE PRODUCTIVITY & DECREASE DOWNTIME, AERAS FROM RAMVAC IS YOUR NUMBER ONE CHOICE.\**

## *RAMVAC RELIABILITY*

Compressors are complex, mission-critical machines that are essential to every practice. Powering the most frequently used systems including handpieces, scalers, chair valves and even cutting and milling stations, it is the workhorse in the practice, until it stops working. When the compressor goes down, the practice goes with it. That's why reliability is so important when it comes to your compressor.

With a legacy of reliability, Ramvac compressors have earned the trust of the profession. By empowering technicians to access the unit remotely, Aeras from Ramvac lets you avoid unnecessary (and costly) service trips while keeping your practice is up and running. In doing so, it gives you a level of assurance that other systems cannot match.

\*Applies only if subscribing to monitoring service

# A PRACTICE OF SOUND MIND AND BODY.

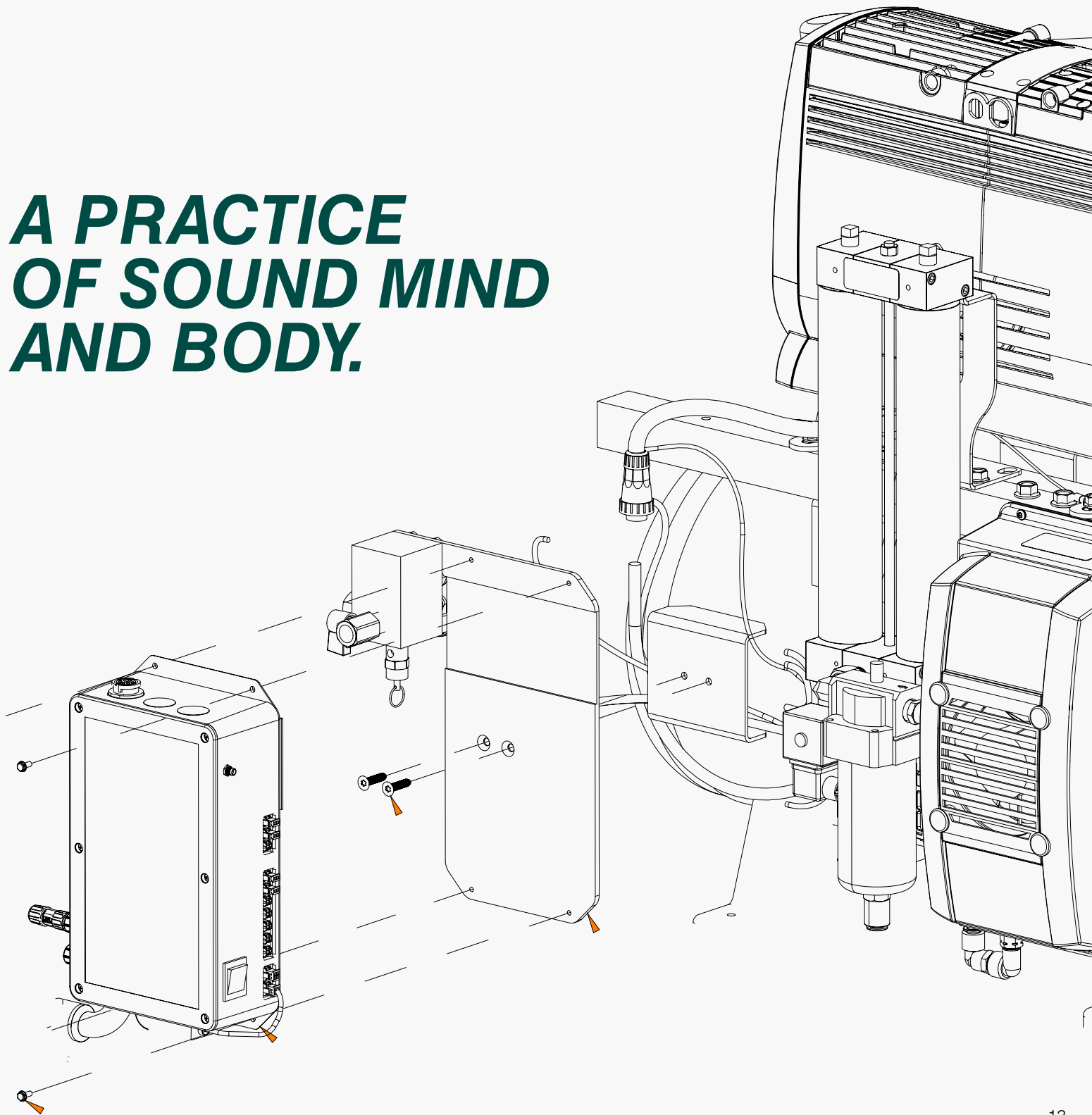





*RAMVAC STANDARD FEATURES  
THAT WILL MAKE YOU SMILE*

## *DUAL DESICCANT DRYER TECHNOLOGY*

The Aeras dual desiccant setup produces a continuous supply of clean air to power your practice. The system automatically toggles between the chambers as needed to provide a continuous supply of air while purging moisture from the chamber.

*100% duty cycle*

*Prevents bacterial growth by storing air at a dew point of -40°*

*No antimicrobial lining required*

*Easy to replace desiccant cartridges*

## *ROCKING PISTON DESIGN*

Our unique rocking-piston design delivers the quiet confidence of consistency. It cuts the ambient compressor noise while doubling the life of the compression rings compared to standard piston design. It has the added benefit of reducing friction, producing the same power while operating at lower temperatures

## *HIGH-PRESSURE FOR MILLING MACHINES*

Practices that run a milling machine know the importance of high pressure. Aeras makes it easy to toggle between standard and high-pressure with our on-board control system.



Fig.1

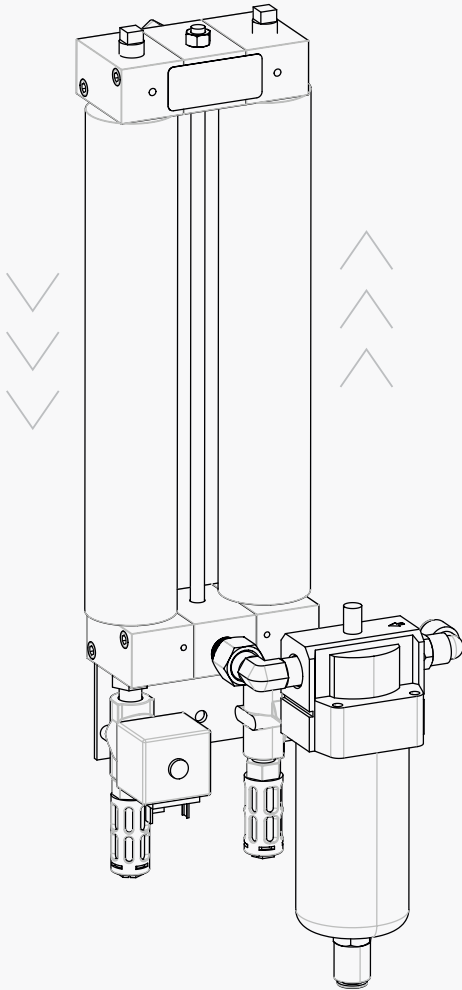

Fig.2

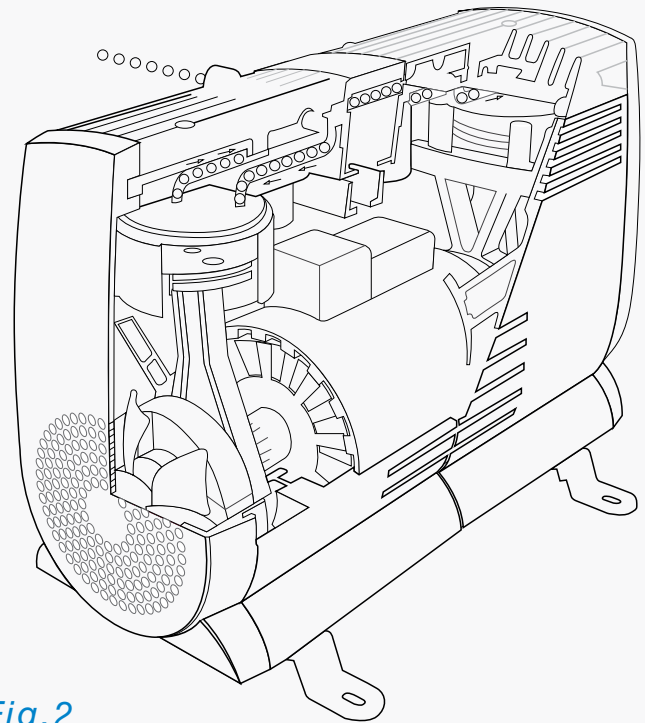

Fig.1 Dual Desiccant Dryer Technology  
Fig.2 Rocking Piston Design

## *ON BOARD SENSORS*

The onboard sensors actively monitor PSI, ambient room temperature, tank temperature, humidity, motor temperature and head voltage. These sensors will notify the user when preventive maintenance may be required in order to prevent a costly back-office shutdown.\*

\*Applies only if subscribing to monitoring service

# THE SENSORS

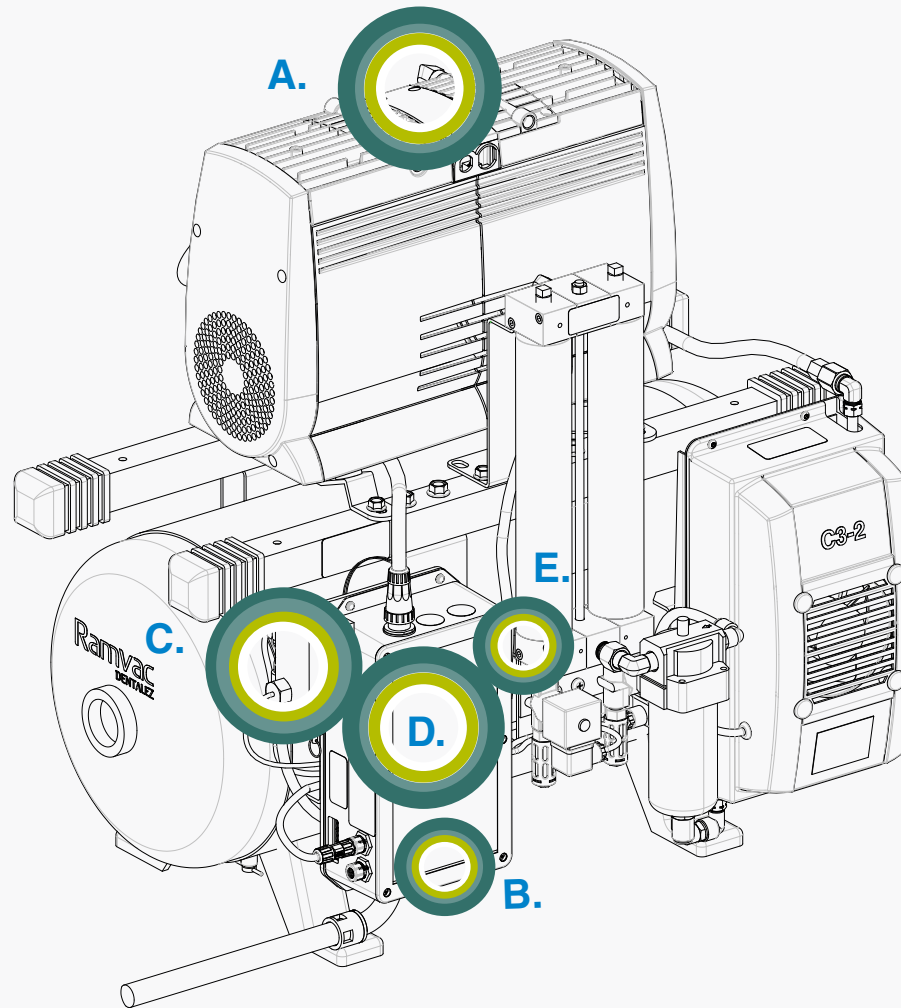

**A. The motor head temperature** sensor monitors the temperature and warns the user prior to thermal shutoff.

**B. The ambient temperature** sensor verifies that the room temperature and humidity are in range for the compressor.

**C. Tank pressure** sensor monitors the PSI or air pressure of the tank. The sensors to track temperature and humidity of the tank air are used to calculate the dew point and help determine the efficiency of the pre-cooler and dry tower.

**D. Both the building voltage and the power draw** per head detect spikes and subsequent faults to assist with technical troubleshooting.

**E. All data** collected from the on-board sensors are transmitted via a **cellular antenna**

# THE ECOSYSTEM

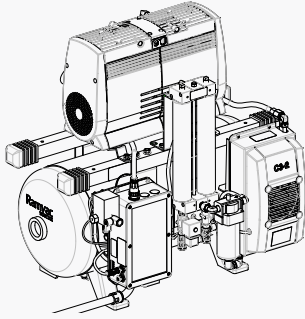

COMPRESSOR >>> CLOUD >>> DEVICE

## COMPRESSOR PERFORMANCE DETAIL\*

Offers comprehensive performance and activity history for the device from the onboard sensors.

## SCHEDULING FUNCTIONALITY\*

Schedule when the utility equipment turns on and off throughout the day. Smart scheduling senses activity, preventing shutdown for procedures that run late.

## NOTIFICATIONS\*

Customize email and /or text message notifications for alerts or maintenance reminders.

\*Applies only if subscribing to monitoring service

## COMPRESSOR PERFORMANCE DETAIL

Scheduling Admin

Search equipment...

Dr. Rick Fowler

### COMPRESSOR-01 Offline

North Hills Family Dentistry - Workford Plaza Get Latest Service Data

**Performance**

Pressure Drop (PSI)	Run Hours	Head Stage	Head Duty Cycle
-44.4F	10hrs	---	---

**Compressor Sensors** See Logs > Sensor History

Tank Pressure	Tank Temperature	Tank Humidity	Ambient Temperature	Ambient Humidity	Voltage Line
82.9psi	72.6F	0.5%	71.1F	17.7%	248.1V

**Motor Health**

Motor 1 Temp	Motor 1 Error	Motor 1 Runtime	Motor 2 Temp	Motor 2 Error	Motor 2 Runtime
73F	0W	1367hrs	71.5F	0W	10hrs

**Active Alerts**

Date	Type	Sensor	Message	Clear
Sep 26 2019 11:08 am	Motor Start Upper Bound	Motor 2 Temp	⚠ Please monitor equipment	🟢

[View Alert History](#)

**Maintenance Reminders**

Service Due	Hours	Last Serviced	
Replace Air Intake Filter	22 hours remaining	Sep 26 2019 12:08 am	➕ Add Service Record
Replace Coalescing Filter	2 hours overdue	Sep 26 2019 12:08 am	➕ Add Service Record

**Service Records** ➕ Add Service Record

Date	Serviced By	Summary	Services
Oct 10th 2019	Rich	Replace Air Intake Filter	1
Oct 8th 2019	Bruce	Replace Coalescing Filter, Replace Compressor Desiccant Filters	2
Oct 7th 2019	Doney	Replace Air Intake Filter, Replace Coalescing Filter	3
Oct 7th 2019	Doney	Replace Motor 1, Replace Motor 2	2
Oct 9th 2019	Doney	Compressor General, Replace Coalescing Filter, Replace Air Intake Filter, Replace Compressor Desiccant Filters	4

© 2019 ServiceZ. All rights reserved. Aeras

## ELECTRICAL REQUIREMENTS

Model Number	Description	Voltage	Amps	Breaker Size	Total HP
C3-2	Aeras 3 Compressor	230V	10.5	20 amp	2
C4-1	Aeras 4 Compressor	115V	23	30 amp	2.5
C4-2	Aeras 4 Compressor	230V	11.5	20 amp	2.5
C6-2	Aeras 6 Compressor	230V	16.3	20 amp	3.25
C7-2	Aeras 7 Compressor	230V	21	30 amp	4
C11-2	Aeras 11 Compressor	230V	32	40 amp	6

## WEIGHT AND DIMENSIONS

Model Number	Description	Weight (lbs)	Dimensions W x D x H (in)	Dimensions w Sound Cover	Tank Size (Gallon)
C3-2	Aeras 3 Compressor	160	29" x 21" x 29"	33.3" x 29" x 34"	12
C4-1	Aeras 4 Compressor	190	29" x 21" x 29"	33.3" x 29" x 34"	12
C4-2	Aeras 4 Compressor	190	29" x 21" x 29"	33.3" x 29" x 34"	12
C6-2	Aeras 6 Compressor	250	35" x 25" x 30"	35" x 29" x 34"	20
C7-2	Aeras 7 Compressor	260	35" x 25" x 30"	35" x 29" x 34"	20
C11-2	Aeras 11 Compressor	385	41" x 29" x 32"	41.1" x 33" x 36"	30

## SIZING GUIDE

Model Number	Description	Number of Users	Number of Heads	Peak Airflow Output @ 80 PSI (CFM)	Sound Covers
C3-2	Aeras 3 Compressor	3	1	6.0	8543-022
C4-1	Aeras 4 Compressor	4	2	6.6	8543-021
C4-2	Aeras 4 Compressor	4	2	6.6	8543-022
C6-2	Aeras 6 Compressor	6	2	9.3	8543-023
C7-2	Aeras 7 Compressor	7	2	12.0	8543-023
C11-2	Aeras 11 Compressor	11	3	18.1	8543-024

## LIMITED WARRANTY

DentalEZ and its employees are proud of the products we provide to the dental community. We stand behind these products with a warranty against defects in material and workmanship as provided below and have our own in-house repair facility to service our products. In the event that you experience difficulty with the application or operation of any of our products, please contact our customer service department at our expense at (866) DTE-INFO.

If we cannot resolve the issue by telephone, we will arrange for a representative to contact you or suggest that the product be returned to our factory for inspection.

If product return or repair is required, we will provide you with a Return Authorization number and shipping instructions to return the product to the proper facility. If the product is under warranty, we will ask you to provide proof of purchase such as a copy of your invoice. Please be sure to include the Return Authorization number on the package you are returning. Products returned without a return authorization number cannot be repaired.

Freight costs for product returns are the responsibility of the customer. Products under warranty will be repaired or replaced, at our sole discretion, and returned at our expense. Products outside the warranty limits will be repaired and returned with costs invoiced to the customer. We are not responsible for shipping damages. We will, however, help you file a claim with the freight carrier. Written repair estimates are available.

## SCOPE OF WARRANTY

DentalEZ warrants all Aeras Compressors to be free of defects in material and workmanship, under normal usage and service. DentalEZ' obligations under this warranty is limited to the repair or replacement, at our option, of the defective parts which are reported to DentalEZ during the applicable warranty period.

### APPLICABLE WARRANTY PERIOD

Aeras Compressors 6 years/4,200 hours (whichever comes first) from date of installation

Aeras Compressors with Aeras Smart Monitoring Service 8 years from date of installation provided the following additional terms applicable to this 2 year extended warranty are met:

- Aeras Smart Monitoring Service must be continuously maintained throughout the eight (8) year warranty period
- Aeras Compressor must be serviced and maintained by DentalEZ or by an authorized DentalEZ dealer in accordance with DentalEZ' maintenance schedule and as provided in the manual
- Only genuine Ramvac parts are used for all repairs and maintenance

### EXCLUSIONS

- This warranty covers manufacturing defects only and does not cover defects resulting from abuse, negligence, alterations, accidents, misuse, improper handling, cleaning, care or maintenance. Damage resulting from the use of chemicals, cleaners, disinfectants [or sterilization] is not covered under this warranty nor is normal wear and tear. Failure to follow or observe our operating/use, maintenance and/or installation instructions voids this warranty as does [installation or other work performed by anyone other than DentalEZ or its authorized dealers] the use of non-authorized parts and repairs made by an unauthorized repair facility.

## EXCLUSIVE REMEDY

Liability is limited to repair or replacement of the defective part(s) or products at our sole discretion. All other liabilities, in particular liability for damages, including, without limitation, special, exemplary, consequential or incidental damages are excluded and DentalEZ shall not be liable for loss of profits or loss of use.

## AUTHORIZATION

**THIS WARRANTY IS DENTALEZ' ONLY WARRANTY AND IS IN LIEU OF ALL OTHER WARRANTIES, EXPRESS OR IMPLIED, INCLUDING ANY IMPLIED WARRANTIES OF MERCHANTABILITY OR FITNESS FOR A PARTICULAR PURPOSE. NO EMPLOYEE, REPRESENTATIVE OR DEALER IS AUTHORIZED TO CHANGE THIS WARRANTY IN ANY WAY OR TO GRANT ANY OTHER WARRANTY.**

## WARRANTY REPAIRS

Parts repaired or replaced on a product that is in warranty will be warranted for the duration of that product's original warranty.

# DENTALEZ

2 West Liberty Blvd. Suite 160, Malvern, PA 19355  
dentalez.com | (866) 383-4636

© 2020 DentaleZ, Inc.

DentaleZ is a registered trademark and Aeras is a trademark of DentaleZ, Inc.  
Ramvac is a registered trademark of Ramvac Dental Products, Inc.