

The contents of this Addendum alter and amend the drawings and specifications and take precedence over the related items therein. Bidders shall include the cost of all items in their Bids.

GENERAL INFORMATION

1. Pre-Bid meeting minutes and Sign-In Sheet, dated July 31,2024, 8 pages, is attached to and made part of this addendum.
2. Addendum No. 1 was revised to include supplemental drawings SD-001 and SD-002.

SPECIFICATIONS

1. **Section 001116 – INVITATION TO BID**, Page 001116-2, Paragraph 1.3.A; **REVISE** bid date to **August 19, 2024**. All other information remains the same.

DRAWINGS

1. **Sheet A-001: MODIFY** DEMOLITION NOTES, Note No. 14, remove the reference to “structural drawings”.
2. **Sheet A-102: Drawing 1: MODIFY** slab repair plan to include dimensions for the repair area. See attached SD-001, which is attached to and made part of this addendum.
3. **Sheet A-102: Drawing 2: REMOVE** 3’-0” dimension and replace with SEE PLAN.
4. **Sheet A-103: Drawing 1 and 2: ADD** keynote 9.92.03 to Toilet Rooms 106, 106, and 107.
5. **Sheet A-103: Drawings 3 thru 12: REPLACE** keynote 9.30.10 with keynote 9.30.02.
6. **Sheet A-105: MODIFY** General Door Notes, Note No.3, to read as follows: UNLESS OTHERWISE NOTED, ALL DOORS SHALL BE PREFINISHED, REFER TO SPECIFICATIONS.
7. **Sheet A-106: Drawing 1: MODIFY** reflected ceiling plan to show area of ceiling to be carefully removed and reinstalled by General Contractor. See attached SD-002, which is attached to and made part of this addendum.
8. **Sheet A-110: MODIFY** Note to Bidder to read as follows: ALL WORK SHOWN ON THIS SHEET IS ASSOCIATED WITH ALTERNATE NO. 1 UNLESS NOTED OTHERWISE.
9. **Sheet A-110: Drawing 4: MODIFY** drawing title to read as follows: OH DOOR OPENING DETAIL.
10. **Sheet A-121: ADD** general sheet note: TAPERED INSULATION PLAN IS BEING PROVIDED FOR INFORMATION ONLY. CONTRACTOR TO PREPARE A TAPERD ROOF INSULATION PLAN UNDER THE SUPERVISION OF THE ROOF MANUFACTURE.
11. **All Sheets: MODIFY** keynote 8.36.01 to read as follows: NEW 10’X10’ OVERHEAD DOOR.
12. **All Sheets: MODIFY** keynote 10.44.22 to read as follows: PROVIDE NEW RECESSED FIRE EXTINGUISHER AND CABINET.
13. **All Sheets: MODIFY** keynote 9.30.02 to read as follows: WALL TILE ON ALL WALLS IN ROOM, UNLESS SPECIFIC WALLS NOTED OTHERWISE. COORDINATE WALL TILE EXTENS AND SIZES WITH ELEVATIONS.
14. **All Sheets: MODIFY** keynote 7.56.01 to read as follows: ELASTOMERIC COATING SYSTEM OVER ENTIRE EXISTING BARREL VAULT ROOF.

ADDENDUM NO. 1 - REV

August 2, 2024

PAGE 2

15. **All Sheets: ADD** keynote 9.92.03 to read as follows: PREP, PRIME, AND PAINT (2 COATS) ALL WALLSTHROUGHOUT SPACE UNLESS NOTED OTHERWISE. PAINT PARTITION FROM TOP OF WALL TILE TO 6" ABOVE CEILING GRID.

END.

MUHLENBERG GREENE ARCHITECTS, LTD.

JAS/lev

Attachments

- Pre-Bid Meeting Minutes and Sign-in Sheet, dated July 31, 2024, 8 pages
- SD-001, SLAB REPAIR PLAN, dated 8/2/2024
- SD-002, REFLECTED CEILING PLAN, dated 8/2/2024.
- RFI Responses:
 - Balton; RFI 01 thru 03
 - H&P; RFI 01
 - Uhrig; RFI 01 and 02
 - Purcell; RFI 01

In Attendance:

Zackary Tempesco, Airport Director
Mike Laity, Director of Operations
Ken Shadursky, FBO Manager
James A. Sarro, AIA
Grace Cai, AIA

Reading Regional Airport (RRA)
Reading Regional Airport (RRA)
Reading Regional Airport (RRA)
Muhlenberg Greene Architects, Ltd. (MGA)
Muhlenberg Greene Architects, Ltd. (MGA)

Other Attendees as per Sign-In Sheet

Distribution (Via Addendum No. 1):

The following minutes are intended to provide a summary of the issues and topics discussed relevant to the Pre-Bid Conference for the Multiple Building Renovations project for the Reading Regional Airport. All attendees are requested to review the information and notify Muhlenberg Greene Architects of any needed corrections or additions to these minutes. These Pre-Bid Meeting Minutes have been attached to Addendum #1 for the referenced Project and are to be considered part of the Bidding Documents.

Respectfully submitted,

MUHLENBERG GREENE ARCHITECTS, LTD.



James A. Sarro, AIA, LEED AP
Principal

JAS/lv

Attachment:

- Sign-In Sheet

I. INTRODUCTION

- A. Owner – Reading Regional Airport
 - a. Zackary Tempesco – RRA
 - b. Mike Laity – RRA
 - c. Ken Shadursky - RRA
- B. Architect – Muhlenberg Greene Architects
 - a. James A. Sarro, AIA – MGA
 - b. Grace Cai – MGA

II. BIDDING REQUIREMENTS

- 2.1 There will be Four (4) Prime contractors on this project, General, Plumbing, HVAC, and Electrical.
- 2.2 Bids are due **Thursday, August 15, 2024 at 2:00 p.m.**, at the Reading Regional Airport Administration Office, located at 2501 Bernville Road, Reading, PA 19605. Prevailing time for delivery of bids will be based according to the clock in the Administration Office. Public opening and reading will take place at this time.
- 2.2 Please review the bidding requirements and instruction to bidders carefully and ensure all required information is provided. Incomplete bid packages will be disqualified.
- 2.3 Questions and requests for clarification or interpretations of the Bid Documents shall be made in writing to the Architect no later than **Monday, August 12, 2024 by 3:00 pm**. No verbal questions from bidders will be reviewed or accepted. E-Mail to jims@mg-architects.com and/or gracec@mg-architects.com is considered a form of written RFI.
 - a. RFI's, Substitution Requests, etc. must be submitted in writing to the office of MGA regardless of the Prime Contract being bid. We will distribute them to our consultants, as required, and respond in writing to you. Any clarification or change to the Project Documents will be identified in an Addendum. If it is not identified in an Addendum, it is not an official change to the Project Documents, bidders are obligated to meet the scope of work indicated in the project documents and addenda.
 - b. Verbal responses from the Architect or its Consultants are not considered an official change to the contract requirements.
 - c. Bidders shall be required to acknowledge receipt of all issued Addenda as part of their bid package. Failure to acknowledge receipt of all Addenda MAY disqualify your bid, however, it WILL NOT absolve a bidder from meeting the project requirements set forth in each Addenda.

-
- 2.4 Two (2) original copies of the Bid Proposal Form must be submitted. Any revisions to the Bid Proposal Forms will be provided by Addendum.
- a. Two (2) copies of a Non-Collusive Affidavit must accompany the Bid Proposal Form; at least one (1) copy must be an original.
 - b. Two (2) copies of the Qualified Contractor Certification Form must accompany the bid proposal form; at least one (1) copy must be an original.
 - c. Each Bid Proposal Form must be accompanied by security in the form of a certified check, certified bank treasurer's check, bank cashier's check, or bid bond provided in the bidding documents, in the amount of ten percent (10%) of the total amount of the Bid drawn to the order of the Reading Regional Airport. Bonds must be submitted in duplicate - at least one (1) copy must be an original. Costs of bonds are to be included in the contractor's Base Bid.
 - d. All spaces provided on the Bid Form that apply to a particular contract must be filled in completely.
 - e. Do not qualify any item or portion on the Bid Form.
 - f. Voluntary alternates are not allowed and will disqualify the bid.
 - g. Any Bid submitted which does not comply with these requirements may be rejected as non-conforming.
 - h. Contractor Qualification Statements, using AIA Document A305, must also include a minimum of three references from recent projects, similar in scope to the contracted work planned for this project. The references must include direct contact information with an individual who was involved in the project cited and is familiar with your services.
- 2.6 All Contractors must abide by the Airports rules of no use of drug, alcohol or tobacco (Including chew products) within the fence line.
- 2.8 Payment and Performance Bonds are required. Costs of bonds are to be included in contractor's Base Bid.
- 2.9 Carefully review the Multiple Contract Summary and Bid Inclusion sections of the specifications for additional scopes of work, Allowances, or labor and materials that are to be included as part of the base bid. Any items not used will be credited back to the owner based on the unit prices provided. Each bidder is to provide all required unit prices listed under THEIR contract. Specific items are in addition to the scope of work identified and are only for use if needed as a result of unknown conditions. Unit

Prices apply to these provisions. This additional work is to be included as a separate line item on the schedule of values.

- 2.10 Specific scope items with Unit Prices are noted as ADDITIONAL to the scope of work identified in the bid package. Each additional scope of work or unit prices is to be included on a separate line on of the Schedule of Values, but is NOT to be included in the base bid amount.
- 2.11 Carefully review the Summary of Work and Toilet, Bath, and Laundry Accessories specification sections for items that are to be furnished by the owner and installed by the contractor.
- 2.15 Additional site visits may be scheduled for August 1st and 2nd. Contractors must schedule their visits through Zackary Tempesco or Mike L.

III. PROJECT SCHEDULE

- 3.1 Expected award of contract and issuing of the Notice to Proceed is September 2024.
- 3.2 Liquidated damages are included in the contract. The Notice to Proceed will initiate the preconstruction phase work, including the submission of Product Information and Shop Drawings thus providing ample time for delivery of products to the site. Particular attention is to be paid to long lead time items. Timely completion of the work is the responsibility of the contractors. Requests for time extension resulting from product lead times will not be approved.
- 3.3 The airport will remain operations while the project takes place. All construction activities must be restricted to the designated areas.
- 3.4 Access to the buildings will be restricted and must be coordinated with the airport.
- 3.5 A Pre-Construction Meeting will be scheduled once the contracts have been awarded, it is anticipated that this meeting will take place at the end of September. Please ensure that each prime contractor will have a representative available at that time.

IV. MISCELLANEOUS ISSUES

- 4.1 Project coordination is as described in the Project manual and is to be provided under the GC contract.
- 4.3 Compliance with OSHA Regulations and Safety Requirements will be the responsibility of each prime contractor.
- 4.4 Prime Contractors must provide insurance according to the limits outlined in the Project Manual.

- 4.5 Work sequences and storage of materials must be reviewed and approved by the Architect before commencing the work or storing materials.
- a. Contractors' use of the site is limited to the constraints shown on the drawings. The airport remains operational and the parking areas and driveways adjacent to the buildings will be used and must be kept open for use by staff and deliveries.
- 4.6 Substitution requests are to be made to the architect no later than 10 days prior to bids being due. Specifications indicate requirements for substitution requests.

V. QUESTIONS/ANSWER

An opportunity to ask questions was provided with the acknowledgement that questions must be submitted in writing to receive formal responses. Contractors were advised to refer to the Addenda for any further clarification for answers to questions raised during the Pre-Bid Conference.

The question and answer session was concluded, and the Contractors could freely review the work areas.

The above minutes are a summary in accordance with the author's understanding. Anyone requesting revisions or corrections must notify this office, in writing, within three (3) days of receipt of these minutes.

End of Minutes

SIGN-IN SHEET



Project: RRA-Multiple Building Renovations
 Pre-Bid Meeting
 Proj.#: 24-0022 Meeting Date: July 31, 2024

ATTENDANCE LIST

Name (Print Clearly)	Title	Company	Phone	Email
James A. Sarro, AIA	Principal	Muhlenberg Greene	610-376-4927	jims@mg-architects.com
Grace Cai	Architect	Muhlenberg Greene	610-376-4927	gracec@mg-architects.com
Zackary Tempesco	Airport Director	RRA	610-372-4666	ztempesco@readingairport.org
Mike Laity	Director of Operations	RRA	610-372-4666	mlaity@readingairport.org
Ken Shadursky	FBO Manager	RRA	610-372-4666	kshadursky@readingairport.org
Aaron Weiss	Superintendent	Danolt	856-9239330	MATT@danolt.com
Michael Micorzi	Broker	Broker	484 256 8082	MMicorzi@Brokerconstruction.com
Steve Wyrnek	Estimator	Balton Construction	484-336-4666	Steve@baltonconstruction.com
Eric Miller	Superintendent	Balton Construction	610-914-4093	Eric@baltonconstruction.com
Sareel Smith		Shannon A Smith Inc	717 866 6643	Office @ sasinc.us
JORDAN Juskooska	Estimator/Project manager	Hiravision Electric	484-955-7829	jordanj@hiravisionelectric.com
JOE SAADI	PM	JBM MECHANICAL	484 468 1650	JFO@JBMMECHANICAL.COM
ERIC AUBER	VP SENIOR ESTIMATOR	VISION MECH.	610-376-6805	ERCAUBER@VISIONMECHANICAL.COM
SCOTT BLANKENHORN		HEIM CONSTRUCTION	370 968 4445	SCOTT@HEIMCONSTRUCTION.COM



Name (Print Clearly)	Title	Company	Phone	Email
Dan Wirmann	PM	Dolan Const.	717-644-0375	d.wirmann@dolanconstructioninc.com
Jeff Goner	PM	Dolan Construction	717-808-9710	jeffgoner@dolanconstructioninc.com
Tyris Aptaker	Owner	Detailer Roofing	717-200-4000	t.aptaker@detailerroofing.com
Darius Di Fiore	DOC	KINSLEY	717-324-917	DDiFiore@kinsleydustroctor.com
Steve Sostak	EST	E R Shepma	610-316-1034	ssostak@erscon.com
Dan O'Neill	Sales Rep	Sherrin Williams	610-207-2100	danooneille@sherrin.com
Connor O'Brig	Estimates	O'Brig Construction	610-781-1851	coobrig@obrig.com
NOAH ZAIDTA	PM	FIVE STAR	610-719-6415	ALICIA@FIVESTARMECHANICAL.COM
STEWART TOS #410	STEWART TOS #410	STEWART TOS #410	215-452-7309	jmemmahan@10420.com
Chad Helfner	PM	Leibold Inc.	610-781-1916	chad.helfner@leiboldinc.com
Mike Vothko	Estimator	NCI Construction	484-709-2416	estimating@nciltd.com
Cameron Miller	Project Engineer	Stephen Construction	267-885-9551	estimating@stephenconstruction.com
Tom Jones	Roofers Local 30	Roofers Local 30	215-964-2422	Tom Jones@RoofersLocal30.com
Nowhlyre	AACT Estimator	HPLI	570-495-3586	nowhlyre@construction.net

Muhlenberg Greene Architects, Ltd. / 955 Berkshire Boulevard, Suite 101 / Wyomissing, PA 19610-1278
 Phone: 610-376-4927 / Fax: 610-376-0720 / E-mail: LaurenV@MG-Architects.com / www.MG-Architects.com



Name (Print Clearly)	Title	Company	Phone	Email
Sarah Phillips Chris Ebright	dsL Hammett	Insh Creek Insh Creek	410 587 8306 484 697 8258	sarah@inshcreekinc.com c.ebright@inshcreekinc.com
Ralph Reinhart	est / PM est	Empire H.B. Frazer	484 709 5070 610-603-0616	shaww@fresreading.com ghenno@hbfraser.com
TODD CAMERON Grace Cai BOB GARWARD		PURCELL MG Architects. WPAVED	717 336 7400 610 587-3505	tjcameron@purcell.com grace@MG-Architects.com bobg@thewavedgroup.com

Muhlenberg Greene Architects, Ltd. / 955 Berkshire Boulevard, Suite 101 / Wyomissing, PA 19610-1278
 Phone: 610-376-4927 / Fax: 610-376-0720 / E-mail LaurenV@MG-Architects.com / www.MG-Architects.com

Jim A. Sarro, AIA, LEED AP+

From: Jim A. Sarro, AIA, LEED AP+
Sent: Wednesday, July 31, 2024 9:22 AM
To: Steve Warnek
Subject: RE: Reading Airport

See responses below in RED.



James Sarro, AIA, LEED AP BD+C

Phone : 610.376.4927

Mobile : 610.310.6150

Email : JimS@MG-Architects.com

From: Steve Warnek <Steve@baltonconstruction.com>
Sent: Monday, July 29, 2024 12:32 PM
To: Jim A. Sarro, AIA, LEED AP+ <JimS@MG-Architects.com>
Subject: Reading Airport

Hi Jim,

From our insurance agent-

1. Section 11.1.1.1 – 2: Independent Contractor’s Protective. Is this referring to Owners and Contractors Protective Liability (OCP)? If not, what exactly is this provision referring to? **Yes, this is referring to the owners and Contractors Protective Liability.**
2. Can the Contractor make up for insufficient General Liability insurance limits with increased Umbrella Liability limits? (I.e., if the GL limits are \$1 million per occurrence, \$2 million aggregate, and the umbrella limit is \$5 million, is this sufficient?) **yes, this is acceptable.**
3. Will the contractor be listed on the owner’s builder’s risk policy as an Additional Named Insured? **If the owner choses to provide Builders Risk insurance than yes.**

Thank you,

Steve Warnek
Project Manager/Estimator



Balton Construction, Inc
25 East Main Street
PO Box 600
Richland, PA 17087

Phone: 484-336-4666
Fax: 888-753-6419

Email: steve@baltonconstruction.com

Website: <https://baltonconstruction.com/>

Jim A. Sarro, AIA, LEED AP+

From: Jim A. Sarro, AIA, LEED AP+
Sent: Wednesday, July 31, 2024 9:35 AM
To: 'Steve Warnek'
Subject: RE: Reading Airport

See responses below in **RED**.



James Sarro, AIA, LEED AP BD+C

Phone : 610.376.4927

Mobile : 610.310.6150

Email : JimS@MG-Architects.com

From: Steve Warnek <Steve@baltonconstruction.com>
Sent: Monday, July 29, 2024 3:50 PM
To: Jim A. Sarro, AIA, LEED AP+ <JimS@MG-Architects.com>
Subject: RE: Reading Airport

Hi Jim,
More from the insurance agent-

Under Section 11.1.1.1 – 4: What exclusion is this referring to? Can you please provide a sample or more details about what coverage you are looking for? Is it EPLI? **Yes, these appear to be the same thing.**
Under Section 11.1.1.1 – 7: What is meant by Broad Form Property Damage? Is this property in our Care Custody or Control? Or something else? Standard GL policies exclude coverage for property in your care custody or control, but there is also reference of a builder's risk policy being purchased by the owner. Per our earlier question, is the Contractor going to be included as an additional named insured? **The owner may purchase builders risk insurance, if they so choose. This is the liability exposure represented by the risk of property loss in the contractors care, custody, or control (CCC). For example, a painter is burning paint off a home and sets the home on fire, the damage to the property is covered.**

Thank you,
Steve Warnek
Project Manager/Estimator
484-336-4666

From: Steve Warnek
Sent: Monday, July 29, 2024 12:32 PM
To: 'Jim A. Sarro, AIA, LEED AP+' <JimS@MG-Architects.com>
Subject: Reading Airport

Hi Jim,
From our insurance agent-

1. Section 11.1.1.1 – 2: Independent Contractor's Protective. Is this referring to Owners and Contractors Protective Liability (OCP)? If not, what exactly is this provision referring to?

2. Can the Contractor make up for insufficient General Liability insurance limits with increased Umbrella Liability limits? (I.e., if the GL limits are \$1 million per occurrence, \$2 million aggregate, and the umbrella limit is \$5 million, is this sufficient?)
3. Will the contractor be listed on the owner's builder's risk policy as an Additional Named Insured?

Thank you,

Steve Warnek
Project Manager/Estimator



Balton Construction, Inc
25 East Main Street
PO Box 600
Richland, PA 17087

Phone: 484-336-4666
Fax: 888-753-6419

Email: steve@baltonconstruction.com
Website: <https://baltonconstruction.com/>

Jim A. Sarro, AIA, LEED AP+

From: Jim A. Sarro, AIA, LEED AP+
Sent: Tuesday, July 30, 2024 3:32 PM
To: Steve Warnek
Subject: RE: Reading Airport

Yes, this will need to be submitted with the bid.

Thanks



James Sarro, AIA, LEED AP BD+C

Phone : 610.376.4927

Mobile : 610.310.6150

Email : JimS@MG-Architects.com

From: Steve Warnek <Steve@baltonconstruction.com>
Sent: Tuesday, July 30, 2024 9:01 AM
To: Jim A. Sarro, AIA, LEED AP+ <JimS@MG-Architects.com>
Subject: Reading Airport

Hi Jim,
Does this need to be submitted with the bid?

Thank you,

Steve Warnek
Project Manager/Estimator



Balton Construction, Inc
25 East Main Street
PO Box 600
Richland, PA 17087

Phone: 484-336-4666
Fax: 888-753-6419

Email: steve@baltonconstruction.com
Website: <https://baltonconstruction.com/>

Jim A. Sarro, AIA, LEED AP+

From: Jim A. Sarro, AIA, LEED AP+
Sent: Thursday, August 1, 2024 12:34 PM
To: Lori Rebuck
Cc: Noah Wise; Grace Cai, AIA
Subject: RE: RFI: Reading Regional Airport Project

See response below in RED.



James Sarro, AIA, LEED AP BD+C

Phone : 610.376.4927

Mobile : 610.310.6150

Email : JimS@MG-Architects.com

From: Lori Rebuck <lrebuck@hpconstruction.net>
Sent: Thursday, August 1, 2024 10:58 AM
To: Jim A. Sarro, AIA, LEED AP+ <JimS@MG-Architects.com>
Cc: Noah Wise <nwise@hpconstruction.net>
Subject: RFI: Reading Regional Airport Project

Good morning,

Dwg A110 - Note: 9.92.12 Underside of the roof structure to be painted. Is this correct? Please clarify.
The entire interior surface of the roof is to be painted, including the deck and supporting structure.

If you have any questions, please do not hesitate to contact us.

Respectfully submitted,

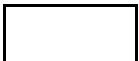

Lori A. Rebuck
H&P Construction, Inc

PH: (570) 373-1605 Direct: 570-205-4606

lrebuck@hpconstruction.net

[10788 State Route 61, Kulpmont, PA 17834](#)

Jim A. Sarro, AIA, LEED AP+

From: Jim A. Sarro, AIA, LEED AP+
Sent: Thursday, August 1, 2024 3:01 PM
To: Todd Cameron
Subject: RE: Reading Airport project

The bid date will be extended to Monday, August 19th. The board will be meeting on Tuesday, August 20th to review the bids.



James Sarro, AIA, LEED AP BD+C

Phone : 610.376.4927

Mobile : 610.310.6150

Email : JimS@MG-Architects.com

From: Todd Cameron <tjcameron@purcellgc.com>
Sent: Thursday, August 1, 2024 12:36 PM
To: Jim A. Sarro, AIA, LEED AP+ <JimS@MG-Architects.com>
Subject: Reading Airport project

Jim,
Due to conflicts would it be possible to extend this project bid date into the following week? Please advise. Thank you.

Todd J Cameron
Vice President of Operations

PURCELL CONSTRUCTION
A Woman Business Enterprise
717.336.7400 x119
717.336.0877 Fax

Jim A. Sarro, AIA, LEED AP+

From: Jim A. Sarro, AIA, LEED AP+
Sent: Thursday, August 1, 2024 12:45 PM
To: 'Connor Uhrig'; ztempesco@readingairport.org; s.gribb@sdei.net
Cc: Grace Cai, AIA
Subject: RE: Reading Regional Airport - RFI Window Treatments



James Sarro, AIA, LEED AP BD+C

Phone : 610.376.4927

Mobile : 610.310.6150

Email : JimS@MG-Architects.com

From: Connor Uhrig <CUhrig@uhrig.com>
Sent: Thursday, August 1, 2024 10:14 AM
To: ztempesco@readingairport.org; Jim A. Sarro, AIA, LEED AP+ <jims@MG-architects.com>; s.gribb@sdei.net
Subject: Reading Regional Airport - RFI Window Treatments

Good Morning,

Please address the following RFI's regarding window treatments.

1. Specification 122413 2.3E requires a cord lift/lock on the blinds.
This systems is no longer available due to a ruling of the CPSC which eliminates exposed cords.
All horizontal blinds now have cordless operation only. **Understood, please provide cordless operation per the CPSC ruling.**
This system has size limitations (see my next question) which may preclude fabrication altogether.
Perhaps a roller shade would be a better option. **Please submit a substitution request and we will evaluate.**
2. Are there any elevations from which to get the window height for the windows requiring blinds? **Utilize a 6' window height for bidding purposes, actual window sizes will need to be field verified.**
3. Can you please confirm that Room 104 Waiting area does not get new blinds. **Correct.**

Thanks
Connor

Connor Uhrig

Project Manager/Estimator

UHRIG CONSTRUCTION, INC.

1700 N 5th Street

Reading PA 19601

cuhrig@uhrig.com

610-373-1612 P

Jim A. Sarro, AIA, LEED AP+

From: Jim A. Sarro, AIA, LEED AP+
Sent: Thursday, August 1, 2024 3:11 PM
To: Connor Uhrig; ztempesco@readingairport.org; s.gribb@sdei.net
Cc: Grace Cai, AIA
Subject: RE: Reading Regional Airport - RFI Window Treatments

Finishes for NEW toilet rooms 105, 106, and 107 are located on Sheet A-103, Enlarged Toilet Room Plans.



James Sarro, AIA, LEED AP BD+C

Phone : 610.376.4927

Mobile : 610.310.6150

Email : JimS@MG-Architects.com

From: Connor Uhrig <CUhrig@uhrig.com>
Sent: Thursday, August 1, 2024 2:45 PM
To: Jim A. Sarro, AIA, LEED AP+ <jims@MG-architects.com>; ztempesco@readingairport.org; s.gribb@sdei.net
Cc: Grace Cai, AIA <GraceC@MG-Architects.com>
Subject: RE: Reading Regional Airport - RFI Window Treatments

Hello,

Please advise on the following RFI.

- Toilet rooms 105, 106 & Pilot toilet 107 call to be demo'd but there are no finishes for them.
 - o Are these areas being demo'd? If yes what are the finishes?

Thanks
Connor

Connor Uhrig

Project Manager/Estimator

[UHRIG CONSTRUCTION, INC.](#)

1700 N 5th Street

Reading PA 19601

cuhrig@uhrig.com

610-373-1612 P

610-781-1851 C

610-372-3193 F

From: Jim A. Sarro, AIA, LEED AP+ [<mailto:jims@MG-architects.com>]
Sent: Thursday, August 1, 2024 12:45 PM
To: Connor Uhrig <CUhrig@uhrig.com>; ztempesco@readingairport.org; s.gribb@sdei.net
Cc: Grace Cai, AIA <GraceC@MG-Architects.com>
Subject: RE: Reading Regional Airport - RFI Window Treatments

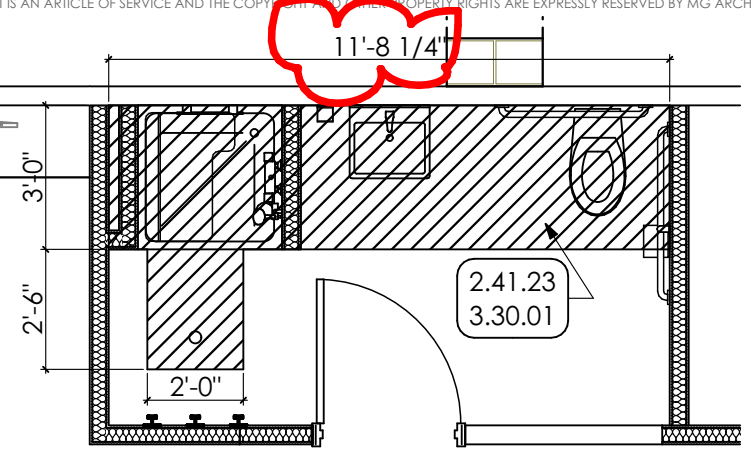
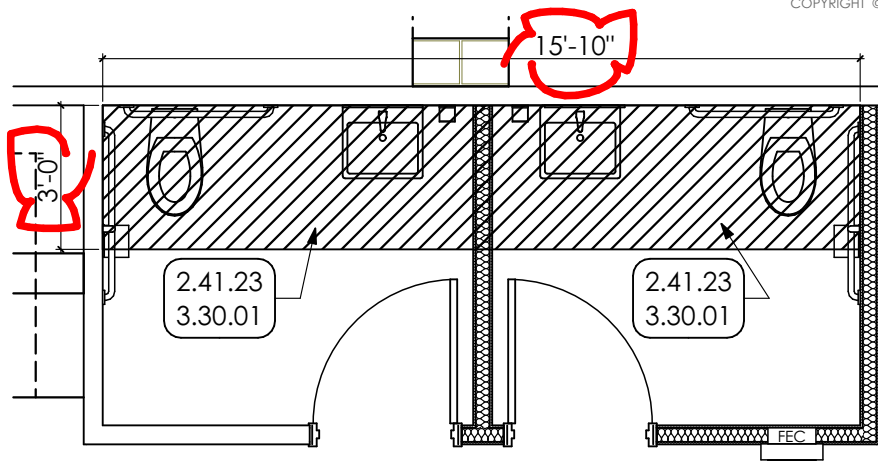

1 SLAB REPAIR PLAN

SCALE: 1/4" = 1'-0"

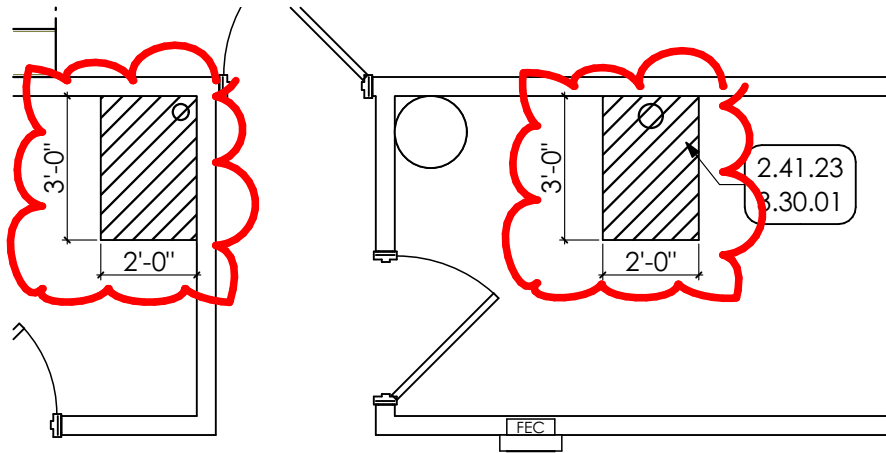

2 SLAB REPAIR PLAN

SCALE: 1/4" = 1'-0"

READING REGIONAL AIRPORT

MULTIPLE BUILDING RENOVATIONS

2501 Bernville Road Reading, PA 19605

PROJ. MGR.: Grace Cai AIA	P.M. e-MAIL: GraceC@MG-Architects.com
DRAWN BY: RMM	DATE: 08/01/2024
CLIENT PROJ #: -	CLIENT: ZACKARY TEMPESCO

SLAB REPAIR PLAN

PROJECT #:
24-0022

SD-001

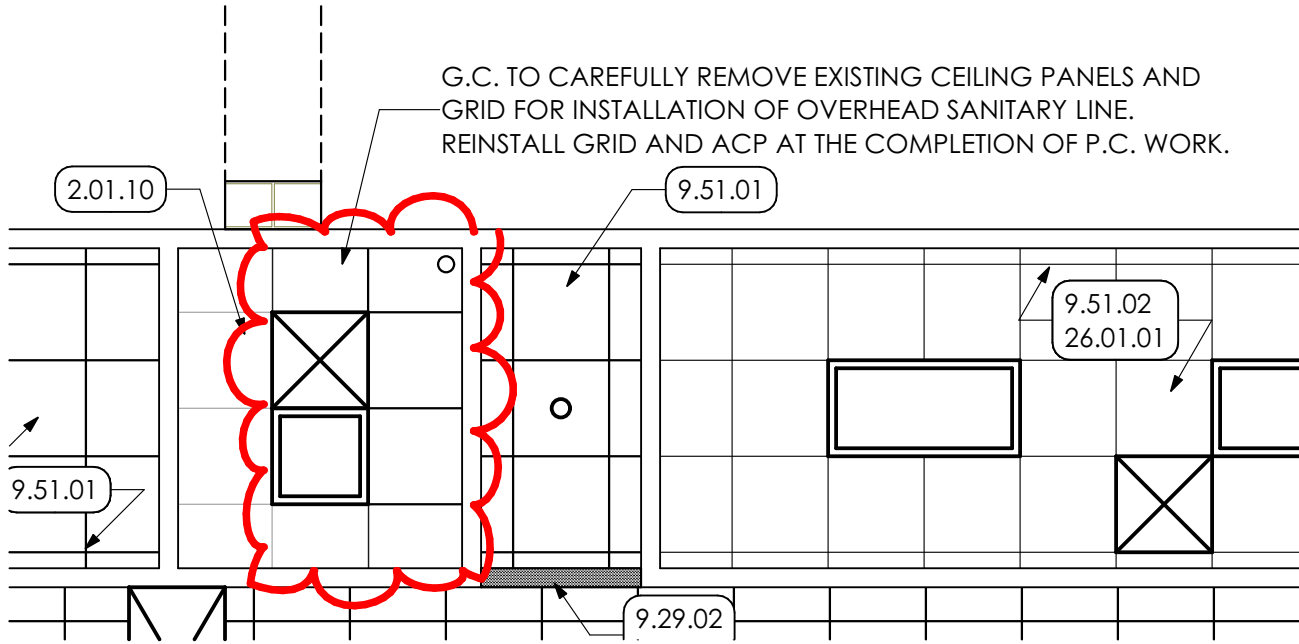

REFLECTED CEILING PLAN

SCALE: 1/4" = 1'-0"

24-0022.0_Reading Airport Renovations-Hanger 1.pln | P:\24-0022.0_Reading Airport Renovations\1-Design\24-0022.0_Reading Airport Renovations-Hanger 1.pln | 8/1/2024 | 1:35 PM

READING REGIONAL AIRPORT

MULTIPLE BUILDING RENOVATIONS

2501 Bernville Road Reading, PA19605

PROJ. MGR.: Grace Cai AIA	P.M. e-MAIL: GraceC@MG-Architects.com
DRAWN BY: RMM	DATE: 08/01/2024
CLIENT PROJ #: -	CLIENT: ZACKARY TEMPESCO

REFLECTED CEILING PLAN

PROJECT #:
24-0022

SD-002