



# C01-2

**4KW COMBINER  
1.8 - 54 MHz**

**USER MANUAL**



Rev. 1.0

## Index

IMPORTANT .....	3
HOW TO READ THIS MANUAL .....	3
PRECAUTIONS.....	4
UNPACKING .....	6
1. PANEL DESCRIPTION .....	7
1.1 Front Panel.....	7
1.2 Rear Panel.....	8
2. GENERAL INFORMATION .....	9
2.1 Power supply.....	9
2.2 External Ground Connection (Gnd).....	9
2.3 Kit Cables (option).....	9
2.4 "PORT IN" Connector.....	10
2.5 "PORT OUT" Connector.....	11
2.6 "REMOTE" Connector.....	12
2.7 Alarms.....	13
3. USE OF THE COMBINER .....	14
3.1 Block Diagram.....	14
3.2 Interconnection with NON Expert Amplifiers.....	15
3.3 Interconnection WITH Expert Amplifiers.....	16
3.4 PORT Cable.....	18
3.5 CAT Cable.....	19
3.6 CAT, ALC, PTT cables without PC.....	21
PTT, ALC, CAT RS 232 cables.....	22
PTT, ALC, CAT TTL Yaesu cables.....	22
PTT, ALC, CAT TTL Kenwood cables.....	23
PTT, ALC, CAT BAND DATA cables.....	23
3.7 CAT, ALC, PTT cables with PC.....	24
PTT, ALC, CAT Icom CI-V cables.....	24
PTT, ALC, CAT RS 232 cables.....	25
PTT, ALC, CAT TTL Kenwood cables.....	26
4. INITIAL OPERATION .....	27
4.1 Synchronization of the Amplifiers.....	27
4.2 Set-up of the ATU.....	28
5. MAINTENANCE .....	29
6. REMOTE CONTROL OF THE AMPLIFIERS.....	30
6.1 Computer Connection.....	31
6.2 Selective Addressing.....	31
7. WARRANTY TERM.....	33

We congratulate you on the choice of the Combiner CO1-2.

With this device you can add the power of two linear amplifiers, even those not produced by SPE.

It is recommended that amplifiers not produced by SPE are as equal to each other as possible to avoid that the strong difference in power between the two is dissipated by the balancing resistance contained in the Combiner itself.

In regards to SPE production amplifiers, thanks to the unique use of ALC, the difference in output of the two amplifiers is automatically reduced to the minimum (the highest output is reduced to approximately the same output as the less powerful amplifier) in order to make the dissipation of the balancing resistance insignificant.

In addition, all Expert amplifiers retain their characteristics such as CAT control, use of the internal ATU, and the ability to select up to six antennas (see chapter 3.3).

The Combiner CO1-2 optimizes the investment of the station as it allows the increase of the power in successive steps whilst still maintaining the two separate amplifiers available for DXpeditions or field days.

The device is not managed by software, so no upgrading will ever be necessary.

## IMPORTANT

Before installing and using the equipment, we recommend that you read the instructions in this manual carefully.

Failure to follow these instructions will result in voiding the warranty.

Keep the manual, it contains important information regarding the safety and correct use of the Combiner.

## HOW TO READ THIS MANUAL

The manual can conceptually be divided into three parts:

- **First part, from chap. 1 to chap.3.**  
Shows the main features of the CO1-2 and how to connect it.
- **Second part, from chap. 4 to chap. 5.**  
Describes how to operate and maintain the CO1-2.
- **Third part, chap. 6.**  
Describes the use of the software provided for remote control of the two Expert amplifiers used.

## PRECAUTIONS

### *Explicit definitions*

WORD	DEFINITION
 <b>WARNING!</b>	Risk or danger of fire or electric shock to people. Possible damage to the amplifier.
<b>NOTE:</b>	Serious problems if not observed. Danger of fire or electric shock for the operator, or damage to the equipment.

### **WARNING!**

**DO NOT** disconnect the coaxial cables when the device is in transmission mode. This could cause a risk of electric shock or burns.

### **WARNING!**

**DO NOT** modify the internal settings of the device. This could reduce the performance of the Combiner or damage it.

### **WARNING!**

**Before** powering up the device, check the value of the power supply which must be compatible with the device.

### **WARNING!**

**DO NOT** use the device, before you have connected it to the protective earth.

### **WARNING!**

**DO NOT** allow metal objects or wires to penetrate inside the appliance.

### **WARNING!**

**DO NOT** obstruct the front and rear air intakes of the unit.  
**ENSURE** that no objects impede the correct functioning of the fans.

### **WARNING!**

**DO NOT** expose the equipment to rain, snow or any liquid.

### **WARNING!**

**AVOID** locations without adequate ventilation. Proper dissipation would be impeded resulting in damage to the device.

### **WARNING!**

**DO NOT** touch the device with wet or damp hands. This could cause electrocution.  
**DO NOT** open the combiner without first disconnecting it from the devices connected to it.

To clean the Combiner DO NOT use chemical agents like alcohol or benzene, as the plastic surfaces could be damaged.

AVOID using the Combiner in areas with temperatures below 0° C (+32°F) or above +40°C (+104°F).

AVOID using the Combiner in locations that are very dusty, damp, have high humidity or that are in direct sunlight.

AVOID placing the Combiner against walls where the circulation of the air would be obstructed and the noise of the fans would be reflected toward the operator.

AVOID permitting children to play with the Combiner.

### **Information for Users on Collection and Disposal of Old Equipment and Used Batteries.**



These symbols on the products, packaging, and/or accompanying documents mean that used electrical and electronic products and batteries should not be mixed with general household waste.

For proper treatment, recovery and recycling of old products and used batteries, please take them to the relevant collection points, in accordance with your national and local legislation.

**The use of the Combiner CO1-2 is allowed by operators with an adequate license. Its installation and its use (power, band, transmission mode, etc.) must comply with the current laws of the State in which it operates.**

**The Combiner is essentially passive and therefore does not require FCC certification for radio amateur use (if required).**

**However, where such certification is required, it is essential that the linear amplifiers used are FCC certified.**

## UNPACKING

Remove the packaging and carefully check the contents.

If you find any damage, or if there are any parts missing, contact your distributor/dealer immediately. It is recommended to keep the shipping cartons and packing materials for future transportation.

### Accessories included in the carton

- a. Spare air filter.
- b. 1 x Power Supply connector.
- c. 1 x DB-9M connector.
- d. 1 x DB-15M connector.
- e. Kit: PORT Cable, CAT Cable, 2 x COMBINER Cables, 2 x SPLITTER Cables. (option, see page 9)
- f. CD-ROM containing the user manual and the software for remote use.
- g. Warranty card.
- h. 1A Fuse.

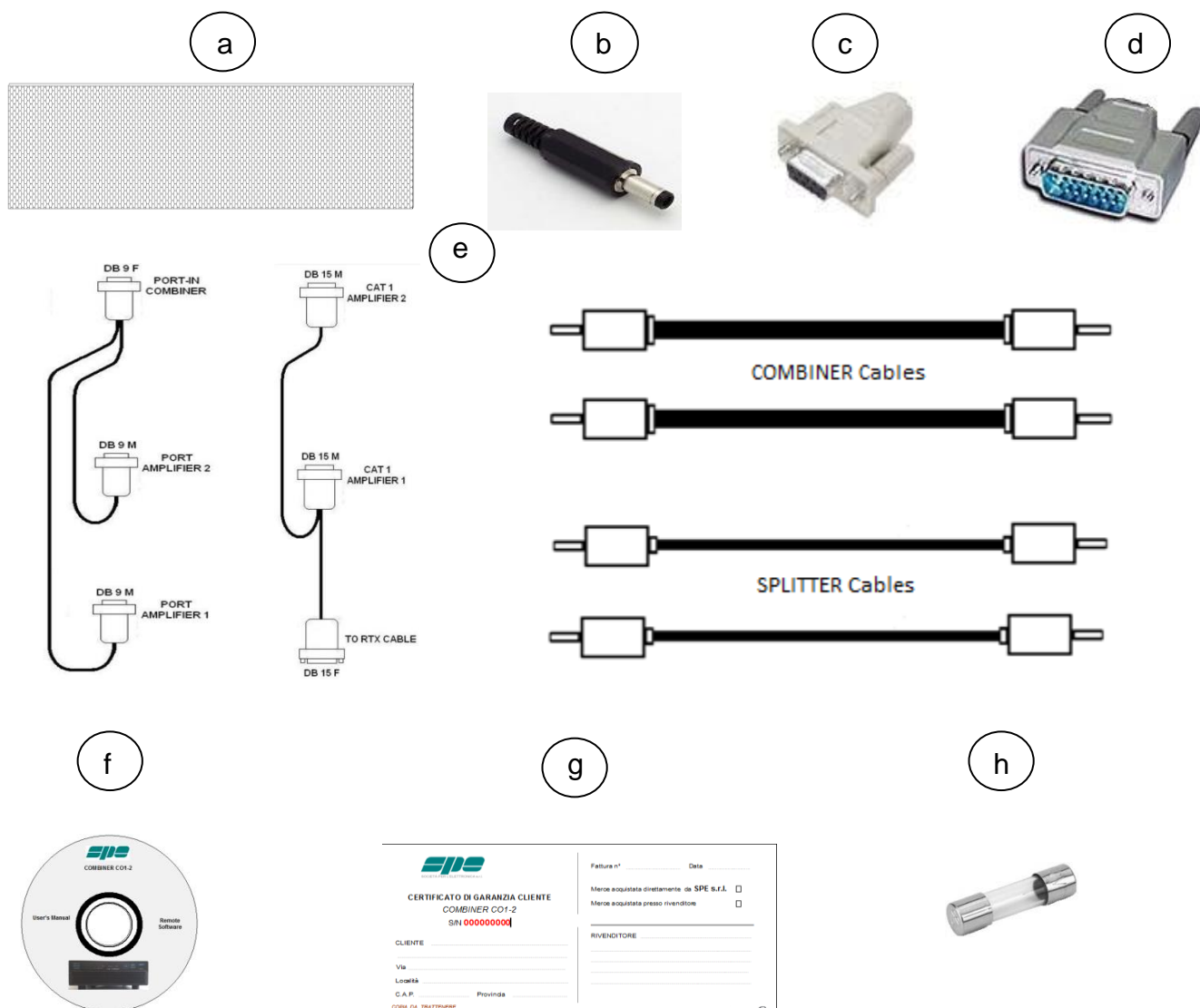

## 1. PANEL DESCRIPTION

### 1.1 Front Panel.



- 1) Led bar showing the output power.
- 2) Led bar of the power dissipated in the balancing resistor.
- 3) Alarm when 700 W imbalance is reached.
- 4) Led bar of the balancing resistance temperature.
- 5) Balancing resistance temperature alarm.
- 6) Hardware alarm or alarm of non-synchronism between the amplifiers.
- 7) Indicates that the Combiner is ON.
- 8) ON button.
- 9) Turns off the Combiner or Resets an Alarm.

## 1.2 Rear Panel.

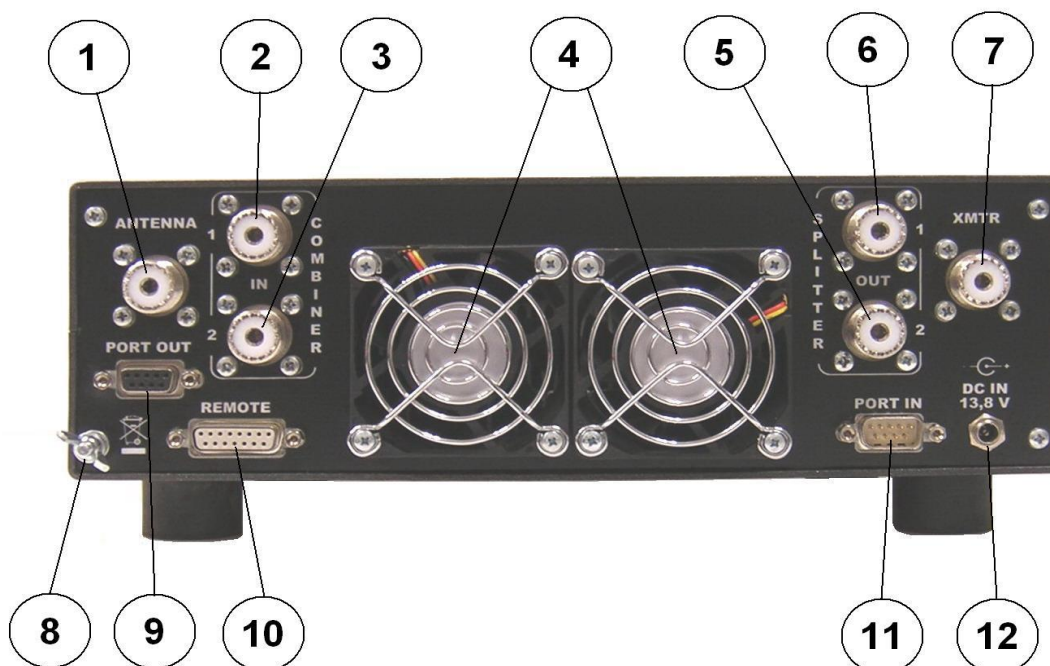

- 1) To be connected to the transmitting antenna or to the antenna switch (if in use).
- 2) To be connected to an amplifier output (COMBINER Cable).
- 3) To be connected to the output of the other amplifier (COMBINER Cable).
- 4) Fans.
- 5) To be connected to the input of an amplifier (SPLITTER Cable).
- 6) To be connected to the input of the other amplifier input (SPLITTER Cable).
- 7) To be connected to the antenna connector of the transceiver.
- 8) GND.
- 9) PORT OUT to control the Antenna Switch (if in use).
- 10) REMOTE for remote control (if in use).
- 11) PORT IN to be connected with the respective "PORT" of the two Expert amplifiers for synchronization (PORT CABLE).
- 12) Device power supply (13.8V DC, 1A.).



## 2. GENERAL INFORMATION

### 2.1 Power supply.

The Combiner is powered by an external source of 13.8 V DC nominal (15.5 V DC max).

Considering the low current required (1 A max.), the transceiver power supply can be used.

This voltage is shown on the "PORT OUT" connector in order to supply the antenna switch (optional).

There is a slow 1 A fuse inside the Combiner.

### 2.2 External Ground Connection (Gnd).

 **WARNING!** Before connecting an external ground as described below, check with a qualified electrician that your national wiring codes a connection.

To reduce TVI, BCI and other RF problems it is best to connect the amplifier to a good RF ground. (Note that an RF ground is different to an electrical ground which is necessary for the prevention of electrical shock).

The inductance of such a connection needs to be low, so the connection to ground should be as short and direct as possible.

Large-section copper conductors should be used for this purpose.

It is recommended to terminate the earth connection with a small metal plate.

The best solution is to have several ground stakes, driven into the ground, and these ground stakes also need to be tied to your main grounds.

Good results can often be achieved by using correct earthing clamps, connected to the main water supply pipe (note, many water pipes are now made out of plastic).

DO NOT use central heating pipe work.

AVOID the electric circuit ground of the building (to be used for 50/60 Hz safety only).

 **WARNING! DO NOT connect to gas pipes as there will be a danger of explosion!!**

### 2.3 Kit Cables (option).

A cable kit can be provided to connect between the two amplifiers and the Combiner; each cable is long enough to place the three devices stacked or side by side. For other provisions involving longer lengths refer to the chapters below.

The Kit consists of n. 6 cables (see page 6):

n.1 PORT Cable, n.1 CAT Cable, n. 2 x COMBINER Cable, n. 2 x SPLITTER Cable.

The CAT Cable, for construction reasons, is supplied in two versions to choose from when ordering:

CAT Cable / CAT for connection to all CATs.

CAT Cable / Band Data for the "BAND DATA" connection.

## 2.4 “PORT IN” Connector.

If you use two EXPERT amplifiers from this connector, use a Y-cable to interconnect the "PORT" connector of each amplifier.

This allows the synchronization of the two amplifiers; if not, an alarm will occur. The two amplifiers are synchronized when their settings are perfectly identical, therefore this cable is necessary in order for the Combiner to function properly.

This connector is not used with non-Expert amplifiers.

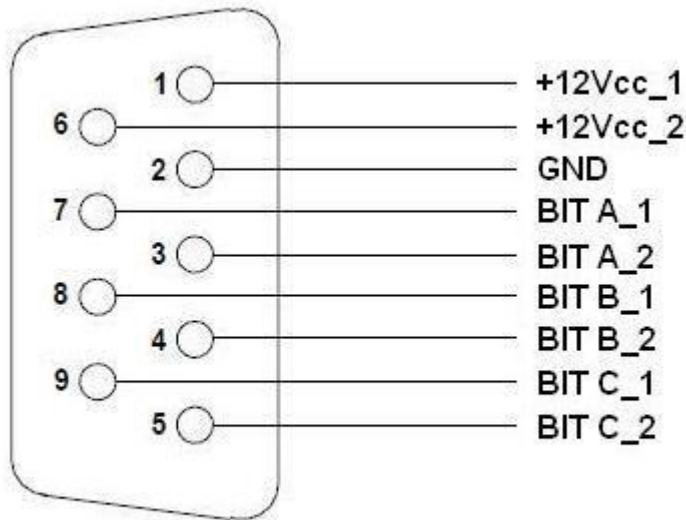

**DB 9 M**

Pin Number	Pin Name	Description
1	+ 12 V DC_1	Present when amplifier 1 is ON (input).
6	+ 12 V DC_2	Present when amplifier 2 is ON (input).
2	GND	GND.
7	BIT A_1	BIT A of the antenna set in amplifier 1.
3	BIT A_2	BIT A of the antenna set in amplifier 2.
8	BIT B_1	BIT B of the antenna set in amplifier 1.
4	BIT B_2	BIT B of the antenna set in amplifier 2.
9	BIT C_1	BIT C of the antenna set in amplifier 1.
5	BIT C_2	BIT C of the antenna set in amplifier 2.

## 2.5 “PORT OUT” Connector.

If two Expert amplifiers are used, this connector provides information in BCD open collector of the antenna set on the two synchronized amplifiers, a 13.8 V DC source is also available to power the Antenna Switch (if present).

This connector is not used with non-Expert amplifiers, if you have an external manual switch, or a single antenna.

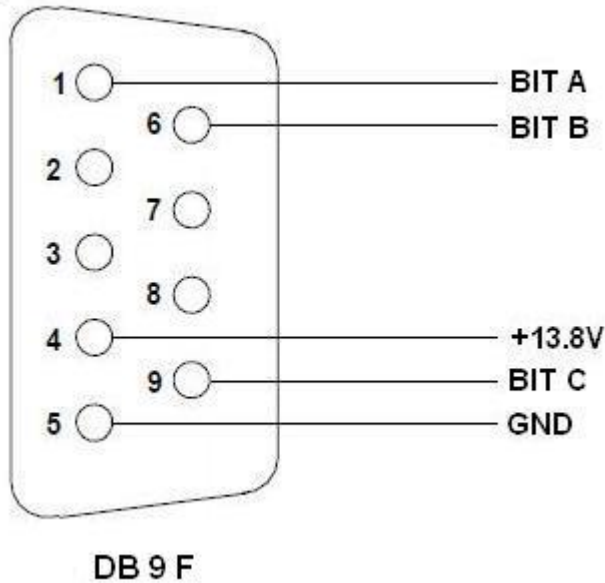

Pin Number	Pin Name	Description
1	BIT A	BIT A relates to the number of the antenna in use (open collector).
6	BIT B	BIT B relates to the number of the antenna in use (open collector).
9	BIT C	BIT C relates to the number of the antenna in use (open collector).
5	GND	GND.
2	NC	
3	NC	
7	NC	
8	NC	
4	+ 13.8 V DC	+ 13.8 V DC, to power the Antenna Switch, 0.25 A Max.

## 2.6 “REMOTE” Connector.

This connector allows remote control of the Combiner by making the terminals for the "ON", "OFF / RESET" keys and all the alarms on metal contact and open collector (40 V 100 mA max.) available to the user.

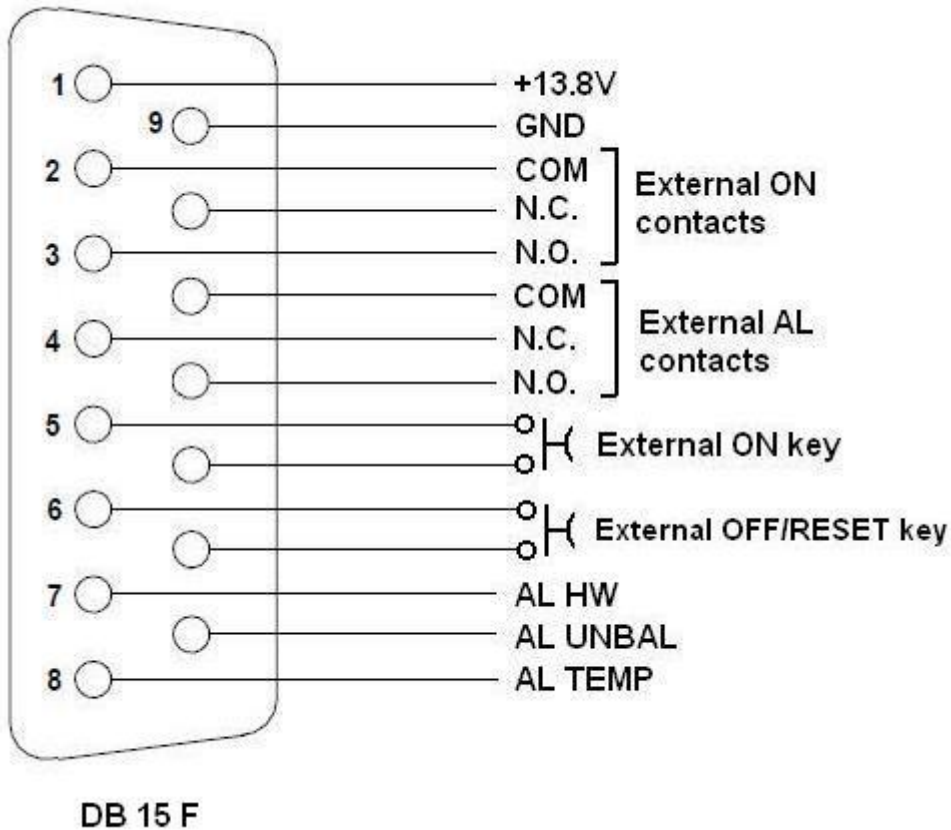

Pin Number	Pin Name	Description
1	+13.8 V DC	To supply power to an external device, 0.2 A max.
9	GND	GND.
2	COM	Relay contacts to indicate the ON status.
10	N.C.	
3	N.O.	
11	COM	Relay contacts to indicate the Alarm status (generic).
4	N.C.	
12	N.O.	
5	ON	Button or external contact for ON function
13	ON	
6	OFF / RESET	Button or external contact for OFF / RESET function
14	OFF / RESET	
7	AL HW	Synchronization alarm (open collector)
15	AL UNBAL	Unbalance alarm between amplifiers (open collector).
8	AL TEMP	Temperature alarm (open collector).

## 2.7 Alarms.

All alarms are highlighted with optical and acoustic indication and repeated in the "REMOTE" connector.

When an alarm occurs, the Combiner stops working immediately, and the transceiver is connected to an internal 250W dummy load as a precaution.

After alleviating the problem, press the "OFF / RESET" key to restore operation.

### 3. USE OF THE COMBINER

#### 3.1 Block Diagram.

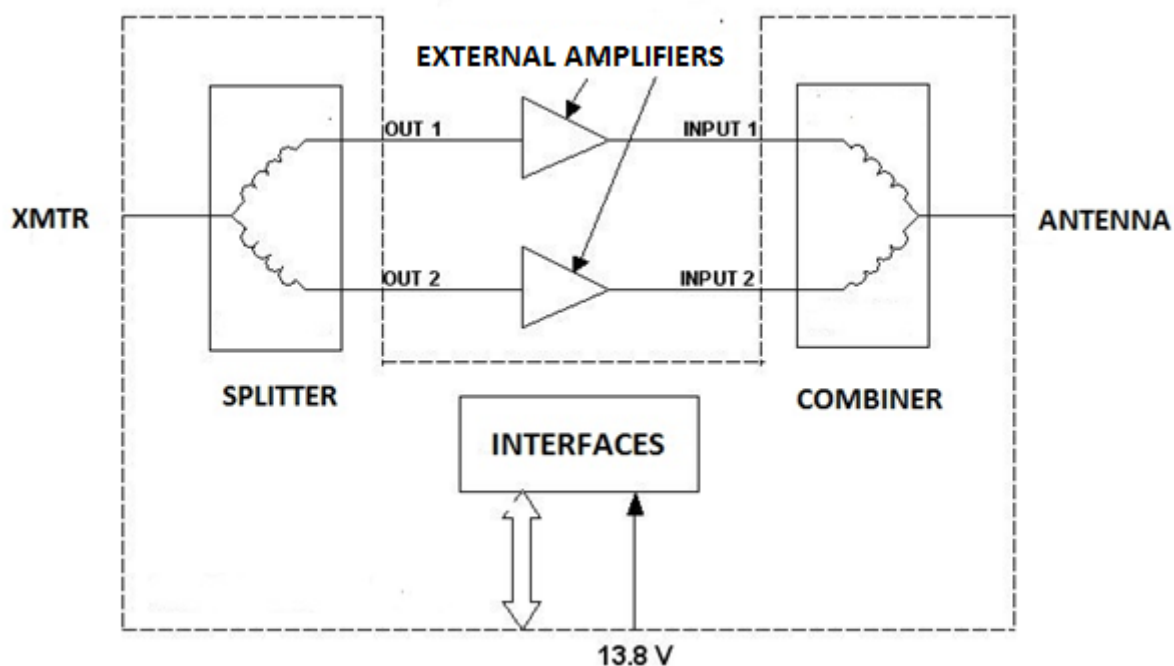

Because of the simplified structure there is no RF switching, and therefore it is not necessary to connect to the PTT of the transceiver.

The essential part of the Combiner contains exclusively passive elements; active components are only used in the interfaces (see previous chapter).

### 3.2 Interconnection with NON Expert Amplifiers.

With reference to the previous diagram:

1. Connect the transceiver output to the XMTR connector.
2. Connect the ANTENNA connector to the antenna in use.
3. Connect the amplifier inputs with the SPLITTER out 1 and out 2 connectors.

**WARNING:** it is absolutely necessary that the two cables are of exactly equal lengths and are of the same make and model.

4. Connect the amplifier outputs to the COMBINER connectors 1 and 2.

**WARNING:** it is absolutely necessary that the two cables are of exactly equal lengths and are of the same make and model.

Use cables that are suitable for adequately handling the power involved.

The GND and 13.8 V DC connections must also be made.

The "PORT IN" and "PORT OUT" connectors must not be used.

**ATTENTION:** When using non-Expert amplifiers, it is recommended that the two amplifiers are set so that they generate the most equal power out.

This can be achieved by minimizing the indication of the LED bar of the power dissipated in the balancing resistor (800 W max.).

It would be a good idea to separately tune each amplifier to the antenna, and then connect it to the Combiner.

### 3.3 Interconnection WITH Expert Amplifiers.

To simplify the understanding, refer to the example photo and drawing of the complete connections between two 1.5K-FA Experts / Combiner / Transceiver / Remote Switch and PC.

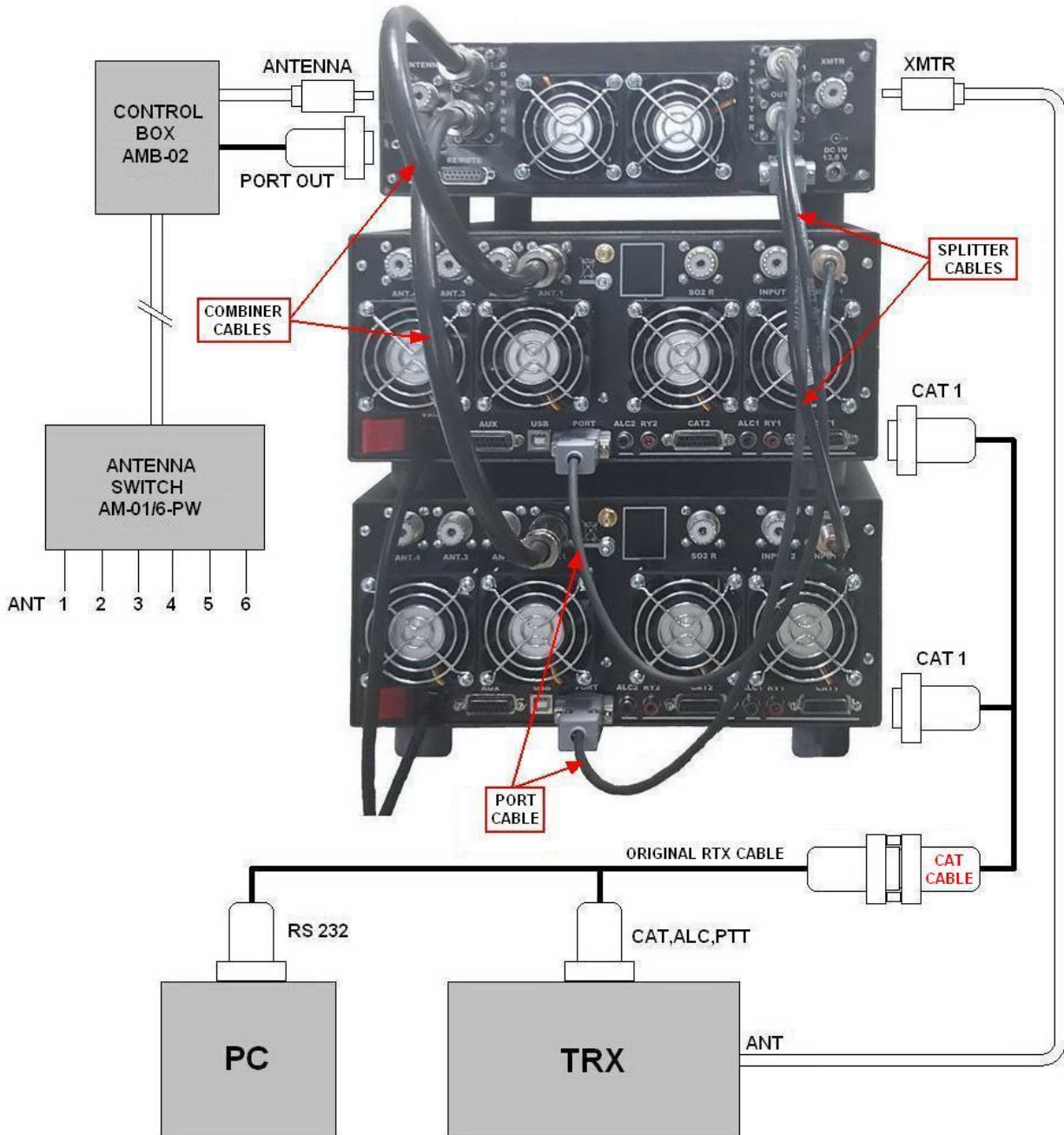



1. Connect the transceiver output to the XMTR connector.
2. Connect the ANTENNA connector to the antenna in use or the Antenna Switch.
3. Connect the amplifier inputs with the SPLITTER out 1 and out 2 connectors using the two "SPLITTER cables".  
**WARNING:** If the distances of use are greater, it is absolutely necessary that the two new cables are of exactly equal lengths and are of the same make and model.
4. Connect the outputs of the amplifiers with the COMBINER connectors in 1 and in 2 using the two "COMBINER cables".  
**WARNING:** If the distances of use are greater, it is absolutely necessary that the two new cables are of exactly equal lengths and are of the same make and model.  
Use cables that are suitable for adequately handling the power involved.
5. Connect the "PORT IN" of the Combiner with the "PORT Cable" to each "PORT" of the two Experts (if the distances of use are greater, see chapter 3.4).
6. Connect the "CAT1" connectors of each Expert with the CAT, ALC and PTT outputs of the transceiver with the "CAT Cable" (if the distances of use are greater, see chapter 3.5).

The old CAT cable which originally interfaced only to one amplifier can be connected directly to the extension of the supplied Y cable (connector DB-15F). If there are also cables with RCA connectors, just keep their existing connection with one of the two amplifiers.

This solution makes installation very easy and quick.

In the absence of a previous installation (old CAT cable missing), it is necessary to build a new cable, the following two options are possible:

- a) For connection with the transceiver only (see chapter 3.6).
- b) For connection with the transceiver and a PC (see chapter 3.7).

The GND and 13.8 V DC connections must also be made.

The connection to the "PORT OUT" is to be used only in presence of the remote antenna switch "AMB-01-PW" with the ability to remotely select the 6 antennas set in the Expert.

Refer to the Amplifier and Switch manual "AMB-01-PW".

### 3.4 PORT Cable.

Connection cable between "PORT IN" and the "PORT" of the Expert amplifiers.

This cable is essential when using two Expert amplifiers (see point 5 of the previous paragraph).

If the distances between the amplifiers and the Combiner are greater than the standard cable length, you can proceed as follows:

- a) Build an extension for the part of the cable to be extended.
- b) Build a new cable with the right lengths.

All according to the following diagram.

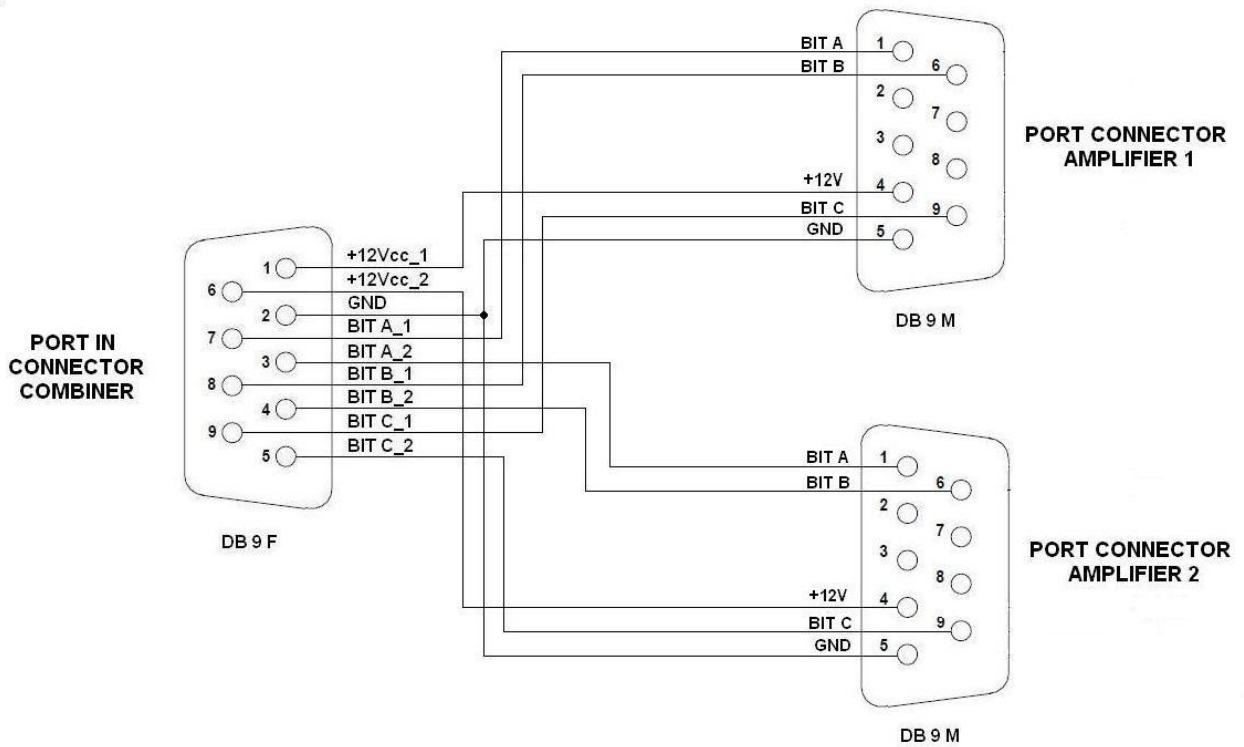

### 3.5 CAT Cable.

Connection cable between the "CAT 1" and "CAT 1" of each of the Expert amplifiers. This cable is essential when using two Expert amplifiers (see point 6 of the previous paragraph).

General reference diagram for cable design.

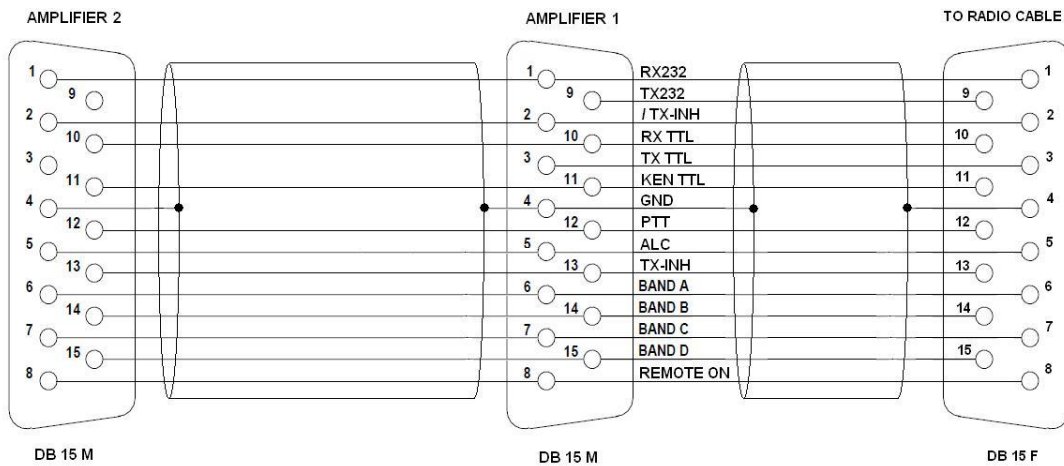

CAT Cable / CAT (to be chosen in the kit, see page 9).

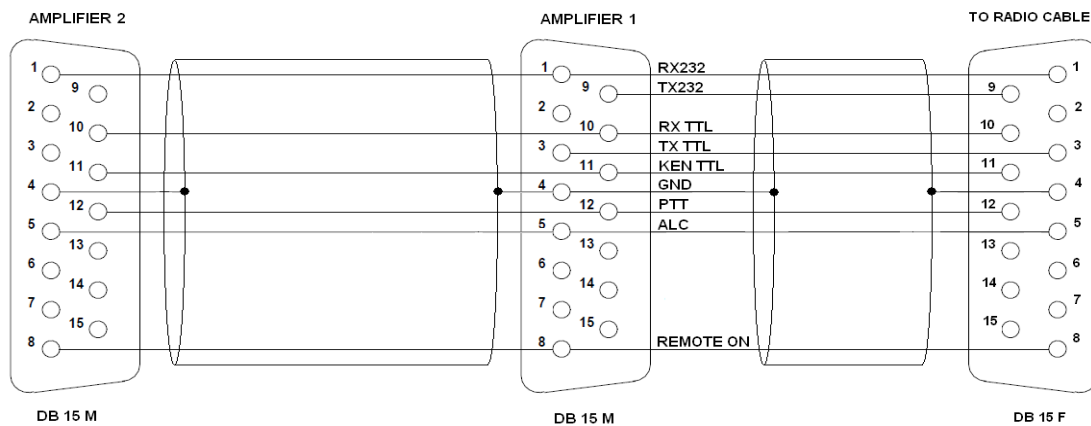

CAT Cable / BAND DATA (to be chosen in the kit, see page 9).

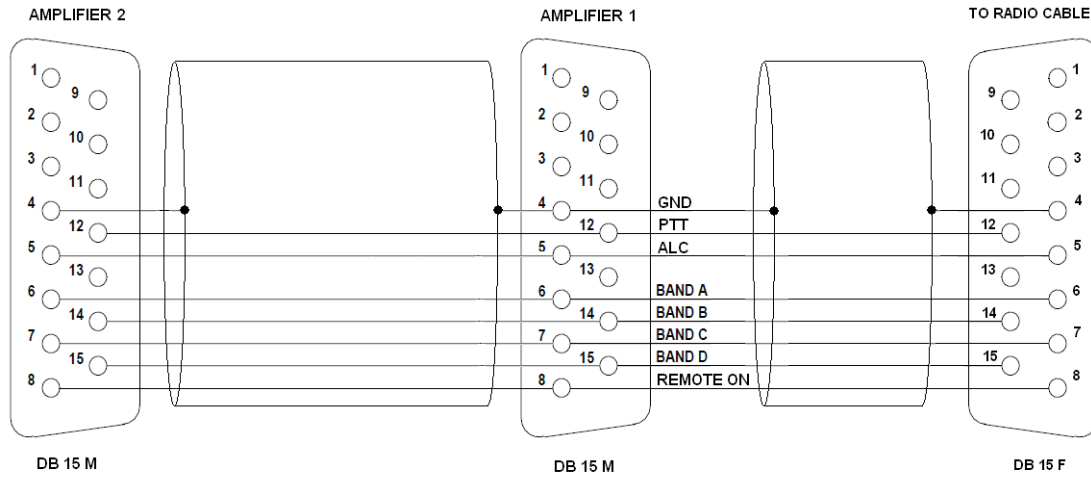

If the distances between the amplifiers and the Combiner are greater than the standard cable length, you can proceed as follows:

- a) Build an extension for the part of the cable to be extended.
- b) Build a new cable with the right lengths.

### 3.6 CAT, ALC, PTT cables without PC.

To be built if the old CAT cable is not available (see chap. 3.3 point 6).

The radio connectors are described in the specific manual.  
Check whether the RTS-CTS jumper, if any, is required or not.

*Note: WARNING, SPE is not responsible for any hardware fault resulting from incorrect interfacing.*

#### PTT, ALC, CAT Icom CI-V cables

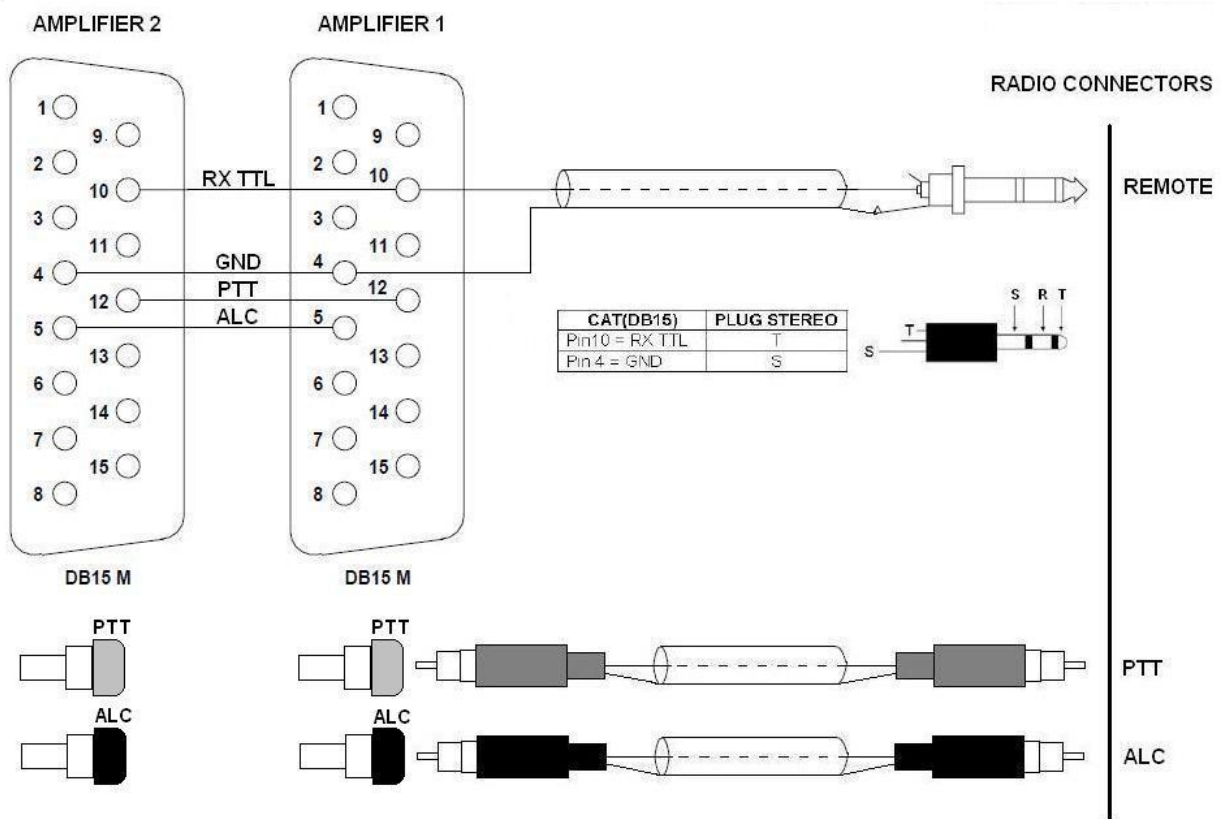

This interface is standard for all Icom models equipped with CAT, the cable always ends with a 3.5 mm mono plug.

It is also possible to use a stereo plug as shown in the diagram.  
The plug is inserted into the "Remote" connector of the transceiver.  
Set "CI-V Output (for ANT) ON" (if present) on its menu.  
Set "CI-V Transceive ON" in the transceiver menu.

The PTT and ALC cables have RCA connectors and are supplied with the amplifiers.  
They can be inserted in the sockets of either the first or of the second amplifier.

PTT, ALC, CAT RS 232 cables.

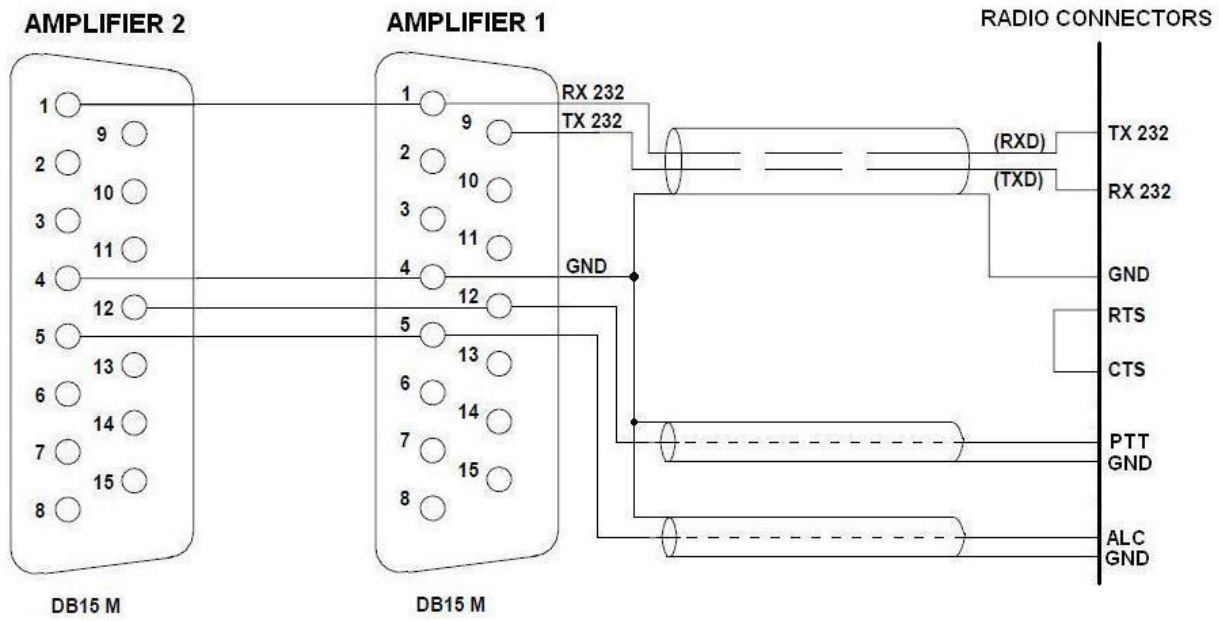

PTT, ALC, CAT TTL Yaesu cables.

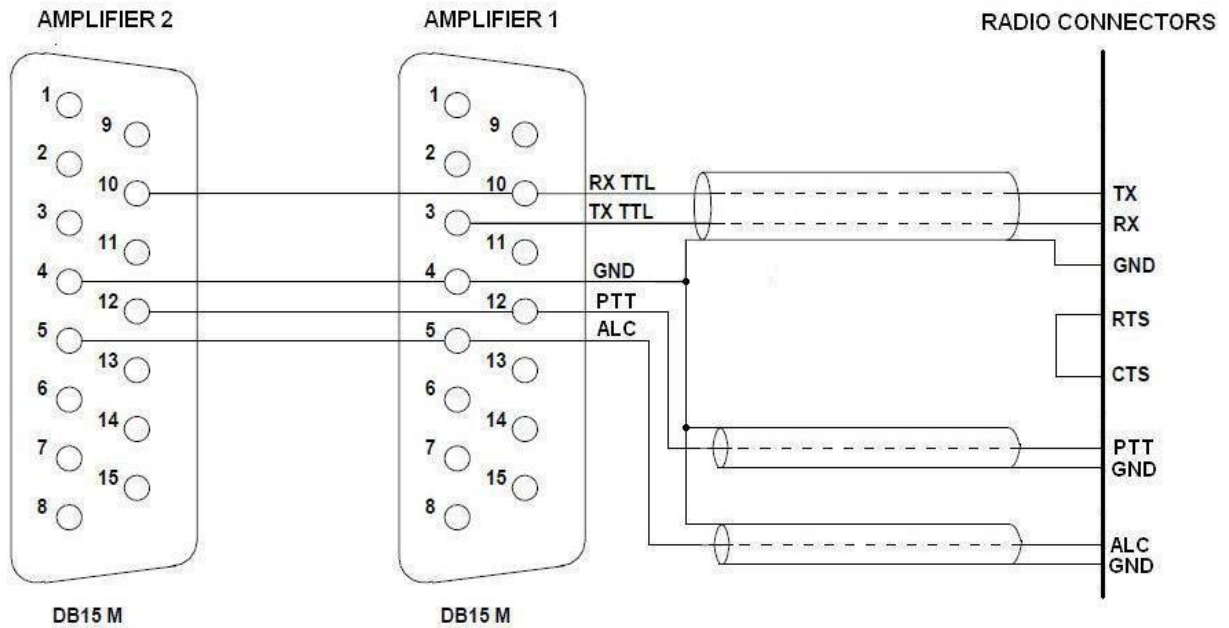

PTT, ALC, CAT TTL Kenwood cables.

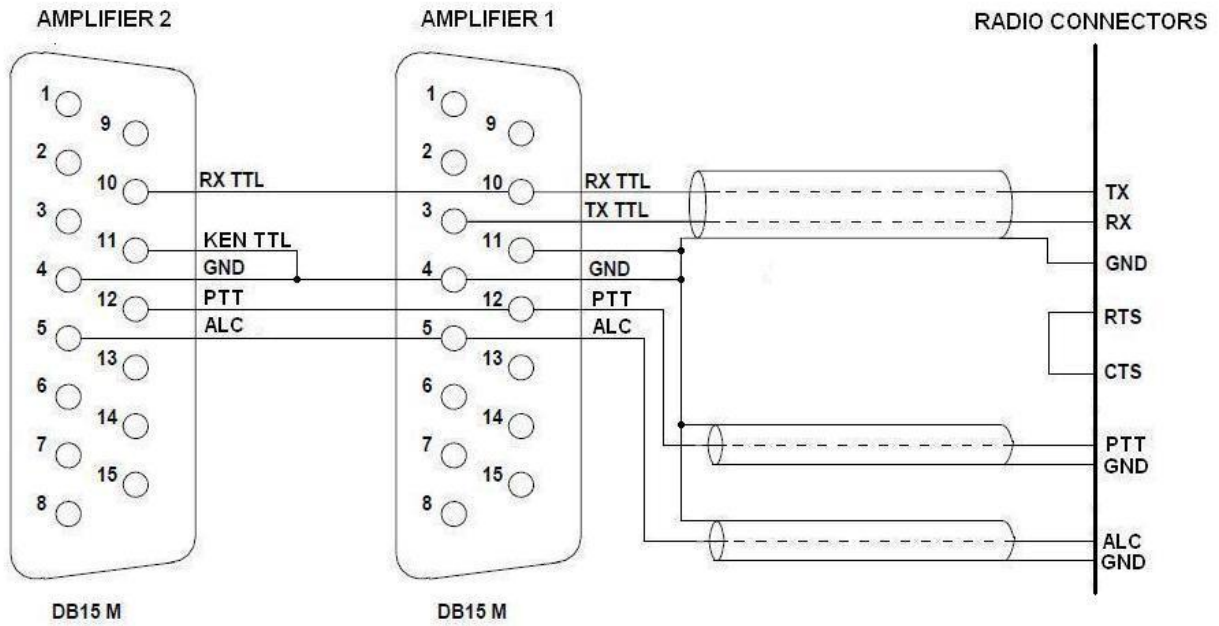

PTT, ALC, CAT BAND DATA cables.

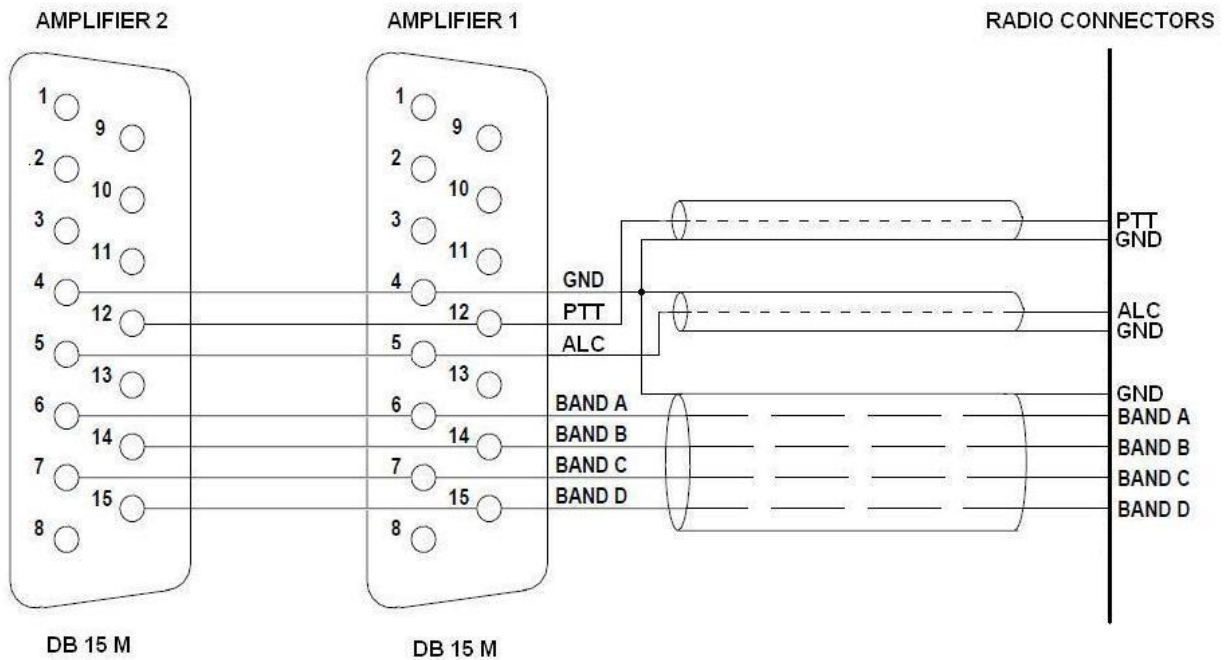

In the absence of CAT, the band is controlled by four digital signals (Band A, Band B, Band C, Band D), see specific manual.

### 3.7 CAT, ALC, PTT cables with PC.

To be built if the old CAT cable is not available (see chap. 3.3 point 6).

The connection with a PC is used to supply the station LOG with the frequency in use.

The radio connectors are described in the specific manual.  
Check whether the RTS-CTS jumper, if any, is required or not.

*Note: WARNING, SPE is not responsible for any hardware fault resulting from incorrect interfacing.*

PTT, ALC, CAT Icom CI-V cables.

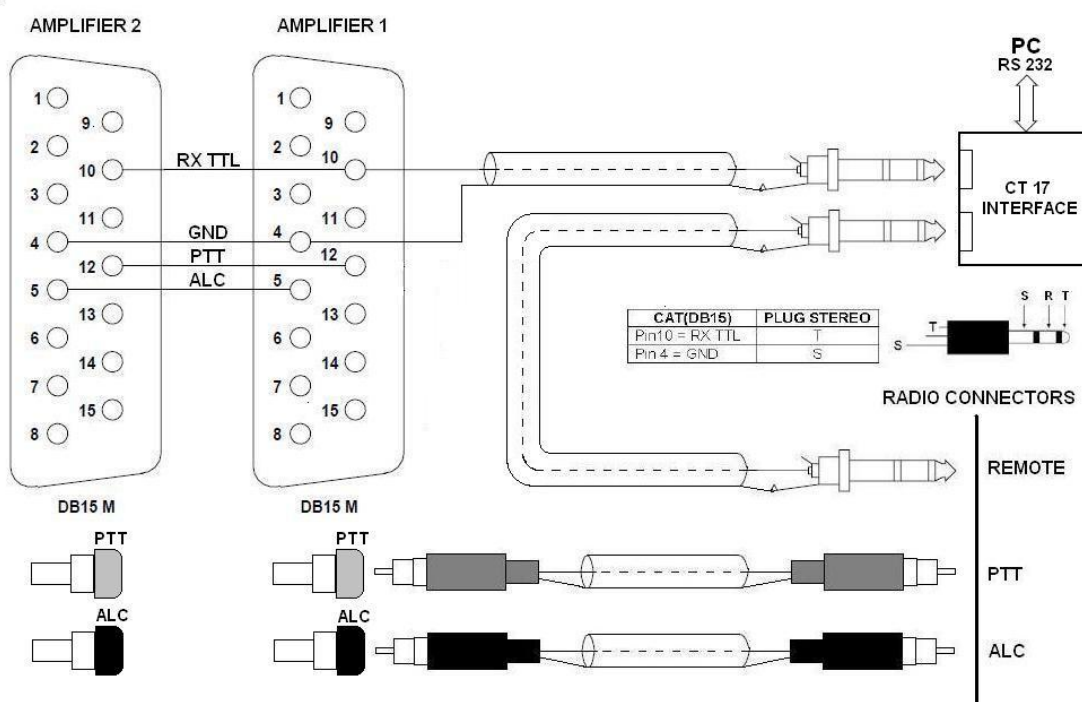

This interface is standard for all Icom models equipped with CAT, the cable always ends with a 3.5 mm mono plug.

It is also possible to use a stereo plug as shown in the diagram.

The plug is inserted into the "Remote" connector of the transceiver.

Set "CI-V Output (for ANT) ON" (if present) on its menu.

Set "CI-V Transceive ON" in the transceiver menu.

The PTT and ALC cables have RCA connectors and are supplied with the amplifiers. They can be inserted in the sockets of either the first or of the second amplifier.



PTT, ALC, CAT RS 232 cables.

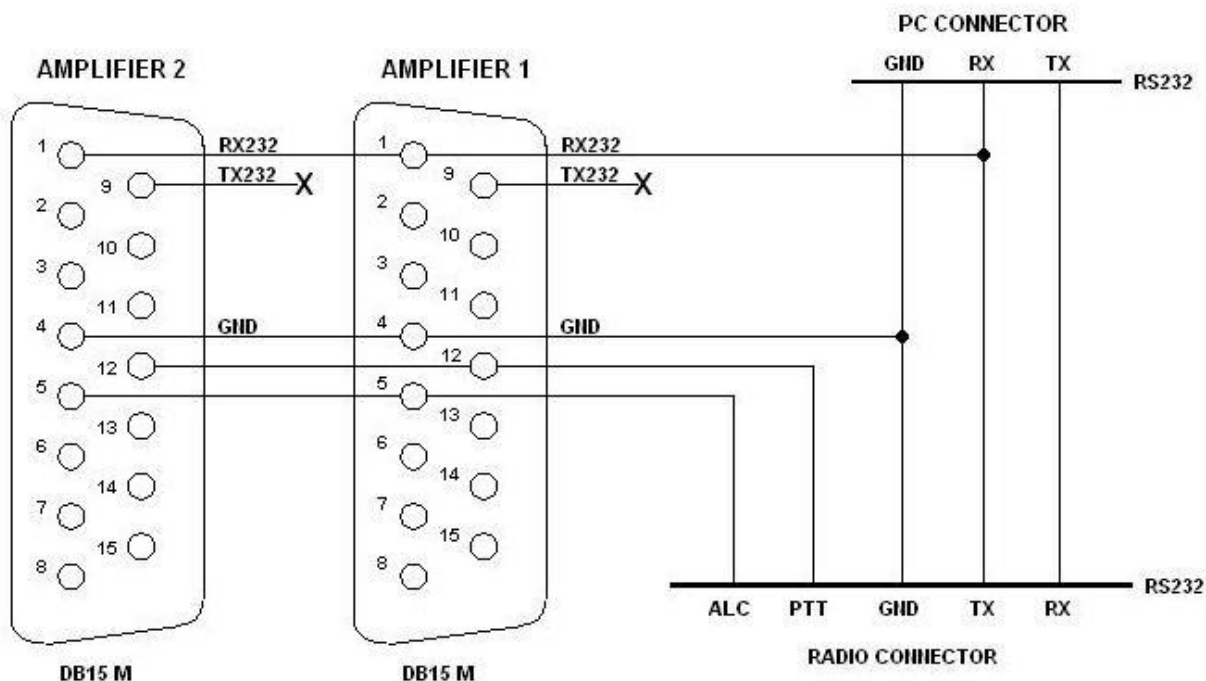

PTT, ALC, CAT TTL Yaesu cables.

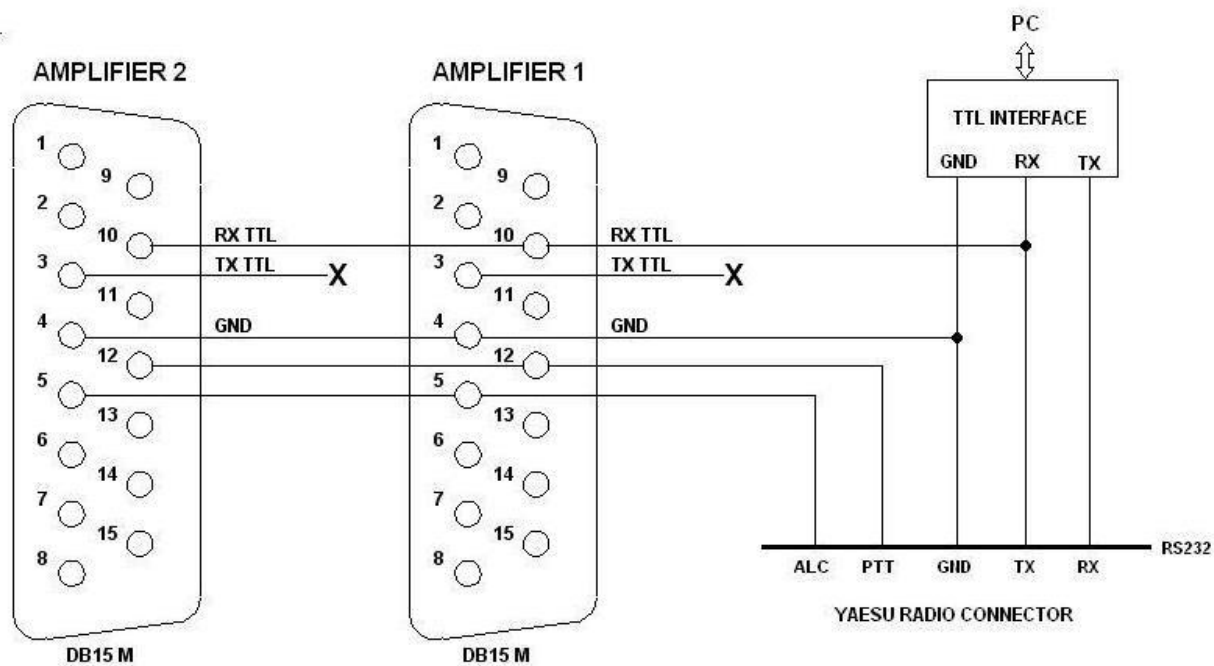

PTT, ALC, CAT TTL Kenwood cables

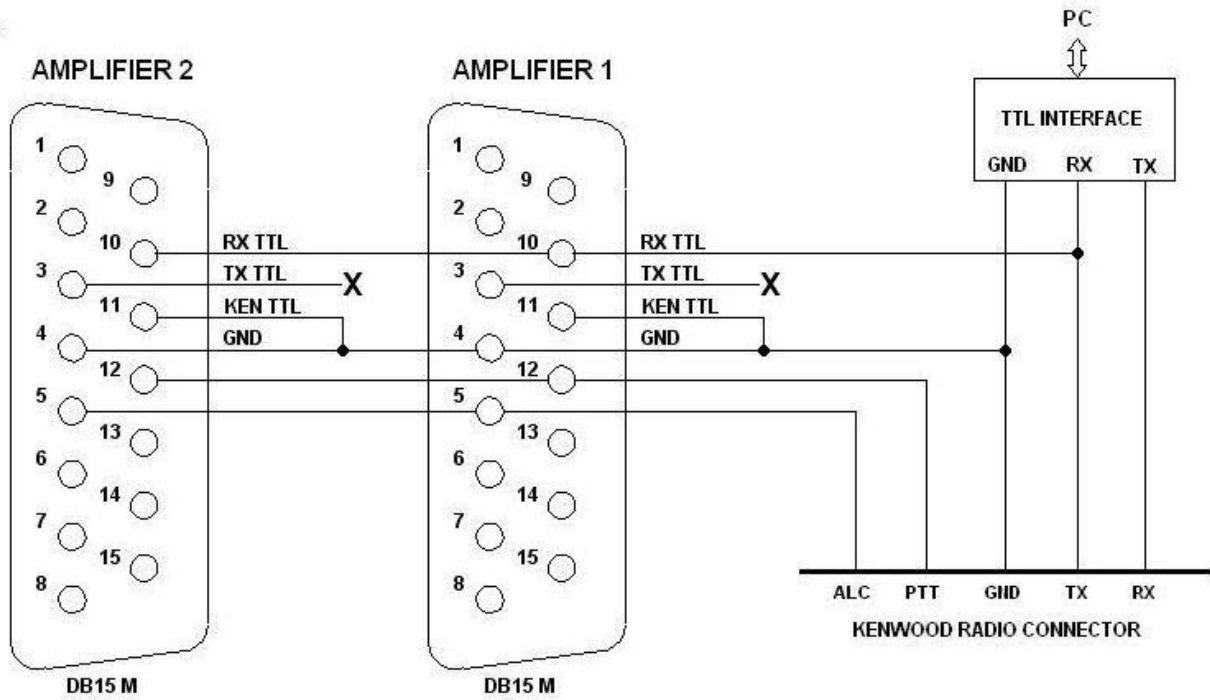

## 4. INITIAL OPERATION

### 4.1 Synchronization of the Amplifiers.

After making all the connections as specified in chap. 3.3, it is necessary to verify that both the Expert amplifiers are set up in the same way by checking that:

- I. "Combiner" is selected in the CONFIG menu and preferably the same memory bank.  
*Note: with the "Combiner" selected, at the start-up the two amplifiers are placed in "LOW" in order to synchronize their two powers.*
- II. The settings in the ANTENNA menu are completely identical (VERY IMPORTANT !).
- III. The same CAT is set with the same protocol and bit / rate in the CAT menu.
- IV. In every other menu item all settings are identical.
- V. Both amplifiers have the same firmware release.

**CAUTION:** As the **EXPERT 1K-FA** and **EXPERT 2K-FA** amplifiers do not have the CONFIG menu, and therefore do not have the "COMBINER" menu item which automatically directs all bands to the ANT1 as in EXPERT 1.3K-FA and EXPERT 1.5K-FA, you have to set the ANT1 for all the bands manually in the amplifier ANTENNA menu.

The antenna in use - or a Switch (manually) - can always be connected to the ANTENNA connector of the Combiner (see chapter 3.3 point 2).

The synchronism between the amplifiers is constantly monitored by the Combiner, and if for some reason it is lost, an alarm is immediately issued (chapter 2.7).

**This unique feature is achieved by using the "PORT CABLE".**

**The CAT and ALC connections are strongly recommended as they are of fundamental importance for the correct functioning of the Combiner.**

The **CAT** allows for the perfect band / frequency synchronization of the two amplifiers even during receiving periods, allowing optimal use of the ATU and the management of the antennas.

Without this fundamental connection, the two amplifiers would be placed on the working frequency only at the first transmission due to the internal frequency recognition. Operating at full power is very risky, especially if the two amplifiers have not initially been synchronized.

Without a CAT connection, it is recommended to make the band changes in Standby to avoid the risk of damaging one of the amplifiers.

In relation to SPE EXPERT amplifiers, thanks to the unique use of the **ALC**, any output difference between the two amplifiers is automatically reduced to the minimum (the higher output is reduced to around that of the less powerful amplifier) in order to make the dissipation in the balancing resistance insignificant.

Without the use of the ALC connection, it is impossible to obtain this unique feature, and any difference between the powers of the two amplifiers is dissipated by the balancing resistance.

## 4.2 Set-up of the ATU.

For bands where the ATU is not bypassed, complete the programming in accordance with the respective antennas.

Proceed in an orderly fashion for each antenna, sub-band for sub-band; it is strongly recommended to exercise maximum accuracy, not to limit only to the transmission frequency of the moment.

Tuning all the antennas in all the bands available will maximize the benefits of all the automatisms offered by the linear.

Proceed as follows:

- 1) In the table (see chapter "19. TABLE" of the amplifier manual) read the center frequency of the sub-band to be tuned and set it on the transceiver.
- 2) Press the [TUNE] key of both the amplifiers or the corresponding key in the keypad for common commands (see chapter 6).
- 3) Switch to transmission with the exciter in RTTY or FM; the two ATUs will move separately and independently until they stop at the SWR minimum for both.

In some cases the adjustment can be improved by starting again from point 2) or by going to "MANUAL TUNE" (very rare case).

- 4) Repeat the previous points for all the sub-bands of the band, including, if possible, the two sub-bands immediately outside the same band.
- 5) Repeat the previous steps for the other antenna of the same band (if present), after having selected it with the [ANT] key.

*Note: If the ALC connection is not used, it is advisable, during this operation, to set the power of the transceiver to approximately 60/80 Watts.*

*Note: Although the ATUs of the individual amplifiers have the ability to overcome high SWR rates it is advised, given the powers involved, not to work with SWR > of 1: 2.5.*

## 5. MAINTENANCE

The Combiner does not need internal maintenance as it has a cover without ventilation holes. As high voltage tubes are not used, the natural attraction of dust is eliminated. Therefore, the user only needs to periodically check and clean the air filter on the front panel.

The frequency of air filter inspection depends on how dusty the location is, and how much it is used. We recommend monthly cleaning of the filter.

Twice yearly cleaning of the fans with a soft brush is also recommended.

To clean the filter:

- a) Remove the front grid cover with the two small screws.  
Place small screws in a secure place. **DO NOT LOSE THEM.**
- b) Remove the filter and clean it with care.
- c) Reassemble the filter and the grid after having carefully cleaned the mechanical structure that holds them. Dry filter before re-installing.

*Note: Check the filter if an unexpected rise of temperature of the Combiner is noticed.*

*Note: Never operate without the filter, as dust could be deposited on the surface of the heatsink limiting its ability to cool.*

*Note: To allow the most efficient heat dissipation of the Combiner circuits, large copper parts have been used.*

## 6. REMOTE CONTROL OF THE AMPLIFIERS

The **XTerm\_CO1\_2\_USB** control software is included in the manual on the CD supplied with the supplied accessories.

With this program, it is not only possible to remotely control the display and keyboard of each amplifier, but it is also possible to load each new software release (individually).

There is also a keypad which allows the operator to simultaneously send the same command to both amplifiers.

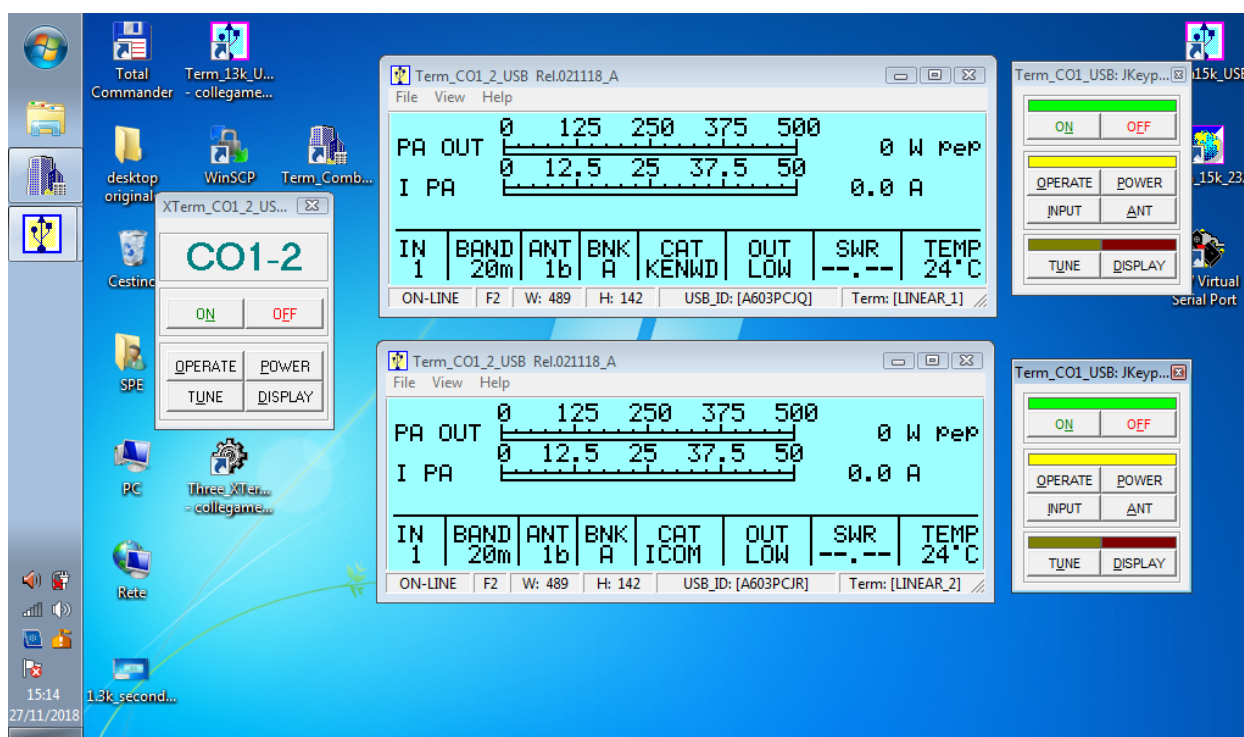

The above picture shows:

- The keypad that allows simultaneous sending of commands.
- The two displays.
- The reduced keyboards related to each amplifier; please note that you can also select the full keyboards that allow any type of setting.

## 6.1 Computer Connection.

The easiest way to proceed is to connect the two amplifiers to two different USB ports; in this way it will be very easy to intervene on one amplifier using the relative keyboard and the relative display.

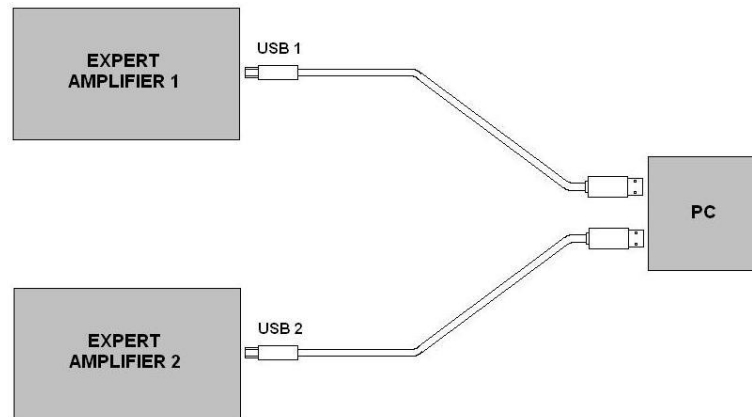

If you already have at least one Expert amplifier, installation and knowledge of the "Term" software is taken for granted. For any clarification, see the chapter:

**“APPENDIX – Remote Control - “**

of the user manual and more specifically the paragraphs:

**“ Software Installation “**

**“ Use of “Term\_USB.exe”**

## 6.2 Selective Addressing.

To use the **XTerm\_CO1\_2\_USB** it is necessary to associate each of the two Experts with a different relative address to a well-defined USB port of the PC.

This setting, based on a simple self-recognition maneuver, must be performed only once and in any case with the amplifiers previously placed in the **"OFF-LINE"** position (refer to the following pictures, as a pure example, with the use of an EXPERT 1.5K-FA).

Proceed as follows:

- 1) Open the **XTerm\_CO1\_2\_USB** SW.
- 2) Keep only one USB connection, disconnecting the other amplifier.
- 3) After opening the **File** menu in the main bar, select the **Configure USB connection** as shown in the picture below.

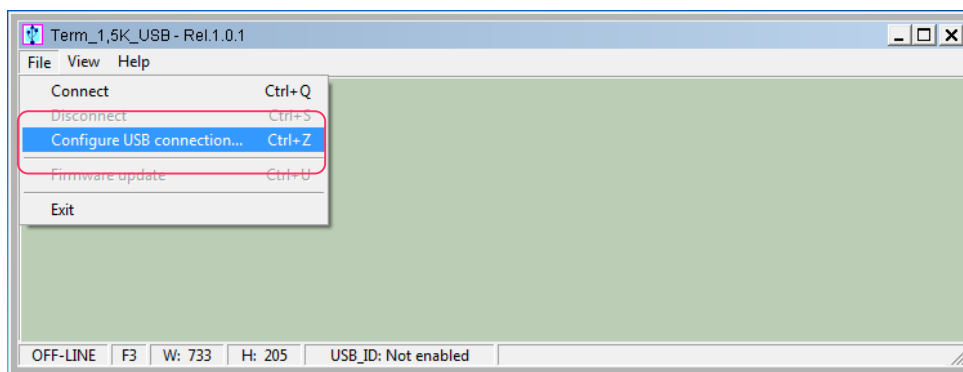

A dialog window will open like the one shown in the following picture:

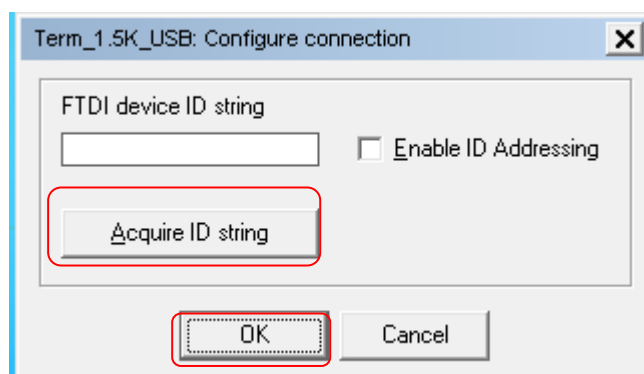

The user is simply asked to press the **Acquire ID string** key highlighted in the picture above in order to start acquiring the characters of the **ID string** via the USB connection (guided self-recognition procedure).

If there are more FT232RL connections to the system (through direct connection or via USB hub ...) refer to the amplifier manual.

When this operation has been completed successfully, disconnect the USB connection of the first amplifier and connect the other amplifier, then start again from point 3).

At the end of the operation, restore the first USB connection again.

In future it will be enough to open the program and the PC will always be able to recognize the two amplifiers.



## 7. WARRANTY TERM

SPE warrants to the original Purchaser that this product shall be free from defects of materials or workmanship.

**SPE warrants for two (2) years from the date of original purchase that SPE will provide free of charge all parts and labour necessary to correct defects in material or workmanship. The Purchaser only has to pay all the shipping expenses for warranty service work.**

Customers should address requests for warranty service work to the Distributor/Dealer where they made their purchase. As part of their reseller agreement with SPE, they are responsible for service support.

If the Distributor/Dealer has closed down, or when the Purchaser moves into another area, SPE will be directly responsible for warranty service at their factory in Rome. The shipping expenses to and from SPE will then be paid by the customer. Any repair requests to other dealers will be subject to specific direct negotiations between the customer and the dealer.

In order to not invalidate the warranty service, the original Purchaser must complete the warranty registration card, and send it to SPE within 30 days from the date of purchase. Unless otherwise agreed, the products will be delivered ex-works from the factory of the seller.

The delivery, even in the event of a return for repair, is understood to be completed with the delivery of the goods to the carrier specified by the Purchaser or, failing that, to the carrier chosen by SPE.

The products will travel at the risk of the Purchaser even if, at the request of the same one or for other causes, SPE should carry out transport or choose the carrier.

If the original Purchaser finds some defects after having received the equipment, he must immediately notify the Distributor/Dealer of the defects found by sending a properly completed description. Replacement of the Combiner may be done by SPE in exceptional circumstances and at SPE's complete discretion. In any case no replacement will be provided if more than 20 days have passed after initial delivery.

In case of a purchase of a used combiner, in order to retain the warranty's validity, it is necessary to notify SPE of the following data:

- Document for the second purchase (used).
- Invoice for the original purchase.
- Serial number (s/n) of the equipment.

Replacement of equipment in these circumstances is not an option.

In any case the warranty period shall be two (2) years from the original purchase, and not from any subsequent purchase.

If cases where the date of first sale is not well specified or is more than one year from the date of shipping from SPE to the Distributor/Dealer, the date of shipping from SPE to the Distributor/Dealer will be considered the start of the warranty period.

The warranty does not apply either if the certificate of the first purchase (invoice) is missing, the s/n is undecipherable / falsified or to any defect that SPE determines is due

to:

1. Improper maintenance or repair by persons not authorised by SPE to carry out such work, including the installation of parts or accessories that do not conform to the quality and specifications of the original parts.
2. Misuse, abuse, neglect or improper installation, non-observance of user manual.
3. Carelessness, accidental or intentional damage.

SPE warrants aforesaid items only, and the Purchaser shall have no remedy and no claim for incidental or consequential damages.

It is mandatory, when sending SPE equipment to be repaired, to enclose:

- Invoice of the original purchase.
- Document of the second purchase (if any).

Particular agreements between retailer and Purchaser or particular obligations imposed in other countries are matters for the local retailer and not for SPE.

In the event of dispute, Rome's court of competent jurisdiction will apply.

**By purchasing SPE equipment, the Purchaser declares his acceptance of the above Warranty Terms.**

**SPE** s.r.l.

Via di Monteverde, 33 00152 Roma

Tel. +390658209429 (r.a.)

Fax. +390658209647

E-mail: [info@linear-amplifier.com](mailto:info@linear-amplifier.com)

Website: <http://www.linear-amplifier.com>