

INJET ECO

AC EV Charging station



**User
Manual**



UM20102R03-1-2024

About this User Manual

- ▷ Failure to read this manual carefully may lead to improper operation.
- ▷ Failure to follow the safety notes may lead to a danger of death, injury and damage to the device, supplier cannot accept any liability for claims resulting from this.

Thank you very much to use our INJET ECO AC EV Charging Station.

- ▷ This manual describes the installation, use and maintenance of INJET ECO AC EV Charging station. This manual is intended for installation, maintenance personnel and terminal customer.

Article	Model Number (UK)
1-phase, 7kW, Untethered	iMHN-07KO-BAUK / iMHN-07KO-BBUK/ iMHN-07KO-BCUK
3-phase, 22kW, Untethered	iMHN-22KO-BAUK / iMHN-22KO-BBUK/ iMHN-22KO-BCUK
1-phase, 7kW, Tethered	iMHN-07KO-CAUK / iMHN-07KO-CBUK/ iMHN-07KO-CCUK
3-phase, 22kW, Tethered	iMHN-22KO-CAUK / iMHN-22KO-CBUK/ iMHN-22KO-CCUK

- ▷ The text and illustrations in this user manual are general explanations of these type of equipment, and the actual product may be inconsistent with this manual in detail.

All rights reserved.

CONTENTS

1.	ABBREVIATIONS	5
2.	SAFETY NOTES	6
2.1.	Safety signs used	6
2.2.	Environment	7
2.3.	Installation	7
2.4.	Operation	8
2.5.	Maintenance	8
3.	STANDARDS COMPLIANCE	9
3.1.	Charging mode	9
3.2.	Charging Control Method & Explanation	9
3.3.	Charging connection	9
3.4.	Charging interface	10
3.4.1.	INJET ECO Socket Version series	10
3.4.2.	INJET ECO Plug & Cable Version series	11
4.	PRODUCT INFORMATION	12
4.1.	General	12
4.2.	Model number definition	13
4.3.	Specifications	13
4.3.1.	Electrical specifications	13
4.3.2.	Functional description	14
4.3.3.	Ambient conditions	15
4.3.4.	Mechanical parameters	15
4.4.	Nameplate	15
5.	INSTALLATION	16
5.1.	Unpacking	16
5.1.1.	Packing list	16
5.1.2.	Inspection & confirm	16
5.2.	Prepare	17
5.3.	Power supply system	19
5.4.	Installation steps	20
5.5.	Empty socket	26
5.6.	Installation of 4G charging station (Optional)	26
6.	OPERATION	28
6.1.	Power on	28
6.2.	Human-Machine Interface	28
6.2.1.	Overview	28
6.2.2.	LED indicators	29
6.2.3.	RFID reader	29
6.2.4.	Charging control button	30
6.3.	Start Charging	30
6.4.	Normally stop charging	31
6.5.	Abnormally stop charging	31
6.6.	Configure parameters	32

7. FAULT HANDLING AND MAINTENANCE	- 35 -
7.1. Fault Handling	- 35 -
7.2. Maintenance.....	- 37 -
8. Appendix	- 37 -
8.1. OPTIONAL FUNCTIONS.....	- 37 -
8.1.1.Solar charging + Dynamic load balance via smart meter	- 37 -
8.1.2.Dynamic load balance via APCC.....	- 41 -
8.1.3.Dynamic load balance via 485 CT Current Transformer	- 43 -
8.1.4.Dynamic load balance via Power Sharing	- 43 -
8.1.5.Meter logic	- 45 -
8.2. Pole Mounting Installation Guide	- 46 -
WARRANTY AGREEMENT	- 48 -
CONTACT INFORMATION.....	- 49 -
COMPLIANCE STATEMENT OF WEEE.....	- 50 -
DECLARATION OF CONFORMITY(DOC).....	- 51 -

1. ABBREVIATIONS

S/N	Abbreviations	Description
1	IEC	International Electrotechnical Commission
2	EV	Electrical Vehicle, this can be BEV (battery EV) or PHEV (plug-in hybrid EV)
3	EVSE	Electric Vehicle Supply Equipment [IEC61851-1]
4	OBC	On-board charger (of an EV)
5	LCD	Liquid Crystal Display
6	LED	Light-emitting Diode
7	RFID	Radio Frequency Identification
8	CMS	Central Management System
9	OCPP	Open Charge Point Protocol
10	IP	Ingress Protection
11	HMI	Human-Machine Interface
12	RCMU	Residual Current Monitoring Unit
13	MCB	Miniature Circuit Breaker
14	TN	<p>"T" — indicates the connection between earth and the power supply is direct connection of a point with earth (French: Terre).</p> <p>"N" — the earth connection is supplied by the electricity supply network, either separately to the neutral conductor (TN-S), combined with the neutral conductor (TN-C), or both (TN-C-S).</p> <div style="display: flex; justify-content: space-around;"> <div style="text-align: center;"> <p>TN-S system 230/400VAC</p> </div> <div style="text-align: center;"> <p>TN-C system 230/400VAC</p> </div> <div style="text-align: center;"> <p>TN-C-S system 230/400VAC</p> </div> </div>
15	PE	Protective Earth. The conductor that connects the exposed metallic parts of the consumer's electrical installation
16	PEN	PEN line is to accurately and well ground the original neutral line, and connect the shell of the equipment to be protected to the PEN line

2. SAFETY NOTES

2.1. Safety signs used

The following warning signs, mandatory signs and information signs are used in this manual, on and in INJET ECO AC EV Charging station.



CAUTION: Warning of electrical hazards.
This sign is intended to alert the user that severe personal injury or substantial property damage can result if the device is not operated as requested.



ATTENTION: Warning of a danger spot or dangerous situation.
This sign is intended to alert the user that minor personal injury or material damage can result, if the device is not operated as requested.



CAUTION: Do not touch by hands in case of ESD.
Indicates the possible consequences of touching electrostatically sensitive components.



CAUTION: Warning of combustion.



No access for unauthorized persons.



No access for persons wearing pacemakers.



Use protective footwear.



Must wear a safety helmet.



Indicates important texts, notes or tips.



Indicates recycling information.



Indicates assemblies or parts that must be disposed of properly.
Do not dispose of them in the household waste.

2.2. Environment



- ▷ EV Charging station should be installed on the incombustible such as concrete; otherwise, hazardous fire may result.
- ▷ EV Charging station should not be installed in the area that contains explosive gas; otherwise, hazardous blast may result.
- ▷ Leave no inflammable or explosive substances near the EV Charging station; otherwise, hazardous blast may result.



- ▷ EV Charging station should be installed in a place with no conductive dust and insulation-destructive gas or vapor.
- ▷ EV Charging station should be installed in a place with no violent vibration and impact; for good ventilation, mount the charging station vertically.
- ▷ The installation foundation shall be higher than the ground level, and drainage ditch shall be set around the EV Charging station, otherwise the equipment may be damaged.

2.3. Installation



Safety protection must be done when installing the EV Charging station.



- ▷ Installation and wiring should be done by personnel with professional qualification, otherwise, hazardous electric shock may result.
- ▷ Make sure input power supply is entirely disconnected before wiring; otherwise, hazardous electric shock may result.
- ▷ PE terminal of the EV Charging station must be grounded securely; otherwise, hazardous electric shock may result.
- ▷ The lead nose of the charging station must be securely attached or there is a risk of damaging the equipment.
- ▷ Leave no metals such as bolts, gaskets into the inside of the EV Charging station; otherwise, hazardous blast and fire may result.



- ▷ Main loop terminal of the EV Charging station should be firmly connected with the wiring ends; otherwise, damage to property may result.
- ▷ Bare parts of wiring ends of electrical cables must be wrapped with insulating tape; otherwise, hazardous fire and property loss may result.

2.4. Operation



- ▷ Strictly forbidden for minors or persons of restricted capacity to approach the charging station to avoid injury.
- ▷ Forced charging is strictly forbidden when the electric vehicle or charging station fails.



- ▷ It is strictly prohibited to use the charging station when the charging adapter or charging cables are defective, cracked, worn, broken or the charging cables is exposed. If you find any, please contact the supplier in time.
- ▷ EV can only be charged with the engine off and stationary.



- ▷ Do not charge in rainy and thunderous weather.

2.5. Maintenance



Personnel must always use protective footwear when maintenance work. Caution ESD to avoid damaging electronic devices, especially to protect microchips on PCBA.



- ▷ Accessory replacement must be done by qualified personnel, thrums or metals are prohibited to be left in the controller; otherwise, hazardous blast and fire may result.
- ▷ After replacing main PCBA, parameters must be adjusted and matched before operation; otherwise, property loss may result.



- ▷ It is recommended that routine safety inspection visits to charging station be conducted at least once a week.
- ▷ Keep the charging connector clean and dry and wipe with a clean, dry cloth if soiled.

3. STANDARDS COMPLIANCE

3.1. Charging mode

- Conformed to *EN IEC 61851-1:2019*



Charging mode:

method for connection of an EV to the supply network to supply energy to the vehicle

- The Charging mode of INJET ECO series product is Mode 3



Mode 3 is a method for the connection of an EV to an AC EV supply equipment permanently connected to an AC supply network, with a control pilot function that extends from the AC EV supply equipment to the EV.

3.2. Charging Control Method & Explanation

- RFID Control: The master card could start and stop charging when charger is power on.
- Button control: Could enable and disable the button control on offline configuration page or on the WE E-Charge app.
- WE E-Charge APP control: Could use WE E-Charge app control the charger when it connect with internet.
- Third party APP control: You can use a third-party app to control the charger when it configure with a third party OCPP server. Such as Ampeco, AmpUp and etc.

3.3. Charging connection

- According to *EN IEC 61851-1:2019*, INJET ECO series products meet the Tethered connection.



Tethered:

Connection of an EV to a supply network utilizing a cable and vehicle connector permanently attached to the EV charging station.

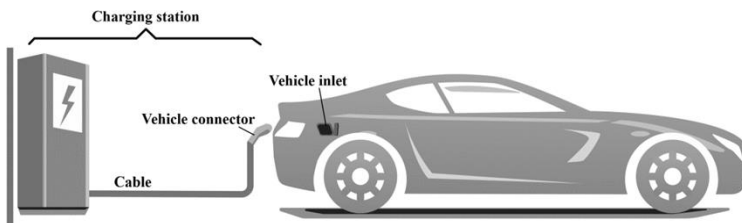

Fig. 3-1 Schematic diagram of TETHERED connection

- According to EN IEC 61851-1:2019, INJET ECO series products meet the Untethered connection.



Untethered:
 Connection of an EV to a supply network with a cable assemble detachable at both ends.

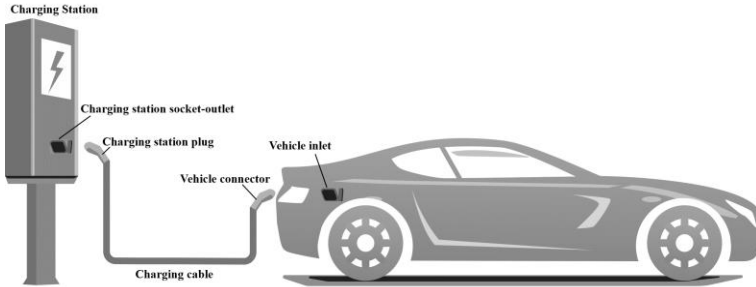

Fig. 3-2 Schematic diagram of UNTETHERED connection

3.4. Charging interface

3.4.1. INJET ECO Socket Version series

- The charging connector of INJET ECO Untethered series meet IEC 62196-2, Type 2 plug (without charging cable).

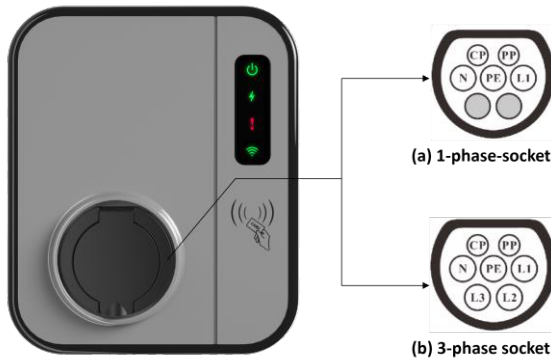

Fig. 3-3 Schematic diagram of Type 2 socket on INJET ECO Series Product

- INJET ECO Untethered series can charge an EV with a Type 1 or Type 2 vehicle inlet. Users should extra purchase a dual-connector charging cable shown as Fig. 3-4, according to the vehicle charging inlet of their EV. One connector of the charging cable must be a Type 2 male plug, and another is a Type 1 or Type 2 female plug to EV.

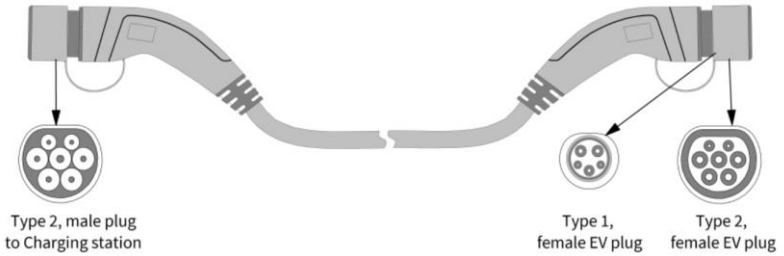

Fig. 3-4 Dual-connector charging cable

3.4.2. INJET ECO Plug & Cable Version series

- The charging connector of INJET ECO meet IEC 62196-2, Type 2 plug (with charging cable).

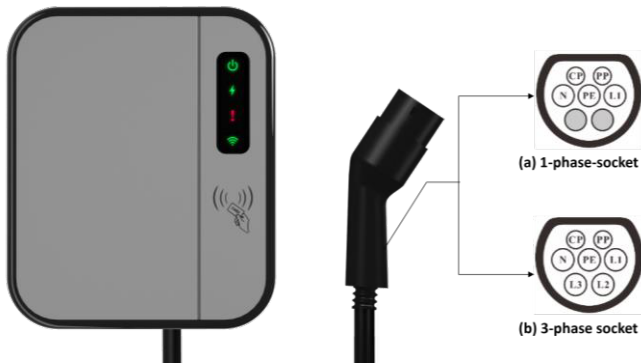

Fig. 3-5 Schematic diagram of Type 2 plug on INJET ECO Series Product

- INJET ECO provides a Type 2 female plug with charging cable, it only charging an EV with a Type 2 vehicle inlet.

4. PRODUCT INFORMATION

4.1. General

Welcome to use INJET ECO AC EV Charging station produced by our company.

- The shape & dimensions of INJET ECO AC EV charging station shown as Fig. 4-1.

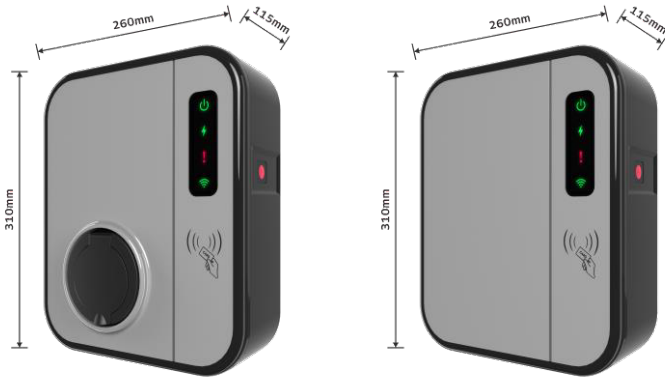

Fig. 4-1 The shape & dimensions of INJET ECO

- The block diagram of INJET ECO AC EV charging station is shown as Fig. 4-2.

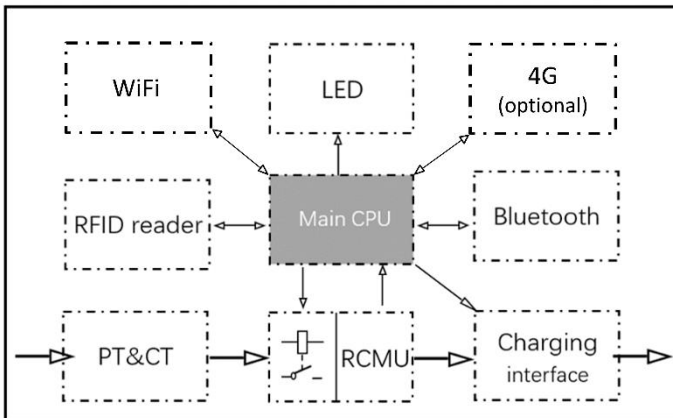

Fig. 4-2 Block diagram of INJET ECO

- It is widely used in all kinds of household electric vehicle charging, as well as various charging stations, parking lots, community garages and public electric vehicle charging places.

4.2. Model number definition

The model number definition of INJET ECO follows the rules as shown in Fig. 4-3.

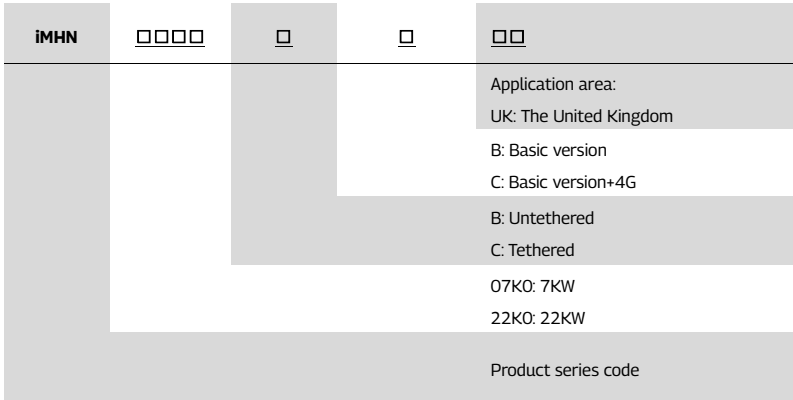

Fig. 4-3 Model number definition

4.3. Specifications

4.3.1. Electrical specifications

- INJET ECO Socket Version Series

Phase Number	1-Phase	3-Phase
Model Number	iMHN-07K0-BB** iMHN-07K0-BC**	iMHN-22K0-BB** iMHN-22K0-BC**
Rated Voltage	230V, 50Hz	400V, 50Hz
Rated Current	32A	32A
Rated Power	7kW (@230V, 1-phase)	22kW (@400V, 3-phase)
Recommended power supply cable	3×6mm ² , copper	5×6mm ² , copper
Input Terminals	L1/ N/ PE	L1/L2/L3/N/PE
Charging interface	Type 2, 1-phase socket	Type 2, 3-phase socket

■ INJET ECO Plug & Cable Version Series

Phase Number	1-Phase	3-Phase
Model Number	iMHN-07KO-CB** iMHN-07KO-CC**	iMHN-22KO-CB** iMHN-22KO-CC**
Rated Voltage	230V, 50Hz	400V, 50Hz
Rated Current	32A	32A
Rated Power	7kW (@230V, 1-phase)	22kW (@400V, 3-phase)
Recommended power supply cable	3×6mm ² , copper	5×6mm ² , copper
Input Terminals	L1/ N/ PE	L1/L2/L3/N/PE
Charging interface	Type 2, 1-phase plug with 5m cable	Type 2, 3-phase plug with 5m cable

4.3.2. Functional description

Version Name	UK Version
Charging Control Mode	Local: "Plug-and-play", "Button-controlled" or "RFID Card-controlled", "NFC analogue card control" Remote: "APP-control", "OCPP protocol control"
Indicator Lights	4 LED lights; indicate 4 statuses include power, charging, fault and network
Safety Protection	Surge Protection, Ground Fault Protection, Overvoltage Protection, Overcurrent Protection, Overheat Protection, Output short circuit Protection, PEN, tamper-protection boundary
RCMU Built-in	Yes, built-in a RCMU with Type A 30mA + DC 6mA
Communication Interface	One channel of RS-485(For external smart energy meter or DLB), WiFi 2.4GHz+ WiFi 5GHz, Bluetooth, 4G (Optional)
Communication Protocol	OCPP 1.6J full+ Security 3, MODBUS RTU

4.3.3. **Ambient conditions**

Product Name		INJET ECO
Altitude	≤ 2000m	
Storage temperature	-40 ~ 80℃	
Operation temperature	-30 ~ 50℃	
Relative humidity	≤ 95%RH, no condensation	
Vibration	< 0.5G, no acute vibration and impaction	
Installation location	Indoor or outdoor, good ventilation, no flammable, explosive gases	

4.3.4. **Mechanical parameters**

Model series		INJET ECO
Mounting	Wall-mounted or pole-mounted (mounting pole is optional)	
Net Weight	≤ 4kg	
Dimension	H×W×D = 310mm ×260mm × 115mm	
IP Code	IP65(Tethered Version) / IP55(Untethered Version)	
IK Code	IK10	

4.4. **Nameplate**

On the right side of INJET ECO shell, there is a nameplate identifying the model and specification of the charging station. As the Fig. 4-4 shown, taking IMHN-07K0-BCUK as example, the location and content of the nameplate are illustrated.

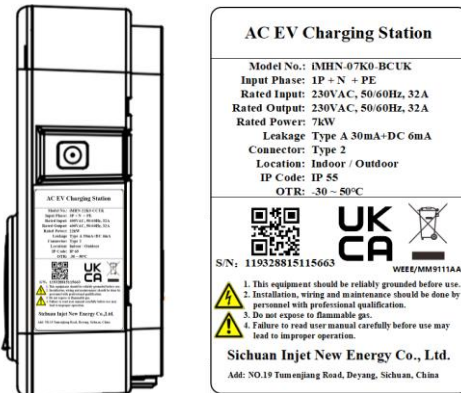

Fig. 4-4 The location and content of the nameplate

5. INSTALLATION

5.1. Unpacking

5.1.1. Packing list

Package	Quantity
AC EV Charging Station	1 pc
Cylinder lock key	2 pcs
RFID card	2 pcs
User Manual	1 pc
wall-mounting accessories (including A+B+C+D+E+F as Fig. 5-1 shown)	1 set
Quality certificate	1 pc
Empty socket (only provide for INJET ECO Plug & Cable Version series product)	1 pc
Positioning paper	1 pc

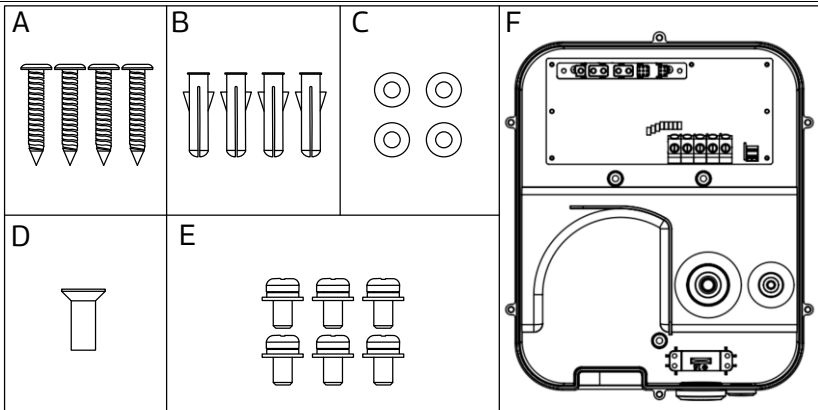

Fig. 5-1 Wall-mounting accessories

Note*: if the user purchases INJET ECO Plug & Cable Version series product, three sets of screws[A] and expansion tubes[B] are provided for mounting the empty socket.

5.1.2. Inspection & confirm

When unpacking, please carefully confirm the following points:

- Whether the accessories are missing according to the packing list.
- Whether there is any damage during transportation.
- Whether the model and specification of the machine's nameplate are consistent with the order requirements.



- ▷ If any damage or missing parts are found, please do not start the machine and contact the supplier as soon as possible.
- ▷ Please keep the packing box and packing materials 1 month for future handling.



- ▷ The paper packaging is recyclable.

5.2. Prepare

- When transporting or moving the charging station, pay attention to the following points to ensure product safety:



- ▷ This product is electrical equipment. It should be handled with care to avoid violent vibration and impact.
- ▷ The charging station shall not be transported by dragging the charging connector and the charging cable.

- In order to ensure the long-term stable operation of the product, it is recommended to avoid installing charging stations in extreme weather as far as possible, especially low or high ambient temperature may affect the installation effect due to thermal expansion and cold contraction.
- The electrical power supply cable must be prepared. Please refer to Clause 4.3.1 to select the power cable.
- Space requirement: When the charging station is fixed on the wall, the minimum space requirements are shown in Fig. 5-2.

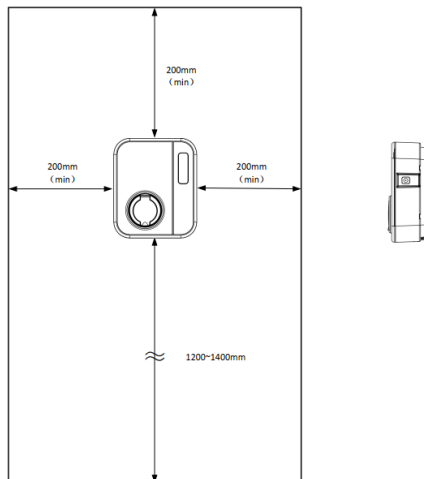









Fig. 5-2 Minimum space requirements for wall mounting

- It is suggested that INJET ECO should be installed in a place with good ventilation, no direct sunlight and shelter from wind and rain. In order to ensure good ventilation condition, you should mount INJET ECO vertically and leave enough space.

- Tools for installation

Prepare the following tools at least before installing INJET ECO AC EV charging station.

Sr No.	Tools' Name	Schematic Picture	Main Uses
1	Multimeter		Check the electrical connection and measure the voltage
2	Electric Impact drill		Drill fixing holes in the wall
3	Wrench		Fastening bolt
4	Diagonal plier		Cut the cable
5	Wire stripper		Peeling cables
6	Crimping plier		Pressed cable terminal
7	Cross screwdriver		Fastening screw

5.3. Power supply system

INJET ECO UK Version is suitable for installation in TN power supply system.

- a) TN-S power supply system wiring mode

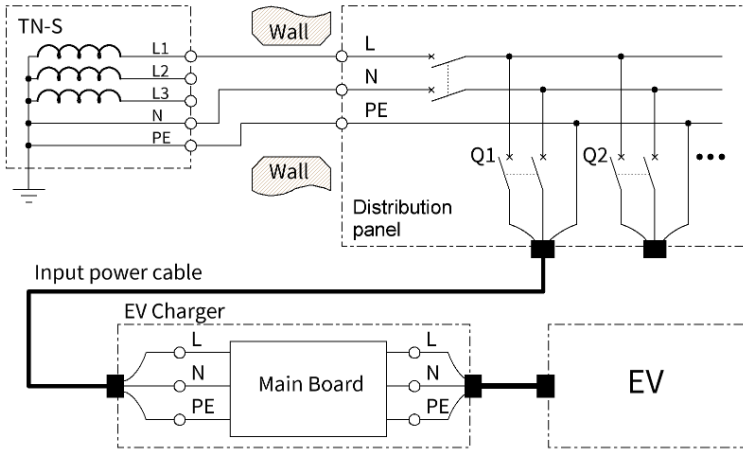

Fig. 5-3 INJET ECO work in TN-S system

- b) TN-C power supply system wiring mode

Earth rod should be installed as far as possible to ensure that household electrical equipment can be effectively protected zero connection. The Fig.5-4 shows the TN-C power supply system with earth rod.

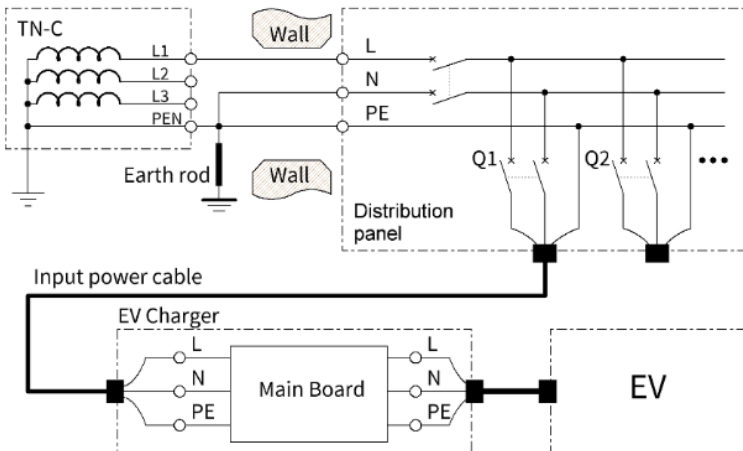

Fig. 5-4 INJET ECO work in TN-C system with earth rod

In TN-C, for local earth rod where there is no condition to install, a series of circuits are set inside INJET ECO to protect safety. Even if leakage fault occurs when PEN is disconnected or three-phase voltage is unbalanced, INJET ECO can quickly interrupt charging and protect the personal safety of users.

c) TN-C-S power supply system wiring mode

The connection method is the same as that of TN-S power supply system.

5.4. Installation steps

Install INJET ECO on the wall follow the steps as below.

■ Step 1: Drilling

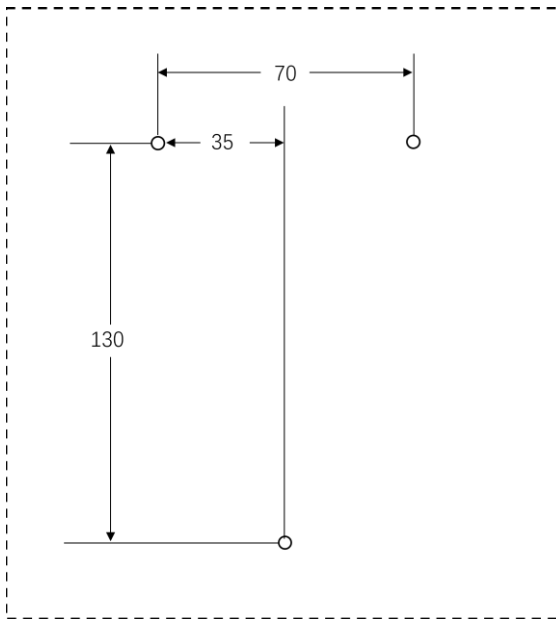

Fig. 5-5 Positioning paper

Drill 3 holes with diameter of 6mm and depth of at least 50mm on the wall using Positioning paper.

- **Step 2: Put the accessories expansion screw[B] into the holes**

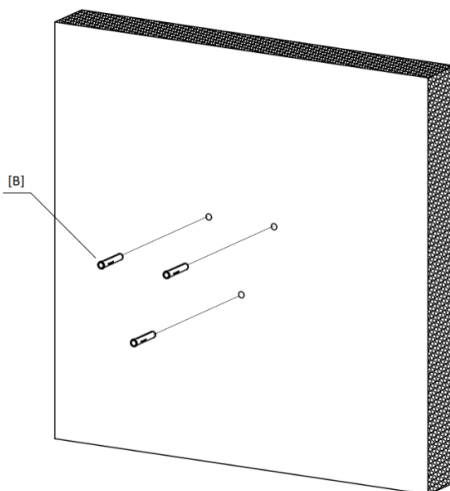

Fig. 5-6 mounting the expansion screws[B]

- **Step 3: Fix the Wall-mounting accessory[F]**

As shown in Fig. 5-7, secure the mounting accessory[F] to the wall with other accessories which contain in package.

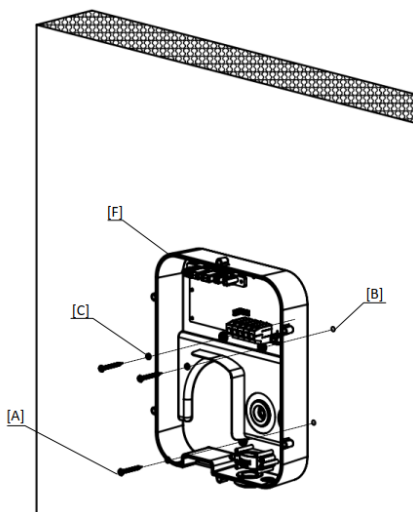

Fig. 5-7 Fix the Wall-mounting accessories-[F]

■ Step 4: Wiring

As shown in Fig. 5-8-1, pass the prepared power cable through the input cable interface, connect each cable to the input terminals according to the terminal label.

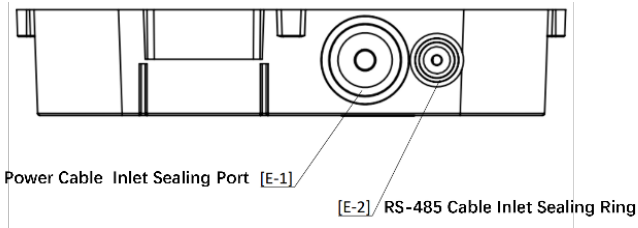

Fig. 5-8-1 Sealing interface

As shown in Fig. 5-8-1,

For single-phase chargers, connect the power cable to L1, N, and PEN.

For three-phase chargers, connect the power cable to L1, L2, L3, N, and PEN.

Connect the communication cable to A1+ and B1-(RS485).

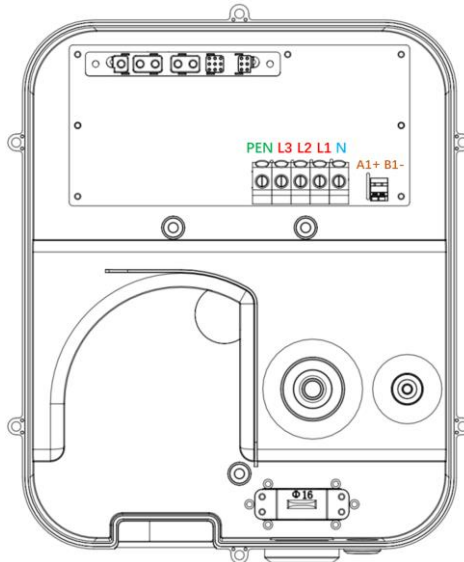

Fig. 5-8-2 Wiring

■ Step 5: Fix INJET ECO

As shown in the picture, please remove the plastic film on the back of the ECO before installation.

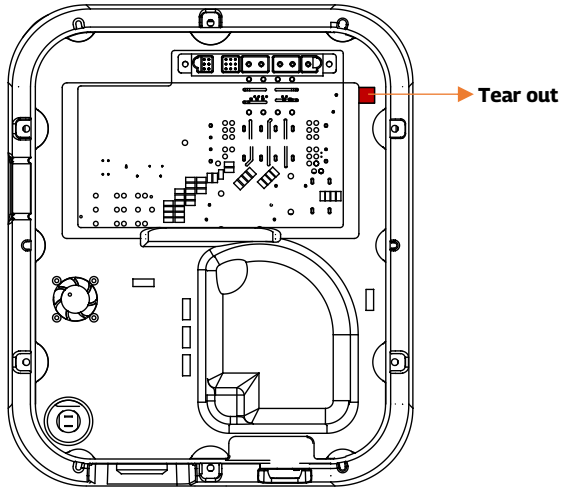

Fig. 5-9-1 remove the plastic film

As shown in Fig. 5-9-2, hang the device on the mounting accessory[F]

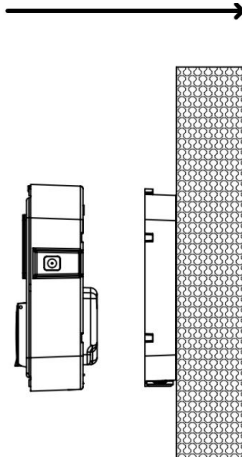

Fig. 5-9-2 hang the device on the mounting accessory[F]

■ **Step 6: Rotate the security lock 90° to the right**

Rotate the security lock 90° to the right to avoid the risk of the housing falling off before the installer inserts the housing without the screws.

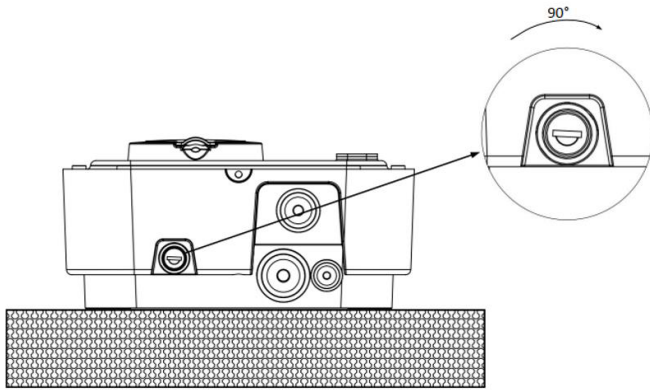

Fig. 5-10 Rotate the security lock 90° to the right

■ **Step 7: Install the six screws [E] shown below**

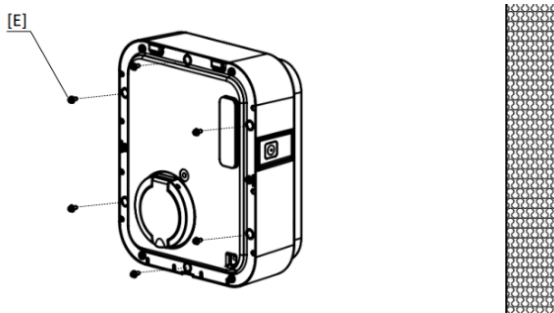

Fig. 5-11 Install the screws [E]

■ **Step 8: Installation of decorative cover**

When installing the decorative cover, please note that there is a hook at the top of the decorative cover, hang the bottom shell and then press it down (not direct vertical installation).

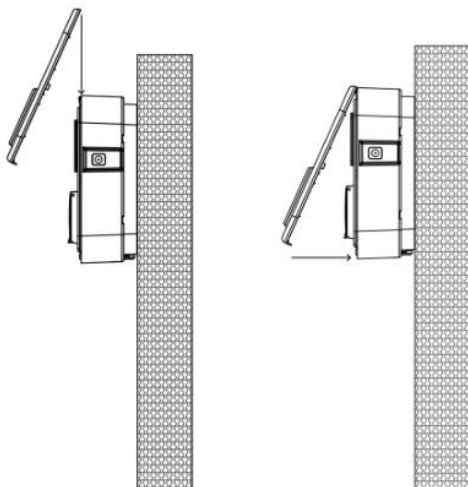

Fig. 5-12 Installation of decorative cover

- **Step 9: After hanging the decorative cover, press and lock the last screw[D].**

After the decorative cover is installed, install the last screw[D]

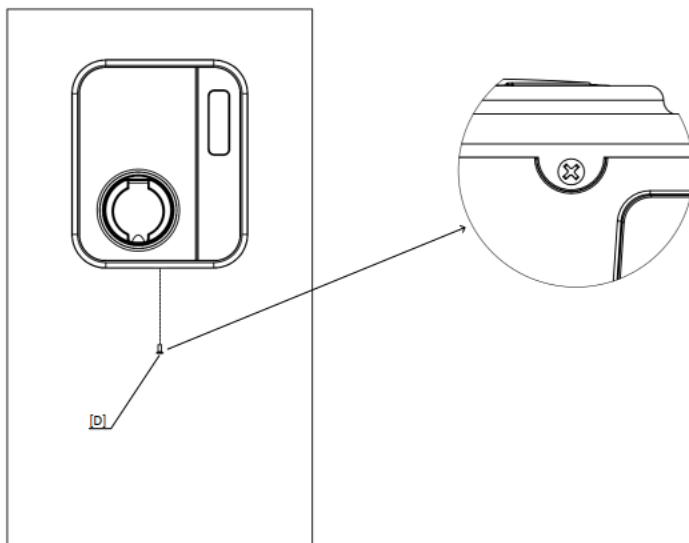

Fig. 5-13 Installation of screw[D]

5.5. Empty socket

Only offer for INJET ECO Plug & Cable Version series product.

INJET ECO AC EV charging station config a type 2 charging connector. When the charging station is in standby state, please plug the charging connector in the empty connector socket in order to protect the charging connector. Please use expansion screws to fix this empty socket at a suitable position beside the charging station.

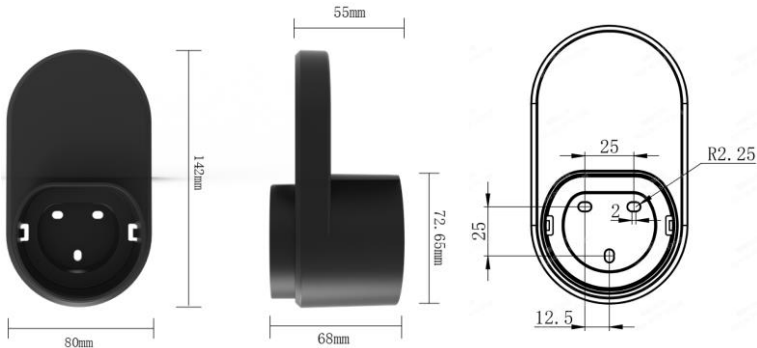

Fig. 5-14 Empty socket

5.6. Installation of 4G charging station (Optional)

If you have purchased the 4G version of the charging station, insert the 4G NANO SIM card into the SIM card slot before mounting it on the wall, the steps as follows:

- a) Use tools to remove the screws on the panel of the charging station, slowly open the panel of the charging post, be careful not to disconnect the cable connecting the panel and internal circuit boards

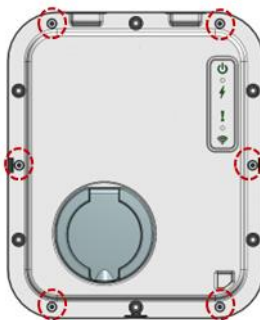

Fig. 5-15 panel of the charging station

- b) Find the communication PCBA, as shown in the following figure, insert the 4G card into the SIM card socket

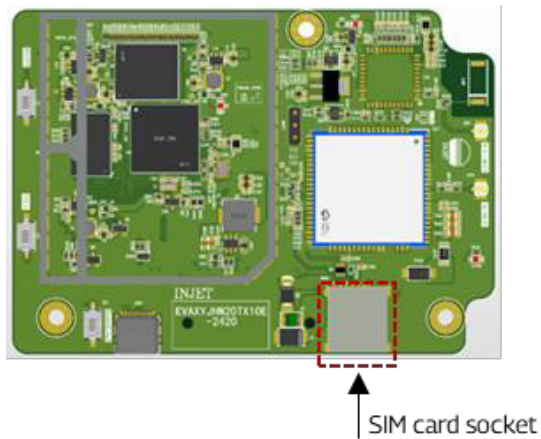

Fig. 5-16 PCBA

- c) Close the charging station panel and reinstall the removed screws.

6. OPERATION

6.1. Power on

After the INJET ECO device has been installed and confirmed in position, activate the power supply. The indicator light will illuminate, and upon hearing a 3-second buzzer activation, the charging station will enter standby state.

6.2. Human-Machine Interface

6.2.1. Overview

As shown in Fig. 6-1, INJET ECO is configured with multiple human-machine interfaces.

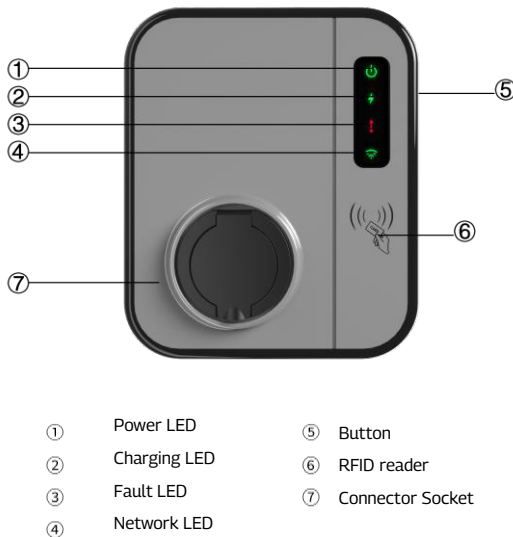

Fig. 6-1 HMI of INJET ECO

6.2.2. LED indicators

No.	LED indicator	Connotation
1	Power (Green)	On: Power on to normal standby /Standby status
		constant slow twinkle: Empty NFC and Empty M1 Card Setting mode
2	Charging (Green)	On: Charging completed
		Off: No charging cable plugged in.
		Fast twinkle: Plug in charging cable
3	Fault (Red)	0.5s on, 0.5s off continuous alternation: charging state
		Off: No fault
		Continuous twinkle: Ground fault
		Slow twinkle & Fast twinkle & 3s off: Slow twinkle count * 5 + fast twinkle count * 1 = Error code
4	Network (Green)	Off: not connected to the network
		On: Network connected and data exchanged
		Slow twinkle: Network connected, no data exchange
		Fast twinkle: Configure WiFi network status

6.2.3. RFID reader

In general, INJET ECO is equipped with RFID card reader as standard, and the charging process can be started and stopped by using the RFID card (shown as Fig. 6-2) configured with the host.

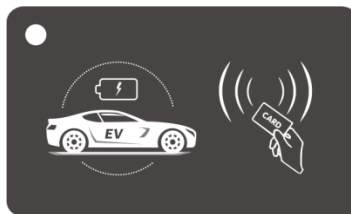

Fig. 6-2 RFID card

Empty NFC and Empty RFID Card Setting Steps:

- a) Users need to put the administrator card close to the swipe area, the charging post will beep once when it detects the administrator card.
- b) Hold the swipe action for 5 seconds and wait until the power indicator keeps flashing to enter the administrator setting mode.
- c) The administrator setting mode can last for 1 minute, put the empty NFC card or empty RFID card close to the card reading area to start the data setting.
- d) Buzzer 5 short beeps, power indicator returns to normal light, indicating successful card making.

***Note:** if the users want to use the NFC function, the users should make sure their phones have this function. then open the NFC setting interface on phone, choose the card making mode. Then bring the mobile phone close to the card swiping area and wait for the card making to be completed

6.2.4. Charging control button

You can press the button to control charging, when INJET ECO work in button-controlled mode.

- Start charging: plug the charging connector into EV socket, press button to start charging.
- Stop charging: press button again will end the charging, when EV is in charging.

6.3. Start Charging

- a) Park your EV into place, turn off, and put the EV under braking.
- b) Pick off the charging connector form empty socket of EV charging station.
- c) As shown in Fig.6-3, plug the charging connector into the AC charging socket of the EV.



Fig. 6-3 Plug into EV socket

- e) For the charging control mode of "Plug-and-play", the charging process will start automatically after plug in.
- f) For the charging control mode of "Button-controlled", press the button after EV connector plug in, the charging will start automatically.
- g) For the charging control mode of "Card-controlled", you can control charging process by swipe RFID card after charging connector plug in.

- h) For the charging control mode of "APP-controlled", If you are equipped with Bluetooth, you can control charging process by using APP after charging connector plug in.



- If you want to scan QR code on the side of charging station to start charging, please download and install the **WE E-Charge APP** on your smart phone.



WE E-Charge

- For Android phone, search **WE E-Charge** in Google Play or scan the QR code on the right to install APP.



- For iPhone, search **WE E-Charge** in APP Store or scan the QR code on the right to install APP.



- The user manual of APP please refer to the FAQ of APP.

6.4. Normally stop charging

- a) The charging station will automatically stop when the electric vehicle is fully charged.
- b) For the charging control mode of "Plug-and-play" charging station, you can manually stop charging as follow: press the unlock button of the remote key of the EV, the vehicle will stop charging (requires the support of the EV); if the charging does not stop, you may try to unplug the charging connector directly.
- c) For the charging control mode of "Button-controlled", you can stop charging by press button again, when EV is in charging.
- d) For the charging control mode of "Card-controlled", you can stop charging by swipe your RFID card again, when EV is in charging.
- e) For the charging control mode of "App-controlled", you can stop charging by APP, when EV is in charging.
- f) When the charging is end, please unplug the charging connector and plug back to the empty socket of charging station.

6.5. Abnormally stop charging

- a) Forced fault stop: A fault stops initiated by the onboard charging station of vehicle.
- b) Automatic fault stop: A fault stops initiated by the charging station.

6.6. Configure parameters

Taking the configuration of charging station parameters by mobile phone as an example, it is introduced as follows (the method of setting parameters by laptop is similar and will not be repeated):

■ Connect the WiFi hotspot

Restart the charging station, then turn on your phone or laptop's Wi-Fi function;

Find the charging station's hotspot with name "EVSE-XXXXXXX" (XXXXXXX means the last 8 SN number, and connect it, don't need a password.)

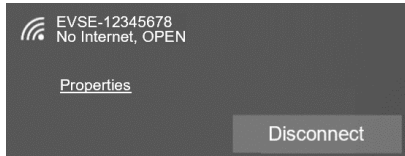

■ Log in to setting

Open your phone or laptop's browser and fill the website "192.168.4.1", you can access the Login Web Interface shown in Fig. 6-4. Enter the correct login password to enter the main menu interface. The login password is the last eight characters of the serial number.

About how to find the default login password:

Method 1:

Check the QR code sticker on the side of the device, the default password is the last 8 characters of the second line of the QR code. For example, the password is the 8 characters in the red box: '72f79d77'



Method 2:

Find the Wi-Fi hotspot name of the charging station, the default password is the last 8 characters of the hotspot name. For example, if the Wi-Fi name is EVSE-72f79d77, the password is 72f79d77.

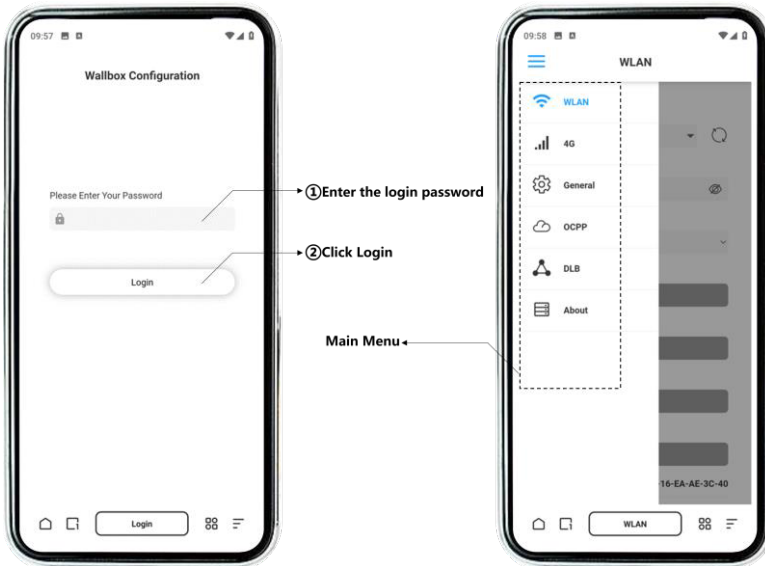

Fig. 6-4 Login Web & Main Menu Interfaces

■ **WLAN Settings Interface**

Click WLAN to enter the network setting interface, select the Wi-Fi you want to connect or click "Add Network" to input the Wi-Fi name, click Save after inputting.

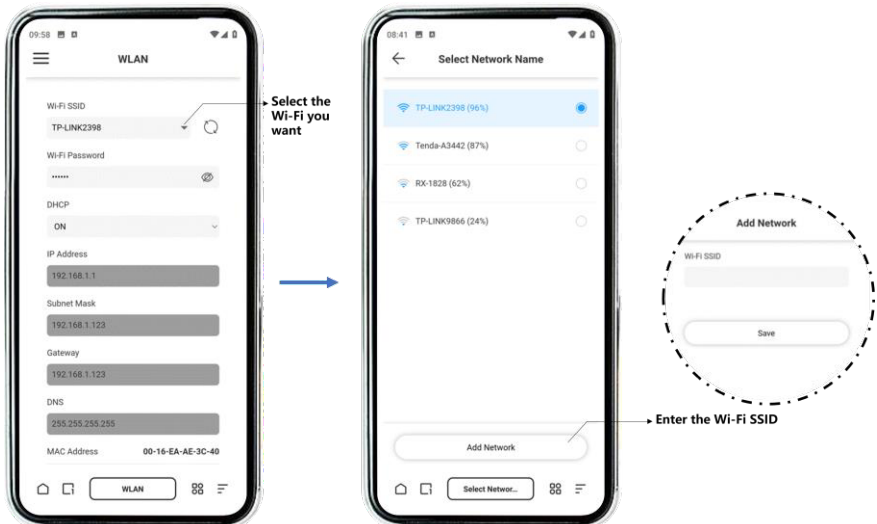

Fig. 6-5 WLAN Setting Interface

■ **4G/OCPP/About Setting Interfaces**

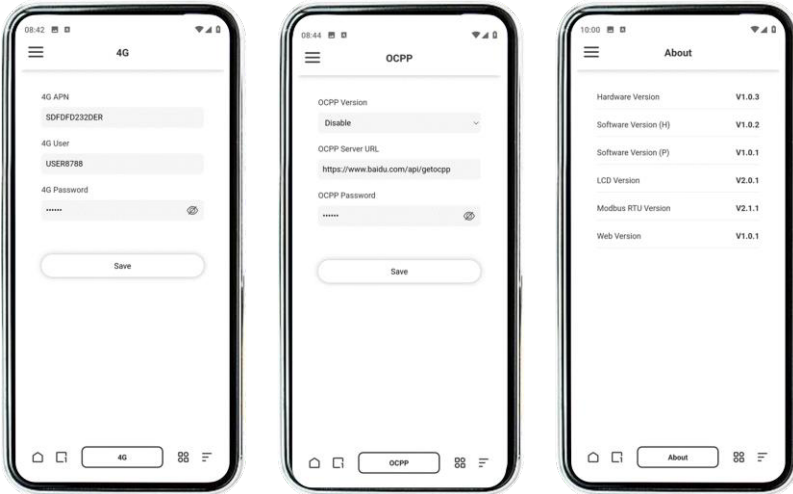

Fig. 6-6 4G/OCPP/About Setting Interfaces

■ **General Setting Interface**

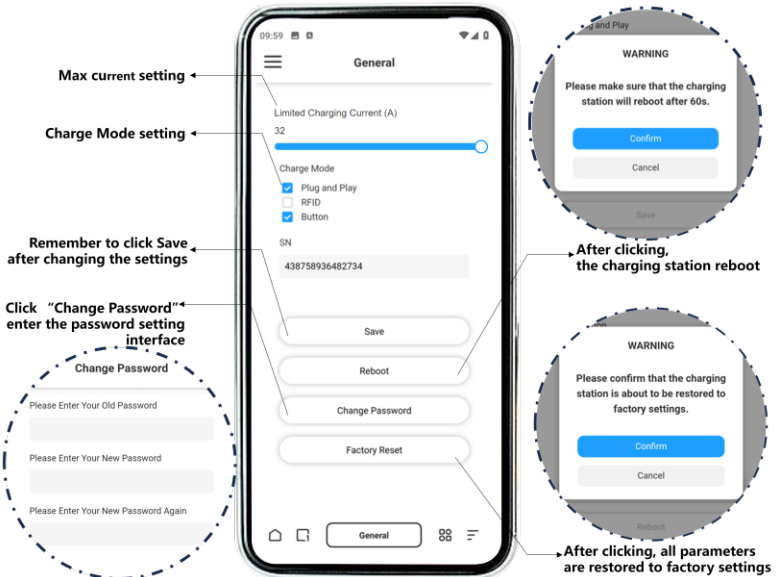

Fig. 6-7 General Setting Interface

■ **DLB Setting Interface**

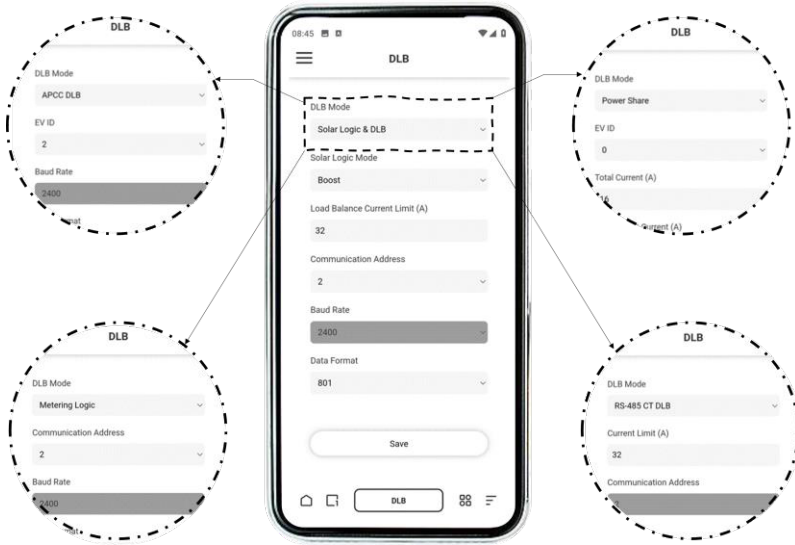

Fig. 6-8 DLB Setting Interface

7. FAULT HANDLING AND MAINTENANCE

7.1. Fault Handling

The charging station is automatically protected in the event of the fault. The fault information and handling methods are as follows.

LED indicator Flash information	Fault code	Handling method
<ul style="list-style-type: none"> ● Slow twinkle×2 	<p>Fault code 10: Wiring Fault</p>	<ul style="list-style-type: none"> ● Reconnect the wiring according to the labels and contact the after-sale staff to resolve the fault.
<ul style="list-style-type: none"> ● Slow twinkle×2 ● Fast twinkle×1 	<p>Fault code 11: CP voltage anomaly</p>	<ul style="list-style-type: none"> ● Check the connection of charging connector and EV socket. ● Disconnect and reconnect the charging connector.
<ul style="list-style-type: none"> ● Slow twinkle×2 ● Fast twinkle×4 	<p>Fault code 14: Overvoltage protection</p>	<ul style="list-style-type: none"> ● Check whether the input cable is connected correctly. ● Check whether the input voltage is abnormal.

LED indicator Flash information	Fault code	Handling method
<ul style="list-style-type: none"> ● Slow twinkle×3 	Fault code 15: Over-temperature protection	<ul style="list-style-type: none"> ● Check whether the charging station is covered or installed in a high temperature environment.
<ul style="list-style-type: none"> ● Slow twinkle×3 ● Fast twinkle×1 	Fault code 16: Electrical meter fault	<ul style="list-style-type: none"> ● Power off and restart the device.
<ul style="list-style-type: none"> ● Slow twinkle×3 ● Fast twinkle×2 	Fault code 17: Leakage protection	<ul style="list-style-type: none"> ● Check whether the charging connector and its cable are damaged or wet. ● Recover after pulling out the adapter.
<ul style="list-style-type: none"> ● Slow twinkle×3 ● Fast twinkle×3 	Fault code 18: Output shortage	<ul style="list-style-type: none"> ● Check whether the charging adapter and its cables are damaged or wet.
<ul style="list-style-type: none"> ● Slow twinkle×3 ● Fast twinkle×4 	Fault code 19: Output overcurrent	<ul style="list-style-type: none"> ● Check whether the charging connector is correctly connected. ● Check whether the OBC is normal. ● Check the set of output current.
<ul style="list-style-type: none"> ● Slow twinkle×4 ● Fast twinkle×3 	Fault code 23: Relay sticking	<ul style="list-style-type: none"> ● The device is damaged and needs to be returned to the factory for repair.
<ul style="list-style-type: none"> ● Slow twinkle×4 ● Fast twinkle×4 	Fault code 24: RCD fault	<ul style="list-style-type: none"> ● The RCD is damaged and needs to be returned to the factory for repair.
<ul style="list-style-type: none"> ● Fast twinkle 	Fault code 25: Ground fault	<ul style="list-style-type: none"> ● Charging station is not grounded; input power cable needs to be checked.
<ul style="list-style-type: none"> ● Slow twinkle×5 ● Fast twinkle×1 	Fault code 26: PEN fault	<ul style="list-style-type: none"> ● The ground cable has leakage current, and the charging station needs to be restarted
<ul style="list-style-type: none"> ● Slow twinkle×5 ● Fast twinkle×2 	Fault code 27: Anti-tampering protection	<ul style="list-style-type: none"> ● Check whether the charging station casing is tightly covered
<ul style="list-style-type: none"> ● Slow twinkle×5 ● Fast twinkle×3 	Fault code 28: Surge protection device	<ul style="list-style-type: none"> ● Damaged surge protection, please contact the after-sales staff
<ul style="list-style-type: none"> ● Slow twinkle×6 	Fault code 30: Neutral Wire and Live wire reverse fault	<ul style="list-style-type: none"> ● Check that the neutral and live wires are not reversed

LED indicator Flash information	Fault code	Handling method
<ul style="list-style-type: none"> ● Slow twinkle×6 ● Fast twinkle×2 	Fault code 32: Relay Fault	<ul style="list-style-type: none"> ● The device is damaged and needs to be returned to the factory for repair.
<ul style="list-style-type: none"> ● Slow twinkle×8 ● Fast twinkle×1 	Fault code 41: Under voltage protection	<ul style="list-style-type: none"> ● Check whether the input cable is connected correctly. ● Check whether the input voltage is abnormal.
<ul style="list-style-type: none"> ● Slow twinkle×8 ● Fast twinkle×2 	Fault code 42: Over-temperature current limiting protection	<ul style="list-style-type: none"> ● Stop charging and wait for cooling before using again.

7.2. Maintenance

To ensure the long-term stable operation of the equipment, please maintain the equipment regularly (usually every season) according to the operating environment.

- Check whether the equipment is well grounded and safe.
- Check whether there are potential safety hazards around the charging station, such as whether there are high temperature, corrosion or inflammable and explosive articles close to the charging station.
- Check whether the join point of the input terminal is in good contact and whether there is any abnormality. Check whether other terminal points are loose.

8. Appendix

8.1. OPTIONAL FUNCTIONS

INJET ECO supports realization of the Dynamic Load Balancing (DLB) function and power sharing function (between the charging stations), the following are several ways to realize it

- wiring external smart meters to achieve dynamic load balancing within the home by connecting to the PV system
- wiring with APCC module to realize dynamic load balancing and power sharing
- wiring with 485 CT Current Transformer to realize dynamic load balancing
- The charging stations are wired to each other via a 485-bus type to realize the power sharing

Since only one RS-485 interface is included, only one of the above functions can be selected.

8.1.1. Solar charging + Dynamic load balance via smart meter

- **Type1: 3-phase Energy Meter (SDM72D)**

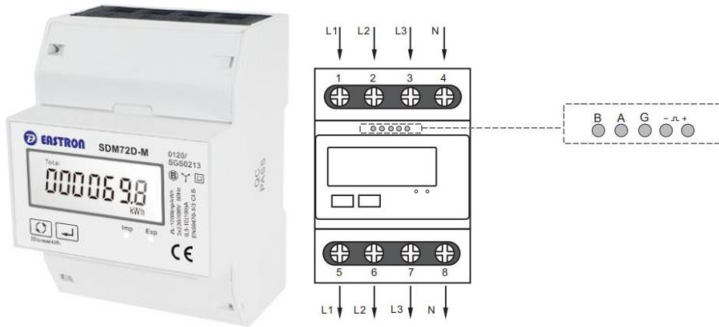

Fig. 8-1 3-phase Energy Meter

■ Wiring Methods

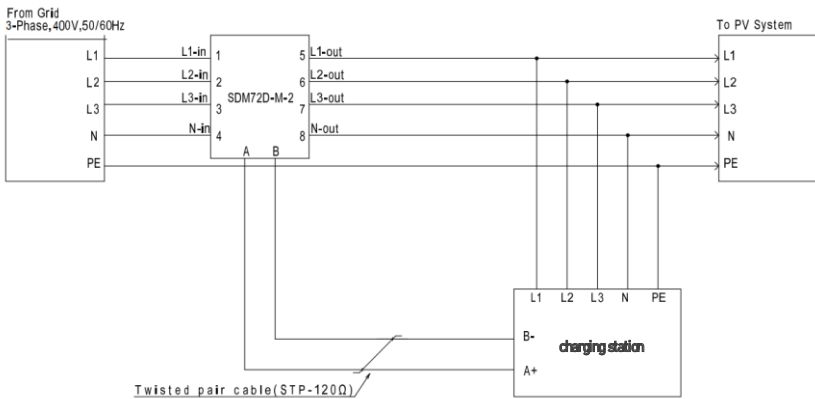

Fig. 8-2 Energy Wiring Method

■ Type2: 1-Phase Energy Meter (SMD230)

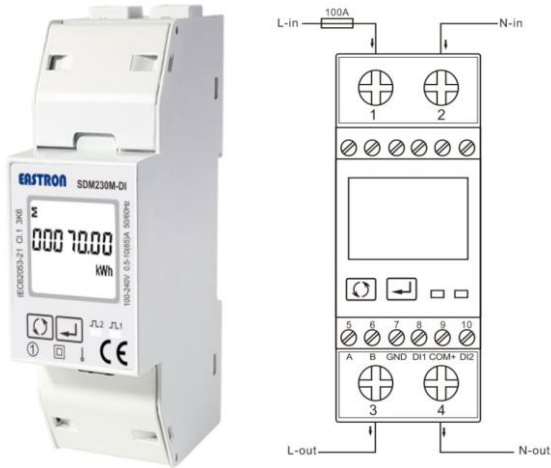

Fig. 8-3 1-phase Energy Meter

■ **Wiring Methods :**

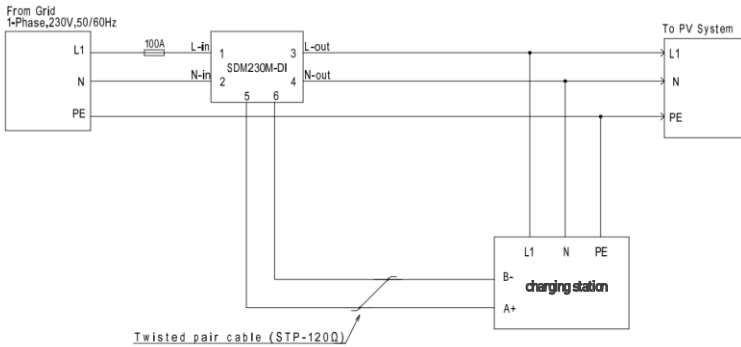

Fig. 8-4 Energy Wiring Method

■ **Operation**

a) **Set the Solar logic Charging mode and DLB Current limit**

Method :

- users need to log in the configuration page, select the DLB setting interface, select “solar logic & DLB” for the DLB mode, how to log in to the configuration page, please refer to chapter 6.6 of this manual
- set the relevant parameters by demand.
- or use WE E-Charge APP setting the solar charging mode. Connect INJET ECO charging station with the mobile phone through Bluetooth, and then scan the QR code on the side of the charging station with WE E-Charge APP to binding; In the "Settings" menu of WE E-Charge APP, you can set the parameters of solar charging

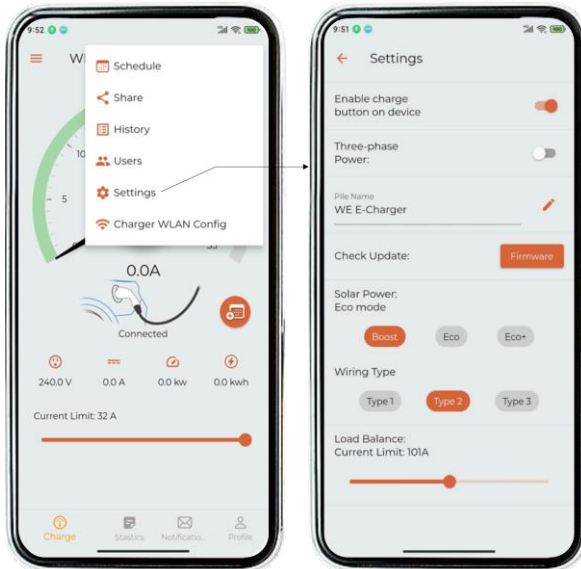
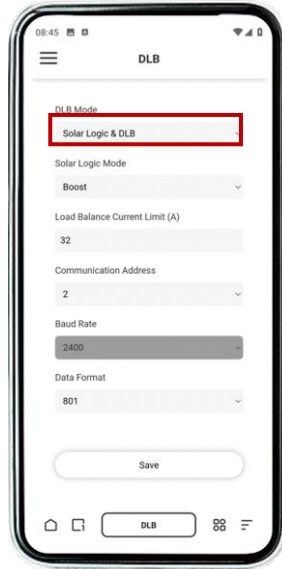

b) Charging mode of Solar logic



Mode	Description	Energy source
BOOST	Maximum charging power, the maximum charging current = the set current of charging station, the charging current is irrelevant to the output current of PV system.	Only Grid Or only PV system Or Grid + PV system
INJET ECO+	Most INJET economical charging, all charging energy comes from PV system. And if the grid-connected current of PV system < 6A, the charging will stop automatically.	Only PV system
INJET ECO	If the grid-connected current of PV system ≥ 6A, the charging current only comes from the PV system, and the charging current = grid-connected current of PV system.	Only PV system
	If the grid-connected current of PV system < 6A, the charging current = 6A. The charging current which cannot be provided by the PV system comes from the grid energy.	Grid + PV system

In INJET ECO+ Mode, all charging energy comes from the PV system. When the output current of the PV system is lower than 6A, INJET ECO will enter the state of suspended charging. As some EV models will enter the sleep state after stopping charging, it is necessary to disconnect the PP signal and reset the PP connection before waking up charging again. At present, because of INJET ECO cannot disconnect the PP signal automatically, the charging process may not be restarted again after the output is suspended in INJET ECO+ Mode.

8.1.2. Dynamic load balance via APCC

If the user is only equipped with the Dynamic load balance (DLB) function, it can be realized by the Charge-Mate (APCC) our company developed.

■ **Hardware list**

Parts	Picture	Quantity
Charge Mate (APCC)		1 pc
Split core CT (Current transformer)		1 pc for 1-phase charging station 3 pcs for 3-phase charging station

■ **System wiring diagram**

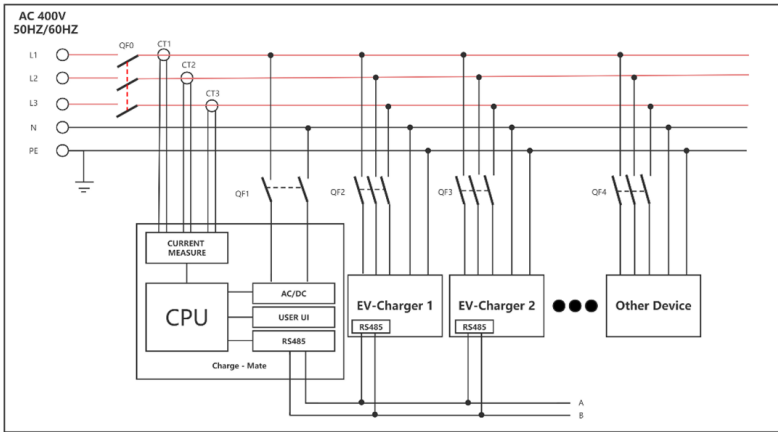

Fig. 8-5 System wiring diagram

According to Fig. 8-5, if it is a single-phase charging station, there are no CT2 and CT3. The input wires of charge mate only need to be connected to L1 and N.

■ **Operation**

Users need to log in the configuration page, select the DLB setting interface, select ‘APCC DLB’ for the DLB mode, and set the relevant parameters by demand.

a) **Total input current limitation setting**

Press the  button once, you can select the total input current limitation setting area as shown in Fig. 8-6.

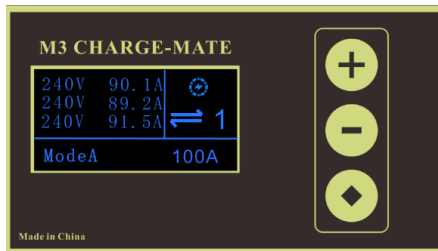



Fig. 8-6 Total input current limitation setting

You can set total input current limitation value in the range of 0- 200A through press button  or .

b) **Communication match function**

EV charging station needs to set the device address (1-5) through the offline webpage in advance. The default address of each EV-Charging station is 1. Each Charge-Mate can manage up to 5 charging stations. After the RS485 communication line is connected, Charge-Mate can quickly establish communication with the charging

station under normal conditions

c) Matching list

Press and hold buttons **+** and **-** simultaneously, the Charge-Mate will display the matching list of EV-Charging station's code number. Press the button **+** and **-** simultaneously, the Charge-Mate will be exiting the match List.

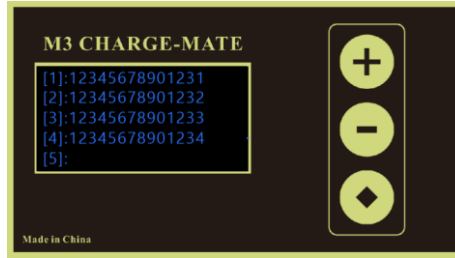

Fig. 8-7 Matching list

d) Restore factory setting

Press and hold buttons **+**, **-**, and **◆** simultaneously, the Charge-Mate will be restored to factory Settings and restarted.

8.1.3. Dynamic load balance via 485 CT Current Transformer

■ wiring

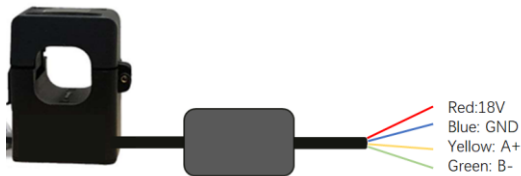

Note*: The 485 CT Current Transformer needs to be connected to a 9-24V DC power supply for proper operation, so when selecting this device, please prepare a DC power supply of the appropriate size.

■ Operation

After wiring, users need to log-in the configuration page, select the DLB setting interface, select "RS-485 CT DLB" for the DLB mode, and set the relevant parameters by demand. How to log in to the configuration page, please refer to chapter 6.6 of this manual.

8.1.4. Dynamic load balance via Power Sharing

■ 485 Bus Wiring

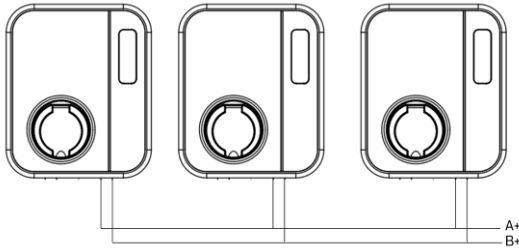

■ Operation

users need to log in the configuration page, select the DLB setting interface, select "Power Share" for the DLB mode.

About configuration setting, total control charging station need to choose "0", then set the maximum current. slave charging station need to choose "1-9", and set the maximum safety current, when the communication is abnormal, the charging station works within the maximum safety current to ensure the total power is within the set range. How to log in to the configuration page, please refer to the chapter 6.6 of this user manual.

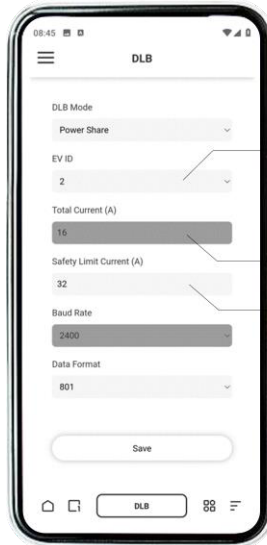

① total control charging station choose "0"
Slave charging station choose "1-9"

② total control charging station need
to set the maximum total current

③ Slave charging station need to set
maximum safety current

8.1.5. Meter logic

■ wiring

If the user only connects to the ordinary external meter to get the measure function, please connect the meter to the corresponding position.

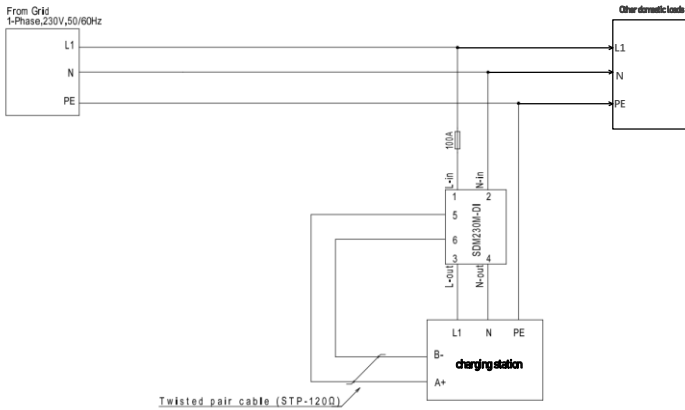

Fig. 8-8 1-Phase Meter

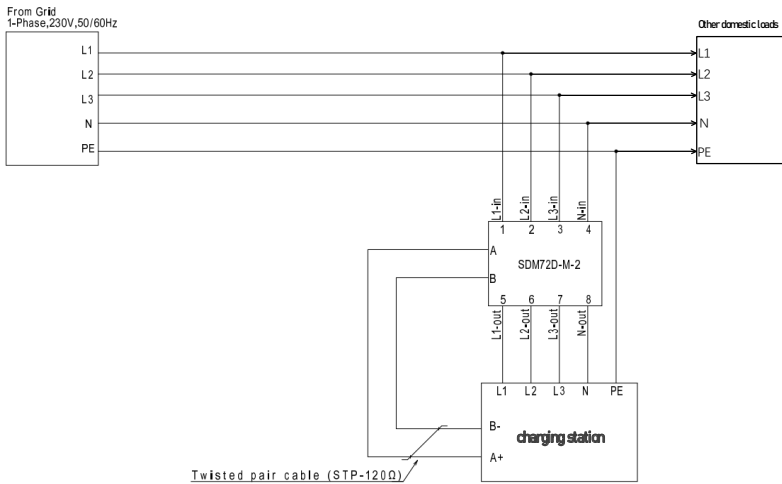
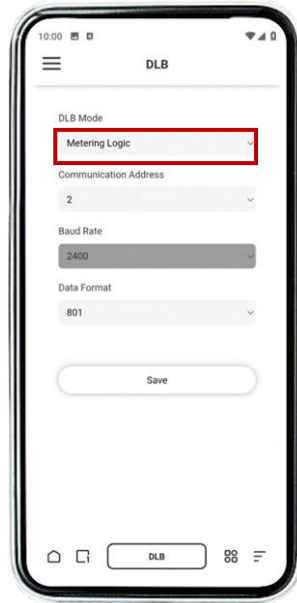

Fig. 8-9 3-Phase Meter

■ Operation

After wiring, log-in the configuration page, click on DLB setting interface, and select “Meter Logic” for the DLB Mode. How to log in to the configuration page, please refer to chapter 6.6 of this manual.



8.2. Pole Mounting Installation Guide

If users have purchased the pole series product, please refer to this section to mount the charging station on the pole.

■ Pole-mounting accessories (including A+B+C+D+E, shown as below)

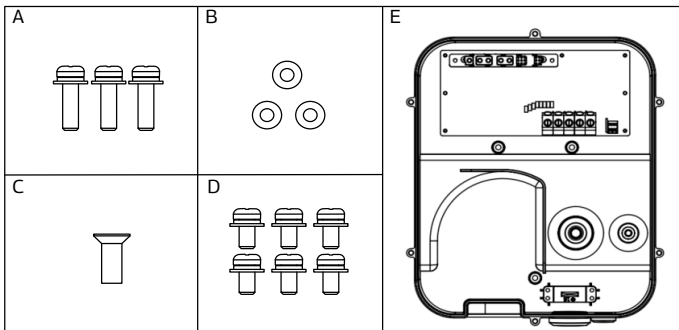

Note*: Parts of the pole-mounting accessories are in the accessory kit of the charging station product and the other parts are in the accessory kit of the pole product.

■ Installation steps:

① Secure the mounting attachment[E] to the pole according to the location of the holes

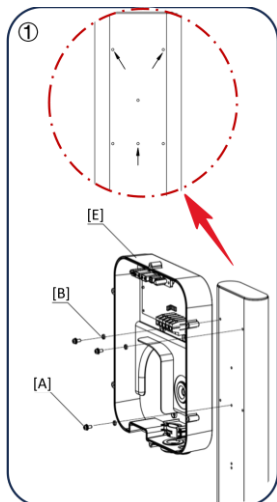

② After connecting the cable, hang the device on the mounting accessory[E]

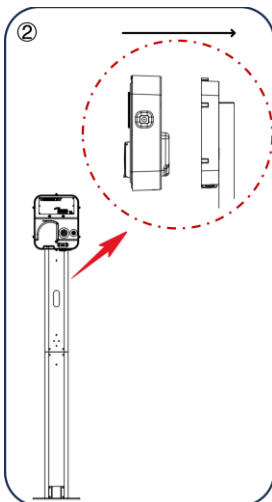

③ Rotate the security lock 90° to the right

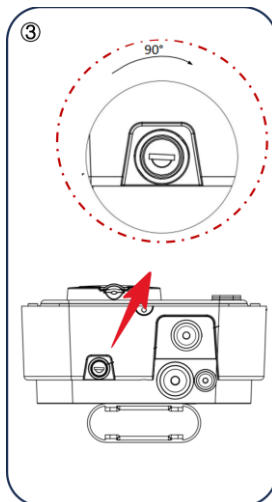

④ Install the six screws[D], as shown in the illustration

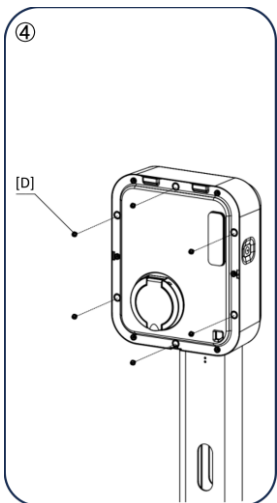

⑤ When installing the decorative cover, please note that there is a hook at the top of the decorative cover, hang the bottom shell and then press it down (not direct vertical installation).

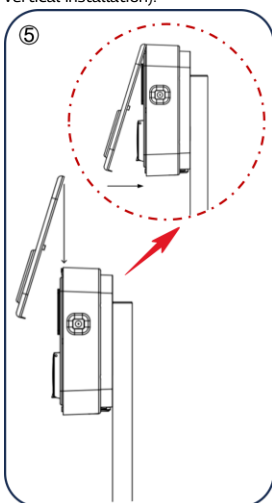

⑥ After the decorative cover is installed, install the last screw[C]

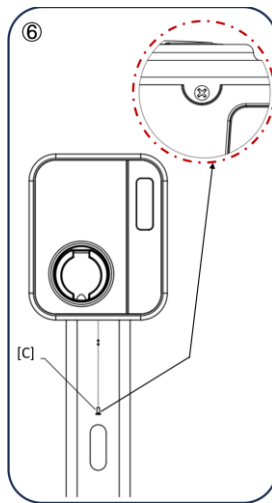

WARRANTY AGREEMENT

1. The scope of warranty refers to the product itself.
2. The warranty period is 3 years. During the warranty period, the company will repair the product free of charge in case of failure or damage (determined by the company's technical personnel) under normal use.
3. The starting time of warranty period is the date of product manufacture.
4. Even in the warranty period, a certain maintenance fee will be charged in case of the following situations.
 - ① Equipment failure caused by not following the user's manual
 - ② Equipment damage caused by fire, flood, abnormal voltage, etc.
 - ③ Equipment damage caused by using the product for abnormal functions.
 - ④ Equipment damage caused by foreign matter entering.
 - ⑤ Equipment damage caused by other human external factors.
5. The service fee shall be calculated according to the actual cost. If there is another contract, the contract shall prevail.
6. Please be sure to keep this card and show it to the maintenance personnel during the warranty period.
7. If you have any questions, please contact the agent or our company directly.

After sales service center

CONTACT INFORMATION

Dear Valued User,

Thank you for selected INJET products. It is always invigorating to realize that we are not alone in advancing a more sustainable future.

Should you have any inquiries while using INJET products, please do not hesitate to contact us using the information provided below, and we will respond to you promptly.

We sincerely appreciate your commitment to our shared planet by utilizing green energy for your travel needs.

INJET Overseas After-Sales Team

Email: evse.support@injet.com

Address: No.19 Tumenjiang Road, Deyang, Sichuan, China

COMPLIANCE STATEMENT OF WEEE

It is essential to separate electrical and electronic equipment (EEE) from other waste for proper recycling and disposal. It is vital that electrical and electronic equipment (EEE) is separated from other waste for proper recycling and disposal. We are WEEE registered and encourage you to do the same.

***Why should EEE be recycled separately from other waste?**

EEE often contains hazardous materials that can harm the environment if not properly disposed of. By mixing with general waste, these hazardous materials can seep into the soil and water, causing serious environmental damage.

****What can you do to ensure that EEE is properly disposed of?**

We encourage you to take your old EEE to WEEE recycling facilities near you. This ensures your device is treated responsibly, recovering valuable materials and preventing contamination. Your participation in this process helps protect the environment and promotes sustainable recycling practices.



DECLARATION OF CONFORMITY(DOC)

EU Regulatory Conformance

We (Sichuan Injet New Energy Co., Ltd.), hereby declare that this device is in compliance with the essential requirements and other relevant provisions of Radio Equipment Regulations 2017

Harmonized EN basic and engineering standards:

BS EN IEC 61851-1: 2019
BS EN IEC 61851-21-2: 2021
ETSI EN 301 489-1 V2.2.3
ETSI EN 301 489-3 V2.1.1
ETSI EN 301 489-17 V3.2.4
ETSI EN 300 328 V2.2.2
ETSI EN 300 330 V2.1.1
BS EN 61000-3-11: 2017
BS EN 61000-3-12: 2011
BS EN 50663: 2017
BS EN 62479: 2010
BS EN 50364: 2018

RF Exposure: This equipment complies with radiation exposure limits set forth for an uncontrolled environment.

UK
CA

**We provide customers
with all-round technical support.**



Any change without prior notice.