

Touchless exhaust extraction system

Stationary system for cars with all types of exhaust pipes



Easy to handle systems for all types of cars. Consists of a basic rail system which is completed with a touchless extraction unit. Very high extraction efficiency. One extraction unit can serve several work bays. Extraction units are easy to move, thanks to light-weight material and ball bearing wheels. Designed to minimize risk of damaging the car. Two units serve cars with twin exhaust pipes.

- **Touchless – no scraping**
- **Universal – for all types of exhaust pipes**
- **Versatile – for cars on the floor or lifted**
- **Ergonomic – easy to maneuver and move between workstations**
- **Practical – out of the way when not in use**

Product name	Touchless exhaust extraction system
Material	<p>Touchless extraction unit: Exhaust hood: EPDM Arm Ø100mm (4"): Aluminium Joints: Poly Amid Telescopic section: Aluminium Trolley: Glass-fibre composite 8 running wheels 4 guide wheels (all with sealed ball bearings) Resistant to all chemicals in diesel and petrol exhaust</p> <p>Rail 920: Rail profile: Aluminium, extruded, hardened, noncorrosive Sealing lips: EPDM rubber, profiled, with inner low-friction layer, delivered in coils according to track length End cover: Glass-fibre composite. Lid of galvanized sheet metal Brackets: Sheet metal, galvanized With 100 mm (4") threaded rods for alignment</p>
Material recycling (%)	100
Operating Temperature	Temperature resistance: Continuous 302°F (150 °C) Intermittent 356°F (180 °C)
Further technical data	Crosssection area: 36 in ² (230 cm ²)



Touchless exhaust extraction system

Description	Weight (lbs)	Model
Telescopic exhaust system, including trolley	Complete extraction unit, 37 kg (81 lbs) Rail incl sealing lips, 6.7 kg/m (5 lb/ft)	20808064
Telescopic exhaust system without trolley	Complete extraction unit, 81 lbs (37 kg) Rail incl sealing lips, 5 lb/ft (6.7 kg/m)	20808164

Touchless exhaust extraction system

Accessory		Part No
	Exhaust rail 920 L= 2.5 m (8')	20916020*
	Exhaust rail 920 L= 5.0 m (17')	20916120*
	Exhaust rail 920 L= 7.5 m (25')	20916220*
	Exhaust rail 920 L= 10.0 m (33')	20916320*
	Exhaust rail 920 L= 12.5 m (41')	20916420*
	Exhaust rail 920 L= 15.0 m (50')	20916520*
	Exhaust rail 920 L= 32.5m (106')	20918220*
	Exhaust rail 920 L= 35.0 m (115')	20917220*
	Exhaust rail 920 L= 40.0 m (132')	20917320*
	Exhaust rail 920 L= 45.0 m (148')	20917420*
	Exhaust rail 920 L= 50.0 m (165')	20917520*
	Top outlet Ø200 (8 in) for 920	20374246

*Complete with suspension parts, joint connectors, rubber seals, end covers and end stops.

Touchless exhaust extraction system

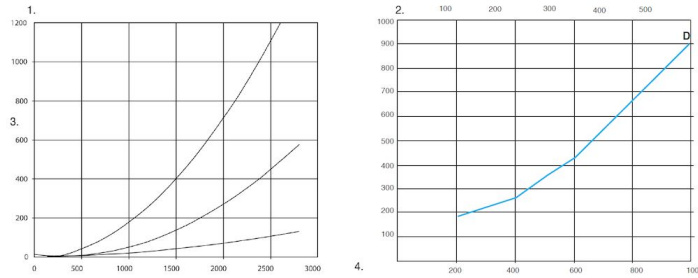

1: Rail 920 pressure drop, 2: Pressure drop Telescope including trolley, 3: Pressure drop Pa, 4: Airflow m3/h

A= Top connection, Ø200 mm, B= Side connection, Ø160 mm, C= Rail 920, per metre, D= Touchless extraction including trolley

Pressure drop approximately 55% less than corresponding system with hose.

Airflow recommendations Car: 600 m³/h (350 cfm)

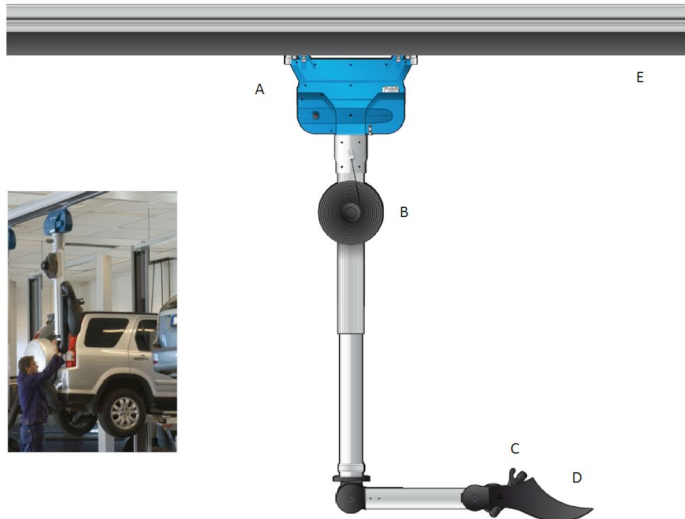

System parts

A = Automatic damper integrated in trolley 1500, closes when unit is in parking position

B = Balancer, Makes the Telescopic tube weightless when adjusting length of the Telescope

C = Joint release button For easy and secure positioning

D = Exhaust hood

E = Rail 920

Touchless exhaust extraction system

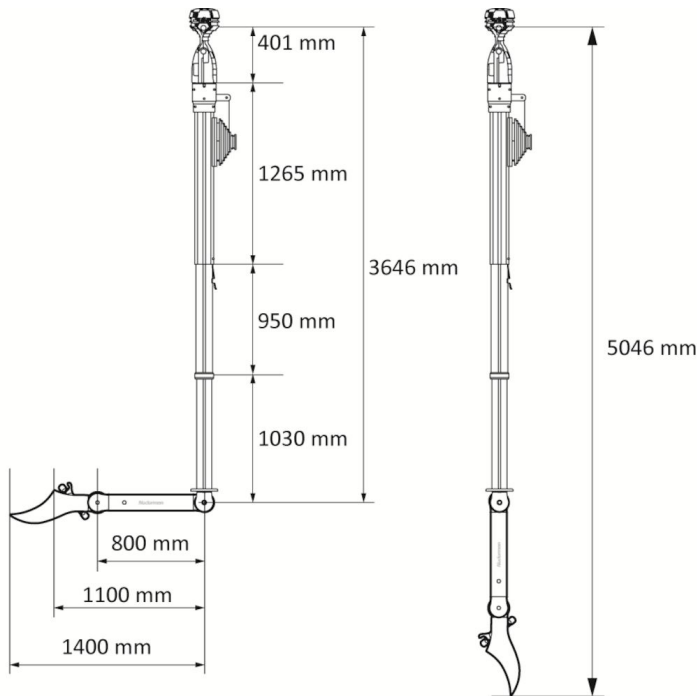
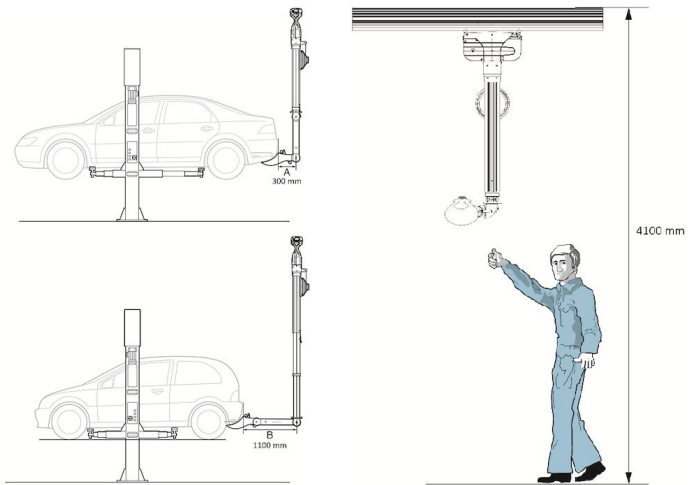

A = 300mm (The distance from the center of the rail to the back end of the longest car to be used)
B = 1100mm (The distance from the center of the rail to the back end of the shortest car to be used)