

MACHINE SPEC SHEET

R-2536C: Automatic Reclaim Machines

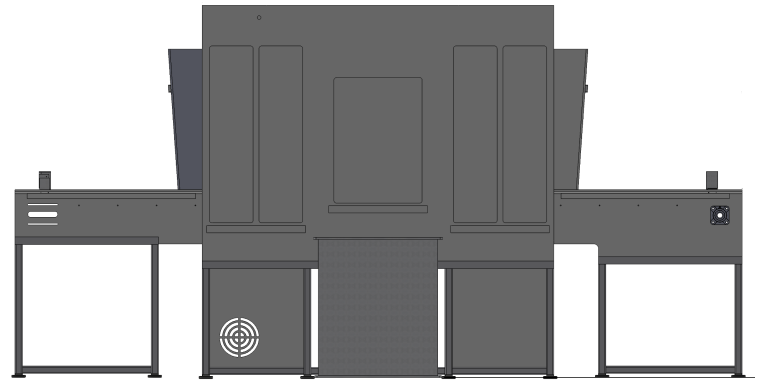
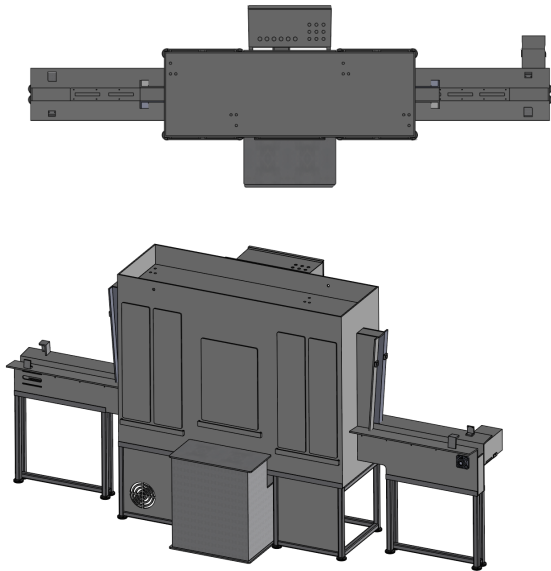

Customer Info	
Company Name	
Customer Name	
Email Address	
Phone Number	
Shipping Address	
Shipping Address	
City	
State	
Zip Code	

Machine Specs	
Infeed Length	<input type="checkbox"/> 36.0" (Included)
Outfeed Length	<input type="checkbox"/> 36.0" (Included)
Air @ 6,9 (100PSI)	8cfm @ 100psi
Electrical	<input type="checkbox"/> 208/230V, 3ph, 24A, 50/60Hz <input type="checkbox"/> 208/230V, 1ph, 44A, 50/60Hz
Water	1 x 1" NPT Standard Fitting
Drain	3/4" or 1 1/4" NPT Utility Pump
Screens Per Hour	13 Per Hour
Machine Direction	<input type="checkbox"/> Left to Right <input type="checkbox"/> Right to Left
*Crate dimensions/ shipping weight	146" x 48" x 87" 1600 Lbs

*Will vary depending on extras (chemical, tanks) ordered

Use:

Bluewater integrates essential capabilities into a unified, automated process for efficient screen cleaning. Our screen cleaning machines utilize advanced technology to reclaim screens from start to finish. These innovative designs not only minimize human error but also lower workplace risks and reduce labor costs.

Manufacturers Notes:

- Installed by Bluewater Technician
- Backed by 24 month parts warranty
- Made and Manufactured in the USA

Body Length	71"
Body Standard Width	24.0"
Body Width with Recirc	36.0"
Body Height	75.0"
Machine Length (min)	12' 3"