



South Dakota 4-H

Dog Project Guide

Review and Revision: 4-H Dog Coordinating Council

Original Publication: 2022 – Kasee Hieb | former SDSU Extension State 4-H Agri-Workforce Coordinator



**SOUTH DAKOTA STATE
UNIVERSITY EXTENSION**



Table of Contents

Section 1 – Dog Agility	1-3
What is Agility?	1-4
Purpose of Agility	1-4
Rules	1-4
Class Description/Requirements	1-6
On-leash Class	1-6
Off-leash Class	1-6
Advanced	1-7
Excellent	1-7
Obstacle Performance Requirements	1-8
Scoring	1-8
Obstacle and Jump Specifications	1-10
Section 2 – Dog Obedience	2-13
Competition Purpose	2-14
Chapter 1: General Guidelines	2-14
Chapter 2: Guidelines for Performance and Judging	2-15
Chapter 3: Basic	2-19
Chapter 4: Pre-Novice	2-21
Chapter 5: Novice	2-24
Chapter 6: Graduate Novice	2-27
Chapter 7: Open	2-30
Chapter 8: Graduate Open	2-33
Chapter 9: Utility	2-37
Chapter 10: Brace	2-40
Chapter 11: Team	2-41
Glossary of Terms	2-42
Jump Construction	2-43

Section 3 – Dog Rally	3-45
Introduction	3-46
General Rules	3-46
Classes and Advancements	3-48
Guidelines for Judges	3-49
Guidelines for Stewards	3-50
Rally Signs and Descriptions	3-52
Section 4 – Dog Showmanship	4-60
Purpose of Showmanship	4-61
Showmanship Competition	4-61
Competition Rules	4-61
Gaiting Patterns	4-65
4-H'ers Handling Skills	4-68
Judging the Competition	4-69
Proper Breed Presentation	4-69
Showmanship Knowledge Questions	4-69

Photo credits:

A-Frame: Jessica Kuldane; Dog Walk: Kristine Loland; See Saw: Rising Sun High Voltage, Stephanie Malone, owner; Pause Table: Mojave Schnauzers, Las Vegas, NM; Pipe Tunnel: Bel-rose Bridgette of Sandwynn, CD RE OAJ AX, Sandwynn Corgis & Ellis Dog Training; Weave Poles: Sweetbay Newfoundlands; Bar Jumps: Winwood's Blazing Star, Winwood Farm; Panel Jump: © M. Plonsky (photo used with permission); Tire Jump: Smokey Valley's Neko; Broad Jump: GCh Ashbrook Put Me In, Coach RE AX AXJ NF, Tracey Deyette; Kountry Lover Sydney, Kountry Silky Terriers; Jackey Photography, Beardstown, KY; TBR English Springer Spaniels; Anna Kigilyuk, alfa-german-shepherds.com; of Jimmie Robinson, danehaven.com; Nestle Purina Body Condition System (used with permission).

What's new for 2024

Bordetella Vaccine Required – Dogs who participate at 4-H events need to have the Bordetella vaccine, in addition to the Rabies and DHLPP vaccines.

Affidavit – Families are no longer required to upload a separate dog affidavit as in years past. Instead, families must update their dog information in 4-H Online and upload a proof of vaccination from your veterinarian that shows current Bordetella, Rabies and DHLPP vaccines.

Regional Dog Championship Participation – If a 4-H member would like to participate in more than one regional championship, they are able to. They would be eligible for ribbons and awards at each regional show (change from 2023).

Veteran Jumps – For dogs 7 years old and older, jumps will be one height lower than their measured jump height for jumps in any class.

Rally Signs – Rally signs have been updated to reflect American Kennel Club rally signs. Therefore some sign numbers have been changed and added from previous years.

Age of Dogs - Dogs must be fully vaccinated to participate in dog practices. Dogs must be 6 months old or older for any 4-H show. Additional age requirements are noted in the Agility section.

Number of Dogs - Each exhibitor can register an unlimited number of dogs in 4-H Online. However, they may only show one dog per sport.

Use of Bait – In both novice and open showmanship classes, baiting will be allowed.

If you have any questions about any of the changes, please feel free to reach out to the South Dakota 4-H Dog Coordinators Wendy Sweeter (wsweeter@lincolncountysd.org) or Nathan Skadsen (nathan.skadsen@sdstate.edu).

2024 Regional Dog Championship Schedule

July 20, 2024 – Southeast Regional Dog Championship, Lennox, SD

August 17, 2024 – Central Regional Dog Championship, Mitchell, SD

September 28, 2024 – Western Regional Dog Championship, Rapid City SD

Event schedules and registration deadlines will be announced later this spring.

Section 1

Dog Agility

Dog Agility

What is agility?

Patterned after equestrian show jumping, dog agility combines the elements of a dog's agility, briskness and confidence with a handler's control over an obstacle course designed for dogs. It is a fun sport with great spectator appeal.

Purpose of agility

- Enhance the working relationship between the dog and handler.
- Build confidence in both dog and handler.
- Provide positive motivational training methods and interactions with the dog.
- Improve conditioning of dog and handler.
- Promote good sportsmanship and citizenship.
- Promote a better-rounded handler/dog team.
- Add new members and maintain established members in the dog project.

Rules

Dogs can get seriously hurt performing agility, thus all attempts should be made to provide a safe environment for dog and handler. Because the safety of both dogs and 4-H'ers is of paramount importance, the following rules will be enforced.

1. Dogs participating in the agility program must have had one year of obedience training or participated in one year of county level 4-H dog obedience prior to participation.
2. Dogs must be a minimum of 12 months old to begin agility training. It is recommended that larger breeds be at least 18 months old. This is because the growth plates in the bones are still developing until the average age of fourteen months and even later for larger breeds.
3. No dogs with a physical or mental condition that would significantly impair their performance may participate. Examples include but are not limited to hip dysplasia, disc problems, severely slipped stifles, shoulder problems, three-legged dogs or being overweight. A dog of advancing age that is sound may be able to compete.
 - Members are strongly encouraged to consult his/her veterinarian before beginning agility training. The dog's weight/body condition is a consideration for judging soundness. Overweight or obese dogs are at increased risk of injury.
4. Female dogs in season are not permitted to compete at any level (county, regional or state). If a dog comes into season during county achievement days, arrangements can be made to show at another county when the female dog is not in season.
5. Intact male dogs will be run at the end of their respective class (last) at the state show.
6. Any dog that attempts to bite or attack a human or another dog will immediately be removed from the activity or event. Dogs excused from the show will not receive a ribbon placing. If the incident occurred at the county show, the dog will therefore be ineligible to qualify and compete at the state dog show. Please see page 5-80 for the complete Aggressive Dog Policy.
7. In order to advance to the next higher-class level, a score of 10 faults/points or less must be earned in a competitive setting (county, regional, or state 4-H show, or a United States Dog Agility Association (USDAA), American Kennel Club (AKC) or North American Dog Agility Council (NADAC) trial). A dog/handler team receiving 10 faults/points or less at a state competition must advance to the next level the following year. A scored run during a demonstration or class will not count. If the dog/handler team is able to advance, they must be able to perform all required obstacles in the next level before competing in a county, regional or state 4-H show.
8. The use of a completely fenced area is encouraged (but not required). The minimum ring size is at least a double obedience ring. A 100 feet x 100 feet or 80 feet by 120 feet (or larger) arena is strongly recommended. This allows for adequate spacing of obstacles, providing a safer course for the dog and handler to run. At the higher levels, this helps to

ensure an adequate distance between the entrance of adjacent obstacles preventing unnecessary obstacle choices for the dog. It also allows for the setting of safe obstacle approaches, especially for the contact obstacles (straight on versus an angled approach). A smaller ring size necessitates tight turns and close placement of obstacles which increases the risk of injury and potentially creates inappropriate advanced handling/discrimination moves that even the Excellent level dogs and handlers may not be prepared for.

If the ring size at a county or state show is smaller than recommended the judge will have the authority to reduce the required number of obstacles and/or change the course pattern to provide a safer or more appropriate course for the dogs and handlers. Upon agreeing to judge a county achievement day, the judge should request an equipment list in order to design courses. If a county does not have the required equipment for a given level, it cannot be offered at that county achievement days. Affected youth may make provisions to show at another county achievement days, IF the dog has been trained to perform that obstacle (for example: teeter or dog walk).

9. Training or trialing for agility on straight concrete or other smooth flooring is considered unsafe for both dogs and handlers. Mats or some other form of textured floor covering that will not slip are strongly recommended to be used to provide traction for both the dog and handler. This also provides cushioning for the dog when jumping, thus helping to protect the dog's joints. If held inside, county or state shows must have some form of textured flooring to provide traction and cushioning such as mats, carpeting or artificial turf.
10. All courses must have a clearly designated start and finish. All obstacles must be sequentially numbered using cones or some other movable system. Obstacles on the course should be spaced approximately 18 feet apart. In no case shall obstacles be spaced any closer than 12 feet apart. Start and finish line areas should be kept clear for the dogs competing. Placement of check-in, scoring tables and an area for dogs waiting to run, etc. should be considered when setting up the agility area.
11. A three-minute group walk through without dogs will be allowed prior to the class at all county and state shows. At the state show, a practice jump and weave poles may be available if space safely allows. These are for use just prior to the class they are competing in, not by other teams for practice and/or training.
12. Judges will inspect all equipment prior to the beginning of the show and may modify the requirements to the extent necessary to eliminate any piece of unsafe equipment, or if an outdoor trial, weather conditions make performance of an obstacle unsafe.
13. All agility jumps must be of the type that have a displaceable bar or plank. Jumps made from PVC pipe are recommended for safety reasons, in case a dog inadvertently jumps into the standard. (The dog will usually knock the entire PVC jump over, versus wood standards which may not give, resulting in injury.) PVC jumps are also less expensive to make than wood.
14. The collar must be a plain, flat well-fitting buckle or quick/clip release collar with no tags or other attachments. Training collars, choke, pinch or electronic collars, head halters and fancy collars are not permitted. In On-Leash and Off-Leash classes a collar is required; it is optional for Advanced and Excellent classes.
15. Handlers may not jump over the obstacles with their dogs.
16. Handlers may not touch their dogs or an obstacle while running the course.
17. Poor sportsmanship will not be tolerated. Any handler swearing, yelling at their dog, using excessive corrections, rough handling of dogs or loud complaints about exhibitors or the judge, etc., will be disqualified.
18. During the On-Leash class, the leash must be held at all times except when the dog is going through a tunnel or chute. After each tunnel, the leash must be picked up before the next obstacle is executed. A 6-foot leash is recommended. The handler is encouraged to regain control of his/her dog before continuing to the next obstacle after retrieving the leash.
19. The judge will penalize any handler receiving outside assistance. In severe cases, the handler will receive a white ribbon. The show committee is responsible for investigating any incidents of outside assistance reported to them. See standard faults in the scoring section for more information.
20. A dog unable to complete the course for any reason,

including leaving the ring, ceasing to work for a significant period of time as defined by the judge, being out of control, etc., will receive a white ribbon.

21. Any dog refusing an obstacle for the third time will be asked by the judge to go on to the next obstacle; anyone not obeying the judge's order will be disqualified.
22. Handlers may use voice commands, signals or both. Handlers are encouraged to talk or cheer their dogs through the course. No treats or toys will be allowed on the course. A handler is allowed to have treats and/or a toy just outside the starting area while waiting for his/her turn to run. There is no penalty for multiple commands or verbal encouragement, but all must be in the spirit of good sportsmanship.
23. Any dog fouling the ring during a competitive run will receive a white ribbon. Do not attempt to move the dog if they have started to urinate or defecate (so it stays in one place!). Vinegar, or some other odor-neutralizing substitute, must be available to clean fouled equipment. Fouled equipment may be removed from the course at the judge's discretion, and all dogs running the course previously may, at the judge's discretion, be required to re-run the course. If time allows, the eliminated handler and dog may be allowed to run at the end of his/her class for experience, however no scoring or ribbon will be awarded for this type of run.
24. Jump heights are based on the dog's height at the top of the shoulders. A dog should be measured by a project leader when beginning agility, so that the dog and handler practice jumping at the correct jump height. A dog found to have jumped at a lower than required height may be asked by the judge to rerun the course at the correct height.

Dog's Height	Height of Jump
Under 10 inches (in.)	4 in.
10-14 in.	8 in.
14-20 in.	12 in.
Over 20 in.	16 in.

New for 2024 – Veteran Jumps For dogs 7 years and older, jumps will be one height lower than their measured jump height.

Class Description/Requirements

All dogs must enter and exit the ring on leash.

To facilitate judging and decrease waiting times for competitors, the A-frame height will be 4 feet 6 inches

for both the On- and Off-Leash classes. It is also recommended the judge use the same course for both the On- and Off-Leash classes. This will allow more flexibility in the run order and ease some of the pressures on both competitors and show organizers (e.g., managing the long sits and downs). Because the On- and Off-Leash groups are typically the biggest classes, using the same course will allow the judge to alternate between On- and Off-leash groups, providing added flexibility for competitors. Because the main objective of the Off-Leash class is to focus and control the dog without a leash, running the same course as the On-Leash class will still present a significant challenge for the Off-Leash competitor.

On-Leash Class

The purpose of this class is to test the ability of a dog and handler to perform obstacles safely and correctly, testing the handler's ability to train a dog for beginning agility. The handler must demonstrate his/her control of the dog on leash around the agility obstacles. The main evaluation for this class is control and safe obstacle performance within the allotted time. Handlers should focus on safe obstacle performance and not on how quickly s/he can get around the course.

- The course shape is a simple S, M or U.
- Nine obstacles are approved for this class (no closed tunnel or chute due to safety concerns).
- These nine obstacles include:
 - A-frame (apex at 4 feet, 6 inches)
 - Pause table
 - Pipe tunnel
 - Six jumps
- No time fault penalty in On-Leash; standard course time is 60 seconds.

Off-Leash Class

The purpose of this class is to test the partnership between dog and handler and evaluate focus and control off leash. The dog will have learned obstacle performance in the On-Leash class and now must demonstrate safe obstacle performance off leash. This presents a whole 'new' picture to the dog and handler making it acceptable to run the same course as the On-Leash class.

- After positioning the dog at the start line, the handler will remove the leash and place it on the ground.
- The course shape is a simple S, M or U.
- Nine obstacles are approved for this class: (no closed tunnel or chute due to safety concerns)
 - A-frame (apex at 4 feet, 6 inches)
 - Pause table
 - Pipe tunnel

- Six jumps
- The standard course time is 60 seconds.
- All dogs must be shown off leash with a collar.
- A dog with a leg toward a United States Dog Agility Association (USDAA) or the North American Dog Agility Council (NADAC), United Kennel Club (UKC) or and American Kennel Club (AKC)-novice agility title is ineligible, as is a handler having earned a USDAA Junior Handler Program (UJHP) Elementary certificate.
- Members may show at this level until achieving a round of 10 fault/points or less at a state level competition then must advance to the next level the following year.

Even if the handler and dog are able to advance, before competing in a county, regional or state show, the handler and dog must be able to safely and correctly perform all obstacles required for the next higher level. If a handler and dog enter a show and clearly do not know how to perform an obstacle or the handler states the dog has not performed the obstacle, they will be excused from the ring and not allowed to run to avoid possible injury to the dog.

Project leaders should not enter dogs at the next higher level, if the handler or dog is not ready, because doing so could hurt the team's confidence, or risk injury to the dog by performing agility above its experience level.

Advanced

The purpose of this class is to further test the focus and control of the dog in the off-leash setting. It is expected that the handler will demonstrate more confidence and control with his/her dog than in the lower levels. New obstacles allow the assessment of the handler's continued ability to teach his/her dog agility obstacles.

The course shape is slightly more challenging than a simple figure eight. A pipe tunnel may be placed underneath the A-frame to facilitate the formation of a figure eight.

- After positioning the dog at the start line, the handler will remove the leash.
- Twelve to 14 obstacles are approved for this class: (no closed tunnel or chute due to safety concerns)
 - A-frame (apex 5 feet)
 - Pause table
 - Pipe tunnel
 - Dog walk (middle section elevation of 3 feet for 8-foot lengths or 4 feet for 12-foot lengths)
 - Tire jump
 - Long jump

- Four to six jumps
- The standard course time is 75 seconds.
- All dogs must be shown off leash with a collar.
- Dogs with a qualifying score toward a UKC title, a NADAC or USDAA regular title, or a qualifying towards an AKC-open agility title are ineligible, as is a handler having earned a UJJP Intermediate certificate.
- Members may show at this level until achieving a round of 10 fault/points or less at a state level competition then must advance to the next level the following year.

Even if the handler and dog are able to advance, before competing anywhere, the handler and dog must be able to safely and correctly perform all obstacles required for the next higher level. If a handler and dog enter a show and clearly do not know how to perform an obstacle or the handler states the dog has not performed the obstacle, they will be excused from the ring and not allowed to run to avoid possible injury to the dog. Project leaders should not enter dogs at the next higher level, if the handler or dog is not ready, because doing so could hurt the team's confidence, or risk injury to the dog by performing agility above its experience level.

Excellent

The purpose of this class is for the handler to demonstrate advanced handling and training skills. More focus and control are expected, and the handler's training skills of obstacles are tested with the addition of more obstacles, including moving objects, such as the teeter. This is the highest level of 4-H agility; it is expected that these handlers will serve as mentors for beginning competitors.

- After positioning the dog at the start line, the handler will remove the leash.
- The course shape is slightly more challenging than a simple figure eight, with a pipe tunnel allowed under the A-frame.
- The judge is given flexibility in course design, as long as adequate distance between obstacles and the approaches is maintained.
- The following 13 to 15 obstacles are approved: (no closed tunnel or chute due to safety concerns)
 - A-frame (apex at 5 feet)
 - Pause table
 - Pipe tunnel (one to two depending on availability)
 - Dog walk (elevation 3 feet)
 - Tire jump
 - Long jump
 - Six weave poles
 - See saw

- Four to six jumps
- All dogs must be shown off leash with a collar.
- The standard course time will be computed at 2 yards per second, not to exceed 75 seconds.
- Dogs that have completed an Open title in AKC or a Starters/Novice title in USDAA or NADAC agility competition are ineligible for this class.
- Dogs that purple at state can continue to show at this level indefinitely.

Obstacle Performance Requirements

A-Frame – The dog must touch the safety (contact) zone with at least two paws while ascending the up ramp in the direction designated by the judge, cross over the apex and descend the down ramp, touching the safety (contact) zone with at least two paws before leaving the obstacle.

Pipe Tunnel – The dog must enter the opening to the tunnel in the direction designated by the judge and exit the other end of the tunnel.

Pause Table – The dog must jump onto the table and assume the down, sit or stand position for a period of five seconds. The judge will count the seconds out loud, commencing when the dog has fully assumed the down position. The count is, “5 and 4 and 3 and 2 and 1 and go.” If the dog leaves the table, or gets up before the five seconds are over, the handler will be instructed to move on. In the On- and Off-Leash Classes an interrupted count is restarted from the point it was interrupted. In the Advanced and Excellent levels, an interrupted count will be restarted from the beginning. Each tug on the leash to down the dog will be given a five-point penalty. After three attempts to down the dog by tugging on the leash, the handler must move on to the next obstacle and the team will be given a 20-point fault.

Jumps – The dog must jump over the obstacle in the direction designated by the judge, crossing between the two jump standards and over the bars or planks without knocking off the top bar or plank.

Dog Walk – The dog must touch the safety (contact) zone with at least two paws while ascending the ramp in the direction designated by the judge, traverse the cross plank, and descend the other ramp, touching the safety (contact) zone with at least two paws.

Tire Jump – The dog must jump through the tire in the direction designated by the judge. The dog may touch the tire with its feet.

Weave Pole – The dog must weave in and out in a continuous motion down the complete line of poles. The

dog begins by passing on the right side of the first pole (pole next to the dog's left shoulder), crossing the line of poles between pole number 1 and 2, then wrapping around the left side of pole number 2, then crossing the line of poles between 2 and 3 and continuing in a sequence down the complete line of poles demonstrating a weaving motion. A handler/dog team must correct for any missed poles, and fully complete the weaving pattern. A HANDLER CAN NOT TOUCH THEIR DOG DURING THE PERFORMANCE OF THE WEAVE POLES.

The handler's hand may cross the plane of the weave poles, but s/he must not touch the dog. Handlers will be given three attempts at the weave poles; if not completed s/he must move on to the next obstacle and the team will be given a 20-point fault.



Long (or broad) Jump – The dog must jump over the planks without touching them; crossing between the front corner marker poles in the direction designated by the judge, clear the span of the planks and exit between the back-corner marker poles.

Teeter or Seesaw – The dog must touch the safety (contact) zone with at least two paws while ascending the seesaw, cross the plank's pivot point, causing the seesaw to tilt to the ground on the other end, and descend the remainder of the plank, touching the safety (contact) zone with at least two paws before leaving the plank. The plank shall touch the ground prior to the dog leaving the plank. The dog must be in control of the plank. A performance deemed unsafe will be given a 20-point fault. The judge has the authority to automatically have the handler and dog redo the teeter if, in the judge's opinion, the unsafe performance could significantly impact future performances. No additional points will be given; however, the time will continue.

Scoring

Standard Faults – charged at 5 points

- Wrong Course – Taking an obstacle in the wrong order or going the wrong direction over an obstacle (including back-weaving three or more weave poles). All four paws of the dog must be committed to an obstacle to be charged with this.
- On and off the table – Charged for the first occurrence only.
- Knocking a bar off a jump. – Applies whether it was the dog, the handler or the leash that knocked the bar off.

- Touching the dog at any time during the course.
- Missed Contact Zone – Yellow Zone
- Dog steps on or walks over the long jump.
- Tugging on the leash – Five faults per occurrence, to elimination if it is severe or constant.
- Outside help or interference – Someone telling the handler which obstacle is next, any commands or cues to the dog, etc., five faults up to elimination, depending on the severity.
- Handler touching any obstacle.
- Handler jumps over the jump with the dog – Per each occurrence.
- Dog goes in the wrong direction between the tire and the frame.
- Anticipation of the table count – Dog gets off before the judge finishes saying the word go.
- Failure to pick up the leash – After a tunnel and before the next obstacle is performed.

Major Faults – charged at 20 points

- Omitting any obstacle – Includes being told by the judge to omit the obstacle because of the two-paw safety rule. It also includes such things as the handler omitting an obstacle by choice or by error or crossing the finish line before the last obstacle is completed correctly.
- Three refusals of a single obstacle.
- Uncorrected or improper entry to weave poles.
- Bailing off A-frame, dogwalk or teeter after one attempt on the ascent, middle or descent. The team will receive a major fault and move on.
- Failure to correct on the pause table – Dog who jumps off before the beginning of the word go; forcing or holding the dog in any position on the pause table.

Automatic white ribbon:

- Eliminating in the ring.
- Constant tugging on the leash or dog out of control.
- Dog who stops working or leaves the ring may not complete the course.
- An extreme amount of outside help.
- An excessive amount of touching the obstacles or the dog.

Disqualification (No Ribbon Awarded):

- Poor sportsmanship – including, but not limited to swearing, treating a dog harshly, complaining loudly about judges or other exhibitors, using treats in the ring, failure to omit and go on to the next obstacle when instructed to do so by the judge.
- Abuse of dogs anywhere on the show grounds.
- Dog attacks or threatens to attack a human or another dog.
- Use of treats or toys in the ring.

Time Faults:

- Each class level has a specified time limit within which the course must be completed (standard course time).
- The timer will time each performance to .01 of a second.
- Any time beyond allotted time is considered a time fault and will be penalized on a 1 fault per one-second basis (or fraction).
- No bonus points are added for completing the course faster than required; thus, in all classes, handlers should focus on correct obstacle performance which is where faults can occur instead of running the course as fast as possible.

Final Score:

- Course faults and time faults are added together and subtracted from an overall score of 200 points.

Score	Ribbon
190-200	Purple
180-189	Blue
170-179	Red
169 or less	White

Obstacle and Jump Specifications

The following specifications will apply to all obstacles. When no tolerance or range is given for a dimension, a tolerance of 4.0% is implied. Tolerances do not apply when a range is specified.



A-Frame: The A-Frame is constructed from two panels, the top surface of which is constructed from wood or a wood-like substance. The panels are 35 to 49 inches wide, and their lengths are both within

2 inches of either 8 feet or 9 feet. Panels shall be of a consistent width and connected so as to eliminate gaps large enough to fit a dog's foot or toe. The height of the A-Frame is 54 inches when 8-foot panels are used and 60 inches when 9-foot panels are used, both with a one-inch tolerance. The top surface is painted and has a rough, non-slip surface. (Alternating layers of sand and flat, latex paints are recommended.) Slats are placed across the width of the panels to provide footing. They are $\frac{3}{8}$ to $\frac{3}{4}$ inch thick and $\frac{3}{4}$ inch to 2 inches wide, and they extend within $\frac{1}{4}$ inch of the panel sides. Slat edges shall be rounded or beveled; a $\frac{1}{4}$ inch radius is recommended. The centers of the slats are spaced at 12-inch intervals with a 2-inch tolerance, and no slat is within 4 inches of the top or a contact zone. Contact zones are painted on the lower 42 inches of both panels with a $\frac{1}{4}$ -inch tolerance. The color of the zones contrasts with the rest of the panel, but it may not be white, black or brown. Bright yellow contact zones are recommended.

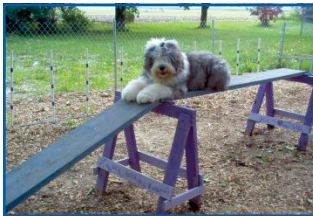

Dog Walk: The dog walk consists of a center section and two ramp sections. The surfaces of which are made from wood or a wood-like substance. All sections are 12 inches wide, plus or

minus an inch, and all are either 8 feet long or 12 feet long. Planks shall be connected so as to eliminate gaps large enough to fit a dog's foot or toe. Within a 2-inch tolerance, the top of the center section is 36 inches above the ground when using 8-foot sections and 48 inches when using 12-foot sections. The top surfaces of all sections are painted and have rough, non-slip surfaces. (Alternating layers of sand and flat, latex paints is recommended.) Slats that conform to those described for the A-Frame are placed across the width of the ramp sections to provide footing. Contact zones are painted on the lower 42 inches of both ramps with a $\frac{1}{4}$ -inch tolerance, using the color specifications described for the A-Frame.



Seesaw: The seesaw consists of a plank (or panel) supported near the center by a base that acts as a fulcrum. The plank is 12 inches wide with a 1-inch tolerance, and 12 feet long. The base extends

at least 2 inches past the sides of the plank so the dogs can see the pivot point. The plank is balanced so that it hits the ground in less than three seconds when a 3-pound weight is placed 12 inches from the raised end. The height of the seesaw measured to the top of the board at the pivot is 24 inches, plus or minus 2 inches. The top surface of the plank is painted and has a rough, non-slip surface. (Alternating layers of sand and flat, latex paint is recommended.) Slats that conform to those described for the dog walk are optional. Contact zones, 42 inches long are painted on each end of the plank with a zero-inch tolerance, using the color specification described for the A-Frame.



Pause Table: The top of the pause table is 36 inches square, plus or minus 2 inches, with a non-slip surface (carpeting may be used but remember that it will make the table much

heavier to carry.) The vertical edge of the top of the table top must be 3 inches or greater in height and it is recommended that the table edge be of a color in contrast to the running surface and ring gating. The height of the table (within 1 inch) is 8 inches for dogs in the 8-inch and 12-inch divisions, and 16 inches for dog in the 16-inch and above division.



Pipe Tunnel: The open tunnel is a flexible tube of durable material that is capable of being formed into curved shapes. The two openings are either round or approximately rectangular,

with a height and width of 24 inches plus or minus 2 inches. Its length is 10 to 20 feet long and it is secured in position to prevent a dog from moving it. No portion of a tunnel holder that is underneath the tunnel shall be more than $\frac{1}{2}$ inch thick. Tunnel supports used between the

beginning and end of the tunnel shall not have rigid uprights such as steel or wood, that are capable of fitting between the ribs and projecting into the tunnel. It is recommended that sand bags or the largest containers of kitty litter be used as tunnel supports. They can be connected across the top by bungee cords or straps.



Weave Poles: The weave poles consist of six poles that are either stuck in the ground or mounted in a base. (The base design is recommended.) The poles are 1 to 1 ¼ inches in diameter and at least 36 inches high

and uniformly spaced at intervals of 24 inches. The weave poles must flex at the base so as to accommodate larger dogs. It is recommended that if a rigid support is used at the base of each weave pole it does not exceed 4 inches in total height as measured from the ground to the top of the rigid support. (It is required that stripes be taped or painted on the poles to make them more visible to the dogs.) If a base is used, it may be no thicker than one inch and no wider than four inches, and it must be supported so as not to interfere with a dog's performance.



Bar Jumps: Bar jumps consist of displaceable bars supported by bar supports that are mounted to uprights. The supports must be positioned so that the tops of the bars can be set

within ¼ inch of the four different jump heights (4 inches-8 inches-12 inches-16 inches). An additional position for a bar placed 2 to 6 inches above the ground is also recommended. For a 4-inch jump, two bars can be crossed in an X using the 8-inch cups. The judge shall determine bar placement. The bars must be either cylindrical with a diameter between 1 ¼ and 1 ¾ inches, or square with sides measuring between 1 ¼ and 1 ¾ inches. Bars must be constructed from wood or plastic (PVC jumps are recommended because of increased safety). They must be 4 to 5 feet long and striped for visibility. The bar must sit on top of its support so that the bar is easily displaced. If rectangular bars are used, the top of the support must be flat and no wider than the bar it is supporting. If cylindrical bars are used, the supports may be no wider than the bar, and they should have a lip that is no more than ⅛ inch higher than the support, although lips up to ¼ inch are allowed. Bolts used as bar supports are allowed if they comply with all other

provisions of the section and if bars can be made displaceable from both directions. Bars held in place by Velcro™, magnets, etc. are not allowed. The inside of the uprights must be at least 32 inches tall, and the upright must be 1 to 4 inches wide. (An inside height of 42 inches and a minimum width of 32 inches are recommended for visibility. Widths less than 30 inches are recommended to facilitate handler movement on the course.)



Panel Jumps: The panel jump uses up to six cross-boards to give the illusion of a solid wall from the jump height to the ground.

Specifications for the board supports and uprights are the same as for the bar jump. The cross-boards are 4 to 5 feet long, 3 to 4 inches wide and no thicker than 1 inch. The top board for all jump height classes shall be a maximum of 4 inches high. Panels supports are to be placed 1 ¼ inches to 1 ¾ inches below the top of the board so as to be easily displaced.



Tire (circle) Jump: The tire jump, sometimes called the circle jump, consists of a tire (or a circular object that resembles a tire) suspended from a rectangular frame. The inner diameter of the tire is 24 inches, plus or minus an inch, and the wall is 3 to 8 inches thick. There must be at least 8

inches between the outside of the tire and the sides of the frame, and the frame must be tall enough to accommodate the tire's four different jump heights, as specified for the bar jump. The uprights of the frame shall be secured to the base and the base weighted or secured properly to the running surface so as to discourage tipping. The jump height is measured from the ground to the bottom of the tire opening.



Broad Jump: The broad jump is composed of either four 8-inch sections or five 6-inch sections, and four corner markers. The actual width of the 8-inch sections is 7 to 8 inches and the width of the 6-inch sections

is 5 to 7 inches. The sections are constructed from a top piece and two sidepieces. The length of the sections is between 4 and 5 feet long, and they may be of different

lengths. To improve visibility, either the center of the sections or both ends must be marked with a color-contrasting band that is at least 3-inches wide. The sections are of varying height, and they may be arranged in either ascending order or as a hogback. (The ascending AKC obedience broad jump is recommended.)

When an ascending arrangement is used, each section is at least ½ inch higher than the previous one, and the height of the front edge of a section is at least ½ inch lower than the back edge. No portion of a section may be lower than 1 inch or higher than 6 inches. In a hogback arrangement, the sections ascend in height halfway across the jump and then descend. The ascending sections are at least ½ inch higher than the previous one, and the height of the front edge of a section is at least ½ inch higher than the back edge of the next. The descending sections are at least ½ inch lower than the previous one, and the height of the front edge of a section is at least ½ inch higher than the back edge. When an odd number of sections are used, the front edge of the middle section may not be higher than the back edge. No portion of a section may be lower than 1 inch or higher than 10 inches.

The length of the jump for both the ascending and the hogback configurations is twice the jump height of that division. Consequently, not all the sections are used in the lower height divisions. In those cases, the jump must be assembled with the lowest sections. The length of the jump (within 1 inch) and the number of sections to be used for the different divisions are listed below. The corner markers are at least 1 inch wide and 36 inches high, and they may be decorated to improve visibility. They are either attached to the sides of the first and the last sections, or they are freestanding and placed as close as possible to those positions. (Freestanding is recommended.)

Division	Length (in)	# of 6 in sections	# of 8 in sections
4 in	8	1	1
8 in	16	2	2
12 in	24	3	3
16 in	32	4	3

Section 2

Dog Obedience

Dog Obedience

Purpose

4-H Obedience Shows and Matches are guided by the principles of good sportsmanship, both in and out of the ring. The purpose of 4-H Obedience Shows and Matches is to demonstrate the usefulness of the dog as a companion of man, not merely the dog's ability to follow specified routines in the 4-H obedience ring. All 4-H members in a class are required to perform the same exercises in the same way so that the relative quality of the various performances may be evaluated. However, the primary objective of 4-H Obedience Shows and Matches is to help youth develop life skills, by teaching them how to work with dogs safely and effectively. The result of this process will be a 4-H member who can apply dog handling skills in the home, in public places and in the presence of other dogs, in a manner that will reflect credit on 4-H Dog Obedience.

The performances of the dog and the 4-H member in the ring must be accurate and correct, conforming to the requirements of these guidelines. However, it is also essential that the dog demonstrate willingness and enjoyment of its work, and that smoothness and naturalness on the part of the 4-H member be given precedence over a performance based on military precision and decisive commands.

Chapter 1: General Guidelines

Section 1. Dog Show and Match Rules

The 4-H Obedience Guidelines shall govern the conduct of and shall apply to all persons and dogs participating in 4-H shows and matches.

Section 2. Identification

No commercial advertising of any sort may be on clothing or the equipment in the show ring. The wearing of clothing with a 4-H emblem is encouraged. 4-H T-shirts, supplied by the Fair or from the counties, may be worn.

Section 3. Family Members

More than one 4-H member may show the same dog in the same year, in different classes.

Section 4. Dogs that May Not Be Shown

Dogs that have not been under the direct care and management of the 4-H member for a minimum of two months may not participate in 4-H Obedience Shows and

Matches. This does not mean that the dog must live with the 4-H member, only that the 4-H'er must be regularly responsible for its basic care.

Dogs in obvious pain from a previous illness or injury shall not be shown. Consideration of a dog's physical disability needs to be addressed between the handler and project leader before starting the project. A veterinarian's written approval is required if a dog's soundness is questioned.

Dogs in season may not be shown.

Any dog that attempts to bite or attack a human or another dog will immediately be removed from the activity or event. Dogs excused from the show will not receive a ribbon placing. If the incident occurred at the county show, the dog will therefore be ineligible to qualify and compete at the state dog show. Please see page 5-80 for the complete Aggressive Dog Policy.

Section 5. When Titles Are Won

When a 4-H dog has won an outside title (i.e. AKC), it may be shown in 4-H Obedience Trials. If the 4-H member won the title, that team must show at the equivalent 4-H show level. If someone else won the title, the 4-H member must show at the highest level appropriate for that team as determined by the 4-H member, parent, project leader and/or 4-H Advisor.

Level of showing determined by experience of handler

4-H	AKC
Basic	Beginner Novice
Pre-Novice	Novice
Novice	Novice
Graduate Novice	Graduate Novice
Open	Open
Graduate Open	Graduate Open
Utility	Utility

Once a dog and 4-H member have purpled at the state level (4-H), that team must advance to the next level. This option may be exercised at the county level if the team is unable to attend the State Fair. If a 4-H member starts over with a new dog, they may start at Basic B and progress accordingly.

Section 6. Risk

Any dog that attempts to bite or attack a human or another dog will immediately be removed from the activity or event. Dogs excused from the show will not receive a ribbon placing. If the incident occurred at the county show, the dog will therefore be ineligible to qualify and compete at the state dog show. Please see page 5-80 for the complete Aggressive Dog Policy.

Section 7. Disturbances

Any dog that attempts to bite or attack a human or another dog will immediately be removed from the activity or event. Dogs excused from the show will not receive a ribbon placing. If the incident occurred at the county show, the dog will therefore be ineligible to qualify and compete at the state dog show. Please see page 5-80 for the complete Aggressive Dog Policy.

Section 8. Decisions

At shows and matches the decisions of the Judge shall be final in all matters affecting the scoring and the working of the dogs and their handlers.

Section 9. Obedience Ribbons

South Dakota 4-H uses the Danish System for determining ribbon placings. The following point schedule will be used at the South Dakota State Fair. Counties may develop a less stringent point schedule and “curve” if needed.

Ribbon	Points
Purple	180-200
Blue	160-179
Red	140-159
White	139 and less

Section 10. Stewards

The Judge is in sole charge of his/her ring until his/her assignment is completed. Stewards are provided to assist him, but they may act only on the Judge’s instructions. Stewards shall not give information or instructions to handlers except as specifically instructed by the Judge, and then only in such a manner that it is clear that the instructions are those of the Judge.

Section 11. Ring Conditions

The ideal ring size is at least 40 feet wide and 50 feet long. The ideal surface or covering provides firm footing for the largest dogs. Rubber or similar non-slip material totaling at least 4 feet in width must be laid for the takeoff and landing at all jumps unless the surface, in the Judge’s opinion, is such as to not require it. At an outdoor show or trial the rings shall be about 40 feet wide and 50 feet long. The ground shall be clean and level, and the grass, if any, cut short.

The Judge’s table and chairs shall be of such size and location to cause no interference with the performance while in the ring.

Dogs are not allowed in the ring until they are shown.

Chapter 2: Guidelines for Performance and Judging

Section 1. Use of Leash

All dogs shall be kept on leash except when in the 4-H obedience ring or practice ring. Dogs must be brought into the ring and taken out of the ring on leash. Dogs may be kept on leash in the ring when brought in to receive awards, and when waiting in the ring before and after the Group exercises. When required, the leash shall be left on the Judge’s table or other designated place between the individual exercises and during all exercises except the Heel on Leash and Group exercises. The leash must be of fabric or leather and, at the Pre-Novice level or lower, must be at least 6 feet long. For Novice level and higher, the leash must be at least 4 feet long to provide adequate slack in the Heel on Leash exercise.

Section 2. Collars

Dogs in the 4-H obedience Basic and Pre-Novice rings are allowed to wear one approved training collar. These include slip/combo collars (martingale), choke collars (standard, show fur savers, nylon flat and American), Halti head collars, gentle leader collars (promise halters), German steel collars (sprenger, coastal and prong collars), harnesses and plain buckle collars.

Dogs in 4-H Novice and higher classes must wear well-fitting plain buckle, slip collars or choke collars. Slip collars of an appropriate single length of leather, fabric or chain with two rings, one on each end are acceptable. These are to be used only for training.

Collars must be well fitting. The collar length should not exceed the dog’s neck measurement plus 3 inches. Nothing shall be hanging from the collars (no tags). Electronic collars are not allowed in any instance.

If there is a medical reason for the use of a different collar, it must be noted on the health certificate. IF APPROVED EQUIPMENT IS NOT USED, THERE WILL AN AUTOMATIC RIBBON DEDUCTION IN THE RING.

Section 3. Heel Position

In these guidelines, the Heel position means that the dog shall be straight in line with the direction the handler is facing, at the handler’s left side, and as close as practical to the handler’s left leg without crowding, permitting the handler freedom of motion at all times. Ideally, the dog’s shoulder should be even with the handler’s left hip. This

shall be the definition whether the dog is sitting, standing, lying down or moving at heel.

Section 4. Hands

In all exercises, the arm positions shall be taken before any heeling is done.

In all exercises in which the dog is required to “heel on leash” one of the options below shall be followed:

- The right hand and arm must move naturally, while the left arm is bent and the left hand shall hold the leash against, and centered in front of the body, in the area of the waist.
- The right arm is bent, and the right hand holds the leash against, and centered in front of the body, in the area of the waist, while the left hand loosely guides the leash at the handler’s side.
- Both arms are bent to the waist and both hands hold the leash against, and centered in front of the body, in the area of the waist.

In all exercises in which the dog is required to “heel free” one of the options below shall be followed:

- The handler’s arms and hands shall move naturally at the handler’s sides while in motion, and shall hang naturally at the handler’s sides while not in motion
- The right hand and arm must move naturally, while the left arm is bent to the waist and the left hand shall be held against, and centered in the front of the body, in the area of the waist.

The left forearm shall be carried, as much as possible, against the body. In either of the above situations the hands and arms may be adjusted during the Fast portion of an exercise, in order to maintain balance. There shall be a substantial deduction if the hands and arms are not carried in one of the positions stated above.

In all exercises in which the dog is required to “come to” or “return to” the handler and “sit in front,” the handler’s arms and hands shall hang naturally at his/her sides while the dog is coming in and until the dog has sat in front. A deduction shall be made if a handler’s arms and hands are not hanging naturally at his/her sides while the dog is coming in and until the dog has sat in front.

Section 5. Commands and Signals

Whenever a command or signal is mentioned in these guidelines, the handler must give a single command (either a voice command and/or a hand signal). Any extra commands or signals must be penalized. When a command and/or signal is mentioned in the guidelines, the handler may give either a command, signal, or both a command and signal simultaneously (all levels). When a signal is permitted and given, it must be a single

gesture with one arm and hand only, and the arm must immediately be returned to a natural position. When a signal command *only* is used it cannot be preceded by the call name of the dog. Delay in following a Judge’s order to give a command or signal must be penalized, unless the Judge directs the delay because of some distraction or interference.

When given, signals must be inaudible, and the handler must not touch the dog. Any unusual noise or motion may be considered to be a signal. Signaling correction to a dog is forbidden and must be penalized.

Position of the arms and hands and movements of the body that aid the dog shall be considered additional signals. However, a handler may bend over at the waist when commanding Down or Stay, and a handler may bend the body and knees as far as necessary to bring his/her hand on a level with the dog’s eyes in giving a signal to a dog in the Heel position. In the Directed Retrieve exercise the body and knees may be bent to the extent necessary to give the direction to the dog.

Whistling or the use of a whistle is prohibited. The dog’s name may be used once immediately before any verbal command or before a verbal command and signal when these Guidelines permit command and/or signal. The name shall not be used with any signal not given simultaneously with a verbal command. The dog’s name, when given immediately before a verbal command, shall not be considered as an additional command, but a dog that responds to its name without waiting for the verbal command shall be scored as having anticipated the command. The dog should never anticipate the handler’s directions but must wait for the appropriate commands and/or signals. Moving forward at the heel without any command or signal other than the natural forward movement of the handler’s body shall not be considered as anticipation. Anticipation of commands will be given deductions.

Excessively loud commands by handlers to their dogs create a poor impression of 4-H obedience and should be avoided. Shouting is not necessary even in a noisy place if the dog is properly trained to respond to a normal tone of voice. Commands, which in the Judge’s opinion are excessively loud, will be penalized. An extra command and/or signal in any non-principal part of an exercise does not, in itself, constitute a failing score.

Section 6. Praise

Praise and petting are allowed between and after exercises, but points must be deducted from the total score for a dog that is not under reasonable control while

being praised. A handler shall not carry or offer food in the ring. There shall be a penalty for any dog that is picked up or carried at any time in the 4-H obedience ring.

Section 7. Handling between Exercises

In the Novice Classes the dog may be guided gently by the collar between exercises and to get it into proper position for an exercise. No other physical guidance, such as placing the dog in position with the hands or straightening the dog with the knees or feet, is permitted and shall be penalized even if occurring before or between the exercises. In the Open and Utility Classes there shall be a penalty for any dog that is physically guided at any time or that is not readily controllable. Posing for examination and holding for measurement are permitted. Imperfections in heeling between exercises will not be judged. In the Open and Utility Classes minor penalties shall be imposed for a dog that does not respond promptly to its handler's commands or signals before or between exercises.

Section 8. Misbehavior

Any display of fear or nervousness by the dog, or any uncontrolled behavior of the dog such as snapping, barking or running away from its handler, whether it occurs during an exercise, between exercises, or before or after judging, may be penalized according to the seriousness of the misbehavior. The deduction will be at least one ribbon placing. The Judge may excuse the dog from further competition in the class and the team will receive a white ribbon. If such behavior occurs during an exercise, the penalty must first be applied to the score for that exercise. Should the penalty be greater than the value of the exercise during which it is incurred, the additional points shall be deducted from the total score under Misbehavior. If such behavior occurs before or after the judging, or between exercises, the entire penalty shall be deducted from the total score.

Any dog that relieves itself at any time while in the ring for judging will be penalized 25 points.

The Judge may disqualify any dog that attacks or attempts to attack any person in the ring. He shall excuse a dog that attacks another dog or that appears dangerous to other dogs or exhibitors in the ring. This team shall receive a white ribbon.

Any exhibitor or spectator may be excused from the show for unsportsmanlike conduct. This team shall receive a white ribbon.

The Judge should ALWAYS talk to the exhibitor and

explain the reason behind the deduction or excuse from the ring.

Section 9. Orders and Minimum Penalties

The orders for the exercises and the standards for judging are set forth in the following chapters. The lists of faults are not intended to be complete, but minimum penalties are specified for most of the more common and serious faults. There is no maximum limit on penalties. A team that makes none of the errors listed may still fail to purple or receive a white ribbon for other reasons.

The following are some recommended deductions for judging:

There will be no scores of 0 for an exercise. The most points that can be taken from an exercise are half the total points for that exercise, except in the upper levels with the "Stay" exercises when up to a 20-point deduction can be made.

On the score sheets, the columns for point deductions will run from top to bottom - the closer to the bottom of the column the more severe the penalty.

- Minor – 1 to 2-point deductions per error.
- Substantial – 3 to 10 points per error.
- Major – up to half of the total points of the exercise can be deducted.

Section 10. Training on the Grounds

There shall be no drilling nor intensive or abusive training of dogs on the grounds or premises at a 4-H Obedience Trial. All dogs shall be kept on leash except when in the 4-H obedience ring or practice ring. These requirements shall not be interpreted as preventing a handler from moving normally about the grounds or premises with his/her dog at heel on leash. Signals or such commands in a normal tone, as are necessary and usual in everyday life in heeling a dog or making it stay are acceptable. Physical or verbal disciplining of dogs shall not be permitted except to a reasonable extent in the case of an attack on a person or another dog. The show officials, and SDSU Extension staff, shall be responsible for compliance with this Section, and shall investigate any reports of infractions.

No electric shock, training collars or muzzles are allowed on the grounds or premises at a 4-H Obedience Trial.

Section 11. Training and Disciplining in the Ring

The Judge shall not permit any handler to train his/her dog by excessive verbal commands or by moving toward the dog to correct it in any way, nor to practice any exercise in the ring either before or after s/he is judged. Any handler who does either will be excused from

further competition in the class. A dog whose handler disciplines it in the ring may be excused from further competition in the class and shall receive a white ribbon. The Judge should always explain why a dog and handler are excused.

NO food or treats of any kind should be with the handler while showing his/her dog. A deduction of one ribbon placing will occur, if noted.

The Judge must immediately report any abuse of a dog in the ring to the Show Officials.

Section 12. Abuse of Dogs

The 4-H Show Officials shall investigate any reports of abuse of dogs or severe disciplining of dogs on the grounds or premises of a show. Any person who conducts themselves in any manner against the best interests of the 4-H program, or who fails to comply with the requirements of Chapter 2, Section 9 of these Guidelines shall be dealt with promptly, during the Show if possible. The offender must be notified of the specific charges against him/her and be given an opportunity to address the charges. The Judge must immediately report any abuse of a dog in the ring to the Show Officials.

Any signs of dehydration or heat stress to the dog will not be allowed.

Section 13. Discipline of Exhibitors

Any inappropriate behavior as determined by the Show Officials and/or South Dakota 4-H (either in or outside of the show ring) may result in immediate suspension. Formal grievance procedures may be initiated according to the standards outlined in the South Dakota 4-H Fairbook.

An explanation of the noted inexcusable behavior and why it is not acceptable should always be given to the handler. The judges should encourage this to be a learning experience.

Section 14. Standardized Judging

Standardized judging is of paramount importance. Judges are not permitted to inject their own variations into the exercises but must see that each handler and dog executes the various exercises exactly as described in these Guidelines. A handler who is familiar with these Guidelines should be able to enter the ring under any Judge without having to inquire how the particular Judge wishes to have any exercise performed, and without being confronted with some unexpected requirement. The only exception to a variation in the exercise is when the pattern area is fouled and an adjustment in the pattern must be done.

Dogs are worked individually except in a group exercise. The recommended time per dog is five to seven minutes in the ring, not counting the group exercises. Variations to this can be made at the county level.

Section 15. Standard of Perfection

The Judge must carry a mental picture of the theoretically perfect performance in each exercise. He scores each dog and handler against this visualized standard which combines the utmost in willingness, enjoyment and precision on the part of the dog, and naturalness, gentleness and smoothness in handling. "Crispness" of the performance is always encouraged—square corners, good posture of the handler, efficiency and accuracy in performing exercises, etc. Speed is not to be considered as the equivalent to willingness and enjoyment. Lack of willingness or enjoyment on the part of the dog must be penalized. Lack of precision in the dog's performance, roughness in handling, military precision or dogmatic commands by the handler will also be penalized. There shall be no penalty of less than one point.

Section 16. Judge's Directions

The Judge's orders and signals should be given to the handlers in a clear and understandable manner, but in such a way that the work of the dog is not disturbed. Before starting each exercise, the Judge shall ask "Are you ready?" This question should be restated if something like a backwards collar is noted to give the handler a chance to correct the problem. At the end of each exercise the Judge shall say, "Exercise is finished." Each dog must be worked and judged separately except for the Group exercises. The judging of an exercise will begin when the Judge gives the first order, not before, unless the handler does not make the correction after the second "Are you ready?" is asked.

Section 17. No Added Requirements

No Judge shall require any dog or handler to do anything, nor penalize a dog or handler for failing to do anything, that is not required by these Guidelines. Anything outside the 4-H Guidelines is not allowed in a 4-H show. Judges should be certain to ask if the handler is familiar with the pattern being used and if he has any questions.

Section 18. Interference and Double Handling

A Judge who is aware of any assistance, interference or attempts to control a dog from outside the ring, must act promptly to stop such double handling or interference. He shall penalize the team substantially or, if in the Judge's opinion, deduct ½ of the points for the exercise during which aid was received.

Section 19. Re-judging

If a team has failed in a particular part of an exercise, it shall not ordinarily be re-judged nor given a second chance. If in the Judge's opinion the team's performance was prejudiced by peculiar and unusual conditions, the Judge may at his/her own discretion re-judge the team on the entire exercise. Should the Judge find it necessary to re-judge a team or teams from the Group exercises, they shall be re-judged with the next scheduled group within that class. The limits on the number of dogs allowed in the ring for the Group exercise shall remain consistent with Chapter 5, Section 10. Should there be no further group within that class, the dog or dogs to be re-judged shall immediately do the exercise alone. The team or teams involved will be re-judged only on the exercise in question.

Section 20. Explanations and Errors

The Judge is not required to explain his/her scoring and need not enter into any discussion with any contestant or adult who appears to be dissatisfied. However, after prizes have been awarded and the score sheets turned in, the Judge is encouraged, but not required, to discuss the scoring with the exhibitors. Any interested person who thinks that there may have been a mathematical error or an error in identifying a dog may report the facts to one of the Stewards or to the Show Officials so that the matter may be checked.

Chapter 3: Basic

Section 1. Basic

This class is reserved for teams where both the handler and dog have no prior experience in the obedience show ring. If the 4-H member or dog has shown in another organization, they go to Pre-novice.

Section 3. Basic Exercises and Scoring

Basic	Maximum Score
Heel on Leash	40 points
Figure Eight (on leash)	40 points
Sit for Exam (on leash)	40 points
Sit Stay (on leash)	40 points
Recall (on leash)	40 points
Maximum Total Score	200 points

Section 4. Heel on Leash and Figure Eight

The principal feature of this exercise is the ability of the dog and handler to work as a team. The orders for this exercise will be Forward and Exercise finished.

Signs, rather than verbal commands from the Judge, will be used for this exercise. Signs to be used are Right turn, Left turn, About turn, Slow, Normal, Fast and Halt/Sit.

Fast means that the handler must run, and the handler and dog must move forward at a noticeably accelerated speed.

Turns will be used only when the handler is moving at a normal speed. Both change of pace signs must be followed by a normal sign. Turn signs may be placed in any sequence and may be repeated. Two of each turn sign must be available for the Judge's use. The Halt/Sit sign will be used once at the end of the exercise. The Judge should standardize the heeling pattern for all dogs in the class.

The leash must be 6 feet in length. It may be held in either hand or in both hands, but the hands must be held in a natural position. Any tightening or jerking of the leash and use of any extra commands and/or signals will be penalized.

The handler will enter the ring with the dog on a loose leash and stand with the dog sitting in the heel position. The Judge will ask if the handler is ready before giving the order, Forward. The handler may give a command or signal to heel and will walk briskly and naturally with the dog on a loose leash. The dog should walk close to the handler's left side without swinging wide, lagging, forging or crowding. The dog must not interfere with the handler's freedom of motion at any time. At the Halt/Sit sign, the handler will stop. The dog shall sit straight and promptly in the heel position without command or signal. The Judge will order, "Exercise finished" at the completion of this exercise.

A one-time single phrase of praise or encouragement, by the handler to the dog, will be allowed without penalty. (Good, yes, nice, super, great, and atta boy/girl, are some examples of praise that would be allowed.) A verbal command to heel at the beginning of the exercise is the only command allowed during the heeling exercise.

Rally signs may be used. The signs may be placed either flat on the ground or on a stand. The course should be laid so that the signs are to the right of the handler.

Figure Eight

The principal feature of this exercise is the ability of the dog and handler to work as a team. The orders for this exercise are: Forward, Halt and Exercise finished.

For the Figure Eight, the handler will stand, and the dog will sit in heel position facing the Judge, midway between the two pylons placed, 8 feet apart. The Figure Eight will be performed on leash; the handler may go around either steward first. After the Judge asks, "Are you ready?" and gives the order, "Forward," the handler and dog will walk

briskly around and between the two pylons twice.

There will be no about turn, fast or slow, but the Judge must order at least one halt during this exercise and another halt at the end. After each halt, it is permissible for the handler to give a command or signal to heel before moving forward again.

A one-time single phrase of praise or encouragement, by the handler to the dog, will be allowed without penalty.

In scoring this exercise the Judge shall accompany the handler at a discreet distance so that he can observe any signals or commands given by the handler to the dog. The Judge must do so without interfering with either dog or handler.

Section 5. Heel on Leash and Figure Eight Scoring

Major deductions	Substantial deductions	Minor deductions
<ul style="list-style-type: none"> Unqualified heeling 	<ul style="list-style-type: none"> Handler continually adapts pace to dog Constant tugging on leash or guiding 	<ul style="list-style-type: none"> Improper heel position Occasional tight leash Forging or crowding handler Lagging or sniffing Extra command to heel or sit Handler error Heeling wide including turns and abouts No change of pace including fast and slow No sits or poor sits Lack of naturalness or smoothness

Section 6. Sit for Examination

The principal feature of this exercise is that the dog sits in position before and during the examination without displaying resentment. Orders are: Sit your dog and Leave when you are ready, Back to your dog and Exercise finished. This exercise is to be performed with the dog on a 6-foot leash.

On the Judge's order, the handler will command the dog to sit. The handler will then stand with the dog sitting in the heel position, give the command and/or signal to stay, walk straight forward about 6 feet to the end of the leash, turn and face the dog. The Judge will approach the dog from the front. Using the fingers and palm of one hand, the Judge will touch only the dog's head. On the order

“Back to your dog,” the handler will walk around behind the dog and return to the heel position. The handler may gather the leash at any time while returning to the dog. The dog must remain sitting until the Judge has said, “Exercise finished.”

Section 7. Sit for Examination Scoring

The scoring of this exercise will not start until the handler has given the command and/or signal to Stay, except for such things as rough treatment of the dog by its handler or active resistance by the dog to its handler's attempts to make it sit.

Major deductions	Substantial deductions	Minor deductions
<ul style="list-style-type: none"> Stands, downs or moves away from place it was left before or during examination 	<ul style="list-style-type: none"> Extra command after given the command to stay 	<ul style="list-style-type: none"> Dog moves its feet Dog stands or moves away after examination is complete Shyness Tightening of the leash during the exercise Handler error Out of position stay

Section 8. Sit Stay on Leash

The principal feature of this exercise is that the dog remains in the sit position for 45 seconds. Orders for this exercise are: Sit your dog, Leave your dog, Return to your dog and Exercise finished.

The handler will stand with the dog sitting in heel position. Prior to starting the exercise, the Judge will ask if the handler is ready. When the Judge gives the order “Sit your dog,” the handler will command and/or signal the dog to sit, if they are not already sitting. The Judge will order “Leave your dog,” and the handler will give a command and/or signal to stay and immediately proceed to the end of the leash and turn to face the dog. The dog will remain seated for 45 seconds. At the Judge's command of “Return to your dog,” the handler will approach the dog from the front, and proceed to walk around and in back of the dog to the heel position. Once the handler has returned to heel position, the Judge will give the order “Exercise finished.” The Judge should not deduct points if the leash either touches or does not touch the ground.

Section 9. Sit Stay on Leash Scoring

Scoring of the exercise will not start until after the Judge has ordered the handler to sit his dog, except for such things as rough treatment of a dog by its handler or

resistance by a dog to its handler's attempts to make it sit.

Major deductions	Substantial deductions	Minor deductions
<ul style="list-style-type: none"> Dog moves a substantial distance away from place it was left Gets out of sit position Repeated barking and whining Additional command or signal by the handler 	<ul style="list-style-type: none"> Dog moves a short distance from where it was left Barks or whines once or twice Dog changes position after handler returns to heel position 	<ul style="list-style-type: none"> Minor whine or bark Excessively loud commands Handler error Out of position stay

Section 10. Recall

Recall on Leash (Basic)

The principal features of this exercise are that the dog stay where left until called by the handler, and that the dog responds promptly. Orders are: Leave your dog, Call your dog and Exercise finished. On order from the Judge, the handler may give a command and/or signal to the dog to stay in the sit position. The handler will then walk forward, to the end of the 6-foot leash, and turn to face the dog.

On the Judge's order or signal, the handler will command and/or signal the dog to come. The dog must come directly, at a brisk trot or gallop, and sit in front near the handler. The dog must be close enough to its handler so that the handler could touch its head without excessive bending, stretching or moving either foot.

A one-time single phrase of praise or encouragement while the dog is coming to the handler will be allowed without penalty. (Good, yes, nice, super, great, atta boy/girl, are some examples of praise that would be allowed.)

Section 11. Recall Scoring

Major deductions	Substantial deductions	Minor deductions
<ul style="list-style-type: none"> Dog does not come on first command or signal Dog moved from position 	<ul style="list-style-type: none"> Extra command or signal to stay Anticipated recall command Dog sat out of reach Dog leaves handler 	<ul style="list-style-type: none"> Dog stood or lay down or touched handler Slow response or sat between feet No sit or poor sit Lack of naturalness or smoothness Handler error Out of position stay

Chapter 4: Pre-Novice

Section 1. Pre-Novice

Teams having previously competed at a county or state show will move up to Pre-Novice regardless of county or state ribbon placing.

Section 2. Pre-Novice Exercises and Scoring

Exercise	Points
Heel on Leash	50
Figure Eight on Leash	25
Stand for Examination (off leash)	40
Recall (off leash)	45
Stay—Down	40
Maximum Total Score	200

Section 3. Heel on Leash and Figure Eight

The purpose of this exercise is to demonstrate the ability of the handler and dog to work as a team. Orders for this exercise are Forward, Halt, Right Turn, Left Turn, About Turn, Slow, Normal and Fast. All About Turns will be right about turns. Orders for halts and turns will be given only when the handler is moving at normal speed. The other orders may be given in any sequence and turns, and halts may be repeated.

The leash must be 6 feet in length. It may be held in either hand or in both hands, but the hands must be held in a natural position. Any tightening or jerking of the leash and use of any extra commands and/or signals will be penalized.

The handler will enter the ring with the dog on a loose leash and stand with the dog sitting in the heel position. The Judge will say to the handler, "Are you ready?" The handler should answer either "Yes" or "No." When the handler is ready the Judge will give the order, Forward. The handler and dog walk briskly, and in a natural manner, with the dog on a loose leash. The dog should walk close to the handler's left side without swinging wide, lagging, forging or crowding. The area from the dog's head to shoulder should be in line with the handler's left hip. The dog must not interfere with the handler's freedom of motion at any time. The handler may give a command OR signal to heel, NOT both.

Remaining Orders given by the Judge:

- Halt:** When the Judge says, "Halt," the handler stops. The dog should sit straight and promptly in the heel position. The handler should not give a command OR signal to the dog. The dog should not move until the handler again moves forward on the Judge's command. After each halt, the handler is permitted to give a command OR signal to heel before again moving forward.

- **Right Turn:** When the Judge says, “Right Turn,” the handler and dog make a 90-degree (90°) turn to the right. This turn should be made squarely.
- **Left Turn:** When the Judge says, “Left Turn,” the handler and dog make a 90-degree (90°) turn to the left. This turn should be made squarely.
- **About Turn:** When the Judge says, “About Turn,” the handler and dog make a 180-degree (180°) turn to the right.
- **Slow:** When the Judge says, “Slow,” the handler and dog walk at a noticeably slower pace than normal.
- **Normal:** The handler and dog begin the heeling pattern at a normal pace. After the Judge gives the order to walk “Slow” or “Fast,” he/she will give the order, “Normal.” The handler and dog then return to a normal pace.
- **Fast:** When the Judge says, “Fast,” the handler and dog must run, moving forward at a noticeably accelerated pace.

At the completion of the Heel exercise, the Judge will say, “Exercise finished.” At this time, it is appropriate for the handler to praise his/her dog.

Figure Eight

For this exercise, the handler will stand, and the dog will sit in heel position facing the Judge, midway between the two pylons placed eight feet apart. The Judge will ask, “Are you ready?” The handler will say, “Yes” or “No.” After the handler and dog are ready, the Judge will give the order, “Forward.” The handler may choose to go in either direction. The handler and dog will walk briskly around and between the two pylons twice. The Judge will order at least one halt during this exercise and another halt at the end. There will be no about turn, fast or slow during this exercise. At the completion of the Figure Eight exercise, the Judge will say, “Exercise finished.” At this time, it is appropriate for the handler to praise his/her dog.

The leash is removed for the remaining exercises and kept by the handler. When the handler removes the leash, s/he may hold it in any manner using one or both hands, or draped around the neck.

Section 4. Heel on Leash and Figure Eight Scoring

In scoring this exercise the Judge shall accompany the handler at a discreet distance so that he can observe any signals or commands given by the handler to the dog. The Judge must do so without interfering with either dog or handler.

Major deductions	Substantial deductions	Minor deductions
<ul style="list-style-type: none"> • Unqualified heeling 	<ul style="list-style-type: none"> • Handler continually adapts pace to dog • Constant tugging on leash or guiding 	<ul style="list-style-type: none"> • Improper heel position • Occasional tight leash • Forging or crowding handler • Lagging or sniffing • Extra command to heel or sit • No change of pace including fast and slow on the Heel on Leash • No sits or poor sits • Lack of naturalness or smoothness • Handler error • Out of position stay

Section 5. Stand for Examination off Leash

The purpose of this exercise is for the dog to stand and stay in position before, during and after the examination without displaying resentment. The orders given by the Judge are: Stand your dog, Leave when you are ready, Back to your dog and Exercise finished.

On the Judge’s order, the handler will take his/her dog to the place indicated by the Judge and have the dog sit in heel position. On the Judge’s order to Stand your dog and Leave when you are ready the handler will stand/pose the dog by the method of the handler’s choice, taking any reasonable time if he/she chooses to pose the dog as in the show ring. The handler will then stand with the dog in the heel position and give the command and/or signal to stay. The handler will then leave from heel position, walk straight forward about 6 feet, and turn and face the dog.

The Judge will approach the dog from the front. Using the fingers and palm of one hand, the Judge will touch the dog’s head, body and hindquarters. On the order Back to your dog, the handler will walk around behind the dog and return to the heel position. The dog must remain standing, without moving its feet, until the Judge has said, “Exercise finished.” At this time it is appropriate for the handler to praise his/her dog. The dog must not show any shyness or resentment during this exercise.

Section 6. Stand for Examination Scoring

The scoring of this exercise will not start until the handler has given the command and/or signal to Stay, except for

such things as rough treatment of the dog by its handler or active resistance by the dog to its handler's attempts to make it stand.

Major deductions	Substantial deductions	Minor deductions
<ul style="list-style-type: none"> Dog moves away or sits before examination 	<ul style="list-style-type: none"> Dog moves away or sits during examination Dog shows shyness or resentment 	<ul style="list-style-type: none"> Dog resists handler posing Extra command to stay Dog moves slightly Dog sits as handler returns Lack of naturalness or smoothness Handler error Out of position stay

Section 7. Recall off leash

The purpose of this exercise is for the dog to stay where left until called by the handler, and for the dog to respond promptly to the handler's command or signal to come. The orders given by the Judge are: Leave your dog, Call your dog and Finish. The handler will take the dog to the place designated by the Judge and have the dog sit in the heel position. On the Judge's order, Leave your dog, the handler may give a command and/or signal to the dog to stay in the sit position. The handler will then walk forward approximately 20 feet, turn to face the dog, standing with the hand not holding the leash hanging naturally at the side of the body. On the Judge's order or signal to Call your dog, the handler will either command OR signal the dog to come, NOT both. The dog must come directly, at a brisk trot or gallop and sit straight, centered in front of the handler. The dog must be close enough to its handler so that the handler could touch its head without excessive bending, stretching or moving either foot. The dog should not touch the handler or sit between the handler's feet.

On the Judge's order to Finish, the handler will give a command OR signal to finish, NOT both. The dog must go promptly to heel position and sit straight at heel. The method by which the dog goes to heel position is optional.

Section 8. Recall Scoring

Major deductions	Substantial deductions	Minor deductions
<ul style="list-style-type: none"> Dog does not come on first command or signal Dog moved from position 	<ul style="list-style-type: none"> Extra command or signal to stay Anticipated recall command Dog sat out of reach Dog leaves handler 	<ul style="list-style-type: none"> Dog stood, downs or touched by handler Slow response or sat between feet No sit or poor sit No finish or poor finish Extra command to finish Lack of naturalness or smoothness Handler error Out of position stay

Section 9. Down Stay – Handler Walk around the Ring

The principal feature of this exercise is that the dog remains in the down position. Orders for this exercise are: Down your dog, Leave your dog and Exercise finished.

The handler will stand with the dog sitting in heel position in approximately the center of the ring. Prior to starting the exercise, the Judge will ask if the handler is ready. When the Judge gives the order Down your dog, the handler will command and/or signal the dog to down. The Judge will order Leave your dog, and the handler will give a command and/or signal to stay and then walk straight forward to the end of the ring. The handler will then turn either to the right or left as directed by the Judge and walk the perimeter of the ring. Upon completing a full perimeter walk, the handler will approach the dog from the front, and proceed to walk around and in back of the dog to the heel position. Once the handler has returned to heel position, the Judge will give the order Exercise finished.

Section 10. Down Stay Scoring

Scoring of the exercise will not start until after the Judge has ordered the handler to leave his/her dog, except for such things as rough treatment of a dog by its handler or resistance by a dog to its handler's attempts to make it Lie Down.

Major deductions	Substantial deductions	Minor deductions
<ul style="list-style-type: none"> • Dog moves a substantial distance away from place it was left • Gets out of down position before handler's first turn • Repeated barking and whining • Additional command or signal by the handler 	<ul style="list-style-type: none"> • Dog moves a short distance from where it was left • Dog stood or sat after handler's first turn • Barks or whines once or twice • Dog changes position after handler returns to heel position • Forces into position 	<ul style="list-style-type: none"> • Minor whine or bark • Excessively loud commands • Dog stood or sat after handler's last turn • Handler error • Out of position stay

Chapter 5: Novice

Section 1. Novice Class

The Novice class is for handler and dog that have received a purple at the State 4-H Dog Show in Pre-Novice. Teams may move up to Novice regardless of County or State ribbon placing.

Section 2. Novice Exercises and Scoring

Exercises	Points
Heel on Leash and Figure Eight	35
Stand for Examination off leash	30
Heel Free	45
Recall	30
Long Sit	30
Long Down	30
Maximum Total Score	200

Section 3. Heel on Leash and Figure Eight

The principal feature of this exercise is the ability of the dog and handler to work as a team. Orders for the exercise are Forward, Halt, Right turn, Left turn, About turn, Slow, Normal and Fast. Fast signifies that the handler must run with handler and dog moving forward at noticeably accelerated speed. In executing the About Turn, the handler will always do a Right About Turn. Orders for Halts and Turns will be given only when the handler is moving at a Normal speed.

The orders may be given in any sequence and may be repeated as necessary, but the Judge shall attempt to standardize the heeling pattern for all dogs in any class. The leash may be held in either hand or in both hands, provided the hands are in a natural position. However, any tightening or jerking of the leash or any act, signal or command which in the Judge's opinion gives the dog assistance shall be penalized.

The handler shall enter the ring with his/her dog on a loose leash and stand with the dog sitting in the Heel position. The Judge shall ask if the handler is ready before giving the order, Forward. The handler may give a command or signal to Heel and shall walk briskly and in a natural manner with his/her dog on a loose leash. The dog shall walk close to the left side of the handler without swinging wide, lagging, forging or crowding. Whether heeling or sitting, the dog must not interfere with the handler's freedom of motion at any time. At each order to Halt, the handler will stop after a few steps and his/her dog shall Sit straight and promptly in the Heel position without command or signal and shall not move until the handler again moves forward on the Judge's order. It is permissible after each Halt, before moving again, for the handler to give a command or signal to Heel. The Judge

shall say, "Exercise finished," after this portion of the exercise.

Before starting the Figure Eight the Judge shall ask if the handler is ready. The Figure Eight signifies that on specific orders from the Judge to Forward and Halt, the handler and dog, from a starting position about equidistant from the two pylons and facing the Judge, shall walk briskly twice completely around and between the two pylons placed eight feet apart. The handler may choose to go in either direction. There shall be no About Turn or Fast or Slow in the Figure Eight, but the Judge must order at least one Halt during and another Halt at the end of this portion of the exercise.

Section 4. Heel on Leash and Figure Eight Scoring

In scoring this exercise the Judge shall accompany the handler at a discreet distance so that he can observe any signals or commands given by the handler to the dog. The Judge must do so without interfering with either dog or handler.

Major deductions	Substantial deductions	Minor deductions
<ul style="list-style-type: none"> Unqualified heeling 	<ul style="list-style-type: none"> Handler continually adapts pace to dog Constant tugging on leash or guiding 	<ul style="list-style-type: none"> Improper heel position Occasional tight leash Forging or crowding handler Lagging or sniffing Extra command to heel Heeling wide including turns and abouts No change of pace including fast and slow No sits or poor sits Lack of naturalness or smoothness Handler error

Section 5. Stand for Examination

The principal features of this exercise are that the dog stands in position before and during the examination and that it does not display resentment. Orders are Stand your dog and leave when ready, Return to your dog and Exercise finished. There will be no further command from the Judge to the handler to leave the dog.

On the Judge's order, the handler shall remove the leash and give it to a Steward who shall place it on the Judge's table or other designated place. The handler will take his

dog, minimal guidance by the collar is allowed, to the place indicated by the Judge, and on the Judge's order, the handler will stand and/or pose his dog off leash. The 4-H member may use the method of his choice, taking reasonable time if he chooses to pose the dog as in the show ring. When he is ready, the handler will stand with the dog in the heel position, and give his command and/or signal to the dog to Stay, walk forward about 6 feet in front of the dog, turn around and stand facing the dog.

The Judge shall approach the dog from the front, and shall touch only the dog's head, body and hindquarters, using the fingers and palm of one hand only. He shall then order, "Return to your dog," whereupon the handler shall walk around behind his dog and return to the Heel position. The dog must remain standing until after the Judge has said, "Exercise finished."

Section 6. Stand for Examination, Scoring

The scoring of this exercise will not start until the handler has given the command and/or signal to Stay, except for such things as rough treatment of the dog by its handler or active resistance by the dog to its handler's attempts to make it stand.

Major deductions	Substantial deductions	Minor deductions
<ul style="list-style-type: none"> Dog moves away or sat before examination 	<ul style="list-style-type: none"> Dog moves away or sat during examination Dog shows shyness or resentment 	<ul style="list-style-type: none"> Dog resists handler posing Extra command to stay Dog moves slightly Dog sits as handler returns Lack of naturalness or smoothness Handler error Out of position stay

Section 7. Heel Free Performance and Scoring

This exercise shall be executed in the same manner as Heel on Leash and Figure Eight except that the dog shall be off leash and that there shall be no Figure Eight. Orders and scoring shall also be the same. A dog leaving the ring will receive a white ribbon.

Section 8. Recall

The principal features of this exercise are that the dog stays where left until called by its handler, and that the dog responds promptly to the handler's command or signal to Come. Orders are Leave your dog, Call your dog and Finish.

On order from the Judge, the handler may give command and/or signal to the dog to stay in the Sit position while

the handler walks forward about 35 feet to the other end of the ring, where he shall turn and stand in a natural manner (upright, with arms at sides) facing his dog. On Judge's order or signal, the handler will give command or signal for the dog to Come. The dog must come directly in at a brisk trot or gallop and Sit straight, centered immediately in front of the handler's feet, close enough that the handler could readily touch its head without moving either foot or having to stretch forward. The dog must not touch the handler or sit between his feet. On Judge's order the handler will give command or signal to Finish and is allowed to take one step and the dog must go smartly to the Heel position and Sit. The manner in which the dog finishes shall be optional with the handler provided that it is prompt and that the dog Sits straight at Heel.

Section 9. Recall Scoring

Major deductions	Substantial deductions	Minor deductions
<ul style="list-style-type: none"> • Dog does not come on first command or signal • Dog moved from position • Leaves ring 	<ul style="list-style-type: none"> • Extra command or signal to stay • Anticipated recall command • Dog sat out of reach • Dog leaves handler 	<ul style="list-style-type: none"> • Dog stood, downs or touched handler • Slow response or sat between feet • No sit or poor sit • No finish or poor finish • Extra command to finish • Lack of naturalness or smoothness • Handler error • Out of position stay

Section 10. Sit or Down (Group Exercises)

The principal feature of these exercises is that the dog remains in the Sit or Down position, whichever is required by the particular exercise. Orders are Sit your dogs or Down your dogs, Leave your dogs and Back to your dogs. All the competing dogs in the class take these exercises together, unless there are 12 or more dogs. Then, at the Judge's option, the class will be judged in groups of not less than two nor more than 12 dogs. Classes may be combined provided there are not more than 12 dogs competing in the combined classes. For a single dog, an on-leash dog/handler may be added for companionship. The Judge shall divide his/her class into approximately equal sections. The Group exercises shall be judged after each section.

The dogs in the ring shall be lined up according to the Judge's direction. Upon request from the Judge, handlers shall give a command and/or signal to stay and

immediately proceed to the end of the 6 foot leash and turn to face the dog.

For the Long Sit the handlers shall, On the Judge's order, command and/or signal their dogs to Sit if they are not already sitting. On further order from the Judge to leave their dogs, the handlers shall give a command and/or signal to Stay and immediately leave their dogs and immediately proceed to the end of the 6 foot leash and turn to face the dog. If a dog gets up and starts to roam, follows its handler or moves so as to interfere with another dog, the Judge shall promptly instruct the handler or one of the Stewards to take the dog out of the ring or to keep it away from the other dogs.

After one minute from the time he has ordered the handlers to leave their dogs, the Judge will give the order to return, then the handlers must promptly go back to their dogs, each walking around and in back of his/her own dog to the Heel position. The dogs must not move from the Sitting position until after the Judge has said, "Exercise finished." The Judge shall not give the order Exercise finished, until the handlers have returned to the Heel position.

Before starting the Long Down, the Judge shall ask if the handlers are ready. The Long Down is done in the same manner as the Long Sit except that the handlers shall, On the Judge's order, down their dogs to a position facing the opposite side of the ring, without touching either the dogs or their collars. Additionally, the Judge will order the handlers to return after three minutes. The dogs must not move from the Down position until after the Judge has said, Exercise finished.

The dogs shall not be required to sit at the end of the Down exercise.

Section 11. Group Exercises Scoring

During these exercises the Judge shall stand so that all the dogs are in his/her line of vision, and he can see all the handlers in the ring without having to turn around.

Scoring of the exercises will not start until after the Judge has ordered the handlers to leave their dogs, except for such things as rough treatment of a dog by its handler or resistance by a dog to its handler's attempts to make it Sit or Lie Down. A handler whose dog assumes a position in such a manner that it could interfere with an adjacent competing dog shall be required to reposition his/her dog and shall also be substantially penalized; in extreme cases the dog may be excused with a white ribbon. The Judge shall not give the order, Exercise finished, until the handlers have returned to the Heel position.

Major deductions	Substantial deductions	Minor deductions
<ul style="list-style-type: none"> • Stood, sat or down within 15 seconds 	<ul style="list-style-type: none"> • Stood, sat or down within 15–30 seconds (sit stay) or 15 seconds–2 minutes (down stay) • Repeated whines or barks • Out of position stay • Forcing into position 	<ul style="list-style-type: none"> • Stood, sat or down within 30–60 seconds (sit stay) or 2–3 minutes (down stay) • Minor move before handler returns • Minor whine or bark • Excessively loud commands • Handler error • Out of position stay

Chapter 6: Graduate Novice

Section 1. Graduate Novice Class

The Graduate Novice class is for the handler and dog that have received a purple at the State 4-H Dog Show in Novice. Teams may move up to Graduate Novice regardless of County or State ribbon placing.

Section 2. Graduate Novice Exercises and Scoring

Exercises	Points
Heel Free and Figure Eight (Off Leash)	40
Drop on Recall	40
Dumbbell Recall	30
Recall over High Jump	30
Recall over Broad Jump	30
Long Down (Handler out of sight)	30
Maximum Total Score	200

Section 3. Heel Free and Figure Eight Off Leash

The principal feature of this exercise is the ability of the dog and handler to work as a team. Orders for the exercise are Forward, Halt, Right turn, Left turn, About turn, Slow, Normal and Fast. Fast signifies that the handler must run with handler and dog moving forward at noticeably accelerated speed. In executing the About Turn, the handler will always do a Right About Turn. Orders for Halts and Turns will be given only when the handler is moving at a Normal speed.

The orders may be given in any sequence and may be repeated as necessary, but the Judge shall attempt to standardize the heeling pattern for all dogs in any class. The leash may be held in either hand or in both hands, provided the hands are in a natural position. However, any tightening or jerking of the leash or any act, signal or command which in the Judge's opinion gives the dog assistance shall be penalized.

The handler shall enter the ring with his/her dog on a loose leash and stand with the dog sitting in the Heel position. The Judge shall ask if the handler is ready. The dog will be unleashed, and the leash given to the Judge. The handler may give a command or signal to Heel and shall walk briskly and in a natural manner. The dog shall walk close to the left side of the handler without swinging wide, lagging, forging or crowding. Whether heeling or sitting, the dog must not interfere with the handler's freedom of motion at any time. At each order to Halt, the handler will stop after a few steps and his/her dog shall sit straight and promptly in the heel position without command or signal and shall not move until the handler again moves forward on the Judge's order. It is permissible after each Halt, before moving again, for the handler to give a command or signal to heel. The Judge shall say, "Exercise finished," after this portion of the exercise.

Before starting the Figure Eight the Judge shall ask if the handler is ready. The dog will be unleashed, and the leash given to the Judge. The Figure Eight signifies that on specific orders from the Judge to Forward and Halt, the handler and dog, from a starting position about equidistant from the two pylons and facing the Judge, shall walk briskly twice completely around and between the two pylons placed, 8 feet apart. The handler may choose to go in either direction. There shall be no About Turn or Fast or Slow in the Figure Eight, but the Judge must order at least one Halt during and another Halt at the end of this portion of the exercise.

Section 4. Heel Free and Figure Eight Off Leash

In scoring this exercise the Judge shall accompany the handler at a discreet distance so that he can observe any signals or commands given by the handler to the dog. The Judge must do so without interfering with either dog or handler.

Major deductions	Substantial deductions	Minor deductions
<ul style="list-style-type: none"> Unqualified heeling 	<ul style="list-style-type: none"> Handler continually adapts pace to dog Constant tugging on leash or guiding No change of pace including fast and show Extra command to heel No sits or poor sits 	<ul style="list-style-type: none"> Improper heel position Occasional tight leash Forging or crowding handler Lagging or sniffing Heeling wide including turns and abouts No change of pace including fast and slow Lack of naturalness or smoothness Handler error

Section 5. Drop on Recall

The principal features of this exercise are that the dog stays where left until called by its handler, that it responds promptly to the handler's command or signal to Come and to Drop and remains in the Down position until again called or signaled to Come. The dog will be judged on the promptness of its response to command or signal and not on its proximity to a designated point.

Orders for the exercise are Leave your dog, Call your dog, a signal to Drop the dog, another Call your dog and Finish. The Judge's signal must be clear to the handler but not obvious or distracting to the dog. On the Judge's order, the handler may give command and/or signal for the dog to Stay in the Sit position while the handler walks forward about 35 feet to the other end of the ring, where he shall turn and stand in a natural manner (upright, arms at sides) facing his/her dog. The Judge will position himself behind the dog, facing the handler. On Judge's order or signal, the handler shall give command or signal to Come and the dog must start directly in at a brisk trot or gallop. On the Judge's arm or hand signal, the handler shall give command and/or signal to Drop, and the dog must immediately drop completely to the Down position, where he must remain until, on Judge's order or signal, the handler again gives command or signal to Come. Once commanded to Come, the dog must come directly in at a brisk trot or gallop and Sit straight, centered immediately in front of the handler's feet, close enough that the handler could readily touch its head without moving either foot or having to stretch forward. The dog must not touch the handler or sit between his/her feet. On Judge's order the handler will give command or signal to Finish and the dog must go smartly to the Heel position and Sit. The manner in which the dog finishes shall be

optional with the handler provided that it is prompt and that the dog Sit straight at Heel.

Section 6. Drop on Recall Scoring

Major deductions	Substantial deductions	Minor deductions
<ul style="list-style-type: none"> Dog does not come on first command or signal after drop Dog does not drop on first command or signal 	<ul style="list-style-type: none"> Extra command or signal to stay after handler leaves Dog moved from place left Dog anticipated drop, recall or come in Dog sat out of reach Out of position stay 	<ul style="list-style-type: none"> Dog stood or downs Extra command or signal before leaving Dog touched handler Slow response or sat between feet Slow return or drop No sit or poor sit No finish or poor finish Lack of naturalness or smoothness Handler error

Section 7. Dumbbell Recall

The purpose of this exercise is to show that the dog can perform a recall off leash while holding a dumbbell. This exercise will be performed like the Novice Recall but with the dog holding the dumbbell. In addition to the Novice Recall, the dog will promptly take, hold and deliver the dumbbell when commanded.

The Judge's orders are Give your dog the dumbbell, Leave your dog, Call your dog, Take it and Finish.

The handler will stand with the dog sitting in the heel position in a place designated by the Judge. When the Judge orders, "Give your dog the dumbbell," the handler will present the dumbbell with one command. The dog must accept it readily and hold it. When the Judge orders, the handler may give the command and/or signal to stay and will walk forward to the other end of the ring and turn to face the dog. On the Judge's order or signal, the handler will command or signal the dog to come. The dog must come directly at a brisk trot or gallop.

When the dog is sitting in front of the handler, the Judge will order, "Take it," and the handler will give a command and take the dumbbell. The dog must willingly give the dumbbell on command to the handler. The finish will be done as in the Novice Recall.

Section 8. Dumbbell Recall Scoring

Major deductions	Substantial deductions	Minor deductions
<ul style="list-style-type: none"> • Fails to take dumbbell on first command • Handler forces dumbbell into dog's mouth • Dog doesn't come on first command or signal 	<ul style="list-style-type: none"> • Extra command to take dumbbell • Extra command or signal to stay • Dog drops dumbbell • Dog moves from place left • Dog anticipates recall • Dog sat out of reach • Out of position stay 	<ul style="list-style-type: none"> • Dog touches handler • Slow response or sat between feet • Slow retrieve • Dog mouths dumbbell • Dog fails to release dumbbell • No sit or poor sit • No finish or poor finish • Lack of naturalness or smoothness • Handler error

Section 9. Recall Over High Jump

The purpose of the exercise is for the dog to stay until directed to jump, clear the jump on a single command or signal, and immediately return to sit in front of the handler. The Judge's orders are Leave your dog, Call your dog and Finish.

The handler will stand with the dog sitting in the heel position at least 8 feet from the jump. When the Judge orders, "Leave your dog," the handler will give the command and/or signal to stay, go at least 8 feet beyond the other side of the high jump, and turn and face the dog as in the Novice Recall. On the Judge's order, the handler will give the command or signal to jump. The dog must clear the high jump without touching it and, without any further command or signal, immediately sit in front of the handler. The finish is done as in the Novice Recall. In South Dakota 4-H, all dogs in obedience will jump the same jump heights as in agility and rally.

Height of dog at withers	Height to be jumped
Less than 10 inches	4 inches
Greater than 10 inches to 15 inches	8 inches
Greater than 15 inches to 20 inches	12 inches
Greater than 20 inches	16 inches

New for 2024 – Veteran Jumps For dogs 7 years and older, jumps will be one height lower than their measured jump height.

The high jump will be 5 feet wide and built to provide increments from 4 inches to 16 inches. The uprights of the high jump will be 4 feet high. It is suggested that the bottom board measure 8 inches down from its top to the floor or ground. In addition, another 8-inch board, and

two 4-inch boards will be needed to create the four jump heights. A 6-inch board may also be used. The jump will be a flat white. The height of each board will be indicated in black 2-inch numbers.

Section 10. Recall Over High Jump Scoring

Major deductions	Substantial deductions	Minor deductions
<ul style="list-style-type: none"> • Dog does not come on first command or signal • Dog does not jump on first command or signal 	<ul style="list-style-type: none"> • Extra command or signal to stay • Extra signal or command to jump • Dog moved from place left • Dog anticipated recall • Dog does not clear jump • Dog sat out of reach • Out of position stay 	<ul style="list-style-type: none"> • Dog stood or lay down • Dog touches handler • Slow response to recall • Dog sits between feet • No sit or poor sit • No finish or poor finish • Minor jump touch • Handler error • Dog sat out of reach

Section 11. Recall Over Broad Jump

The purpose of this exercise is for the dog to stay where left until directed to jump, clear the jump on a single command or signal, and that the dog immediately return to sit in front of its handler after it has jumped. Each dog will jump twice the height it did for the high jump.

The handler will stand with the dog sitting in the heel position at least 8 feet from the jump, facing the lowest side of the lowest hurdle. When the Judge orders, Leave your dog, the handler will give the command and/or signal to stay, go at least 8 feet beyond the last hurdle, and turn and face the dog as in the Novice Recall. On the Judge's order, the handler will give the command or signal to jump. The dog must clear the entire distance of the broad jump without touching it and, without any further command or signal, immediately sit in front of the handler and finish as in the Novice Recall.

The broad jump will consist of four white telescoping hurdles, all about 8 inches wide. The largest hurdle will measure about 5 feet long and about 6 inches at the highest point. In the ring, they will be arranged in order of size, evenly spaced, covering a distance equal to twice the height of the high jump setting for each dog. Four hurdles will be used for a jump of 32 inches, three for 24 inches and two for a jump of 16 inches and one for an 8-inch jump.

When decreasing the number of hurdles in the jump, the highest hurdle will be removed first. It is the Judge's responsibility to see that the distance jumped by each dog is in accordance with these regulations.

Section 12. Recall Over Broad Jump Scoring

Major deductions	Substantial deductions	Minor deductions
<ul style="list-style-type: none"> • Dog does not come on first command or signal • Dog does not jump on first command or signal • Dog walks over any part of jump 	<ul style="list-style-type: none"> • Extra command or signal to stay • Extra signal or command to jump • Dog moved from place left • Dog anticipated recall • Dog does not clear jump • Dog sat out of reach • Out of stay position 	<ul style="list-style-type: none"> • Dog stood or lay down • Dog touches handler • Slow response to recall • Dog sits between feet • No sit or poor sit • No finish or poor finish • Minor jump touch • Handler error

Section 13. Long Down

During the Long Down exercise, the Judge shall stand so all the dogs and handlers are in his line of vision at all times. Class size will be no less than two dogs and no more than 12. For a single dog, an on-leash dog/handler may be added for companionship. Upon request from the Judge, the handlers shall command and/or signal the dog to down. The Judge will order Leave your dog, and the handler will give a command and/or signal to stay and immediately proceed to the end of the 6 foot leash and turn to face the dog.

On the Judge's order, the handlers shall return to their dogs. The Judge shall not give the order, Exercise finished, until the handlers have returned to the heel position.

Section 14. Long Down Scoring

During these exercises the Judge shall stand so that all of the dogs are in his/her line of vision, as well as the handlers in the ring, or leaving and returning to the ring, without having to turn around. Scoring of the exercises will not start until after the Judge has ordered the handlers to leave their dogs, except for such things as rough treatment of a dog by its handler or resistance by a dog to its handler's attempts to make it sit or lie down.

A handler whose dog assumes a position in such a manner that it could interfere with an adjacent competing dog shall be required to reposition his/her dog and shall also be substantially penalized; in extreme cases the dog may be excused with a white ribbon.

Major deductions	Substantial deductions	Minor deductions
<ul style="list-style-type: none"> • Dog stood, sat or downs within 15 seconds 	<ul style="list-style-type: none"> • Stood, sat or downs within 1 to 3 minutes. • Repeated whines or barks • Forcing into position 	<ul style="list-style-type: none"> • Dog stood or sit within 3-5 minutes • Minor move before handler returns • Minor whine or bark • Excessively loud commands • Handler error

Chapter 7: Open

Section 1. Open Class

The Open class is for the handler and dog that have received a purple at the State 4-H Dog Show in Graduate Novice. Teams may move up to Open regardless of County or State ribbon placing.

Section 2. Open Exercises and Scoring All exercises will be performed Off Leash

Open Exercises	Points
Heel Free and Figure Eight	40
Drop on Recall	30
Retrieve on Flat	20
Retrieve over High Jump	30
Broad Jump	20
Long Sit	30
Long Down	30
Maximum Total Score	200

Section 3. Heel Free and Figure Eight

The principal feature of this exercise is the ability of the dog and handler to work as a team. Orders for the exercise are Forward, Halt, Right turn, Left turn, About turn, Slow, Normal and Fast. Fast signifies that the handler must run with the team moving forward at noticeably accelerated speed. In executing the About Turn, the handler will always do a Right About Turn. Orders for Halts and Turns will be given only when the handler is moving at a Normal speed. Orders may be given in any sequence and repeated as necessary, but the Judge shall attempt to standardize the heeling pattern for all dogs in any class.

The handler shall enter the ring with his/her dog on a loose leash and stand with the dog sitting in the Heel position. The judge shall ask if the handler is ready. The dog will be unleashed, and the leash given to the Judge. The Judge shall ask if the handler is ready before giving the order Forward. The handler may give a command or signal to Heel and walk briskly and in a natural manner with his/her dog. The dog shall walk close to the left side

of the handler without swinging wide, lagging, forging or crowding. Whether heeling or sitting, the dog must not interfere with the handler's freedom of motion at any time. At each order to Halt, the handler will stop after a few steps and his/her dog shall sit straight and promptly in the Heel position without command or signal and shall not move until the handler again moves forward on the Judge's order. It is permissible after each Halt, before moving again, for the handler to give a command or signal to Heel. The Judge shall say, "Exercise finished," after this portion of the exercise.

Before starting the Figure Eight the Judge shall ask if the handler is ready. On specific orders from the Judge to Forward and Halt, the handler and dog, from a starting position about equidistant from the two pylons and facing the Judge, shall walk briskly twice completely around and between the two pylons placed 8 feet apart. The handler may choose to go in either direction. There shall be no About Turn or Fast or Slow in the Figure Eight, but the Judge must order at least one Halt during and another Halt at the end of this portion of the exercise.

The Judge shall discretely accompany the handler to observe any signals or commands given by the handler to the dog. The Judge must do so without interfering with either dog or handler.

Section 4. Heel Free and Figure Eight Scoring

Major deductions	Substantial deductions	Minor deductions
<ul style="list-style-type: none"> Unqualified heeling 	<ul style="list-style-type: none"> Handler continually adapts pace to dog Constant guiding Extra command to heel or sit No change of pace including fast and slow No sits or poor sits 	<ul style="list-style-type: none"> Improper heel position Forging or crowding handler Lagging or sniffing Heeling wide including turns and abouts Lack of naturalness or smoothness Handler error

Section 5. Drop on Recall

The principal features of this exercise are that the dog stays where left until called by its handler, that it responds promptly to the handler's command or signal to Come and to Drop and remains in the Down position until again called or signaled to Come. The dog will be judged on the promptness of its response to command or signal and not on its proximity to a designated point.

Orders for the exercise are Leave your dog, Call your dog, a signal to Drop the dog, another Call your dog and

Finish. The Judge's signal must be clear to the handler but not obvious or distracting to the dog. The Judge will position himself behind the dog, facing the handler. On the Judge's order, the handler may give command and/or signal for the dog to Stay in the Sit position while the handler walks forward about 35 feet to the other end of the ring, where he shall turn and stand in a natural manner (upright, arms at sides) facing his/her dog. On Judge's order or signal, the handler shall give command or signal to Come and the dog must start directly in at a brisk trot or gallop. On the Judge's arm or hand signal, the handler shall give command or signal to Drop, and the dog must immediately drop completely to the Down position, where he must remain until, on Judge's order or signal, the handler again gives command or signal to Come. Once commanded to Come, the dog must come directly in at a brisk trot or gallop and Sit straight, centered immediately in front of the handler's feet, close enough that the handler could readily touch its head without moving either foot or having to stretch forward. The dog must not touch the handler or sit between his/her feet. On Judge's order the handler will give command or signal to Finish and the dog must go smartly to the Heel position and Sit. The manner in which the dog finishes shall be optional with the handler provided that it is prompt and that the dog sits straight at Heel.

Section 6. Drop on Recall Scoring

Major deductions	Substantial deductions	Minor deductions
<ul style="list-style-type: none"> Dog does not come on first command or signal after drop Dog does not drop on first command or signal 	<ul style="list-style-type: none"> Extra command or signal to stay after handler leaves Dog moved from place left Dog anticipated drop, recall or come in Dog sat out of reach 	<ul style="list-style-type: none"> Dog stood or downs Extra command or signal before leaving Dog touched handler Slow response or sat between feet Slow return or drop No sit or poor sit No finish or poor finish Lack of naturalness or smoothness Handler error

Section 7. Retrieve on Flat

The purpose of this exercise is to show that the dog can retrieve promptly. Orders are Throw it, Send your dog, Take it and Finish.

The handler will stand with his/her dog sitting in the heel position in a place designated by the Judge. On the Judge's order, Throw it, the handler will give the

command and/or signal to stay. If the handler does use a signal, that signal may not be given with the hand that is holding the dumbbell. After the dumbbell is thrown at least 20 feet, the Judge will order the handler, Send your dog. The retrieve should be executed at a brisk trot or gallop. The dog will go directly to the dumbbell and retrieve it, returning directly to the handler as in the Novice Recall without unnecessary mouthing or playing. On order from the Judge to Take it, the handler will give command or signal and take the dumbbell. The finish will be executed as in the Novice Recall.

The Judge will require the dumbbell to be thrown again before the dog is sent if it is thrown less than 20 feet, too far to one side, or too close to the ring's edge.

Section 8. Retrieve on Flat Scoring

Major deductions	Substantial deductions	Minor deductions
<ul style="list-style-type: none"> • Dog fails to go out on first command or signal • Dog fails to retrieve 	<ul style="list-style-type: none"> • Dog goes before command or signal • Dog does not go directly to dumbbell • Extra signal or command • Out of position stay 	<ul style="list-style-type: none"> • Slow to obey • Dog mouths or plays with dumbbell • Dog drops dumbbell • Dog fails to release dumbbell • Dog touches handler • Dog sits between feet • No sit or poor sit • No finish or poor finish • Handler error

Section 9. Retrieve Over High Jump

The purpose of this exercise is for the dog to go out over the jump, pick up the dumbbell and promptly return with it over the jump. The Judge's orders are Throw it, Send your dog, Take it and Finish. This exercise will be executed in the same manner as the Retrieve on Flat, except that the dog will clear the high jump both going and coming. The handler will stand at least 8 feet, or any reasonable distance beyond 8 feet, from the jump, will remain in the same spot throughout the exercise and will throw the dumbbell at least 8 feet beyond the jump. (These 8-foot distances should be clearly marked.)

Refer to the Graduate Novice Recall Over High Jump for jump height information.

Section 10. Retrieve Over High Jump Scoring

Major deductions	Substantial deductions	Minor deductions
<ul style="list-style-type: none"> • Goes to wrong jump • Uses jump as aid or climbing jump • Dog fails to go out on 1st command or signal • No jump on return 	<ul style="list-style-type: none"> • Dog goes before command or signal • Dog does not go directly to dumbbell • Extra signal or command • Out of position stay 	<ul style="list-style-type: none"> • Holding hand signals • Slow response • Hesitation or reluctance in jumping • Touching jump • No sit or poor sit • No finish or poor finish • Dog sat between feet • Touched handler • Handler error

Section 11. Broad Jump

The principal features of this exercise are the dog staying where left until directed to jump and the dog clears the jump on a single command or signal. Orders are Leave your dog, Send your dog and Finish. The handler will stand with his/her dog sitting in the Heel position in front of and at least 8 feet from the jump. On the Judge's order of Leave your dog, the handler will give his/her dog the command and/or signal to Stay and go to a position facing the right side of the jump. He will stand with his/her toes about 2 feet from the jump, and anywhere between the lowest edge of the first hurdle and the highest edge of the last hurdle.

On the Judge's order the handler shall give the command or signal to jump and the dog shall clear the entire distance of the Broad Jump without touching and, without further command or signal, immediately return to a sitting position in front of the handler. The handler shall change his/her position by executing a right-angle turn while the dog is in midair but shall remain in the same spot. The dog must come to the handler, stop directly in front of the handler, and Sit. The Finish command will be given, and the dog should return to the Heel position.

The Broad Jump consists of four hurdles made of boards about 8 inches wide. The largest measures about 5 feet in length and 6 inches high at the highest point; all are painted a flat white. When set up they shall be arranged in order of size and shall be evenly spaced. They will cover a distance equal to twice the height of the High Jump as set for the particular dog. The low side of each hurdle and the lowest hurdle will be set nearest the dog. Four hurdles shall be used for a jump of 48 inches to 72 inches, three for 28 inches to 44 inches, two for a jump of 16 inches to 24 inches, or one for a jump of 6 inches to 8 inches. When decreasing the number of boards in the jump, the highest hurdle shall be removed first. It is the Judge's responsibility to see that the distance jumped is that

required by these Guidelines for the particular dog.

Section 12. Broad Jump Scoring

Major deductions	Substantial deductions	Minor deductions
<ul style="list-style-type: none"> • Dog walks over any part of jump • Dog does not jump on first command or signal 	<ul style="list-style-type: none"> • Goes before command or signal • Does not clear jump • Sat out of reach • Out of position stay 	<ul style="list-style-type: none"> • Slow response • Dog touches handler • Minor jump touch • Hesitation to jump • Poor return • Dog sits between feet • No sit or poor sit • No finish or poor finish • Handler error

Section 13. Long Sit and Down (Group Exercises)

During the Long Sit and the Long Down exercises the Judge shall stand so all the dogs and handlers are in his/her line of vision at all times. Class size will be no less than two dogs and no more than 12. For a single dog, an on-leash dog/handler may be added for companionship.

After leaving their dogs, the handlers will give a command and/or signal to stay and immediately proceed to the end of the 6 foot leash and turn to face the dog.

On the Judge's order, the handlers shall return to their dogs, returning to them on the Judge's order. The Judge shall not give the order, Exercise finished, until the handlers have returned to the Heel position.

Section 14. Group Exercise Scoring

During these exercises the Judge shall stand so that all of the dogs are in his/her line of vision, as well as the handlers in the ring, or leaving and returning to the ring, without having to turn around. Scoring of the exercises will not start until after the Judge has ordered the handlers to leave their dogs, except for such things as rough treatment of a dog by its handler or resistance by a dog to its handler's attempts to make it Sit or lie down.

A handler whose dog assumes a position in such a manner that it could interfere with an adjacent competing dog shall be required to reposition his/her dog and shall also be substantially penalized; in extreme cases the dog may be excused with a white ribbon.

Major deductions	Substantial deductions	Minor deductions
<ul style="list-style-type: none"> • Stood, sat or downs within 15 seconds (sit stay) or within 1 minute (down stay) 	<ul style="list-style-type: none"> • Repeated whines or barks • Forcing into position • Out of position stay • Stood, sat or downs within 15-90 seconds (sit stay) or 15 seconds to 3 minutes (down stay) 	<ul style="list-style-type: none"> • Minor move before handler returns • Minor whine or bark • Excessively loud commands • Handler error • Stood, sat or downs within 90 seconds to 3 minutes (sit stay) or 3-5 minutes (down stay)

Chapter 8: Graduate Open

Section 1. Graduate Open Class

The Graduate Open class is for a handler and dog that have received a purple at the State 4-H Dog Show in Open. Teams may move up to Graduate Open regardless of County or State ribbon placing.

Section 2. Graduate Open Exercises and Scoring

All exercises will be performed Off Leash

Graduate Open Exercises	Points
Signal Exercise	40
Scent Discrimination	30
Directed Retrieve	30
Moving Stand and Exam	30
Go Out	30
Directed Jumping	40

Section 3. Signal Exercise

The principal features of this exercise are the ability of dog and handler to work as a team while heeling, and the dog's correct responses to the signals to Stand, Stay, Drop, Sit and Come. Orders are the same as in Heel on Leash and Figure Eight, with the additions of Stand your dog, which shall be given only when dog and handler are walking at normal pace and Leave your dog. The Judge must use signals for directing the handler to signal the dog to Drop, to Sit and to Come, in that sequence, and to Finish.

Heeling in the Signal Exercise shall be done in the same manner as in Heel Free, except that throughout the entire exercise the handler shall use signals only and must not speak to his/her dog at any time. The Judge's order of, Forward, the handler may signal his/her dog to walk at heel, and on specific order from the Judge in each case, shall execute a Left turn, Right turn, About turn, Halt, Slow, Normal and Fast. Fast signifies the handler must run with handler and dog moving forward at noticeably

accelerated speed. These orders may be given in any sequence and may be repeated as necessary, but the Judge shall attempt to standardize the heeling pattern for all dogs in the class.

On the Judge's order, and while the dog is walking at heel, the handler shall signal his/her dog to Stand in the Heel position near one end of the ring. On further order to Leave your dog, the handler shall signal his/her dog to Stay, go to the other end of the ring and turn to face his/her dog. On separate and specific signals from the Judge, the handler shall give his/her dog signals to Drop, to Sit and to Come.

On Judge's order the handler will give command or signal to Finish and the dog must go smartly to the Heel position and Sit. The manner in which the dog finishes shall be optional with the handler provided that it is prompt and that the dog Sit straight at Heel. During the heeling part of this exercise the handler may not give any signal except when a command or signal is permitted in the Heeling exercises.

Section 4. Signal Exercise Scoring

Major deductions	Substantial deductions	Minor deductions
<ul style="list-style-type: none"> Unqualified heeling 	<ul style="list-style-type: none"> Handler adapts pace to dog Any audible command Failure on 1st signal to: Stand, Stay, Drop, Sit or Come Anticipated command to: Stand, Stay, Drop, Sit or Come Sat out of reach 	<ul style="list-style-type: none"> Forging or crowding handler Lagging or sniffing Heeling wide Holding signals Slow response to signal, stand, down, sit or come No change of pace Extra command to heel or finish Poor sits Touching handler Sat between feet Poor finish or no finish Handler error

Section 5. Scent Discrimination

The principal features of these exercises are the selection of the handler's article from among the other articles by scent alone, and the prompt delivery of the right article to the handler. The Judge will ask, "Are you ready?" immediately prior to taking the article from the handler. Taking of the article from the handler will be considered the first order, and scoring of the exercise will begin at that time. The remaining orders are Send your dog, Take It and Finish. In each of these two exercises the dog

must select by scent alone and retrieve an article, which has been handled by its handler. The articles shall be provided by the handler and consist of two sets; each comprised of five identical objects not more than 6 inches in length, which may be items of everyday use. To comprise the two sets, handlers shall pick any two of the three following option types—set made entirely of rigid metal, set made entirely of rigid wood, set made of leather design such that nothing but leather is visible except for the minimum amount of thread or metal necessary to hold the object together. The articles in each set must be legibly numbered, each with a different number, and must be approved by the Judge.

The handler shall present all 10 articles to the Judge, who shall designate one from each set and make a written note of the numbers of the two articles he has selected. These two handler's articles shall be placed on a table or chair within the ring until picked up by the handler, who shall hold in his hand only one article at a time. The Judge or Steward will handle each of the remaining eight articles as s/he places them on the floor or ground at random and about 6 inches apart, with the closest article being about 20 feet from the handler and the dog. Before the dog is sent, the Judge must make sure that the articles are visible to the dog and handler, and that the articles are properly separated so that there will be no confusion of scent between the articles.

Handler and dog shall turn around after watching the Judge or Steward spread the articles and remain facing away from the articles until the Judge has taken the handler's scented article and given the order, "Send your dog." The handler may use either article first but must return each immediately when ordered by the Judge. The Judge shall make certain that the handler imparts his scent to each article only with his hands. The article must remain in plain sight, and in the handler's hands. On the Judge's order, the handler will immediately place his article on the Judge's book or work sheet. The Judge, without touching the article, will place it among those on the ground or floor.

On the Judge's order, Send your dog, the handler may give the command to heel and will turn in place, right or left, to face the articles. The handler will come to a halt with the dog sitting in the heel position. The handler shall then give the command or signal to retrieve. Handlers may, at their discretion, on the Judge's order of Send your dog, execute with their dog a right about turn to face the articles, simultaneously giving the command or signal to Retrieve. In this instance the dog shall not assume sitting position but go directly to the articles. The handler may give his scent to the dog by gently touching the dog's

nose with the palm of one open hand. This may only be done while the dog and handler have their backs to the articles and the arm and hand must be returned to a natural position before handler and dog turn to face the articles.

The dog shall go at a brisk trot or gallop directly to the articles. It may take any reasonable time to select the right article, but only provided it works continuously. After picking up the right article the dog shall return at a brisk trot or gallop and complete the exercise as in the Retrieve on the Flat. These procedures shall be followed for both articles. If a dog retrieves a wrong article in the first exercise, that article shall be placed on the table or chair. The correct article must be removed, and the second exercise shall be conducted with one less article on the ground or floor.

Section 6. Scent Discrimination Scoring

Major deductions	Substantial deductions	Minor deductions
<ul style="list-style-type: none"> Unqualified heeling No retrieve 	<ul style="list-style-type: none"> Does not go out on first command Wrong article Extra command Anticipated Sat out of reach 	<ul style="list-style-type: none"> Doesn't work continuously Dropping article on return Picked up wrong article then dropped No sit in front Sat after turn Mouthing Touching handler Slow response Sat between feet Poor finish or no finish Handler error

Section 7. Directed Retrieve

The principal features of this exercise are that the dog stay until directed to retrieve and that it go directly to the designated glove and retrieve it promptly. The handler will provide two gloves that are predominately white. They must be open and must be approved by the Judge. Handlers will stand with their backs to the unobstructed end of the ring midway between and in line with the jumps. The dog will be sitting in heel position. The Judge or steward will drop the gloves across the end of the ring while the handler and dog are facing the opposite direction. One glove is dropped about 3 feet in from each corner.

The gloves will be designated One, and Two, reading from left to right when the handler is facing the gloves. The orders for the exercise are: One, or Two, Take it and Finish. When the Judge designates the glove by number, the handler will turn in place to face the glove, halting

with the dog sitting in heel position. The handler may not touch the dog or reposition it. The handler will give the dog the direction to the designated glove with a single motion of the left hand and arm along the right side of the dog. Either simultaneously with or immediately following giving the direction, the handler must give a verbal retrieve command. The dog must then go directly to the glove, completing the exercise as in the Retrieve on Flat.

Handlers may bend their bodies and knees as far as necessary to give the direction to the dogs but must then stand up in a natural position with their arms at their sides. The Judge will designate the same glove number for each handler.

Section 8. Directed Retrieve Scoring

Major deductions	Substantial deductions	Minor deductions
<ul style="list-style-type: none"> Does not go out on first command Does not retrieve right article Fails to retrieve Does not go directly to glove 	<ul style="list-style-type: none"> Anticipated Sat out of reach Extra signal or command 	<ul style="list-style-type: none"> Touching dog when sending Slow response to commands Dropping article Mouthing or playing Poor delivery No sit in front Touching handler Poor sit No finish or poor finish Handler error

Section 9. Moving Stand and Examination

The principal features of the exercise are that the dog heel, stand and stay on command by the moving handler, accept the examination without shyness or resentment, and return to the handler on command. The orders for the exercise are Forward, Stand your dog, both given while the handler is walking, and Call your dog to heel.

The handler stands with his/her dog sitting in the heel position at a point indicated by the Judge. The Judge asks, "Are you ready?" and orders, "Forward." The handler commands or signals his/her dog to heel and walks briskly at a normal pace. After the handler has proceeded about 10 feet the Judge orders, "Stand your dog." The handler will, without pausing, command and/or signal the dog to stand, continue forward 10-12 feet and turn around, either to the right or left, and stand facing the dog. The dog must stand and stay in position.

The Judge approaches the dog from the front and examines it by going over it with his/her hands as in dog show judging except that in no circumstances shall the examination include the dog's mouth or testicles.

The Judge then orders, "Call your dog to heel," whereupon the handler commands and/or signals the dog to return to the heel position. The dog immediately returns in a brisk manner to the proper heel position beside the handler.

Section 10. Moving Stand and Examination Scoring

Major deductions	Substantial deductions	Minor deductions
<ul style="list-style-type: none"> Sat or downs 	<ul style="list-style-type: none"> Repeated whining or barking Failure to heel, stand and stay, accept examination or return to handler Extra command or signals Dog moves during exam Dog anticipates Dog repeatedly barks or whines 	<ul style="list-style-type: none"> Forging or lagging Wide Moves slightly on stand Handler hesitates or pauses Fails to return briskly Poor sit or return to heel position Slow response Handler error Poor finish Handler error

Section 11. Go Out

The purpose of this exercise is for the dog to go away from the handler to the opposite end of the ring and stop as directed. The Judge's orders are Send your dog and Return to your Dog.

The handler will stand in the approximate center of the ring between the jumps facing the unobstructed end of the ring. The Judge will order Send your dog, and the handler will command and/or signal the dog to go forward at a brisk trot or gallop to a point about 20 feet past the jumps in the approximate center of the ring. When the dog reaches this point, the handler will give a command to sit.

The dog must stop and sit with its attention on the handler, but it need not sit squarely.

The Judge will then order the handler, "Return to your dog," and the handler will return to the heel position.

Section 12. Go Out Scoring

Major deductions	Substantial deductions	Minor deductions
<ul style="list-style-type: none"> Does not leave on order 	<ul style="list-style-type: none"> Does not stop on command Does not go at least 10 feet beyond jumps Second command to sit 	<ul style="list-style-type: none"> Slightly off direction Anticipated turn, stop or sat Not back far enough Doesn't sit on command Handler error

Section 13. Directed Jumping

The principal features of this exercise are that the dog stays where left, jumps as directed and returns as in the Recall. The orders are Leave your dog, Bar or High, and Finish. The jumps shall be placed midway in the ring at right angles to the sides of the ring and 18 to 20 feet apart, the Bar Jump on one side, the High Jump on the other. The Judge must make certain that the jumps are set at the required height for each dog by following the procedure described in Retrieve over the High Jump.

The handler will stand with the dog sitting in the heel position at the unobstructed end and in the center of the ring. On the Judge's order he will walk to the far end of the ring and turn to face the dog. The Judge will designate which jump is to be taken first by the dog and shall order either High or Bar, when designating either the High or Bar Jump. The handler shall command and/or signal the dog to return to him over the designated jump. While the dog is in midair the handler may turn so as to be facing the dog as it returns. The dog shall sit in front of the handler and, on the Judge's order, "Finish" as in the Novice Recall. The Judge will say, "Exercise finished," after the dog has returned to the Heel position. The dog will be sent over only one jump, and the same jump will be used for all dogs as designated by the judge at the start of the class.

The height of the jumps shall be the same as required in the Graduate Novice classes. The High Jump shall be the same as that used in the Graduate Novice classes, and the Bar Jump shall consist of a bar between 2 and 2½ inches square with the four edges rounded sufficiently to remove any sharpness. The bar shall be painted a flat black and white in alternate sections of about 3 inches each. Two unconnected 4-foot upright posts about 5 feet apart shall support the bar. The bar shall be adjustable for each 2 inches of height from 4 inches to 36 inches, and the jump shall be so constructed and positioned that the bar can be knocked off without disturbing the uprights.

Section 14. Directed Jumping, Scoring

Major deductions	Substantial deductions	Minor deductions
<ul style="list-style-type: none"> Dog does not leave on order or stop on command Goes to wrong jump 	<ul style="list-style-type: none"> Dog does not go at least 10 feet beyond the jumps Dog climbs jump or knocks bar off Dog anticipates command 	<ul style="list-style-type: none"> Holding signals Slow response to directions Dog doesn't go back far enough Handler error Dog is hesitant or reluctant to jump Does not sit on command Anticipated turn, stops or sits No sit in front Touches handler Sat between feet Poor sits Anticipates finish No finish or poor finish Handler error

Chapter 9: Utility

Section 1. Utility Class.

The Utility class is for handler and dog that have received a purple at the State 4-H Dog Show in Graduate Open. Teams may move up to Utility regardless of County or State ribbon placing.

Section 2. Utility Exercises and Scoring

Exercise	Points
Signal Exercise	40
Scent Discrimination – Article 1	30
Scent Discrimination – Article 2	30
Directed Retrieve	30
Moving Stand and Examination	30
Directed Jumping	40
Maximum Total Score	200

Section 3. Signal Exercise

The principal features of this exercise are the ability of dog and handler to work as a team while heeling, and the dog's correct responses to the signals to Stand, Stay, Drop, Sit and Come. Orders are the same as in Heel on Leash and Figure Eight, with the additions of Stand your dog, which shall be given only when dog and handler are walking at normal pace and Leave your dog. The Judge must use signals for directing the handler to signal the dog to Drop, Sit and Come, in that sequence, and to Finish.

Heeling in the Signal Exercise shall be done in the same manner as in Heel Free, except that throughout the entire exercise the handler shall use signals only and must not speak to his/her dog at any time. At the Judge's order of

“Forward,” the handler may signal his/her dog to walk at heel, and on specific order from the Judge in each case, shall execute a Left turn, Right turn, About turn, Halt, Slow, Normal and Fast. Fast signifies the handler must run with handler and dog moving forward at noticeably accelerated speed. These orders may be given in any sequence and may be repeated as necessary, but the Judge shall attempt to standardize the heeling pattern for all dogs in the class.

On the Judge's order, and while the dog is walking at heel, the handler shall signal his/her dog to Stand in the Heel position near one end of the ring. On further order to Leave your dog, the handler shall signal his/her dog to Stay, go to the other end of the ring and turn to face his/her dog. On separate and specific signals from the Judge, the handler shall give his/her signals to Drop, to Sit and to Come. On Judge's order the handler will give command or signal to Finish and the dog must go smartly to the Heel position and Sit. The manner in which the dog finishes shall be optional with the handler provided that it is prompt and that the dog Sit straight at Heel. During the heeling part of this exercise the handler may not give any signal except when a command or signal is permitted in the Heeling exercises.

Section 4. Signal Exercise Scoring

Major deductions	Substantial deductions	Minor deductions
<ul style="list-style-type: none"> Unqualified heeling 	<ul style="list-style-type: none"> Handler adapts pace to dog Any audible command Failure on 1st signal to: Stand, Stay, Drop, Sit or Come Anticipated command to: Stand, Stay, Drop, Sit or Come Sat out of reach 	<ul style="list-style-type: none"> No change of pace Heeling wide Forging or crowding handler Lagging or sniffing Holding signals Poor sits Slow response to signal, stand, down, sit or come Sat between feet Touching handler Poor finish or no finish Handler error

Section 5. Scent Discrimination

The principal features of these exercises are the selection of the handler's article from among the other articles by scent alone, and the prompt delivery of the right article to the handler. The judge asks, “What method are you using to send your dog?” The handler must respond with either “After a sit” or “Send directly.” The Judge will ask, “Are you ready?” immediately prior to taking the article from

the handler. The taking of the article from the handler will be considered to be the first order and scoring of the exercise will begin at that time. The remaining orders are Send your dog, Take It and Finish. In each of these two exercises the dog must select by scent alone and retrieve an article that has been handled by its handler. The articles shall be provided by the handler and shall consist of two sets; each comprised of five identical objects not more than 6 inches in length, which may be items of everyday use. One set shall be made entirely of rigid metal, and one of leather of such design that nothing but leather is visible except for the minimum amount of thread or metal necessary to hold the object together. The articles in each set must be legibly numbered, each with a different number, and must be approved by the Judge.

The handler shall present all 10 articles to the Judge, who shall designate one from each set and make a written note of the numbers of the two articles s/he has selected. These two handler's articles shall be placed on a table or chair within the ring until picked up by the handler, who shall hold in his/her hand only one article at a time. The Judge or Steward will handle each of the remaining eight articles as he places them on the floor or ground at random and about 6 inches apart, with the closest article being about 20 feet from the handler and the dog. Before the dog is sent, the Judge must make sure that the articles are visible to the dog and handler, and that the articles are properly separated so that there will be no confusion of scent between the articles.

Handler and dog shall turn around after watching the Judge or Steward spread the articles and shall remain facing away from those articles until the Judge has taken the handler's scented article and given the order, "Send your dog." The handler may use either article first but must relinquish each one immediately when ordered by the Judge. The Judge shall make certain that the handler imparts his/her scent to each article only with his/her hands. Additionally, between the time the handler picks up each article and the time s/he gives it to the Judge, the article is held continuously in the handler's hands, which must remain in plain sight. On the Judge's order, the handler will immediately place his/her article on the Judge's book or work sheet. The Judge, without touching the article with his/her hands, will place it among those on the ground or floor.

On the Judge's order of Send your dog, the handler may give the command to heel and will turn in place, right or left, to face the articles. The handler will come to a halt with the dog sitting in the heel position. The handler shall then give the command or signal to retrieve. Handlers may, at their discretion, on the Judge's order of Send your

dog, execute with their dog a right about turn to face the articles, simultaneously giving the command or signal to retrieve. In this instance the dog shall not assume sitting position but shall go directly to the articles. The handler may give his/her scent to the dog by gently touching the dog's nose with the palm of one open hand. This may only be done while the dog and handler have their backs to the articles and the arm and hand must be returned to a natural position before handler and dog turn to face the articles.

The dog shall go at a brisk trot or gallop directly to the articles. It may take any reasonable time to select the right article, but only provided it works continuously. After picking up the right article the dog shall return at a brisk trot or gallop and complete the exercise as in the Retrieve on the Flat.

These procedures shall be followed for both articles. If a dog retrieves a wrong article in the first exercise, that article shall be placed on the table or chair. The correct article must be removed, and the second exercise shall be conducted with one less article on the ground or floor.

Section 6. Scent Discrimination Scoring

Major deductions	Substantial deductions	Minor deductions
<ul style="list-style-type: none"> No retrieve Wrong article 	<ul style="list-style-type: none"> Does not go out on first command Extra command Anticipated Sat out of reach 	<ul style="list-style-type: none"> Doesn't work continuously Dropping article on return Picked up wrong article then dropped No sit in front Sat after turn Mouthing Touching handler Slow response Sat between feet Poor finish or no finish Handler error

Section 7. Directed Retrieve

The principal features of the exercise are that the dog stays until directed to retrieve, that it goes directly to the designated glove, and that it retrieves promptly. The orders for the exercise are One, Two or Three, Take it and Finish. In this exercise the handler will provide three predominantly white, cotton work gloves, which must be open and must be approved by the Judge. The handler will stand with his/her back to the unobstructed end of the ring with his/her dog sitting in the Heel position midway between and in line with the two jumps. The Judge or Steward will drop the three gloves across the end of the ring, while the handler and dog are facing the

opposite direction. S/He will place one glove in each corner and one in the center, about 3 feet from the end of the ring, and for the corner gloves, about 3 feet from the side of the ring. All three gloves will be clearly visible to the dog and handler when the handler turns to face the glove designated by the Judge. There shall be no table or chair at this end of the ring. The gloves shall be designated One Two or Three reading from left to right when the handler turns and faces the gloves. The Judge will give the order One, or Two or Three. The handler then may give the command to Heel and turn in place, right or left to face the designated glove. The handler will come to a halt with the dog sitting in the Heel position. The handler shall not touch the dog to get it into position nor may s/he reposition the dog. The handler will then give his/her dog the direction to the designated glove with a single motion of his left hand and arm along the right side of the dog and will give a verbal command to retrieve either simultaneously with or immediately following the giving of the direction. The dog shall then go directly to the glove at a brisk trot or gallop and retrieve it without unnecessary mouthing or playing with it, completing the exercise as in the Retrieve on the Flat. The handler may bend his/her body and knees to the extent necessary in giving the direction to the dog, after which the handler will stand erect in a natural position with his/her arms at his/her sides.

The exercise shall consist of a single retrieve. Prior to the start of judging the Judge shall decide to either (a) assign the gloves to dogs so that successive dogs in catalog order will have different gloves, or (b) to assign the gloves as the dogs appear in the ring for judging so that two successive dogs do not retrieve the same glove. In either case each glove shall be used approximately the same number of times.

Section 8. Directed Retrieve Scoring

Major deductions	Substantial deductions	Minor deductions
<ul style="list-style-type: none"> Does not go out on first command Does not retrieve right article Fails to retrieve Does not go directly to glove 	<ul style="list-style-type: none"> Anticipated Sat out of reach Extra signal or command 	<ul style="list-style-type: none"> Touching dog when sending Slow response to commands Dropping article Mouthing or playing Poor delivery No sit in front Touching handler Poor sit No finish or poor finish Handler error

Section 9. Moving Stand and Examination

The principal features of the exercise are that the dog heel, stand and stay on command by the moving handler, accept the examination without shyness or resentment, and return to the handler on command. The orders for the exercise are Forward, Stand your dog, both given while the handler is walking, and Call your dog to heel.

The handler stands with his/her dog sitting in the heel position at a point indicated by the Judge. The Judge asks, "Are you ready?" and orders, "Forward." The handler commands or signals his/her dog to heel and walks briskly at a normal pace. After the handler has proceeded about 10 feet the Judge orders, "Stand your dog." The handler will, without pausing, command and/or signal the dog to stand, continue forward 10-12 feet and turn around, either to the right or left, and stand facing the dog. The dog must stand and stay in position.

The Judge approaches the dog from the front and examines it by going over it with his hands as in dog show judging except that in no circumstances shall the examination include the dog's mouth or testicles.

The Judge then orders, "Call you dog to heel," whereupon the handler commands and/or signals the dog to return to the heel position. The dog immediately returns in a brisk manner to the proper heel position beside the handler.

Section 10. Moving Stand and Examination Scoring

Major deductions	Substantial deductions	Minor deductions
<ul style="list-style-type: none"> Sat or downs 	<ul style="list-style-type: none"> Repeated whining or barking Failure to heel, stand and stay, accept examination or return to handler Extra command or signals Dog moves during exam Dog anticipates 	<ul style="list-style-type: none"> Forging or lagging Moves slightly on stand Handler hesitates or pauses Fails to return briskly Poor sit or return to heel position Slow response Handler error Poor finish

Section 11. Directed Jumping

The principal features of this exercise are that the dog goes away from the handler in the direction indicated, stops, jumps as directed and returns as in the Recall. The orders are Send your dog, Bar or High and Finish. The jumps shall be placed midway in the ring at right angles to the sides of the ring and 18 to 20 feet apart, the Bar Jump on one side, the High Jump on the other. The Judge must make certain that the jumps are set at the

required height for each dog by following the procedure described in Retrieve over the High Jump.

The handler, from a position on the centerline of the ring and about 20 feet from the line of the jumps, shall stand with his/her dog sitting in the Heel position. On the Judge's order s/he shall command and/or signal his/her dog to go forward at a brisk trot or gallop to a point about 20 feet beyond the jumps and in the approximate center of the unobstructed end of the ring. When the dog has reached this point the handler shall give a command to Sit; the dog must stop and sit with his/her attention on the handler but need not sit squarely.

The Judge will designate which jump is to be taken first by the dog and shall order either High or Bar, when designating either the High or Bar Jump. The handler shall command and/or signal the dog to return to him over the designated jump. While the dog is in midair the handler may turn so as to be facing the dog as it returns. The dog shall sit in front of the handler and, On the Judge's order, "Finish" as in the Novice Recall. The Judge will say, "Exercise finished," after the dog has returned to the Heel position. When the dog is again sitting in the Heel position the Judge shall ask, Are you ready? before giving the order to send the dog for the second part of the exercise. The same procedure shall be followed for the second jump.

The Judge will choose which jump is taken first, but both jumps must be taken to complete the exercise and the Judge must not designate the jump until the dog is at the far end of the ring. The dog shall clear the jumps without touching them.

The height of the jumps shall be the same as required in the Open classes. The High Jump shall be the same as that used in the Open classes, and the Bar Jump shall consist of a bar between 2 and 2 1/2 inches square with the four edges rounded sufficiently to remove any sharpness. The bar shall be painted a flat black and white in alternate sections of about 3 inches each. Two unconnected 4-foot upright posts about 5 feet apart shall support the bar. The bar shall be adjustable for each 2 inches of height from 4 inches to 36 inches, and the jump shall be so constructed and positioned that the bar can be knocked off without disturbing the uprights.

Section 12. Directed Jumping, Scoring

Major deductions	Substantial deductions	Minor deductions
<ul style="list-style-type: none"> Goes to wrong jump Dog climbs jump or knocks bar off 	<ul style="list-style-type: none"> Dog does not leave on order, stop on command or jump as directed Dog does not go at least 10 feet beyond the jumps Dog anticipates command 	<ul style="list-style-type: none"> Holding signals Slow response to directions Dog doesn't go back far enough Handler error Dog is hesitant or reluctant to jump Does not sit on command Anticipated turn, stops or sits No sit in front Touches handler Sat between feet Poor sits Anticipates finish No finish or poor finish

Chapter 10: Brace

Section 1. Brace Class

This class is for two dogs working in unison at all times. Dogs need not be alike in size, markings, or sex, to be a Brace. Dogs do not have to be owned by the same person, but must be handled by one person, and be under the direct care and management of the 4-H'er for a minimum of two months, as stated in Chapter 1.

Dogs may be shown unattached or coupled. The Coupler device must be at least 6 inches in overall length. Whichever method used must be continued throughout all exercises. Collars and leashes used for this class are listed in the General Guidelines for Pre-Novice and higher levels of Obedience. It is recommended the dogs wear the same type of collar when performing Brace. If choke chain collars are used, the inside dog's collar should be put on "upside down," due to the leash attachment being on the left side of the dog. This placement ensures the collar releases after any tightening of the leash/collar combination. Placing the faster of the two dogs on the outside of the two dogs helps to prevent lagging in heeling and turns.

Available level for Brace is Novice. The same score sheets used in individual performances are used for Brace. If the dogs are in different Obedience levels, they compete in the highest level. One handler only is allowed for the same two dogs performing this class. If one of the dogs is needed for another Brace, this can be done, if handled by another 4-H'er. The dogs are judged together as one, for a maximum of 200 points.

Commands for the dogs are given as one command, to both dogs at one time.

The dogs' names can be said individually, such as "Snickers/Lucy-Stay," or as a pair, "Girls-Stay". Whichever way the commands are given, this should stay consistent throughout all exercises. The hand signal is given as one movement across the faces of both dogs. The exception is for the Stand for Examination exercise. The dogs can be individually posed with their name and command to "Stand," or as one command, as in the "Stay" commands. After each dog is stood, and position checked, the Handler should stand up, give one "Stay" command, and step away from the dogs. On the Recall exercise, dogs are called together as one, "Snickers/Lucy-Come." The Finish command is given once, for both dogs to finish as one, either around or next to the handler. A right finish is generally recommended for the Brace.

Chapter 11: Team

Section 1. Team Class

The Team class is for teams of any four dogs and handlers that are eligible under these guidelines. Dogs do not have to be the same breed, size, coloration or sex. Handlers and dogs can be from different counties but must be competing at the same level. If the option is available and enough dogs are available from a county, a team of larger dogs, and one of smaller dogs should be considered. This is not a requirement, but just adds additional uniformity. Team members are recommended to wear the same type of clothing and shoes, again to keep as uniform as possible. Also, it is recommended to have matching leashes and similar collars, but this IS NOT a requirement for Team. The Team consists of four handlers—one being the Captain. The Captain sets the pace for heeling, and when to start an exercise. The Captain can be either on the left or right side of the Team. Other Team members should always be aware of the Captain's position and lineup accordingly with this individual. Spacing of the dogs is done by measuring an arm's length between the members. Placing the 4-Her's hand on the next one's shoulder at the beginning, when the team is setting up, ensures correct spacing between dogs and handlers. When starting to practice for Team, it is recommended to practice without the dogs, to ensure that members are comfortable marching together and can work on foot work and spacing more easily. Team requires more practice for the handlers than the dogs!

There shall be two judges, one of whom will call commands while the other scores the team's performance. The Teams will be judged one at a time, except for the Long Sit and Long Down exercises, which shall be done with no more than four teams (16 dogs) in the ring.

The dogs on a team will perform the exercises simultaneously and will be judged as specified for the Novice class. The age level the team is judged is determined by the oldest handler on the team. Five dogs can be entered, with one dog/handler considered an alternate. If the alternate is required at the county show level, the dog/handler replaced, will become the alternate, if the team qualifies for the state level. In all exercises, the teams have the option of executing the Judge's commands on the Team Captain's repeat of the command. In the Figure Eight portion of the Heel on Leash exercise, five Stewards will be used. The Stewards shall stand 8 feet apart in a straight line. One handler, with dog sitting in Heel position, shall stand about equidistant from each of two Stewards, all members of the team facing in the same direction. On orders from the Judge, the Team shall perform the Figure Eight, each handler starting around the Steward on his/her left and circling only the two stewards between whom s/he had been standing. It is very important to time the Come command to be called at the same time. Even though the dogs all have different names, if the word "Come" is said at the same time, this greatly improves the dogs returning to their handler. The Finish shall be done in unison on the command from the Judge.

Section 2. Team Class Scoring

Scoring of the Team class shall be based on the performance of the dogs and handlers individually plus team precision and coordination. Each dog and handler will be scored against the customary maximum for a team total of 800 maximum available points. Individual dog's scores shall be recorded; a specific score sheet is available for Team scoring.

Glossary of Terms

(Taken from AKC Obedience and Rally* Regulations)

Brisk, briskly – keenly alive, alert, energetic

Command – verbal order from handler to dog

Crooked – a dog that is not straight in line with the direction the handler is facing

Crowding – a dog so close to handler as to interfere with handler's freedom of motion

Directly – immediately, without deviation or hesitation

Drop completely – a down position that would be acceptable for a Long Down exercise

Forging – to move forward or ahead steadily, but in a gradual fashion

Gently – with kindness, without harshness or roughness

Guiding gently by the collar – control of the dog by holding any part of the collar with minimal pressure on the dog's neck

Handler – one who holds and incites a dog during a match

Lagging – to walk or move slowly, to fall behind

Lame – irregularity or impairment of the function of locomotion, irrespective of the cause or how slight or severe

Maximum penalty – all points lost or Non-Qualifying zero. In 4-H, a Maximum Point Deduction means that at least one-half of the total points for that exercise will be deducted if the youth/dog team fails to perform one part of that exercise.

Minor penalty – 1 point to 2 points per fault or error

Mouthing – when a dog chews or rolls the dumbbell in its mouth unnecessarily

Natural Manner – not artificial; free of affectation; what is customarily expected in the home or public places

Order – direction from Judge to handler, either verbal or nonverbal

Pause – a complete stop of forward motion by the handler

Pivot – turning in the circle occupied by the handler before they started the turn; a turn in place

Prompt Response – without hesitation, immediate, quick

Resentment – resistance, unwillingness

Signal – nonverbal direction from the handler to dog

Show Official – any person having official duties, volunteer or paid, during a particular show or event

Smartly – quickly, vigorously

Substantial penalty – 3 points or more per fault or error

Team – associated together, as those on one side in a match

Turn in place – turning in the circle that was occupied by the handler before they started to turn

Withers – highest point of the dog's shoulder

Jump Construction

Suggested construction of Broad Jump

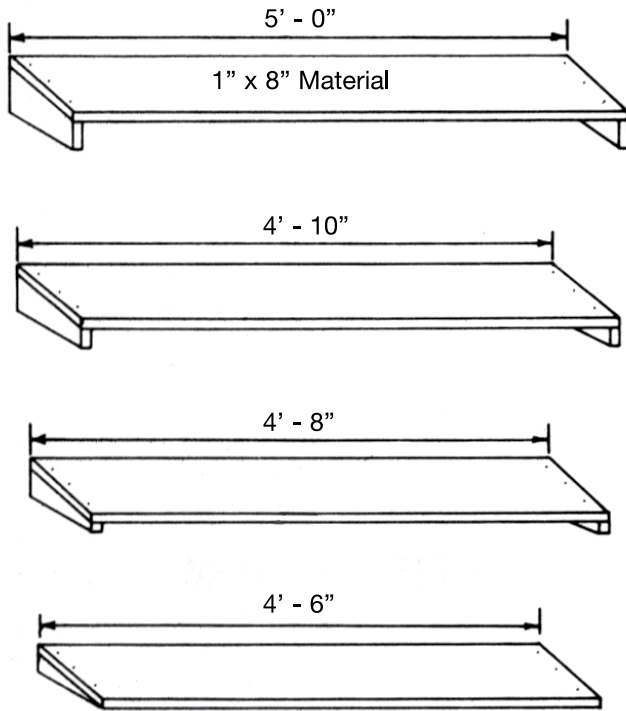

ELEVATION

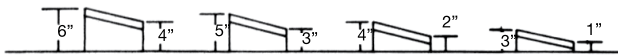

End view of four hurdles

This jump must be painted a flat white.

NOTE: The lowest height for either the high or bar jump is now 4 inches.

SUGGESTED CONSTRUCTION OF HIGH JUMP

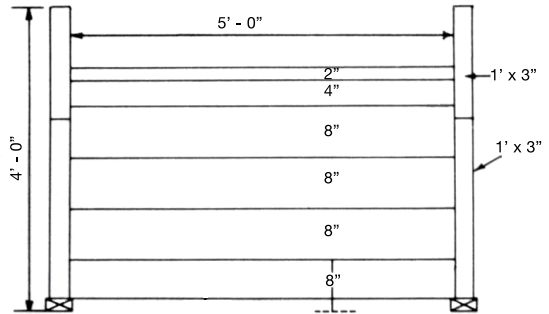

These boards are removable

FRONT VIEW

top view of groove

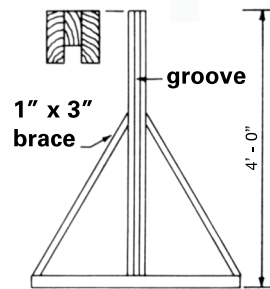

This upright consists of two pieces 1" x 3" and one piece 1" x 2", nailed together, with the 1" x 2" forming the groove for the boards to slide in.

SIDE VIEW

The high jump must be painted a flat white.

Jump Construction

Suggested construction of Bar Jump

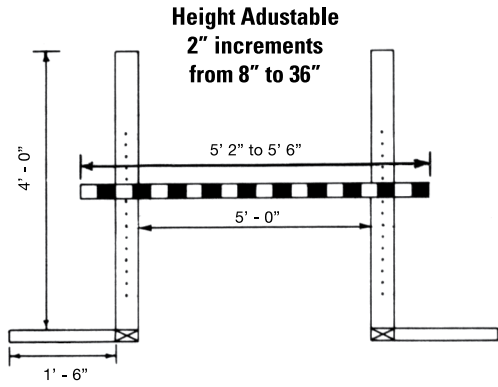

FRONT VIEW

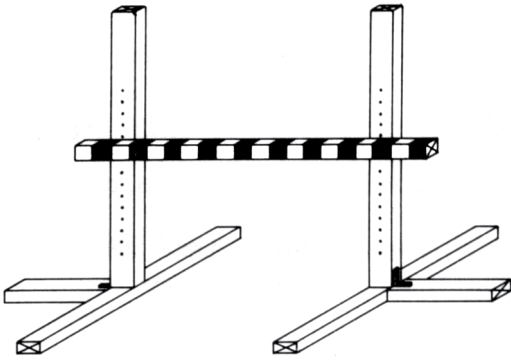

ELEVATION

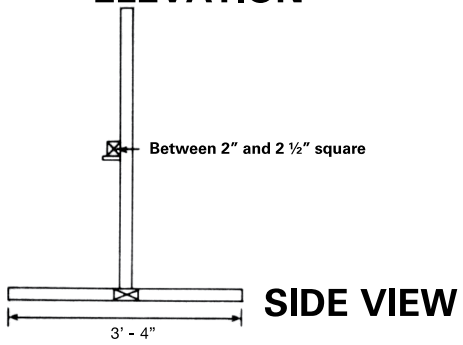

SIDE VIEW

Section 3

Dog Rally

Dog Rally

Introduction

Rally, like other 4-H Dog activities, is a sport in which all participants should be guided by the principles of good sportsmanship both inside and outside the ring. Rally trials demonstrate the usefulness of the dog as a companion of mankind, not merely the dog's ability to follow specified routines in the ring. All participants in the rally classes are required to perform the same exercises in substantially the same way so that the quality of the various performances may be compared and scored. The basic objective of Rally is to provide an activity that does not require extensive precision for success. Dogs who participate in Rally are dogs that have been trained and conditioned to behave in the home, in public places and in the presence of other dogs. Dogs in rally events should demonstrate willingness and enjoyment. To that end, handlers may use encouragement, praise and body language throughout the rally course.

Rally is a sport in which the dog and handler complete a course that has been designed by the rally judge. The judge tells the handler to begin, and the dog and handler proceed at their own pace through a course of designated stations (10 to 20, depending on the level). Each of these stations has a sign providing instructions regarding the next skill that is to be performed. Scoring is not as rigorous as traditional obedience. Rally provides a link from the Canine Good Citizen (CGC) program to obedience or agility competition, both for dogs and handlers. In addition, rally promotes fun and enjoyment for dogs at all levels of competition.

The team of dog and handler moves continuously at a brisk, but normal pace with the dog under control at the handler's left side. There should be a sense of teamwork between the dog and handler both during the numbered exercises and between the exercise signs; however, perfect "heel position" is not required.

Any faults in traditional obedience that would be evaluated and scored as a one-point deduction or more should be scored the same in Rally, unless otherwise mentioned in these rules.

After the judge's Forward command, the team is on its own to complete the entire sequence of numbered signs correctly.

Unlimited communication from the handler to the dog is to be encouraged and not penalized. Unless otherwise specified in these rules, handlers are permitted to talk, praise, encourage, clap their hands, pat their legs or use any verbal means of encouragement. Multiple commands and/or signals using one or both arms and hands are allowed; the handler's arms need not be maintained in any particular position at any time. The handler may not touch the dog or make physical corrections. At any time during the performance, loud or harsh commands or intimidating signals will be penalized.

To the extent applicable and in all things similar, Rally will follow the same General Rules as the South Dakota 4-H Obedience Rules. Exceptions will be those items specifically identified and explained in these Rally Rules.

Females in heat may not be shown in Rally.

Any dog that attempts to bite or attack a human or another dog will immediately be removed from the activity or event. Dogs excused from the show will not receive a ribbon placing. If the incident occurred at the county show, the dog will therefore be ineligible to qualify and compete at the state dog show. Please see page 5-80 for the complete Aggressive Dog Policy.

General Rules

Section 1. Space Requirements

The required minimum area for a rally course is 40 x 50 feet, however 40 x 80 feet is recommended. The floor covering or ground surface must be the same as would be suitable for traditional obedience.

Section 2. Signs and Holders

AKC approved signs will be used in 4-H rally events. The designated wording and symbols must be used. Signs must be a minimum of 8 ½ x 11 inches and a maximum of 11 x 17 inches. Weather conditions should be considered when securing signs and holders. Colors are optional.

Twenty exercise sign holders are required plus one each for the Start and Finish signs. All sign holders or signs (not including those for Start and Finish) will be clearly and sequentially numbered on the course, with numbers approximately 3 inches high. Signs with an asterisk (numbers 5, 6, 7, 8, 9, 10, 17, 18, 19, and 34) may be

used multiple times on a rally course. Two of each of those signs must be available for the judge's use. All other signs may only be used once on any course.

Stationary exercises are any signs indicating a "Halt" or no forward motion.

Section 3. Placement of Signs

Signs will be placed to the right of the handler's path except for those indicating a change of direction, in which case the sign will be directly in front of the handler to aid in that change. Exercises using cones may require entry with the sign on the left. Exact placement of signs is made by the judge while walking the course along the path that will be taken by the handlers. The course for each class will be posted at the ring prior to the familiarization time (see Section 5). The course used for that day's event should accompany the judge's book when turned in to the show committee.

Section 4. Location of Performance in relation to Signs

Except for exercises requiring entry with the sign on the left, exercises are performed near (within 3 feet) the designated signs, either directly in front, or in front and to the left of said signs. When executing signs requiring pace changes, changes must occur at similar intervals. For example, if the handler begins a fast pace 3 feet before the fast sign, s/he must change to a normal pace 3 feet before the normal sign. Likewise, if the handler changes pace as s/he reaches a sign, s/he would change pace again as s/he reaches the next sign.

Section 5. Familiarization Time

Approximately every two hours, the judge will allow a 10-minute walkthrough for handlers without their dogs. The same course should be used at Novice and Advanced levels, so those walk-throughs may be done at the same time. The judge must be available during this period to answer any questions the handlers might have. The judge will also brief the handlers on the course during this period.

Section 6. Judging and Position for Starting

The judge's orders will be, "Are you ready" followed by, "Forward." No other orders are necessary. Timing begins when the judge says "Forward."

Timing ends when the dog and handler cross the finish sign.

The dog can be in a sit, down or stand at the Start sign to begin the Rally course.

Dogs **MUST** enter the ring on leash and exit on leash,

even in Advanced and excellent.

Section 7. Scoring and Ribbon placements

The score sheet and ribbon placing will be recorded and handed out at the completion of each class. Times will be used only to break ties. The following scale will be used:

Score	Ribbon
90-100	Purple
80-89	Blue
70-79	Red
below 69	White

In order to Pass to the next level, the team must earn a minimum of 90 points at County level. Scoring of all levels is based on a maximum score of 100 points. The following deductions shall apply:

1-point deduction for each of the following:

- Tight leash
- Dog interfering with handler
- Poor sits
- Slow, delay or resistance to respond
- Touching or ticking a jump, pylon, post or person
- Out of position

3-point deductions for each of the following:

- Repeat of a station (a maximum of two re-tries allowed)
- Pylon/post knocked over (on Figure Eight, spiral and serpentine)
- Lack of control
- Loud command or intimidating signal
- Excessive barking

10-point deduction for each of the following:

- Incorrectly performed station
- Hitting the jump
- Over the class time limit

1- to 10-point deduction:

- Lack of teamwork
- Lack of briskness
- Handler error

25 -point deduction:

- Eliminating in the ring

Non-Qualifying (NQ) scores shall be given for:

- Minimum requirements not met
- Dog unmanageable, or uncontrolled barking
- Station not attempted
- Consistently tight lead
- Substantially out of position/not completing the honor exercise

- Bar knocked off uprights
- Using a jump as an aid in going over
- Failure of dog to go over the jump in the proper direction
- Handler error (different from the above 10-point deduction. Used when it is evident that the handler does not know how to complete the exercises.)

The table steward is responsible for totaling deductions on the judge's worksheet and transferring them to the judge's book. Final scores may be recorded in the official judge's book by the table steward, however, the judge must verify the scores and sign the book.

Section 8. Timing

All dogs will be timed. Time will begin when the judge says "Forward," and end when the dog and handler cross the Finish. Handlers and dogs are to move briskly. Ideally, courses are designed to be completed within 1 ½ - 2 minutes. A Major fault of 10 points will be deducted for going over the class time limit.

Classes and Advancements

All classes will be divided into the three 4-H age divisions, Beginner, Junior and Senior. Leashes and collars for Rally novice must meet the requirements of basic obedience. Collars in Rally Advanced and Rally excellence must be a properly fitted flat or slip collar. No training collars allowed. **Nothing may be hanging from the collar.**

Section 1. Rally Novice Class – On Leash

All exercises are judged with the dog on leash, and all dogs must enter and leave the ring on leash. Rally Novice must have between 10-15 stations (Start and Finish are not included) with no more than five stationary exercises per class (these may include any of signs 1-42).

Rally Novice is for newer 4-H'ers who have not yet received a minimum passing score of 70 in Rally Novice to proceed to Intermediate. It is also for any experienced 4-H'er that is beginning a new dog. The time limit for this class is 4 minutes.

Section 2. Rally Intermediate and Advanced Classes – On Leash

All dogs will enter and leave the ring on leash. Rally Intermediate and Advanced must have between 12 and 17 stations (Start and Finish not included) with no more than seven stationary exercises per class (these may include any of signs 1-42 and 101-123). The time limit for this class is 3 ½ minutes.

Rally Intermediate is for dogs that have passed 4-H Rally Novice but have not yet received a minimum passing

score of 70 in Intermediate. This class will be judged with the dog ON leash with no jump.

Section 3. Rally Advanced Class – Off Leash

Rally Advanced is for dogs that have passed Rally Intermediate level (or the non 4-H equivalent) but have not yet received a passing score of 70 points in Advanced. This class will be judged with the dog OFF leash and include a jump. A 4-H'er may show in Intermediate and Advanced progressively, or choose to show only in Advanced according to their training level or their show experience outside of 4-H."

Note: The normal 4-H progression is Rally Novice – Intermediate – Advanced – Excellent. Intermediate and Advanced may be skipped at the handler's discretion; it MUST be skipped if s/he has participated in non-4-H Rally competition at the Excellent level.

Section 3a. Jumps

One jump must be used for the Advanced class. It may be any jump used as standard equipment in 4-H obedience classes (broad jump, high jump or bar jump) except that 4-foot wide jumps may be used in place of 5-foot wide jumps. It is the judge's responsibility to see that the jumps are set for each dog in accordance to these Rules.

The broad jump will consist of three telescoping hurdles, each approximately 8 inches wide. The largest hurdle will measure about 4 feet, 10 inches long (if from a 5-foot set) and about 5 inches at the highest point. In the ring, broad jump hurdles will be arranged in order of size from smallest to largest. They will be evenly spaced, covering a distance equal to twice the height of the high jump set for each dog. Three hurdles will be used for a jump of 32 inches, two hurdles for a jump of 16 or 24 inches, or one hurdle for a jump of 4 or 8 inches. When decreasing the number of hurdles in the jump, the highest hurdle will be removed first.

- The high jump consists of two uprights and solid boards of varying widths that combine to make each dog's required jump height.
- The bar jump also has two uprights. These are constructed to support only a striped bar which is set at the dog's required jump height.

Section 3b. Jump Heights

The dog's jump height shall be given on the entry form. Entries may be arranged according to the jump height of the dogs, from either high to low, or low to high.

The dog's height at the withers determines its jump height.

Dog's Height	Height of Jump
under 10 inches	4 inches
10-14 inches	8 inches
14-20 inches	12 inches
over 20 inches	16 inches

New for 2024 – Veteran Jumps For dogs 7 years and older, jumps will be one height lower than their measured jump height.

Section 4. Rally Excellent Class – Off Leash

Rally excellent must have between 15-20 stations (Start and Finish not included) with no more than seven stationary exercises per class (these signs shall include any of all signs numbered 1-42, 101-123, 201-216 and 298-299). All exercises are judged with the dog off leash. Unlike in the Rally Novice and Advanced Classes, in Rally excellent handlers are not allowed to pat their legs or clap their hands to encourage the dog. Verbal encouragement, multiple commands and/or inaudible signals using one or both arms and hands are allowed; the handler's arms need not be maintained in any particular position at any time. Handlers may not touch their dog or make any physical corrections. A dog completing the Rally excellent level may continue to compete at this level indefinitely. Sign 298 and two jumps must be used for this class. Jumps may be any jump or any combination of the jumps that may be used as standard equipment in the obedience classes (broad jump, high jump or bar jump) except that 4-foot jumps may be used in place of 5-foot jumps. Jumps may not be used consecutively in the course. The time limit for this class is 3 minutes.

For more information: Rally-o: The Style of Rally obedience, 3rd edition by Charles 'Bud' Kramer ISBN: B0006ROFZ8

Guidelines for Judges

Classes and Advancements

The 4-H Rally Rules and Guidelines are the basic guide for judging, however, not every possible fault or error is covered, only the more common and serious ones.

Rally Rules (and sign descriptions) clearly define the exercises, their order and the standard by which they are to be judged. The rules set the standard for a perfect score of 100 points by which each dog's performance is judged. The rules give the judge guidelines for how an exercise is to be performed. While rally is not judged with the same precision as formal obedience, rally judges must make decisions based on a mental picture of the perfect performance within the framework of these rules. Studying the 4-H Rally Rules and Guidelines, exhibiting

and attending seminars all increase a judge's knowledge. Putting the acquired knowledge into practice permits a judge to apply the principles of sound judging.

Judges are given full discretionary authority within the framework of the rules, and they must exercise this authority impartially. Judges are required to make their own decisions and accept the responsibility this implies. If a decision depends on the exact wording of a rule, the judge is expected to consult the book before making the decision.

A judge may not discard, modify or require anything not specified in the 4-H Rally Rules and Guidelines. A rally level passed is intended to evoke admiration. Therefore, the accomplishment must be based on performances that fully meet the requirements of the 4-H rules. Scores for each exercise must be amply justified by the performance of the dog and handler. The 4-H handler of any dog receiving a ribbon in rally has every reason to be proud. Earning a qualifying score should indicate a credible performance that fully justifies the achievement level of both the dog AND the youth.

Preparing for Judging

Ring – Upon arrival, the judge should post the course(s) outside the ring. The judge may alter the course because of unforeseen ring conditions and post the change(s). Prior to the scheduled judging time, the judge should inspect the ring, which must meet all the requirements of the 4-H Rally Rules and Guidelines. Size shall be determined by means of the judge pacing the ring. Checking the ring also requires the judge to:

- examine the signs and sign holders to ensure they are secure.
- examine the distractions used in the offset Figure Eight to determine that they can be seen and smelled but not consumed.

Measure the jumps in the Advanced and Excellent classes to ensure they meet the requirements.

Order of exhibitors – The judge should review the entry list and respond to exhibitors requesting a change of order for class conflicts and re-order as they are able. They should review procedures with the Ring Steward to accommodate entrants in other classes, but not to the point of delaying classes. The judge may also arrange entries according to the dog's jump heights, either low to high or high to low. A judge need not mark absentees in the judge's book until the end of the class. Judges are not required to wait beyond the completion of each class for dogs/handler teams.

Judging Schedule – The judging schedule will be based on no more than 15 dogs per hour. Judges may take rest or meal times at their discretion.

Judge's Records

Section 1. Judging the classes

The judge should honor an exhibitor's request to be excused.

Section 2. Judge's Book

When judging is finished, the judge should review and sign the book and mark the time they are finished for the day. The book along with a copy of each course for the classes is then returned to the Rally Chair or Show Chairperson. These books will help the judge to answer questions from exhibitors or parents, provide valuable information into the success and needs of the program for the upcoming year, and help to improve the next year's show by showing numbers of entrants, actual exhibitor numbers, time needed for each class, and where the children and leaders need help in making improvements in their training classes.

Guidelines for Stewards

Introduction

Stewarding functions in the rally ring are broken down into four general categories: gate steward, table steward, ring steward and time steward. In Rally Novice and Rally Advanced, only three stewards are necessary; one person can serve as both the ring steward and the time steward.

The time steward will monitor and report each dog's time to the table steward. Each steward's functions are described below. It is essential that all stewards be at ringside at least 30 minutes prior to the scheduled start of judging to receive any specific instructions from the judge and to assist in setting up the rally ring as directed by the judge.

Job Descriptions

Section 1. Gate Steward

The primary responsibility of the gate steward is to ensure that the next dog to be judged is immediately available when the judge indicates that s/he is ready. As soon as the judge begins judging the dog in the ring, call the next dog and ensure the handler is ringside before the dog in the ring has completed the rally exercises. Dogs may not enter the ring until the judge invites them in. It is the responsibility of the gate steward to ensure that the class judging is not delayed because the judge is waiting for dogs. If the dog listed next on the entry list is not at ringside, do not hesitate to call the next dog in order. Stewards are not required to seek out handlers.

It is the 4-H'er's responsibility to be present and ready when called. Report any absences to the judge at the end of the class. The judge will decide if the 4-H'er is to be marked absent. Follow this procedure, even if the 4-H'er has checked in.

The gate steward also checks in exhibitors. Ask the exhibitor's name and the name of the dog, then check the entry list. For Advanced and Excellent classes, note the jump height of the dog on the entry list. Double-check this with the rules to be sure the dog is jumping the correct height. The gate steward should also take the leash from each handler when the dog is brought into the ring and return it as the dog and handler complete the "Finish" sign but before they leave the ring.

At check in exhibitors may make requests for special consideration, such as asking to be judged out of order or disabled 4-H'ers may have an attendant help them. The gate steward manages these requests, consulting the judge or show chair as necessary.

Section 2. Table Steward

The extent to which a judge uses a table steward varies greatly. Some judges prefer to do their own bookwork and do not feel it is necessary to have the steward perform many of these duties. The steward must receive specific instructions from the judge as to what will be required. Judges must use worksheets to communicate with the table steward. The judge may ask the table steward to prepare and have the worksheet ready for the next dog. Ensure that the class, proper ID Number and breed of dog are entered correctly on the sheet. Double-check to see that the scores on the worksheet have been added correctly. Initial the worksheet and transfer the score and time to the judge's book. If an error is detected, bring it to the attention of the judge, and then enter the corrected score and time in the judge's book.

The table steward ensures that all ribbons are available at the conclusion of judging. The judge may ask the steward to assist in awarding the ribbons and trophies to the exhibitors.

Section 3. Ring Steward

Each judge in Rally will have at least one ring steward. It is particularly important for the ring steward to report to the ring at least 30 minutes prior to judging to assist in setting up the rally course and to receive specific instructions from the judge. During Novice classes, the ring steward should remain outside the ring but stay alert to any possible problems and be ready to follow whatever instructions the judge may give.

For Advanced and Excellent classes, it is essential that the ring steward have a tape measure or steel rule to ensure accuracy in setting the broad jump. The first duty of the judge is to check that the jumps are properly set. Stewards must arrange the jumps quickly and accurately, or much time will be wasted.

- The Jumps – although the gate steward will ask the handler what height the dog jumps, the handler may only know the height of the dog. Therefore, it is essential that the ring stewards be familiar with the Rules in order to set the jumps correctly. See Section 2b for the appropriate chart.

Section 4. Time Steward









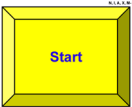

In the Novice and Advanced classes, the ring steward and the time steward may be the same person, however in the Excellent class, two separate stewards are necessary.

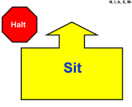
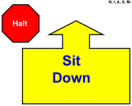









If two or more dogs in a class earn the same score, the tie is broken by time. The timer is positioned outside the ring in a place specified by the judge. The timer should be lined up with the Start sign. When the judge gives the order "Forward," the timer starts the stopwatch and stops it when the dog and handler cross the Finish station. Times are reported immediately to the table steward after each dog completes the course.







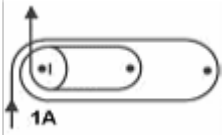
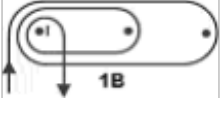

Rally Signs and Descriptions

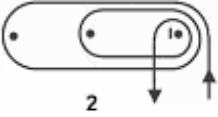

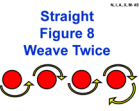
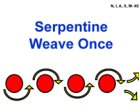
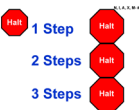



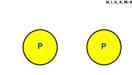
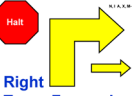
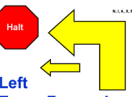

Judges may use duplicates of stations marked with an asterisk in designing their courses.

The Principal Parts are **boldface and underlined**.







Description	Sign
1. START – Indicates the beginning of the course. The dog does not have to be sitting at the start.	
2. FINISH – Indicates the end of the course - timing stops.	
3. HALT – Sit – While heeling, <u>the handler halts and the dog sits</u> in heel position. (Stationary)	
4. HALT – Sit – Down – While heeling, <u>the handler halts and the dog sits</u> in heel position. <u>The dog must then down</u> in heel position. (Stationary)	
5. * Right Turn – 90° turn to the right.	
6. * Left Turn – 90° turn to the left.	
7. * About Turn – Right – 180° turn to the right.	
8. * About “U” Turn – 180° turn to the left.	
9. * 270° Right Turn – While heeling, <u>the dog and handler make a tight 270° turn to the right.</u>	
10. * 270° Left Turn – While heeling, <u>the dog and handler make a tight 270° turn to the left.</u>	
11. 360° Right Turn – While heeling, <u>the dog and handler make a tight 360° turn to the right.</u>	







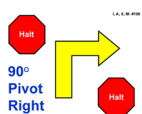
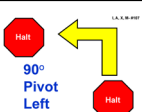
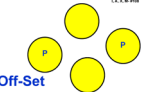
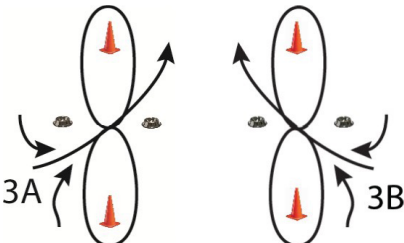



Description	Sign
12. 360° Left Turn – While heeling, the dog and handler make a tight 360° turn to the left.	
13. Call Front – Finish Right – Forward – While heeling, the handler stops forward motion and calls the dog to front. The handler may take several steps backward. The dog must come and sit in front. Without the handler moving their feet, the dog must finish to the right. As the dog clears the handler's path, the handler will heel forward before the dog returns to heel position. (Stationary)	
14. Call Front – Finish Left – Forward – While heeling, the handler stops forward motion and calls the dog to front. The handler may take several steps backward. The dog must come and sit in front. Without the handler moving their feet, the dog must finish to the left. As the dog clears the handler's path, the handler will heel forward before the dog returns to heel position. (Stationary)	
15. Call Front – Finish Right – Sit – While heeling, the handler stops forward motion and calls the dog to front. The handler may take several steps backward. The dog must come and sit in front. Without the handler moving their feet, the dog must finish to the right and sit in heel position. (Stationary)	
16. Call Front – Finish Left – Sit – While heeling, the handler stops forward motion and calls the dog to front. The handler may take several steps backward. The dog must come and sit in front. Without the handler moving their feet, the dog must finish to the left and sit in heel position. (Stationary)	
17. Slow Pace – The dog and handler must slow down noticeably. This must be followed by a normal pace sign unless it is the last station on the course.	
18. Fast Pace – The dog and handler must speed up noticeably. This must be followed by a normal pace sign.	
19. *Normal Pace – The dog and handler walk briskly. This sign is only used after a slow or fast pace sign.	
20. Moving Side Step Right – While heeling, the handler takes one step to the right, leading with the right foot , and continues heeling along the newly established line. The dog must move with the handler. This sign will be placed directly in line of the team's path requiring the handler and dog to sidestep to the right to pass the sign.	
21. Spiral Right – Dog Outside – This sign requires three pylons placed in a straight line with spaces between them of approximately 6-8 feet. The dog and handler must turn to the right to move around each of the pylons.	  

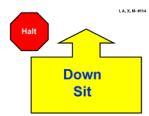
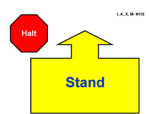
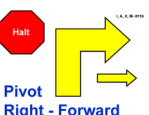

Description	Sign
<p>22. Spiral Left – Dog Inside – This sign requires three pylons placed in a straight line with spaces between them of approximately 6-8 feet. <u>The dog and handler must turn to the left to move around each of the pylons.</u></p> 	
<p>23. Straight Figure 8 Weave Twice – This sign requires four pylons placed in a straight line with spaces between them of approximately 6-8 feet. <u>The dog and handler will enter into the weave with the first pylon on their left side. They must complete the entire weave twice.</u></p>	
<p>24. Serpentine Weave Once – This sign requires four pylons placed in a straight line with spaces between them of approximately 6-8 feet. <u>The dog and handler will enter into the weave with the first pylon on their left side. They must complete the entire weave once.</u></p>	
<p>25. HALT – 1, 2 and 3 Steps – While heeling, <u>the handler halts and the dog sits</u> in heel position. <u>The handler takes one step forward, halts and the dog sits</u> in heel position. <u>The handler takes two steps forward, halts and the dog sits</u> in heel position and then <u>three steps forward, halts and the dog sits</u> in heel position. The dog moves with the handler each time. (Stationary)</p>	
<p>26. Call Front – 1, 2 and 3 Steps Backward – Forward – While heeling, <u>the handler stops forward motion</u> and calls the dog to front. The handler may take several steps backward. <u>The dog must come and sit</u> in front. <u>The handler takes one step backward and halts. The dog must move with the handler and sit</u> in front as the handler halts. <u>The handler takes two steps backward and halts. The dog must move with the handler and sit</u> in front as the handler halts. <u>The handler takes three steps backward and halts. The dog must move with the handler and sit</u> in front as the handler halts. The handler may command/signal the dog to finish. As the dog clears the handler's path, the handler will heel forward before the dog returns to heel position. (Stationary)</p>	
<p>27. Stop and Down – While heeling, <u>the handler stops forward motion and the dog downs</u> in heel position. <u>The dog must stay down until the handler moves forward.</u> (Stationary)</p>	
<p>28. HALT – Fast Forward from Sit – While heeling, <u>the handler halts and the dog sits</u> in heel position. <u>The dog and handler</u> then heel forward <u>at a fast pace</u>. This must be followed by a normal pace sign. (Stationary)</p>	
<p>29. Left About Turn – While heeling, <u>the handler will make an about turn to the left</u>, while at the same time <u>the dog must move around the handler to the right</u> and into heel position.</p>	
<p>30. HALT – Walk Around – While heeling, <u>the handler halts and the dog sits</u> in heel position. <u>The dog must stay while the handler walks around behind the dog, returns and pauses.</u> The handler must pause before heeling forward. (Stationary)</p>	
<p>31. HALT – Down – Walk Around – While heeling, <u>the handler halts and the dog sits</u> in heel position. <u>The dog must then down and stay while the handler walks around behind the dog, returns</u> to heel position <u>and pauses.</u> The dog and handler then heel forward. (Stationary)</p>	

Description	Sign
32. Figure 8 – No Distractions – This sign requires two pylons spaced approximately 6-8 feet apart. The Figure 8 may be entered with the pylons on either the left or right side. <u>The dog and handler will perform a complete figure 8 around the pylons, crossing the center line three times.</u>	 <p>Figure 8 No Distractions</p>
33. HALT – Right Turn – Forward – While heeling, <u>the handler halts and the dog sits</u> in heel position. <u>The handler and dog turn right</u> together and heel forward. (Stationary)	 <p>Right Turn - Forward</p>
34. HALT – Left Turn – Forward – While heeling, <u>the handler halts and the dog sits</u> in heel position. <u>The handler and dog turn left</u> together and heel forward. (Stationary)	 <p>Left Turn - Forward</p>
35. Call Front – Return to Heel – While heeling, <u>the handler stops forward motion</u> and may command/signal the dog to front. The handler may take several steps backward. <u>The dog must come and sit</u> in front. <u>The dog must stay while the handler walks around behind the dog to return</u> to heel position. <u>The handler must pause before heeling forward.</u> (Stationary)	 <p>Call Front Return to Heel</p>
36. HALT – Slow Forward From Sit – While heeling, <u>the handler halts and the dog sits</u> in heel position. <u>The dog and handler</u> then heel forward <u>at a slow pace.</u> This must be followed by a normal pace sign unless it is the last sign on the course. (Stationary)	 <p>Slow Forward From Sit</p>
37. Loop Right – While heeling, <u>the dog and handler loop right crossing over the original path.</u>	 <p>Loop Right</p>
38. Loop Left – While heeling, <u>the dog and handler loop left crossing over the original path.</u>	 <p>Loop Left</p>
39. Diagonal Right – While heeling, <u>the dog and handler make an open angle turn to the right.</u> <u>The dog must move with the handler.</u> This sign will be placed directly in line of the team's path.	 <p>Diagonal Right</p>
40. Diagonal Left – While heeling, <u>the dog and handler make an open angle turn to the left.</u> <u>The dog must move with the handler.</u> This sign will be placed directly in line of the team's path.	 <p>Diagonal Left</p>
41. Offset Serpentine Right – This sign requires three pylons. The center pylon will be offset to the right by 3-4 feet with the other two spaced approximately 6-8 feet apart. <u>The dog and handler will enter into the weave with the first pylon on their right side. They must complete the entire serpentine together.</u>	 <p>Off Set Serpentine Right</p>
42. Offset Serpentine Left – This sign requires three pylons. The center pylon will be offset to the left by 3-4 feet with the other two spaced approximately 6-8 feet apart. <u>The dog and handler will enter into the weave with the first pylon on their left side. They must complete the entire serpentine together.</u>	 <p>Off Set Serpentine Left</p>









The following signs may be used in the intermediate, advanced, excellent and master classes
 Except sign 103 may not be used in the intermediate or master classes

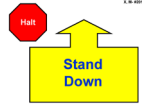





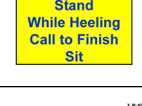

Description	Sign
101. HALT – About Turn Right – Forward – While heeling, <u>the handler halts and the dog sits.</u> <u>The dog and handler turn 180° to the right</u> and heel forward. (Stationary)	
102. HALT – About “U” Turn – Forward – While heeling, <u>the handler halts and the dog sits.</u> <u>The dog and handler turn 180° to the left</u> and heel forward. (Stationary)	
103. *Send over Jump – Handler Passes By – <u>The dog must clear the jump on the first attempt, in the proper direction</u> without stopping, while <u>the handler passes by without stopping.</u>	
104. HALT – Turn Right One Step – Call to Heel – HALT – While heeling, <u>the handler halts and the dog sits.</u> <u>The dog must stay sitting while the handler turns, takes one step to the right, halts and calls the dog to heel.</u> <u>The dog must then return to the handler</u> to heel position <u>and sit.</u> (Stationary)	
105. HALT – Stand – Walk Around – While heeling, <u>the handler halts and the dog sits.</u> <u>The dog must then stand and stay while the handler walks around behind the dog, returns</u> to heel position <u>and pauses.</u> The dog and handler then heel forward. The handler may move forward with the dog to stand it. In the Intermediate and Advanced classes the handler may touch the dog to stand it. <u>In the Excellent and Master classes the handler may not touch the dog to stand it.</u> (Stationary)	
106. HALT – 90° Pivot Right – HALT – While heeling, <u>the handler halts and the dog sits.</u> <u>The dog and handler pivot 90° to the right together and the dog sits</u> in heel position. (Stationary)	
107. HALT – 90° Pivot Left – HALT – While heeling, <u>the handler halts and the dog sits.</u> <u>The dog and handler pivot 90° to the left together and the dog sits</u> in heel position. (Stationary)	
108. Offset Figure 8 – This sign requires two pylons spaced about 6-8 feet apart. The two distractions will be placed to the sides about 5-6 feet apart. The Figure 8 may be entered with the pylons on either the left or right side. <u>The dog and handler and will perform a complete figure 8 together around the pylons, crossing the center line three times without disturbing the distractions.</u> The distractions will be securely covered containers with tempting dog treats or dog safe toys may be used in place of dog treats.	 
109. HALT – Side Step Right – HALT – While heeling, <u>the handler halts in front of the sign and the dog sits.</u> <u>The dog and handler move one step directly to the right together.</u> <u>The handler halts and the dog sits</u> in heel position. This sign will be placed directly in line of the team's path requiring the dog and handler to sidestep to the right to pass the sign. (Stationary)	

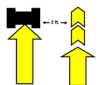
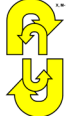
Description	Sign
110. HALT – Call Front – Finish Right – While heeling, <u>the handler halts and the dog sits.</u> <u>Without the handler moving their feet, the dog must then come and sit</u> in front. <u>Without the handler moving their feet, the dog must finish to the right and sit</u> in heel position. (Stationary)	
111. HALT – Call Front – Finish Left – While heeling, <u>the handler halts and the dog sits.</u> <u>Without the handler moving their feet, the dog must then come and sit</u> in front. <u>Without the handler moving their feet, the dog must finish to the left and sit</u> in heel position. (Stationary)	
112. HALT – 180° Pivot Right – HALT – While heeling, <u>the handler halts and the dog sits.</u> <u>The dog and handler pivot 180° to the right together and the dog sits</u> in heel position. (Stationary)	
113. HALT – 180° Pivot left – HALT – While heeling, <u>the handler halts and the dog sits.</u> <u>The dog and handler pivot 180° to the left together and the dog sits</u> in heel position. (Stationary)	
114. HALT – Down – Sit – While heeling, <u>the handler halts and the dog sits.</u> <u>The dog must then down and sit.</u> (Stationary)	
115. HALT – Stand – While heeling, <u>the handler halts and the dog sits.</u> <u>The dog must then stand</u> in heel position. The handler may move forward with the dog to stand it. In the Intermediate and Advanced classes the handler may touch the dog to stand it. <u>In the Excellent and Master classes the handler may not touch the dog to stand it.</u> (Stationary)	
116. HALT – Pivot Right – Forward – While heeling, <u>the handler halts and the dog sits.</u> <u>The dog and handler pivot 90° to the right together</u> and heel forward. (Stationary)	
117. HALT – Pivot Left – Forward – While heeling, <u>the handler halts and the dog sits.</u> <u>The dog and handler pivot 90° to the left together</u> and heel forward. (Stationary)	
118. HALT – Leave 2 Steps – Call to Heel – Forward – While heeling, <u>the handler halts and the dog sits.</u> <u>The dog must stay while the handler takes two steps forward and pauses.</u> The handler begins to heel forward and commands the dog to heel. <u>The dog must speed up noticeably</u> to return to heel position. (Stationary)	
119. Right Turn – Dog Circles Right – Forward – While heeling, <u>the handler turns right and the dog circles around the handler to the right</u> returning to heel position and heeling forward. The handler may pause as needed.	
120. Left Turn – Dog Circles Right – Forward – While heeling, <u>the handler turns left and the dog circles around the handler to the right</u> returning to heel position and heeling forward. The handler may pause as needed.	
121. HALT – Step in Front – Finish Right – Forward – While heeling, <u>the handler halts and the dog sits.</u> <u>The handler steps in front to face the dog.</u> <u>Without the handler moving their feet, the dog must finish right.</u> As the dog clears the handler's path, the handler will heel forward before the dog returns to heel position. (Stationary)	

Description	Sign
122. HALT – Step in Front – Finish Left – Forward – While heeling, <u>the handler halts and the dog sits. The handler steps in front to face the dog. Without the handler moving their feet, the dog must finish left.</u> As the dog clears the handler's path, the handler will heel forward before the dog returns to heel position. (Stationary)	
123. 2 Side Steps Right – Forward – While heeling, <u>the handler will take two side steps to the right, leading with the right foot,</u> and continue heeling along the newly established line. <u>The dog must move with the handler.</u> This sign will be placed directly in line of the team's path requiring the dog and handler to side step to the right to pass the sign.	

The following signs may be used in the excellent and master classes.
Except sign 210 may not be used in the master class.

Description	Sign
201. HALT – Stand – Down - While heeling, <u>the handler halts and the dog sits. The dog must stand and then down without the handler moving their feet or touching the dog. The dog must remain down until the handler moves forward.</u> (Stationary)	
202. HALT – Stand – Sit – While heeling, <u>the handler halts and the dog sits. The dog must stand and then sit without the handler moving their feet or touching the dog. The dog must remain sitting until the handler moves forward.</u> (Stationary)	
203. Moving Stand – Walk Around – While heeling, <u>the dog must stand and stay as the handler, without pausing, walks around behind the dog, returns</u> to heel position <u>and pauses.</u> The dog and handler then heel forward. (Stationary)	
204. Moving Down – Walk Around – While heeling, <u>the dog must down and stay as the handler, without pausing, walks around behind the dog, returns</u> to heel position <u>and pauses.</u> The dog and handler then heel forward. (Stationary)	
205. Back Up 3 Steps – While heeling, <u>the dog and handler reverse direction walking backward at least 3 steps together</u> and then continue heeling forward. <u>The dog must remain standing throughout.</u>	
206. Down While Heeling – Call to Finish – Sit – While heeling, <u>the dog must down and stay as the handler, without pausing, continues about 6 feet to the Call sign and turns to face the dog. Without moving their feet,</u> the handler may command/signal the dog to finish. <u>The dog must finish</u> to the right or left <u>and sit</u> in heel position.(Stationary)	
207. Stand While Heeling – Call to Finish – Sit – While heeling, <u>the dog must stand and stay as the handler, without pausing, continues about 6 feet to the Call sign and turns to face the dog. Without moving their feet,</u> the handler may command/signal the dog to finish. <u>The dog must finish</u> to the right or left <u>and sit</u> in heel position. (Stationary)	
208. Stand – Leave – Sit – Call Front – Finish – Sit – While heeling, <u>the handler will stop forward motion; the dog must stand and stay. The handler will walk about 6 feet to the Call sign and turn to face the dog. The dog must then sit, come and sit</u> in front. <u>Without moving their feet,</u> the handler may command/signal the dog to finish. <u>The dog must finish</u> to the right or left <u>and sit</u> in heel position. (Stationary)	
209. Stand – Leave – Down – Call Front – Finish – Sit – While heeling, <u>the handler will stop forward motion; the dog must stand and stay. The handler will walk about 6 feet to the Call sign and turn to face the dog. The dog must then down, come and sit</u> in front. <u>Without moving their feet,</u> the handler may command/signal the dog to finish. <u>The dog must finish</u> to the right or left <u>and sit</u> in heel position. (Stationary)	

Description	Sign
210. Send to Jump – At the sign the dog must leave the handler to jump. The dog must clear the jump on the first attempt, in the proper direction without stopping. The handler must remain at least 3 feet away from the jump and may not pass the jump until the dog has returned to heel position. (See Chapter 2, Section 23)	 Send To Jump
211. Double Left About Turn – While heeling, the handler will make an about turn to the left , while at the same time the dog must move around the handler to the right and into heel position. The handler will take two or three steps before the dog and handler complete the left about turn a second time.	 Double Left About Turn
212. About Turn Right – About U Turn – While heeling, the dog and handler turn 180° to the right , take two or three steps forward and then turn 180° to the left.	 About Turn Right About U Turn
213. About U Turn – About Turn Right – While heeling, the dog and handler turn 180° to the left , take two or three steps forward and then turn 180° to the right.	 About U Turn About Turn Right
214. Stand – Right Turn – Forward – While heeling, the handler stops and without touching the dog, the dog stands in heel position. The dog and handler turn right and then heel forward. (Stationary)	 Stand Right Turn Forward
215. Stand – Left Turn – Forward – While heeling, the handler stops and without touching the dog, the dog stands in heel position. The dog and handler turn left and then heel forward. (Stationary)	 Stand Left Turn Forward
216. HALT – Dog Circles Right – SIT – While heeling, the handler halts and the dog sits. The dog circles around the handler to the right , returns to heel position and sits. (Stationary)	 Dog Circles Right Sit
298. Sit Stay – The dog must remain in the sit position while the handler gets the leash, walks around behind the dog to return to heel position and until the judge says “Exercise Finished.” (See Chapter 2, Section 23)	 Sit Stay
299. *Call – This sign will be used as a marker for associated signs. (See Chapter 2, Section 23)	 Call

Section 4

Dog Showmanship

Dog Showmanship

Purpose of showmanship

Showmanship helps 4-H members develop skills and knowledge in dog show handling. It allows 4-H members to learn about breeds of dogs and general grooming responsibilities. In showmanship; versus obedience, rally obedience and agility, the judge evaluates the handler's knowledge and experience. The guidelines and score sheets outline the minimum expectations for performance; however, this may vary somewhat with each judge. In contrast, in agility the handler guides the dog through the course and the dog either can do the obstacle or not, a very clear result. This difference in evaluation takes into account the team's readiness to move up to the next level of showmanship; for example, confidence, poise, knowledge and lead handling.

Showmanship competition

Showmanship competition provides 4-H members with a meaningful experience where they can practice and improve their handling and sportsmanship skills. Showmanship gives each 4-H member the opportunity to present themselves and their dog to the best of their ability. This is exemplified by a handler working as a team with his or her dog, so the dog is stacked, alert and under control, while at the same time the 4-H'er appears confident and in control. It is important to remember at all times that the 4-H showmanship ring is not the AKC showmanship ring. (In the AKC showmanship ring the dog is being judged, while in 4-H the handler is being judged.)

Showmanship will be evaluated on the following five basic areas:

1. Proper breed presentation
2. Ring procedure
3. Knowledge
4. Grooming of dog
5. 4-H'ers appearance and conduct

Competition Rules

Eligibility for Participation

Any dog may be shown in 4-H showmanship, regardless of breed or cross. Conformation of the dog is not evaluated in 4-H showmanship. A mixed breed dog should be shown by the breed standard it most closely resembles, even if it is not a cross of that breed.

No dog in season may be shown.

Any dog that attempts to bite or attack a human or another dog will immediately be removed from the activity or event. Dogs excused from the show will not receive a ribbon placing. If the incident occurred at the county show, the dog will therefore be ineligible to qualify and compete at the state dog show. Please see page 5-80 for the complete Aggressive Dog Policy.

Classes

There are two showmanship classes:

- Novice: For 4-H members who have never earned a purple ribbon at the state show level.
- Open: For 4-H members who have earned purple ribbon at the state show level in Novice. Because showmanship is based on the 4-H'ers ability, they may not drop back to novice if they use a new dog for showmanship. If a member chooses not to go on to the State Dog Show the County Project Leader and Member may use their own discretion and advance to the next level.

In 4-H showmanship, members advance from novice to open through each age level.

- Beginner Class will be for ages 8-10
- Junior Class will be for ages 11-13
- Senior Class will be for ages 14-18

Hardship Clause

If a 4-H'er's dog should get injured, killed or an intact female come in season after the county Achievement Days, he/she is allowed to substitute another dog for the South Dakota State 4-H Dog Show. This is only allowed in the Showmanship area of the dog project.

Eliminating in the Ring

The 4-H'er will be docked one ribbon placing for any dog that eliminates in the ring.

Leads

There are several types of showmanship leads. They come in many styles, sizes, weights and colors. Some include:

- Loop lead – this type has a loop at the end that slips over the dog's head. Caution should be used when showing with this lead, so that it does not slip off the dog's head.
- Martingale – this type has an additional loop at the end of the first loop and the dog's head is placed

between the two loops. This allows the handler to have more control with the dog.

- Slip collar with a short leash/lead – this type is like those sometimes used in obedience but with a lead of 4 feet or less. The size of links should be appropriately matched to the size of the dog. It is appropriate for beginning and/or large and/or strong dogs to be shown with a slip collar.

A showmanship lead is preferred, but no deduction shall be made for obedience leashes AT THE BEGINNER LEVEL ONLY. The size/weight of the lead should be appropriate for the size and/or breed of the dog. Most large dogs should not be shown on lightweight leads.

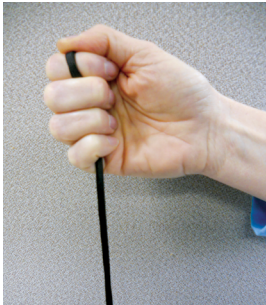

Lead held correctly.



Lead held incorrectly.



Lead placed correctly on dog.



Lead placed incorrectly on dog.

Regardless of which lead is used, the handler must be in control of the dog and the lead shall be held and used neatly. Deductions shall be made for leads hanging down or flapping about the dog. The handler's lead should be ready at all times and deductions shall be made for time spent wrapping leads and getting ready to move out.

In the 4-H showmanship ring, the lead should never be removed when presenting the dog to the judge.

Use of Bait

New for 2024 Baiting is allowed at both Novice and Open showmanship classes. If a 4-H'er uses bait, it must be used discreetly, with no deliberate baiting near other dogs. If the bait is dropped in the ring and not immediately picked up OR is used to deliberately distract other dogs, the 4-H'er will automatically receive a white

ribbon. Small toys are allowed in the 4-H showmanship ring, and a squeaker may be used only during individual examination.

The purpose of baiting is to animate the dog when stacking it in the lineup or during individual presentation to the judge. Dogs show animation and/or expression by either wagging their tail or perking up their ears. Bait is also used to free stack the dog and keep his/her attention. (For a description of "free stack" look under the heading titled "stacking.")

- Baiting is to be done discreetly, without a lot of fanfare and flare. Never stretch an arm out when holding the bait so that it catches any other dog's attention. Be respectful of the others in the ring.
- The size of the food bait pieces should be appropriate for the size of the dog. Semi-moist food chunks work best because they can be easily handled and quickly broken off without too much mess. Dry/hard bones or food cannot quickly be broken into smaller pieces. Bait should not be messy or goeey.
- "Mouth bait" (like hot dogs) that is actually kept in your mouth is not permitted in the 4-H ring. This is to prevent any accidental choking. While this type of bait certainly has its merits, it is not appropriate in 4-H for safety reasons.
- Keep bait in a bait bag or in a skirt, pants or jacket pocket until ready to use it.
- Do not take the bait out of the pocket or bait bag until in the ring and the judge has placed the group in the order, he/she wants it to be in. If free stacking the dog, use the bait as needed to stack. If hand stacking the dog, bait is not needed until after the dog has been stacked, for animation, as the judge is looking the group over.
- Be sure to put the bait back in a bait bag or pocket before gaiting around the ring in a group. Never, ever leave the bait in the hand when not using it.
- Put any bait away right before the judge approaches for the individual examination of the dog.
- When doing an individual gaiting pattern, keep the bait in a pocket or bait bag. While completing the pattern and returning to the judge, take the bait out to present the dog to the judge.
 - Bait should be held directly in front of the dog. At what height/level to hold the bait depends on the size of the dog and experience of the handler. Again, think of the overall picture being created for the judge.
If bait is held too high for a big dog, it will throw the balance of the dog totally off – big dogs have a habit of reaching for something high.

- If small dogs are baited too low, they do not respond.
- Never, ever throw the bait while in the 4-H showmanship ring. Never toss the bait in the air, expecting to catch it while trying to get the dog's attention. (You may not catch the bait.) This is just common courtesy and respect to other dogs and 4-H'ers in the ring.

Clothing: Animal Exhibitor Dress Code

All state fair-related animal exhibitors will receive and are to wear a t-shirt donated by Farm Credit Services (FCS) of America while in the show ring. Youth may pick up t-shirts when they arrive at the show or wear an FCS shirt from a previous year. The t-shirts are intended to recognize the presence and importance of 4-H at the South Dakota State Fair's 4-H division and related events, and emphasize the importance of proper dress, uniformity, and equal representation for all participating youth.

Animal Exhibitors are required to wear suitable clothing that is neat, clean and upholds the image of 4-H when in the show ring. Shirts must have sleeves with shirttails tucked into long, dark colored jeans or pants. No clothing or equipment with commercial advertising is allowed, except in cases where shirts are sponsored and/or provided to the exhibitor for dress code purposes. For safety purposes, wear closed-toe shoes that encase the entire foot up to or beyond the ankle when exhibiting livestock.

An arm band issued during on-site check-in must be worn each time the youth enters the show ring. Youth not adhering to this dress code will be excused from the show ring.

Ring Procedure

Individual judges vary their judging routine and the following components may be mixed in any order. Basic procedure includes:

1. Gaiting by group and individual
2. Stacking (posing) the dog
3. Individual examination of dog

Gaiting

Make gaiting smooth, straight and the correct speed. When in motion, the dog should move naturally and freely. Avoid traveling ahead of or behind the dog.

Always keep the show lead in the hand that is beside the dog. Unlike in Obedience, the arm should be extended out from the side, held above the dog's head. Do not keep the lead too tight or too loose for the breed or

individual dog. The lead should never be so tight as to pull the dog's feet off the ground.

Avoid unnecessary motions or noises that detract from the gaiting procedure. Use the entire ring unless the judge instructs otherwise. If a mat is used, it is for the dog to gait on without slipping. The dog should be centered on the mat while gaiting with the 4-H'er off to the side. If the mat is wide enough, the handler should gait on the mat, too.)

The dog is to be kept between the judge and handler at all times. It is a major fault if the 4-H'er is between the judge and the dog for a significant amount of time (examples: an entire side of the ring, entire pattern, all the way around the ring). It is a minor fault if the handler is between the judge and the dog for a minimal amount of time and he/she corrects the mistake.

It is very important for the handler to have economy of motion and minimize hand switching as much as possible.

A courtesy turn is optional in 4-H but is recommended to get the dog moving or to reposition the dog during a pattern. As the courtesy turn is completed the handler continues directly into the designated pattern with no stop in between. At this point it is acceptable for the 4-H'er to briefly pass between his/her dog and the judge. To execute the courtesy turn, it is done at the beginning of the individual pattern, by stepping away from the judge either beside or in front of the judge; turning to the right, doing a 270 degree turn, (refer to Rally guidelines), then step away to the pattern assigned. If the courtesy turn cannot be executed smoothly, it should not be done because it then detracts from the overall teamwork.

Group Gaiting

Enter the ring in the order assigned by the steward. The judge may choose to rearrange the dogs according to size and/or speed.

During group gaiting, the 4-H'er and dog will always move counter-clockwise around the ring. Under no circumstances will a judge direct the group to move clockwise around the ring. Gaiting is usually done around the perimeter of the ring with dogs on the left side of the handler. Passing should never be done except at the judge's request.

Showing 4-H Dogs on the Table

- The use of the table is optional at the county level but will be used at the state level. See the list of dogs that are usually tabled at the end of this section. The judge will forego the table if a handler's size is too small to lift their dog safely.
- The showmanship table is a regular grooming table, without the grooming arm. The suggested size is 18 inches wide and 30 inches long.
- There is no hard and fast rule for the placement of the table in the show ring. It should be placed sensibly, to prevent a lot of wasted time and wasted steps for the judge. It should not be placed in a spot that would be in the way of the gaiting dog and handler.
- After the handler places his/her dog on the table s/he will stand on the far side of the table facing the showmanship class, the judge will stand with his/her back to the class. The judge may move from his/her side to the front or back of the table but never on to the same side of the table as the handler.
- The dog is stacked according to the breed (See: AKA Breeds by Group at www.akc.org). The Judge will usually observe the side of the dog from the middle of the ring, then move to the front of the table. At this

point the judge may ask the 4-H'er to show the bite and will then check the grooming.

- The dog should be carefully lifted onto the table and then stacked. Don't expect perfection right away, when working with dogs that are not used to being on the table, be patient. This takes some training for the dog to get used to it. Use praise, and occasional treats, to help the dog feel comfortable.

The front feet should be placed near center front edge of the table; they should be close to the edge but not touching the metal edging. It is permissible to carefully lift a small breed by its chest and gently set it into position. Never use the dog's tail to lift him up or to put him in position. Great care when lifting the dog down from the table as some dogs may get excited and try to jump. **NOTE:** If a Whippet is shown on the table, they jump on and off on their own – do not lift them.

The end of the lead should be placed over the handler's shoulder – it is also acceptable to hold the lead in the hand.

The dog's head should be up, and the dog should remain quiet and still in order for the judge to go over it for grooming.

Breeds Usually Shown on the Table

Non-Sporting Group:

- American Eskimo
- Bichon Frise
- Boston Terrier
- French Bulldog
- Lhasa Apso
- Lowchin
- Poodle (miniature)
- Schipperke
- Tibetan Spaniel
- Shiba Inu
- Tibetan Terrier

Hound Group:

- Basenji
- Beagles
- Dachsund
- Petit Basset Griffon Vendeen
- Whippet

Sporting Group:

- Cocker Spaniels
- English Cocker Spaniels

Herding Group:

- Cardigan Welsh Corgi
- Pembroke Welsh Corgi
- Puli
- Shetland Sheepdog
- Swedish Vallhund

Working Group:

- No dogs

Toy Group:

- All dogs are usually tabled.

Gaiting Patterns

Pattern Key:

Solid line with arrows = Handler

Broken Arrows = Dog

J = Judge

It is important that handlers leave space between themselves and the dogs in front of them for safety reasons and to give the judge the best view of their dog. Crowding other dogs is a major fault.

During group gaiting, when the faster dogs are at the front of the line and “catch up” to the smaller dogs at the end of the line, it is appropriate for the 4-H'er to slow down the gait of his/ her dog. Those with a faster/larger dog should continue gaiting at a slower speed, even if it is not the proper speed for his/her breed.

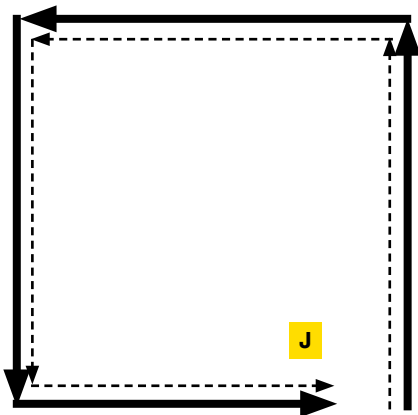

Individual Gaiting

During individual gaiting, the 4-H'er should move the dog at the correct speed for its breed. He/she needs to move at a speed that will match the dog's appropriate gait. Trotting is when one front leg and the opposite rear leg move forward at the same time.

Pacing is when the legs on the same side of the dog move forward at the same time. Gaiting will allow the judge to evaluate the dog's side, front or rear movement. The judge needs to be able to see how the dog's legs move along a straight line. The 4-H'er will be asked to perform one or more of the following patterns:

1. Down and back all levels
2. Triangle pattern all levels except Cloverbuds
3. “L” and “T” for Open Juniors and Open Seniors

“Triangle” Pattern

This pattern is performed in the shape of a right triangle. The handler and dog will proceed in a straight line away from the judge to the opposite end of the ring. At the corner make a left turn and proceed all the way to the next corner. Then one of three turns may be made before proceeding up the diagonal and back to the judge. Under no circumstances may a judge direct a handler to do a reverse triangle where the s/he would go down the diagonal first.

Here are the three variations to the triangle pattern turn:

1. The easiest option is to simply make a left turn onto the diagonal. The handler does not switch hands with the lead and the dog stays on the handler's left side.

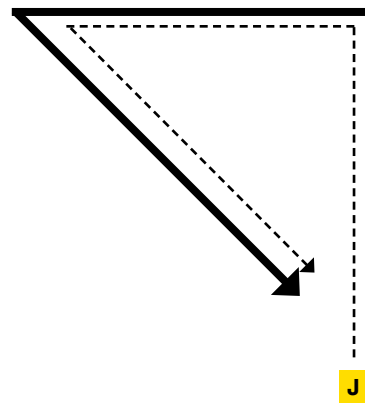

2. The second option is to make a circle in the corner (called a courtesy turn) with the dog always remaining on the handler's left side. The 4-H'er does not switch hands with the lead. At this point it is acceptable to briefly pass between the dog and the judge.

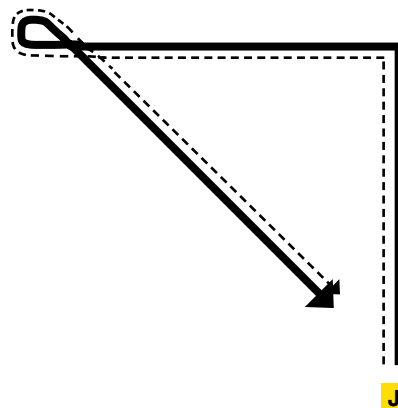

- The third option is for the handler to switch hands with the lead and cross the dog over in front of him/her. The dog completes a circle as the 4-H'er and dog turn into/toward each other and proceed up the diagonal with the dog on his/her right side.

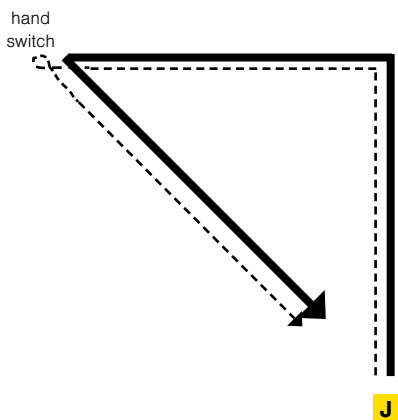

“L” Pattern

This pattern is performed in the shape of an uppercase letter “L.” The handler and dog will proceed in a straight line away from the judge to the opposite end of the ring. At the corner make a left turn and proceed all the way to the next corner, switching hands with the lead. The handler and dog turn into/toward each other and proceed back to the other end of the ring. At the final corner, the handler again has three options for executing the final turn.

- The easiest option is to simply make a right turn and proceed back to the judge. The 4-H'er does not switch hands with the lead and the dog stays on the 4-H'er's right side.

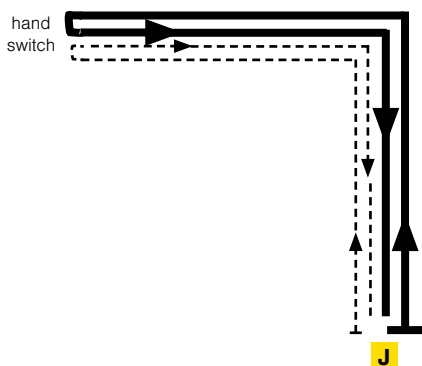

- The second option is to make a circle in the corner (courtesy turn) with the dog always remaining on the 4-H'er's right side. Do not switch hands with the lead.
- The third option is for the 4-H'er to switch hands with the lead and cross the dog over in front of him/her. The dog completes a circle as the handler and dog

turn into/toward each other and proceed back to the judge with the dog on the his/her left side.

“T” Pattern

This pattern is performed in the shape of an uppercase letter “T.” The judge will indicate where to start the “T” pattern. The 4-H'er and dog will proceed in a straight line away from the judge to the opposite end of the ring. The 4-H'er should turn to the left and proceed to the corner of the ring. He/she then switches hands with the lead. The 4-H'er and dog turn into/toward each other and proceed to the other end of the ring. At the other end, he/she again switches hands with the lead. The handler and dog again turn into/toward each other and proceed back to the center of the ring.

The 4-H'er then turns back toward the judge and proceeds in a straight line back to the judge.

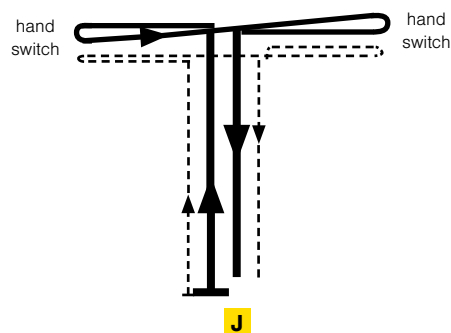

Down and Back

The 4-H'er and dog will be asked to gait across the ring either on the diagonal or from end to end. At the opposite end of the ring, the 4-H'er has the option to do (1) an about turn or (2) to switch hands with the lead.

- If an about turn is executed, the dog stays on the same side (left or right) and goes around the outside of the handler.
- If the handler switches hands with the lead, he/she and dog turn into/ toward each other and proceed to the other end of the ring. The dog ends up on the opposite side of the handler from where it originally started (left to right or right to left).
- Executing a U-turn (where the 4-H'er goes around the dog) is a major fault.

Switching Hands

It may be necessary in some patterns to switch the lead from one hand to the other to ensure the dog is always between the judge and the handler. These changes should be done gracefully at the corners of the patterns only as necessary to be sure the judge has an unobstructed view of the dog.

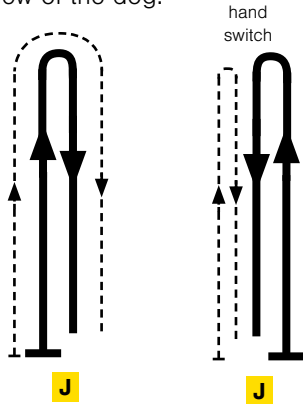

Completion of the Pattern

It is customary for the 4-H'er to stop a few steps back from the judge. Some judges will use a hand signal to designate when to stop, others may not.

If a judge does not signal, be sure to stop 6 feet from the judge. Most breeds should stop and stand with all four feet square. This is called "free stacking." The dog should walk into the stack squarely, without the handler moving the dog's feet by hand. It is encouraged to show off the dog's best physical attribute, such as a happy alert expression, proper head for the breed, body confirmation for the dogs, etc., by a front or side presentation of the dog to the judge. This can show the 4-H'er's additional knowledge of showmanship. Using hands to stack the dog upon the completion of an individual pattern is considered a major fault.

Stacking

Stacking dogs should be done when the class stops gaitting around the ring. It should be maintained while the judge is doing individual examinations of other dogs in the class. The exception would be that occasionally the judge may give direction "to relax your dog" due to large class size, etc. This means that it is ok for the dog to sit or lie down; HOWEVER, the 4-H'er must remain attentive to both the judge and his/her dog's needs.

In the 4-H showmanship ring, handlers whose breed of dog is customarily shown in the AKC ring on a table may stack their dog on the floor or may request a table.

When stacking the dog, it is acceptable for the handler to either kneel on one or both knees or stand depending on individual preference and comfort level. Minor deductions

shall be made for any 4-H'er who is not able to move gracefully and quickly around the dog. Major deductions shall be made for crawling on both knees.

4-H'ers may lift from underneath the chest or mandible and hips to stack their dog.

- Never use the tail to stack the dog (as is done with some breeds in the AKC ring). It is considered a major fault to use the tail to stack a dog.
- Never lift all four feet of the dog off the floor at the same time. It is considered a major fault to lift all four feet of the dog off the floor at the same time.

Table stacking guidelines

Lift the dog to the table so that the hindquarters of the dog approach the table first. This may help the dog to correctly position the front feet at the edge of the table. It is considered a major fault to lift the dog to the table by the tail (as done with some breeds in the AKC ring). Free stacking is walking the dog into the proper stack and keeping his/her attention. The breeds that are stacked square are the easiest to work with and look the best free stacked.

As the judge moves to various locations in the ring, it is important that the 4-H'er keep the dog between himself/herself and the judge. The handler should not at any time block the view of the dog from the judge (hands on tail, hands over muzzle, etc.). It is acceptable for him/her to stack the dog by reaching over the dog to position the feet furthest from him/her. For safety reasons, under no circumstances may a judge leave the ring in order to make the handlers switch sides. If a judge wants to observe the group switching sides, they should move the "line up" to the diagonal.

It is each member's responsibility to find out how their breed is customarily stacked. For specific information on stacking, see the "Proper Breed Presentation" section of this book. While stacking the dog, handlers will be evaluated on the correct stack for the breed. All breeds are stacked with their front feet positioned evenly with each other.

It is each handler's responsibility to leave sufficient space between themselves and the dog in front of them. Sufficient space means there is enough room for the judge to walk between the dogs without touching either dog or feeling crowded.

4-H'ers should work to develop proficiency in speed and ease of stacking. To begin learning this process, begin by practicing walking the dog into a stack until the dog will automatically place its front feet squarely.

The judge may request that 4-H'ers move to a different location in the ring or restack their dog facing another direction. When this occurs, it is important to be able to turn the dog gracefully and to re-stack the dog quickly.

Individual Examination of the Dog

Individual examinations of each dog will be conducted, usually from the group stack. The judge may look at the dog from a few steps back and then move forward to examine the dog. While the judge is doing this, the 4-H'er should be attentive to the judge while maintaining full control over the dog.

When preparing for the individual exam, the 4-H'er may slide their left hand into the collar and wrap their hand around the dog's jaw/head as best as they can, for increased control of the dog during their exam. The dog should be held firmly, not tightly. The lead may be dropped during this time only, without deduction.

Some judges may ask the handler to show either the dog's bite or their teeth. To show the bite, lift the front lips of the dog to show how the teeth come together. To show the teeth, lift the side lip and expose the side teeth. The judge will be looking for cleanliness. 4-H'ers should be careful not to get his/her hands or head in the way of the judge's view.

If the judge moves off-side, the 4-H'er should move, so the dog stays between the handler and the judge, while keeping the dog under control. The handler should remain on the off-side as no judge should cross behind a handler. (The recommendation is that the handler step back from the dog remaining on the off side but still allowing the judge to view the entire side view of the dog's off side).

4-H'ers Handling Skills

Handlers should appear prepared, confident and attentive. They should be courteous to both the judge and fellow exhibitors. Handlers are expected to handle their dogs without distracting other 4-H'ers or their dogs. Those who crowd or disturb other dogs must be faulted.

Handlers should be aware that judges will excuse any dog that: (1) is out of control, (2) injured (healed injuries that do not cause the dog pain are excluded), or (3) shows aggression toward other dogs or people. If there is any question about an injury and the ability of a dog to be shown, the 4-H'er should plan ahead and provide the show committee and the judge with a document from a licensed, practicing veterinarian that states that it is okay for the dog to be shown. Those who exhibit impatience or mistreatment of their dogs will be faulted.

Posture

- While gaiting, the handler's back should be straight, head up and watching where he/she is going.
- If choosing to kneel while stacking, try to keep the body straight and use the legs to raise and lower oneself to the dog's level. When showing large breeds, bend at the waist only when necessary and as quickly and smoothly as possible.

Smoothness

- In the ring remain calm, cool and collected. Remember not to rush.
- All actions should be smooth, controlled and purposeful. Jumpy and jerky actions make one appear nervous and unsure.

Attentiveness

- Look confident. Remember to smile and enjoy the show.
- It is NOT appropriate to talk to other exhibitors or spectators. One's attention should always be focused on what is happening in the ring, including the dog, the judge and other exhibitors.
- Know where the judge is located and always keep the dog visible to the judge.
- While gaiting, it is appropriate to make occasional eye contact with the judge. Eye contact should be subtle and natural. It should not be forced nor look "fake."
- It is important to listen to the judge's instructions. If unsure of an instruction, it is appropriate to ask the judge for clarification.

Sportsmanship

- Think positively when entering the show ring.
- No matter the placing, be humble and gracious. It is appropriate to sincerely congratulate the class winners. In a like fashion, class winners should accept congratulations from others graciously.
- If the judge provides feedback, listen attentively and thank him or her.
- It is courteous to express personal appreciation to those who are involved with the show including show committee members, 4-H staff and volunteers, judges, award donors, etc.

While competing, 4-H'ers should remember that the judge will consider the following questions:

1. Is the dog responsive to the handler? Do they work as a team?
2. Does the dog appear stacked or interested at all times?
3. Is the dog under control?

4. Is the dog gaited correctly to the best of its ability?
5. Do both the dog and 4-H'er appear relaxed?
6. Is the dog presented with an economy of motion that gives the appearance of ease and minimum effort used to present the dog?

Judging the Competition

- Judges should evaluate the general conduct of the 4-H members in the showmanship ring.
- When judging 4-H showmanship classes, judges shall utilize patterns and procedures outlined in the South Dakota 4-H Dog Showmanship Rulebook.
- Each judge may vary their routine from class to class. Within a class, judges must be consistent in the initial examination of each handler, using the same individual gaiting patterns, the same procedural requests, and allowing approximately the same amount of time for each handler. More challenging variations may be used as tie-breakers, call-backs or the final judging of a class.
- It is suggested that the judges ask the questions either at the time of the examination of the dog, or after the handler and dog do their individual pattern. Once a question is posed, the judge should do it the same way the whole day of judging.
- Under no circumstances should a 4-H judge ever ask two handlers to complete the down and back pattern (side by side) at the same time.
- The 4-H judge shall be inside the ring at all times when judging. At no time shall the judge ask the handler to perform any gaiting patterns with the judge on the outside of the ring.
- A main principal of 4-H Showmanship is to learn the spirit of competition. Judges shall be aware of sportsmanship in the ring and serious deductions shall be made for deliberate rudeness or unsportsmanlike conduct. Winning is important but secondary to the development of sportsmanship during competition. Judges who reward unsportsmanlike conduct or action compromise the very premise of 4-H! The South Dakota 4-H Dog project uses the American Kennel Club (AKC) categorized dog breeds as a guide for the eight dog groups. They are: Sporting, Hound, Working, Terrier, Toy, Non-Sporting, Herding and Miscellaneous.

Proper breed presentation

A mixed breed dog should be shown by the breed standard it most closely resembles, even if it is not a cross of that breed. The South Dakota 4-H Dog project uses the AKC and UKC standard breeds as guides for each dog's breed.

When the judge asks a 4-H'er what breed he/she is showing the dog as, he/she should reply with the breed's proper name. For example: say "Shetland Sheepdog" rather than "Sheltie."

The following guidelines apply to all breeds:

- If the tail of the breed being shown is supposed to be up, and stays up, it is better if the handler leaves it alone.
- The South Dakota 4-H Dog Project recognizes that many dogs in 4-H competition may not measure up to breed standards, especially around tail carriage. Many dogs may have low tail sets and some high tail sets, which makes it fairly difficult to make the tail "an extension of the topline." In those cases, 4-H'ers should present the tail to the best of their ability, but not "crank" the tail over the dog's back.
- In all breeds, when the stacking guidelines mention that the rear legs should be stretched out, it is important to consider the dog's structure. If a dog is not structurally able to stretch out it's rear legs, the 4-H'er should do the best he/she can to present the best overall picture.
- In all breeds, when the gaiting guidelines mention gaiting speed, dogs will be shown at a trot. This means that the dog is trotting but the dog is always under control. The 4-H'er needs to move at a speed that will match the dog's appropriate gait.
- There is no set speed to gait any breed, it is at the speed the dogs look best.

Showmanship Knowledge Questions

In competitive 4-H showmanship classes, judges may ask questions as a tiebreaker among top handlers. Each handler should be prepared to answer questions related to the current year's Dog Skillathon stations [see [skillathon study guide](#) on the SDSU Extension website] as well as specific questions about your dog. All youth are encouraged to participate in the Dog Skillathon (where offered) to demonstrate their knowledge.