

INDUSTRY MODERNIZED

FACTORY SPACES FOR THE FUTURE

**STANDARD
PRODUCT
OVERVIEW**

BUILT
SYSTEMS



BUILT FOR PEOPLE.

At BUILT Systems, we understand that it's the people that make our work, and yours, possible. It's the people on the lines each day; it's the people behind the scenes. Your outcomes, the trackable metrics, the sales, and success, happen because of the men and women in your facilities.

That's why every product here at BUILT Systems was created with them in mind. Whether it's the ergonomic features, the long-lasting durability, or the flexible modularity, it was designed for your business' success and **BUILT FOR PEOPLE.**

WORKSTATIONS	6
MACHINE BASES	12
WELDING PRODUCTS	16
ORGANIZATIONAL PRODUCTS	20
MATERIAL HANDLING PRODUCTS	24
SMART SOLUTIONS	28
BUILD YOUR OWN	32



PLANNING FOR PRODUCTION

Are you expanding your building, looking to change layouts for efficiencies, or starting a new manufacturing business?

BUILT Systems is here to be your one-stop-shop to outfit your production floor. Our team designed each product determined to solve for every considerable objective as you plan: from safety, flow of material, staff health and comfort, organization, accessibility of equipment, efficient use of space, and future expansions.

Why source your manufacturing needs from multiple companies when BUILT Systems can provide all you need in one place? Top-of-the-line quality for modular, versatile, and durable products shipped fully-assembled. Take a look at what we can offer.

WORKSTATIONS



BUILT's line of light- to heavy-duty Workstations is constructed with rigid, cold-rolled steel and uses a patented, electric height-adjustable system where applicable. Our Workstations are supported by heavy-duty casters and Mighty Mounts so that your production lines are as tough as the work you do.

Create your own by selecting the add ons and work surface that you need, or order one of our Pre-Configured Solutions.

WORKSTATIONS

LIGHT-DUTY

PEDESTAL BASE

LIGHT-DUTY
HEIGHT-ADJUSTABLE WORKSTATION

Lift capacity 150 lbs



Available with electric or crank height-adjustment.



No Lightframe

With Lightframe

ATE150

LIGHT-DUTY
HEIGHT-ADJUSTABLE WORKSTATION

Lift capacity 150 lbs

Shown with Lightframe, Upper Shelf, Tool Bin Bracket, and Drawer



Available with electric or crank height-adjustment.



WORKSTATIONS

MEDIUM-DUTY

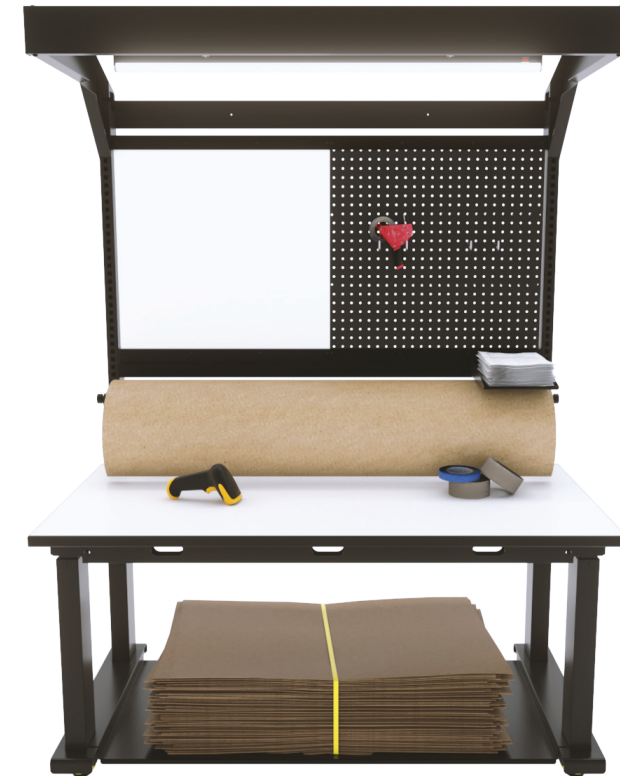

ATE400

MEDIUM-DUTY
HEIGHT-ADJUSTABLE WORKSTATION

Lift capacity 400 lbs

Shown with Lightframe, Whiteboard/ Pegboard Combo, Tool Bin Bracket, Paper Tray, Roll Holder, and Lower Shelf



No Lightframe

With Lightframe



Available with electric height-adjustment only.

BUILD YOUR OWN WORKSTATION!

See the end of this guide for Add-Ons and Work Surface options.

WORKSTATIONS

HEAVY-DUTY



WKB1000

HEAVY-DUTY
HEIGHT-ADJUSTABLE WORKSTATION

Lift capacity 1000 lbs

*Shown with Lightframe, Pegboard,
Fan Kit, and Tool Bin Ergo Arm*



No Lightframe



With Lightframe



Available with electric
height-adjustment only.

WORKSTATIONS

HEAVY-DUTY



WKB3000

HEAVY-DUTY
HEIGHT-ADJUSTABLE WORKSTATION

Lift capacity 3000 lbs

*Shown with Lightframe, Tool Trolley +
Balancer, Monitor Mount, Fan Kit,
and Parts Bin*

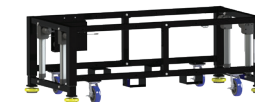

No Lightframe



With Lightframe



Available with electric
height-adjustment only.

BUILD YOUR OWN WORKSTATION!

See the end of this guide for Add-Ons
and Work Surface options.

MACHINE BASES



BUILT's line of Machine Bases are constructed with rigid, cold-rolled steel using our patented electric height-adjustable system. Heavy-duty casters, Mighty Mounts and bolt-to-floor anchors provide a strong foundation for your machines and allow you to set your factory layout in a modular or permanent setup.

Build upon your machine base by selecting the work surface you need, or order one of our Pre-Configured Solutions.

MACHINE BASES

LIGHT to MEDIUM-DUTY



MB800
LIGHT-DUTY
HEIGHT-ADJUSTABLE MACHINE BASE
Lift capacity 800 lbs

MACHINE BASES

HEAVY-DUTY

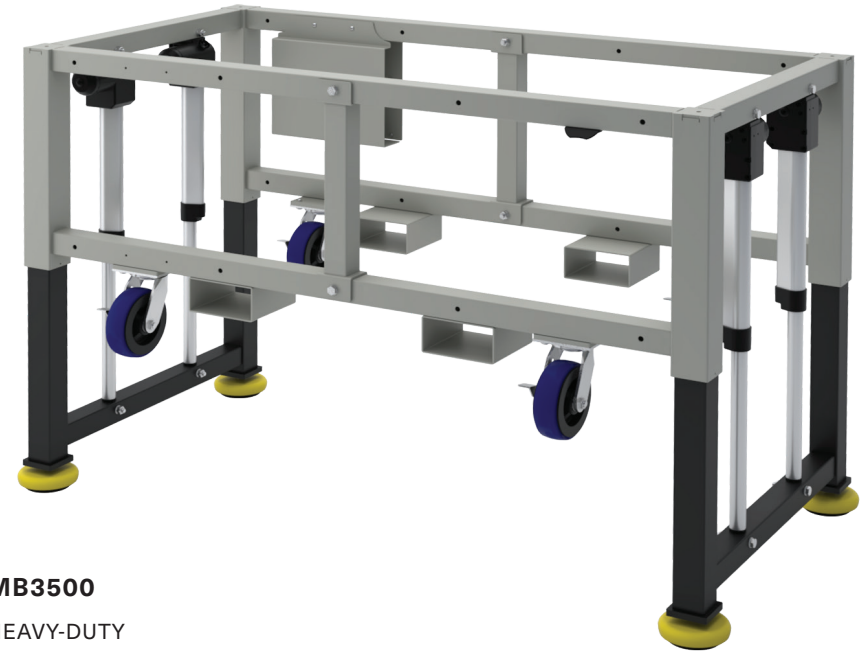

MB3500
HEAVY-DUTY
HEIGHT-ADJUSTABLE MACHINE BASE
Lift capacity 3500 lbs



MB1200
MEDIUM-DUTY
HEIGHT-ADJUSTABLE MACHINE BASE
Lift capacity 1200 lbs

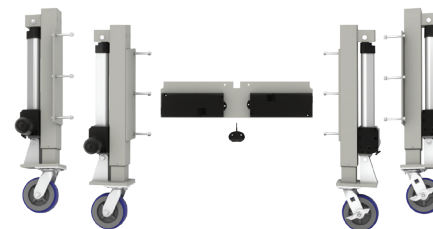

RETRO-FIT YOUR OWN!

Turn your existing fixed height table into a height-adjustable machine base.

Lift capacity 1500 lbs

*Available with Mighty Mounts or casters.
Contact us for full list of options.*

WELDING PRODUCTS



BUILT's Welding Products are designed ergonomically for the user's safety and convenience with high-performance actuators to raise and lower loads at the touch of a button. Each weld table is equipped with an anti-corrosion, anti-splatter worksurface.

For complete, efficient 5S methodology implementation, pair a weld table with a BUILT Systems Mobile Tool Cart.

WELDING PRODUCTS

WT1000
HEIGHT-ADJUSTABLE WELD TABLE
Lift capacity 1000 lbs



WT6000
HEIGHT-ADJUSTABLE WELD TABLE
Lift capacity 6000 lbs



WT3000
HEIGHT-ADJUSTABLE WELD TABLE
Lift capacity 3000 lbs

MOBILE TOOL CART



ORGANIZATIONAL PRODUCTS



Organizational Products from BUILT Systems are designed with the same industrial standards that every BUILT product offers, perfect for your manufacturing, shipping, and assembly environments. Utilize these solutions to practice LEAN by posting data and visuals for full teams of employees to see.

ORGANIZATIONAL PRODUCTS



MOBILE WHITEBOARDS

STANDARD-DUTY WHITEBOARD

Two-sided writing surface



ANYWHERE TABLE

LIGHT-DUTY
FIXED-HEIGHT WORKSTATION

Load capacity 250 lbs



HD MOBILE WHITEBOARDS

HEAVY-DUTY WHITEBOARD

Two-sided writing surface



POWER TOOL CART



5S CLEANING CART

MATERIAL HANDLING PRODUCTS



BUILT's line of Material Handling Products provide innovative, reliable ways to move parts from cell to cell in your lean manufacturing environment. Choose from a variety of carts and conveyors, or customize your own solution, to perfectly complement assembly and welding tables, workbenches, and machine bases.

Each material handling solution features ergonomics, versatility, and durability to maximize your employee wellbeing and company ROI.

MATERIAL HANDLING

FLAT MATERIAL HANDLING CART

Load capacity 500 lbs



ELECTRIC TILT CART

Load capacity 1500 lbs



MATERIAL HANDLING CART

Load capacity 500 lbs

GAS-ASSIST TILT CART

Load capacity 500 lbs

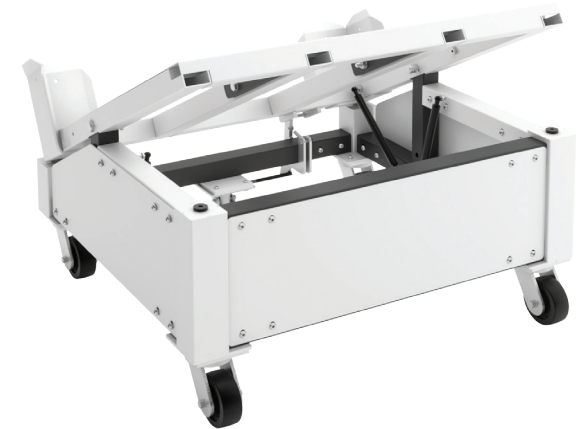

PALLET DOLLY

Load capacity 1000 lbs



FLOW RACK CART

Load capacity 1250 lbs
(250 lbs per shelf)



CONVEYORS

HEAVY-DUTY
HEIGHT-ADJUSTABLE CONVEYOR
Load capacity 1200 lbs

LIGHT-DUTY
HEIGHT-ADJUSTABLE CONVEYOR
Load capacity 150 lbs



SmartSolutions are the future of the industry. These products comprise of the trusted BUILT quality, durability, and modularity paired with new technology and automation; experience more efficiency and capacity with these customizable solutions.

Opportunities include interchangeable tooling, data collection, automated material handling, and more.

POWERED CONVEYORS

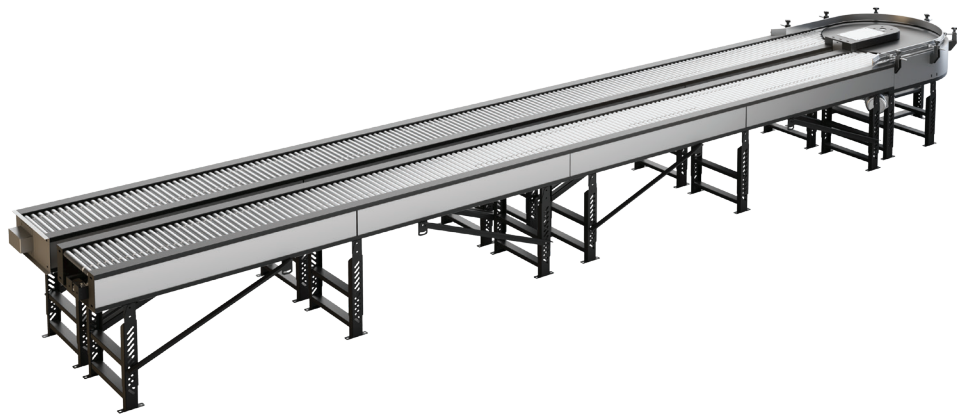

VIRTUAL WORKSTATION
Lift capacity 400 lbs

**AUTOMATED GUIDED
CARTS**

Tow capacity 2000 lbs







BUILD-YOUR-OWN

COLORS

STANDARD

-  RAL 9003 - Signal White
-  RAL 7037 - Dusty Grey
-  OB07 - Matte Black

SURFACES

-  Solid Maple Butcher Block
-  High Pressure Laminate Black*
-  High Pressure Laminate White*
-  Stainless Steel Wrap (16 ga.)
-  Steel (1/4")**

*High Pressure Laminate with electrostatic discharge (ESD) coating available.

**Heavier gauge steel available.



WORKSTATION ADD-ONS

Our add-ons allow you to configure your products to become tailored solutions specific to your needs and industry. Whether it is a packing station, a general assembly station, or something unique to your facility, BUILT's add-ons make each workstation truly your own.

UPPER ADD ONS

(requires lightframe)

- | | | |
|---|--------------------------|-------------------|
| LED Light | Upper Flow Rack Shelf | Basic Monitor Arm |
| Fan Kit | Tool Bin Bracket | Ergo Arm |
| Pegboard Kit | Upper Shelf (12" or 24") | Tray |
| Whiteboard Kit | Paper Tray | Single Monitor |
| Whiteboard/Pegboard Kit | Parts Bin | Dual Monitor |
| Tool Trolley
<small>available with Tool Balancer</small> | Small PC Hanger | Monitor/Keyboard |
| Roll Holder | Monitor Mount | Keyboard Only |
| | | Tool Bins |

LOWER ADD ONS

(lightframe not required)

- Drawer Kits
Large, Small or Combo
- Lower Shelf
- Lower Pegboard
- PC Tower Hanger
- Power Strip

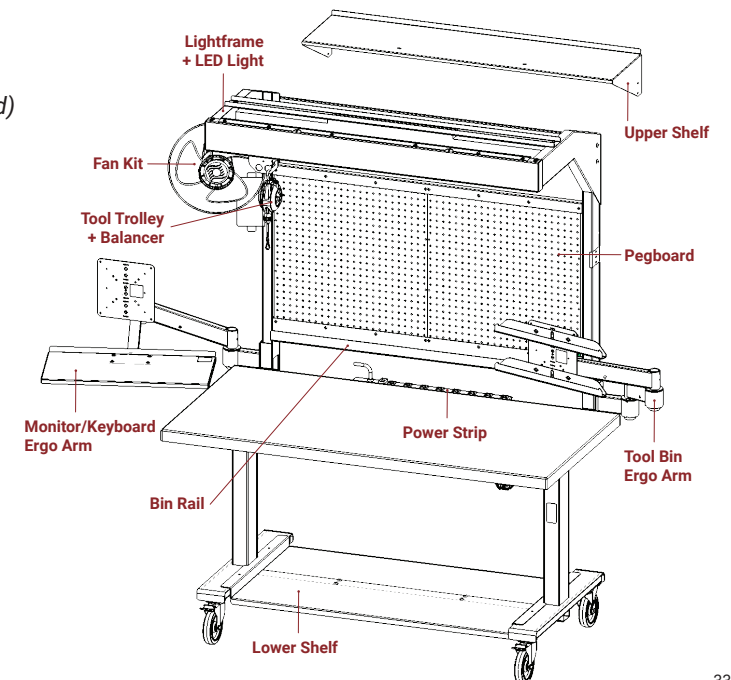

NEED A PRODUCT DEMO?

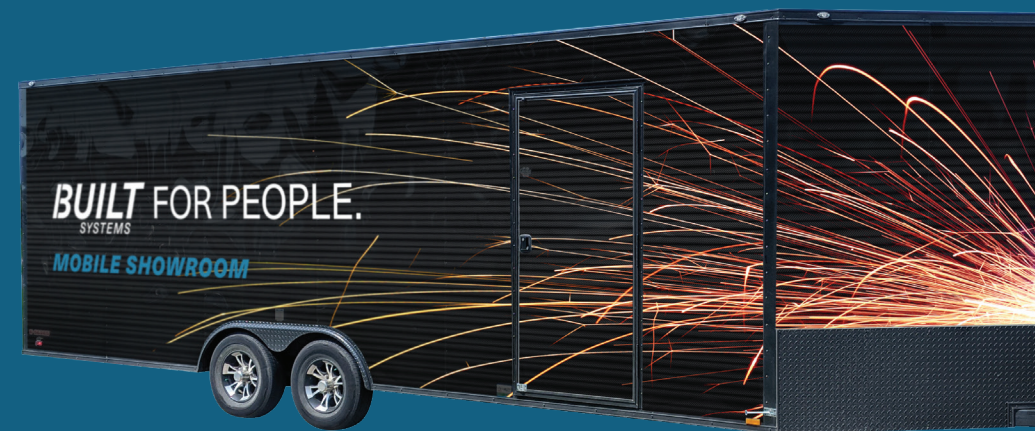

Book a visit from our Mobile Showroom.

Register at info@builtsystems.net
or give us a call at **616-795-4569**.



BUILT SYSTEMS | PRODUCT OVERVIEW