

E-FLOAT HOIST™

FEATURING ADVANCED DRIVETRAIN SYSTEM



Elevate Your Workflow with Precision Lifting and Intelligent Control

Knight's E-Float Hoist™ is a high-performance servo hoist designed for flexible and efficient material handling. It includes Knight's intuitive Float Mode without requiring an inline load cell. Its design is very low-profile, reducing stack-up and making it an ideal solution for environments where space is limited. The hoist supports a maximum lifting capacity of up to 300 lbs. (chain).

E-Float Hoist™ offers flexible options: with or without I/O, cable or chain lift, and a choice of three optional control handles. Please specify handle preference when ordering.



Cable or Chain



Analog Remote Pendant Handle (KCA1213)

- Rocker style for E-Float Hoists
- OCI with 19-Pin Male Receptacle



Analog Remote Pendant Handle (KCA1214)

- Dual Switch
- Paddle style for E-Float Hoists
- OCI with 19-Pin Male Receptacle



Inline Handle (KLCA1080)

- Enable lever and Swivel Top Hat for 150# & 300# E-Float Hoists

* Standard E-Float Hoist™ does not come with a handle, please specify handle when ordering.

	Model Number	Max. Capacity	Max. Speed	I/O Capabilities
CABLE	KSBA150-80-S-2401-002	150 lbs. [68 kg]	241 fpm. [73.5 mpm]	NO
	KSBA150-80-P-2401-002	150 lbs. [68 kg]	241 fpm. [73.5 mpm]	YES
CHAIN	KSBC150-80-S-2401-002	150 lbs. [68 kg]	241 fpm. [73.5 mpm]	NO
	KSBC150-80-P-2401-002	150 lbs. [68 kg]	241 fpm. [73.5 mpm]	YES
	KSBC300-80-S-2401-002	300 lbs. [136 kg]	241 fpm. [73.5 mpm]	NO
	KSBC300-80-P-2401-002	300 lbs. [136 kg]	241 fpm. [73.5 mpm]	YES



SPECIFICATIONS & FEATURES

- **Low Profile:** Reduced stack-up height compared to standard servo hoist.
- **Float Mode:** Enables operators to manually guide the load with minimal resistance, offering a natural “hands-on” feel for precise positioning and alignment.

For manufacturing cells or plants who prefer or require electrical over pneumatic, the E-Float Hoist™ can replace any application that would require a pneumatic balancer.
- **Interface:** Enhanced User Interface (UI) through Knight Servo Studio.

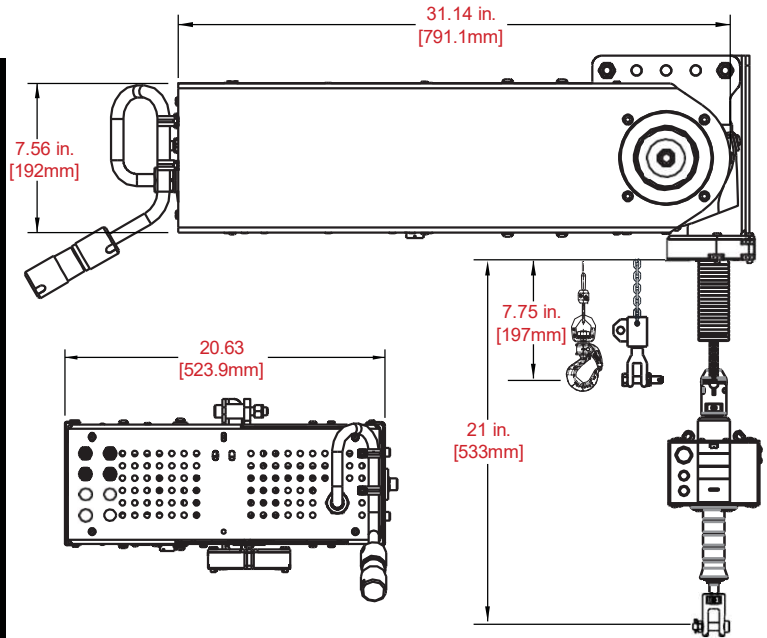

E-FLOAT HOIST™

MECHANICAL

- Low Profile – reduced stack-up height.
- Available with Cable or Chain.
 - Standard Cable: includes Hook with Bail and Locking Gate attachment (**BPA2020**).
 - Standard Chain: includes Safety Chain Shackle attachment (**BPA2410**).
- Holding Brake.
- Chain / Cable Travel Length – 80 in. Standard.
- Standard Chain / Cable length supplied is 12 feet. Longer lengths can be ordered upon request.
- Meets and exceeds industry standards.
- H5 Rated (Continuous Duty Cycle).
- Modular design for quick maintenance (including cable / chain replacement).
- CE and UL compliant.
- Speed – up to 241 fpm. [73.5 mpm] or 50 ips. [1.27 m/s].
- Maximum Lifting Capacity – up to 300lbs. [136 kg.] for 300 lb. model/up to 150 lbs. [68 kg.] for 150 lb. model.

ELECTRICAL

- Load Sensing.
- 240-Volt operation.
- LED Status Indicators: Green and Blue
- Lighted Push Buttons.
- LED Fault Indicators: Illuminated Run / Stop.

SOFTWARE

- Auto-Balance Mode up to 300 lbs. [136 kg.] for 300 lb. model/up to 150 lbs. [68 kg.] for 150 lb. model.
- STO – Safe Torque Off.
- Enhanced User Interface (UI).
- Ethernet Connection.
- Programming / Diagnostic Communication port.
- Speed Reduction Zones.
- Impact Limiting.
- Active Damping.
- Knight’s Unique “Float” Mode.
- Programmable Overload Capability.
- Advanced Diagnostics and Fault Monitoring.

OPTIONAL

- Control Handles:
 - Analog Remote Pendant Handle, Rocker Style for E-Float Hoists, OCI with 19-Pin Male Receptacle (**KCA1213**)
 - Analog Remote Pendant Handle, Dual Switch, Paddle Style for E-Float Hoists, OCI with 19-Pin Male Receptacle (**KCA1214**).
 - Inline Handle with Enable Lever & Swivel Top Hat for 150# & 300# E-Float Hoists (**KLCA1080**).
- Wireless Remote Pendant.
- Fixture Handle.
- Balancer Chain Hook (**BPA2113**).
- Custom Programming for End Users’ Specific Needs.**
- Industry Standard 24 VDC, 2 AMP power available for custom tooling:
 - Clamps, Vacuum Cups, Switches, Proximity Lights, etc.
- I/O Capabilities:**
 - (4) Analog Inputs / (4) Analog Outputs.
 - (24) Sourcing Inputs or Outputs, configurable.
 - (8) Dedicated Inputs / Outputs.
 - Expansion I/O: Ethernet, unlimited.

** Features available with E-FLOAT HOIST+™ only.