

25Gbps SFP28 SR Optical Transceiver

Product Features

- Operating data rate up to 25.78Gbps
- 850nm VCSEL Transmitter
- Distance up to 100m @50 / 125 um OM4
- Distance up to 70m @50 / 125 um OM3
- Single 3.3V Power supply
- Duplex LC Connector Interface, Hot Pluggable
- Built-in dual CDR
- Electrical interface compliant to SFF-8431
- Power Dissipation < 1.0W
- Operating Case Temperature Standard: 0°C~+70°C

The Axiom 25GBASE-SR SFP28 module is designed for duplex optical data and communications up to 25.78Gb/s. It is with the SFP+ 20-pin connector to allow hot plug capability, Digital diagnostic functions are available via an I2C. It has built-in clock and data recovery (CDR). This module is designed for multi-mode fiber and operates at a nominal wavelength of 850 nm. The transmitter section uses a Vertical Cavity Surface Emitted Laser (VCSEL) and is a Class 1, laser compliant according to International Safety Standard IEC 60825. The receiver section uses, an integrated GaAs detector preamplifier (IDP) mounted in an optical header and a limiting post-amplifier IC.

Regulatory Compliance

Feature	Standard	Performance
Electromagnetic Interference (EMI)	FCC Part 15 Class B EN 55022:2010, Class B	Compatible with standards
Electromagnetic susceptibility (EMS)	EN 55024:2010	Compatible with standards
Laser Eye Safety	FDA 21CFR 1040.10 and 1040.11 EN60950, EN (IEC) 60825-1,2	Compatible with Class I laser product

Applications

- 25GBASE-SR

Absolute Maximum Ratings

The operation in excess of any absolute maximum ratings might cause permanent damage to this module.

Parameter	Symbol	Min	Max	Unit	Notes
Storage Temperature	TS	-40	85	°C	
Operating Case Temperature	TOP	0	70	°C	
Power Supply Voltage	V _{CC}	-0.5	3.6	V	
Relative Humidity (non-condensation)	RH	5	85	%	

Recommended Operating Conditions and Power Supply Requirements

Parameter	Symbol	Min	Typical	Max	Unit	Notes
Operating Case Temperature	TOP	0		70	degC	
Power Supply Voltage	VCC	3.135	3.3	3.465	V	
Data Rate,				25.78125	Gb/s	
Data Rate Accuracy		-100		100	ppm	
Tx_DISABLE Input Voltage –High		2			V	
Tx_DISABLE Input Voltage – Low				0.8	V	
50 / 125 um MMF OM3	D	2		70	m	
50 / 125 um MMF OM4	D	2		100	m	

Optical Characteristics

All parameters are specified under the recommended operating conditions unless otherwise specified..

Parameter	Symbol	Min	Typical	Max	Unit	Notes
Power Consumption				1.0	W	
Supply Current	I _{cc}			300	mA	
Transmitter						
Centre Wavelength	λ_C	840	850	860	nm	
Spectral Width (RMS)@25Gb/s	$\Delta\lambda$	8.2		0.6	nm	
Average Output Power: 50 MMF	P _{out}	-8.4		2.4	dBm	
Extinction Ratio	ER	2			dB	
Receiver						
Centre Wavelength	λ_C	840	850	860	nm	
Receiver Sensitivity(OMA)	S _{min}			-8.4	dBm	
Average Receiver Power	P _{in}	-10.3		3	dBm	
Optical Return Loss	ORL			-12	At 1MHz	
LOS De-Assert	LOSD			-13	dB	
LOS Assert	LOSA	-30			dB	
LOS Hysteresis		0.5			dB	

Digital Diagnostic Functions

Digital diagnostics monitoring function is available on Axiom 25GBASE-SR SFP28 products. A 2-wire serial interface provides user to contact with module. It is compliant to SFF-8472 Rev10.2 with internal calibration mode. For external calibration mode please contact our sales staff.

Parameter	Symbol	Min	Max	Unit	Notes
Temperature monitor absolute error	DMI_Temp	-3	+3	°C	
Supply voltage monitor absolute error	DMI_VCC	-0.1	+0.1	V	
TX power monitor absolute error	DMI_RX	-3	+3	dB	
RX power monitor absolute error	DMI_RX	-3	+3	dB	
Bias current monitor	DMI_Ibias	-10%	+10%	mA	

Recommended Circuit

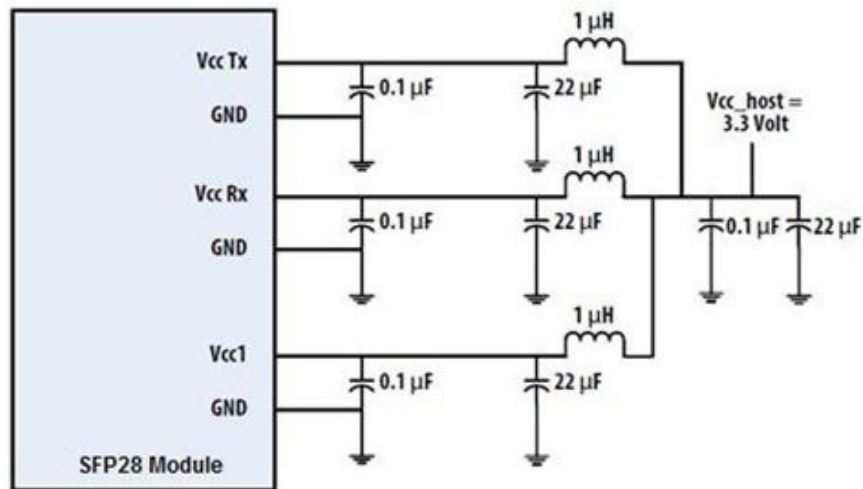

Mechanical Dimensions

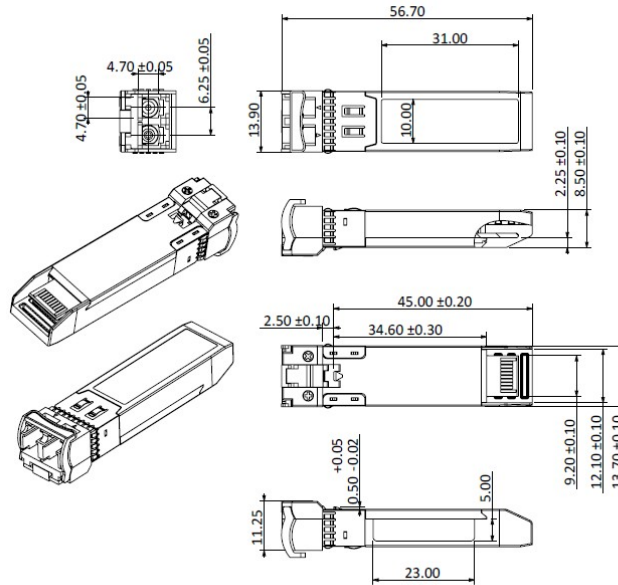

(Unit: mm [inch])

Pin Assignment and Description

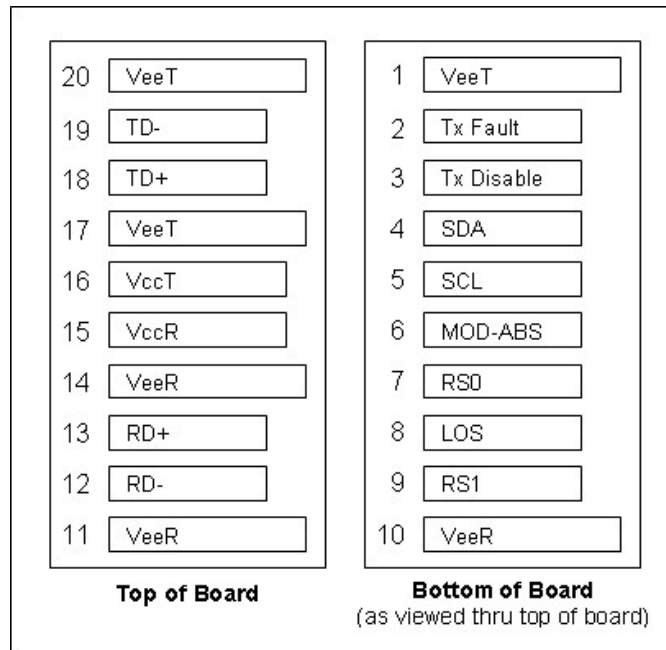

Pin Assignment

PIN #	Symbol	Description	Notes
1	VeeT	Transmitter Ground	
2	TX Fault	Transmitter Fault Indication	Note 1
3	TX Disable	Transmitter Disable	Note 2, Module disables on high or open
4	SDA	2-wire Serial Interface Data Line(Same as MOD-DEF2 in INF-8074i)	
5	SCL	2 Wire Serial Interface Data Line (Same as MOD-DEF1 as defined in the INF-8074i)	

6	MOD-ABS	Module Absent, Connected to VeeT or VeeR in the module.	Note 3
7	RS0	SFP+ RX Rate Select, optional	Rate Select0, Not used. Note 9
8	LOS	Loss of Signal	Note 4
9	RS1	SFP+ TX Rate Select, optional	Rate Select 1, Not used. Note 9
10	VeeR	Receiver Ground	Note 5
11	VeeR	Receiver Ground	Note 5
12	RD-	Inv. Received Data Out	Note 6
13	RD+	Received Data Out	Note 6
14	VeeR	Receiver Ground	Note 5
15	VccR	Receiver Power	Note 7, 3.3V \pm 5%
16	VccT	Transmitter Power	Note 7, 3.3V \pm 5%
17	VeeT	Transmitter Ground	Note 5
18	TD+	Transmit Data In	Note 8
19	TD-	Inv. Transmit Data In	Note 8
20	VeeT	Transmitter Ground	Note 5

Notes:

Plug Seq.: Pin engagement sequence during hot plugging.

1. TX Fault is an open collector/drain output, which should be pulled up with a 4.7K – 10K Ω resistor on the host board. Pull up voltage between 2.0V and VccT +0.3V. When high, output indicates a laser fault of some kind. Low indicates normal operation. In the low state, the output will be pulled to < 0.4V.
2. TX disable is an input that is used to shut down the transmitter optical output. It is pulled up within the module with a 4.7 – 10 K Ω resistor. Its states are:

Low (-0.3 – 0.8V):Transmitter on (>0.8, < 2.0V):Undefined

High (2.0 – VccT+0.3V):Transmitter Disabled Open:Transmitter Disabled
3. Mod-ABS shall be pulled up with a 4.7K – 10K Ω resistor on the host board. The pull -up voltage shall VccT or VccR.
4. LOS (Loss of Signal) is an open collector/ drain output, which should be pulled up with a 4.7K – 10K Ω resistor. Pull up voltage between 2.0V and VccR+0.3V. When high, this output indicates the received optical power is below the worst-case receiver sensitivity (as defined by the standard in use). Low indicates normal operation. In the low state, the output will be pulled to < 0.4V.
5. VeeR and VeeT may be internally connected within the SFP module.
6. RD-/+: These are the differential receiver outputs. They are AC coupled 100 Ω differential lines which should be terminated with 100 Ω (differential) at the user SERDES. The AC coupling is done inside the module and is thus not required on the host board.
7. VccR and VccT are the receiver and transmitter power supplies. They are defined as 3.3V 5% at the SFP connector pin. Maximum supply current is 300mA. Recommended host board power supply filtering is shown below. Inductors with DC resistance of less than 1 Ω should be used in order to maintain the required voltage at the SFP input pin with 3.3V supply voltage.

When the recommended supply filtering network is used, hot plugging of the SFP transceiver module will result in an inrush current of no more than 30 mA greater than the steady state value. VccR and VccT may be internally connected within the SFP transceiver module.
8. TD-/+: These are the differential transmitter inputs. They are AC -coupled, differential lines with 100 Ω differential termination inside the module. The AC coupling is done inside the module and is thus not required on the host board.
9. Internally pulled down per SFF-8431 Rev 4.1.