

1000Base 2CH Compact BiDi SFP Transceiver

Product Features

- Achieve operational compatibility with conventional SFP: Conventional SFP will function when plugged into a C-SFP socket. No damage to C-SFP and host board if C-SFP module is plugged into a conventional SFP socket
- 2-channel Bi-directional Optical Transceiver unit with
 - 1490nm DFB Laser diode transmitter
 - 1310nm InGaAs PIN photodiode receiver
- 2xBi-directional transceivers in 1 SFP transceiver package
- 20-pin electrical interface and LC receptacle ,With pull de-latch
- 1250Mbps Typical Data Rate and compliant to 1000Base IEEE802.3ah
- Comply with CSFP MSA Option 2
- Digital diagnostic monitoring
- Metal enclosure for lower EMI
- +3.3V Single power supply
- LVPECL logic interface simplifies interface to external circuitry
- 20 km reach with 9/125 μ m single mode fiber (SMF)
- Operation case temperature : 0 to 70° C
- Comply with RoHS directive (2002/95/EC)

Applications

- Gigabit Ethernet
- Point to Point FTTH Application

The optical transceiver is compliant with the Compact Small Form-Factor Pluggable (CSFP) Multi-Source Agreement (MSA) option 2.It offers previously unavailable system cost, upgrade, and reliability benefits by virtue of being hot-pluggable.

Ordering Information

Part Number	Description
AC-B-CSFPBX20-43-xx	1000Base 2CH Compact BiDi SFP Tx1490nm, Rx1310nm Transceiver 20km

Regulatory Compliance

Feature	Standard	Performance
Electromagnetic Interference (EMI)	FCC Part 15 Class B EN 55022:2010, Class B	Compatible with standards
Electromagnetic susceptibility (EMS)	EN 55024:2010	Compatible with standards
Laser Eye Safety	FDA 21CFR 1040.10 and 1040.11 EN60950, EN (IEC) 60825-1,2	Compatible with Class I laser product

Absolute Maximum Ratings

The operation in excess of any absolute maximum ratings might cause permanent damage to this module.

Parameter	Symbol	Min	Max	Unit	Notes
Storage Temperature	TS	-40	85	°C	
Operating Case Temperature	TOP	0	70	°C	
Power Supply Voltage	V _{CC}	-0.5	4.0	V	
Relative Humidity (non-condensation)	RH	0	85	%	
Damage Threshold for Receiver			3	dBm	-

Recommended Operating Conditions and Power Supply Requirements

Parameter	Symbol	Min	Typical	Max	Unit	Notes
Operating Case Temperature	TOP	0		70	°C	
Power Supply Voltage	V _{CC}	3.135	3.3	3.465	V	
Power Consumption			1.2	1.3	W	
Total Supply Current	I _{CC}			400	mA	

Optical Characteristics

All parameters are specified under the recommended operating conditions unless otherwise specified..

Parameter	Symbol	Min	Typical	Max	Unit	Notes
Transmitter						
Center Wavelength	λ	1480	1490	1500	nm	-
Side Mode Suppression Ratio	SMSR	30	-	-	dB	-
Spectral Width (-20dB)	Δλ	-	-	1	nm	-
Average Optical Output Power	Po	-9	-	-3	dBm	-
Extinction Ratio	Er	6.0	-	-	dB	-
Average Launch Power of OFF Transmitter	Poff	-	-	-40	dBm	-
Transmitter Enable Voltage	VEN	-0.3	-	0.8	V	-
Transmitter Disable Voltage	VD	2.0	-	Vcc+0.3	V	-
Rise/Fall Time (20%~80%)	Tr/Tf	-	-	260	ps	-
Input Differential Impedance	ZIN	80	-	120	Ohm	-
Single Ended Data Input Swing	Vpp	250	-	1200	mV	-
Optical Eye	IEEE 802.3ah Compliant					1
Receiver						
Operate Wavelength	-	1260	1310	1360	nm	-
Sensitivity	Pr	-	-	-22.5	dBm	2
Saturation	Ps	-3	-	-	dBm	2
LOS Asserted	-	-44	-	-	dBm	High level:
LOS De-Asserted	-	-	-	-25	dBm	Alarm

LOS Hysteresis	-	0.5	-	5	dB	
Data Output Rise/Fall Time	Tr/Tf	-	-	300	ps	
Single Ended Data Output Swing	VPP	300	-	800	mV	-
LOS Low Voltage	VLout	-	-	0.4	V	-
LOS High Voltage	VHout	2.4	-	-	V	-

Notes:

1. Eye mask diagram with at least 10% margin
2. Minimum Sensitivity and saturation levels for a 27-1 NRZ PRBS. $BER \leq 10^{-10}$, 1.25Gpbs, ER=6dB.

Digital Diagnostic Functions

Parameter	Symbol	Min	Max	Unit	Notes
Temperature monitor absolute error	DMI_Temp	-3	+3	°C	
Supply voltage monitor absolute error	DMI_VCC	-0.1	+0.1	V	
TX power monitor absolute error	DMI_RX	-3	+3	dB	
RX power monitor absolute error	DMI_RX	-3	+3	dB	
Bias current monitor	DMI_ibias	-10%	+10%	mA	

Recommended Circuit

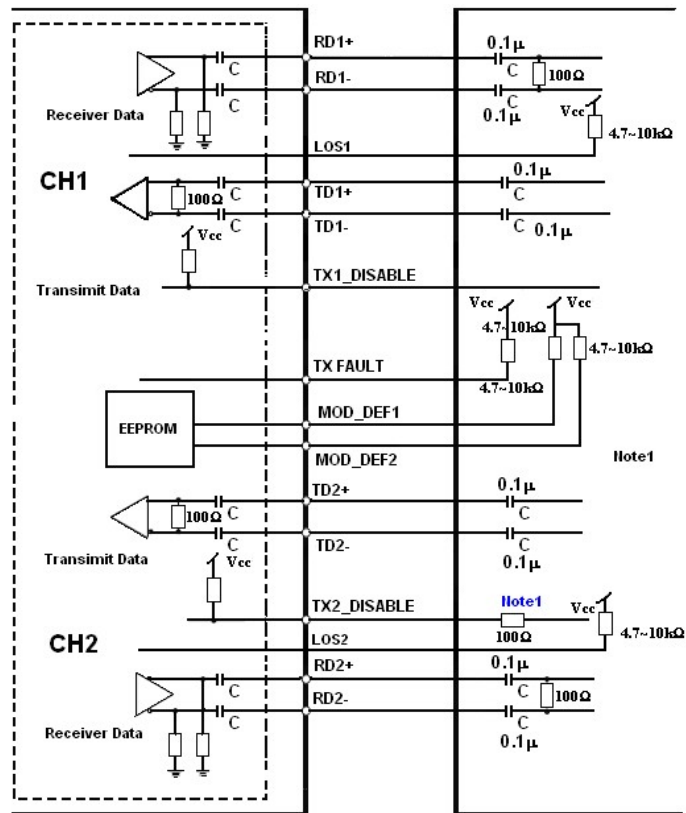

Mechanical Dimensions(Unit mm)

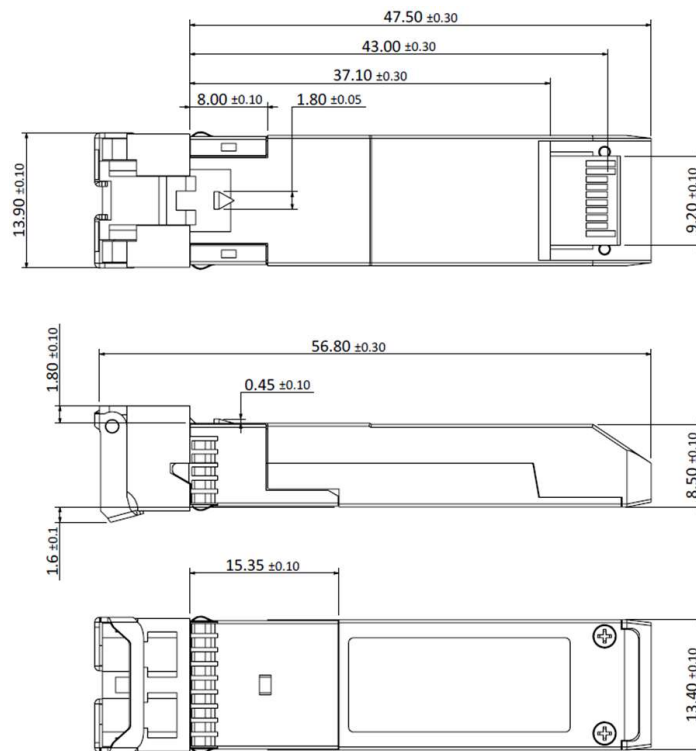

Pin Assignment and Description

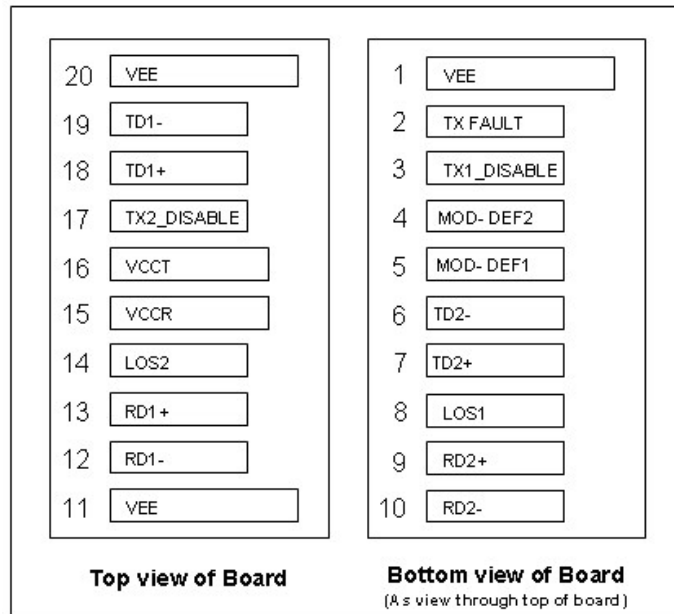

Pin Assignment

PIN #	Symbol		Description	Notes
1	VEE	Common	Transceiver Ground	Note 3
2	TX FAULT	Common	Transmitter Fault Indication	Note8
3	TX1_DISABLE	1	Transmitter Disable of Ch1	Note 1, Module disables on high or open
4	MOD-DEF2	Common	Two-wires interface Data	Note 2, 2 wire serial ID interface SDA

5	MOD- DEF1	Common	Two-wires interface Clock	Note 2, 2 wire serial ID interface SCL
6	TD2-	2	Inverted Transmit Data Input of Ch2	Note6
7	TD2+	2	Transmit Data Input of Ch2	Note6
8	LOS1	1	Loss of Signal of CH1	Note7
9	RD2+	2	Received Data Output of Ch2	Note 4
10	RD2-	2	Inverted Received Data Output of Ch2	Note 4
11	VEE	Common	Transceiver Ground	Note 3
12	RD1-	1	Inverted Received Data Output of Ch1	Note 4
13	RD1+	1	Received Data Output of Ch1	Note 4
14	LOS2	2	Loss of Signal of CH2	Note7
15	VCCR	Common	Receiver Power	Note 5,
16	VCCT	Common	Transmitter Power	Note 5,
17	TX2_DISABLE	2	Transmitter Disable of Ch2	Note 1, Module disables on high or open
18	TD1+	1	Transmit Data Input of Ch1	Note6
19	TD1-	1	Inverted Transmit Data Input of Ch1	Note6

20

VEE

Common

Transceiver Ground

Note 3

Notes:

1. TX_disable1, 2 are an input that is used to shut down the transmitter optical output. It is pulled up within the module with a 4.7 – 10 K Ω resistor. Its states are:

Low (0 – 0.8V): Transmitter on

(>0.8, < 2.0V): Undefined

High (2.0 – 3.47V): Transmitter Disabled Open: Transmitter Disabled

2. Mod-Def 1, 2. These are the module definition pins. They should be pulled up with a 4.7K – 10K Ω resistor on the host board. The pull-up voltage shall be VccT or VccR.

Mod-Def 1 is the clock line of two wire serial interfaces for serial ID Mod-Def 2 is the data line of two wire serial interface for serial ID

3. VEE may be internally connected within the SFP module.

4. RD1, 2-/+ : These are the differential receiver outputs. They are AC coupled 100 Ω differential lines which should be terminated with 100 Ω (differential) at the user SERDES. The AC coupling is done inside the module and is thus not required on the host board.

5. VccT,VccR are the power supplies. They are defined as 3.3V \pm 5% at the SFP connector pin. Maximum supply current is 450mA@3.3V. Vcc may be internally connected within the SFP transceiver module.

6. TD1, 2-/+ : These are the differential transmitter inputs. They are AC-coupled, differential lines with 100 Ω differential termination inside the module. The AC coupling is done inside the module and is thus not required on the host board.

7. LOS1,2 (Loss of Signal) is an open collector/drain output, which should be pulled up with a 4.7K – 10K Ω resistor. Pull up voltage between 2.0V and VccT, R+0.3V. When high, this output

indicates the received optical power is below the worst-case receiver sensitivity (as defined by

the standard in use). Low indicates normal operation. In the low state, the output will be pulled to < 0.4V.

8. TX Fault report transceiver status as following:

TX Fault is an open collector/drain output, which should be pulled up with a 4.7K – 10K Ω resistor on the host board. Pull up voltage between 2.0V and VccT, R+0.3V. When high, output indicates a laser fault of some kind either in Channel 1 or Channel 2. The Host shall read Channel 1/2: A2H/AAH: 110 for details: TX Fault from channel 1 if bit 2 is set in [A2H:110]; TX Fault from channel 2 if bit 2 is set in [B2H: 110]. Low indicates normal operation. In the low state, the output will be pulled to < 0.8V.
