

Overview

Axiom Connectivity Digital Return SFPs are designed for superior flexibility and adaptability. By integrating numerous technical innovations, this Digital Return SFP Series ensures prolonged support for evolving network architectures.

1. Features

- Up to 2.7Gb/s Optical Transmitters
- High-density SFP Transmitters
- Embedded Thermo-electric Cooling System
- 100GHz ITU Grid, C-Band TOSA (DFB-LD)
- LC/UPC Receptacle (9/125um, SMF)
- Compliant with SFP+ (Small Form Factor Pluggable Plus) MSA
- Digital Diagnostic Monitoring compliant
- Supports Serial ID functionality
- Class 1 Laser Safety products
- Single +3.3 V power supply with Hot-pluggable Interface
- ROHS compliant

2. Applications

- CPRI/OBSAI application : 1.2288, 2.4576Gb/s
- SONET/SDH application : 2.488Gb/s
- Fibre Channel application : 1.0625, 2.125Gb/s
- Digital repeater and Base station

3. Regulatory Compliance

Items	Standard	Performance
Electrostatic Discharge (ESD)	IEC 61000-4-2	Class 1
Electromagnetic Interference (EMI)	FCC Part 15 Class B	Compliant with standards(FCC)
Electromagnetic Compatibility (EMC)	Directive 89/336/EEC	Compliant with standards(CE)
Laser Eye Safety	FDA 21 CFR 1040.10 and 1040.11 EN (IEC) 60825-1,2	Class 1 laser product.
RoHS	Directive 2011/65/EU	Compliant with RoHS

4. Absolute Maximum Ratings

Parameters	Symbol	Ratings	Units	Conditions
Storage Temperature	T _{stg}	-40 ~ + 85	°C	Ambient
Power Supply Voltage	V _{cc}	< +4.0	V	-
Ambient Humidity	H _{op}	5 ~ 95	%	w/o dew

5. Operating conditions

Parameters	Symbol	Values				Conditions
		Min.	Typ.	Max.	Units	
Power supply voltage	V _{CC}	+3.135	+3.30	+3.465	V	-
Power supply current	I _{CC}	-	-	450	mA	Cooled type
Power Supply Noise Rejection	PSNR	-	-	100	mV _{p-p}	from 100Hz to 1MHz
Operating Temperature	T _C	-40	-	+92		Case, with Airflow

6. Optical Characteristics

Parameters	Symbol	Values				Conditions	
		Min.	Typ.	Max.	Units		
Transmitter							
Optical Transmit Power	P _f	+4.0	-	+8.0	dBm	-	
Transmitter Disable(O ff) Power	P _{off}	-	-	-30	dBm	@Tx_Disable is High	
Channel Spacing		100			GHz	Corresponds to approximately 0.8 nm	
Peak Wavelength	End of Life	λ _P	λ _C -100	λ _C	λ _C +100	pm	λ _C = 100GHz ITU Grid
	BOL Offset		λ _C -25	λ _C	λ _C +25		
Spectral Width	Δλ	-	-	0.3	nm	@ -20 dB	
Side Mode Suppression Ratio	SMSR	30	-	-	dB	-	
Optical Rise/Fall Time	T _f /T _r	-	-	160	ps	Unfiltered, 80% -20%	
RIN _{12OMA}	RIN	-	-	-120	dB/Hz	-	
Dispersion Penalty	DP	-	-	2.0	dB	2400ps/nm, BER1x10 ⁻¹²	
Transmitter Jitter (peak to peak)	T _{jpp}	-	-	75	mUI	-	
Extinction Ratio	ER	8.2	-	-	dB	@ 2.488 Gb/s, PRBS 2 ²³ -1	
Eye pattern Mask		OC -48 eye mask margin					

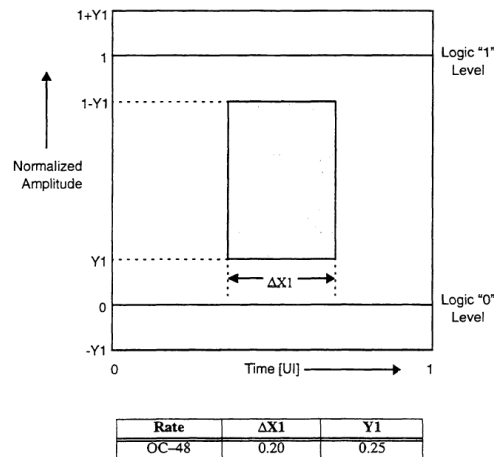

Figure 1. Mask of eye diagram for optical output (filtered)

7. Electrical Characteristics

Parameters	Symbol	Values				Conditions	
		Min.	Typ.	Max.	Units		
Transmitter							
Data Rate	DR_T	0.155	-	3.072	Gb/s	-	
Differential Input Voltage	V_{INpp}	150	-	1000	mV	-	
Differential Input Impedance	Z_{IN}	90	100	110	ohm	-	
Tx_Disable	Input_Low	V_{IL}	0	-	0.8	V	LVTTL, Normal at Low, High is Shutdown(P_{off})
	Input_High	V_{IH}	2.0	-	V_{CC}	V	
	Assert Time	t_{OFF}	-	-	10	us	High
	Negate Time	t_{ON}	-	-	1	ms	Low
Tx Disable to reset	t_{reset}	10	-	-	us	High	
Time to Initialize_Cooled, Including reset of Tx_Fault	t_{init_cooled}	-	-	90	sec	Cooled version, for wavelength stabilization at worst case(Low & High temperature)	
Tx_Fault	Output_Low	V_{FOL}	0	-	0.8	V	LVTTL, Low is Normal
	Output_High	V_{FOH}	2.0	-	$V_{CC}+0.3$	V	

8. Recommended Circuit Schematic

- Tx_Disable : Transmitter Disable, logic high, 4.7k to 10kohm pull up to Vcc on SFP
- Tx_Fault : Transmitter Fault, logic high, 4.7k to 10kohm pull up to Vcc on Host
- Rx_LOS : Receiver Loss of Signal, logic high, 4.7k to 10kohm pull up to Vcc on Host

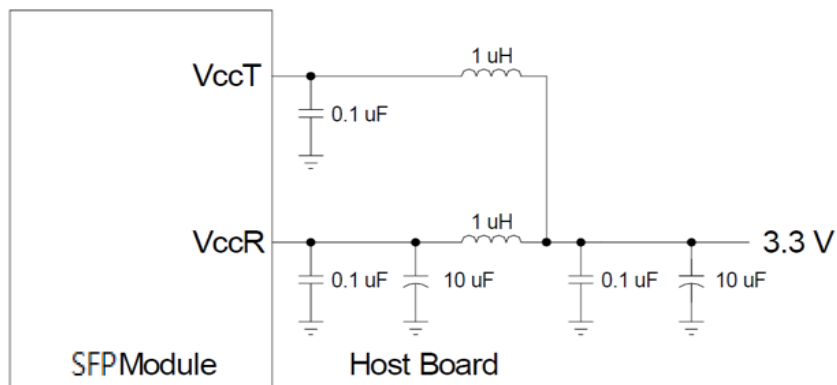
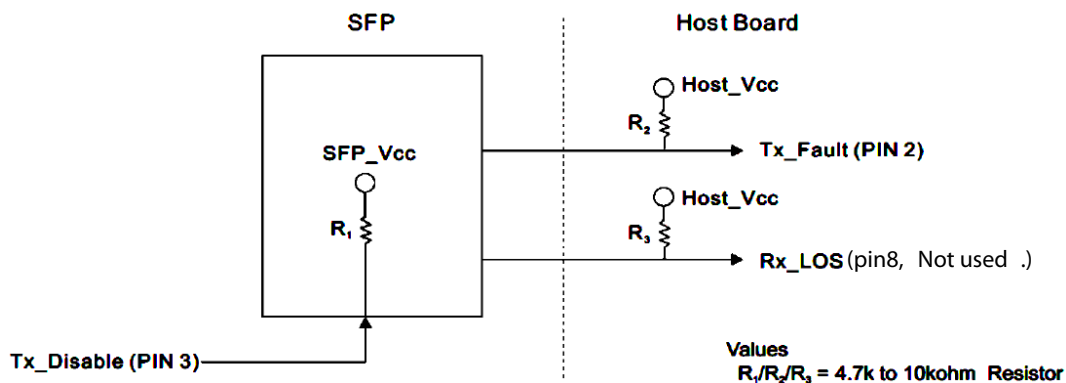

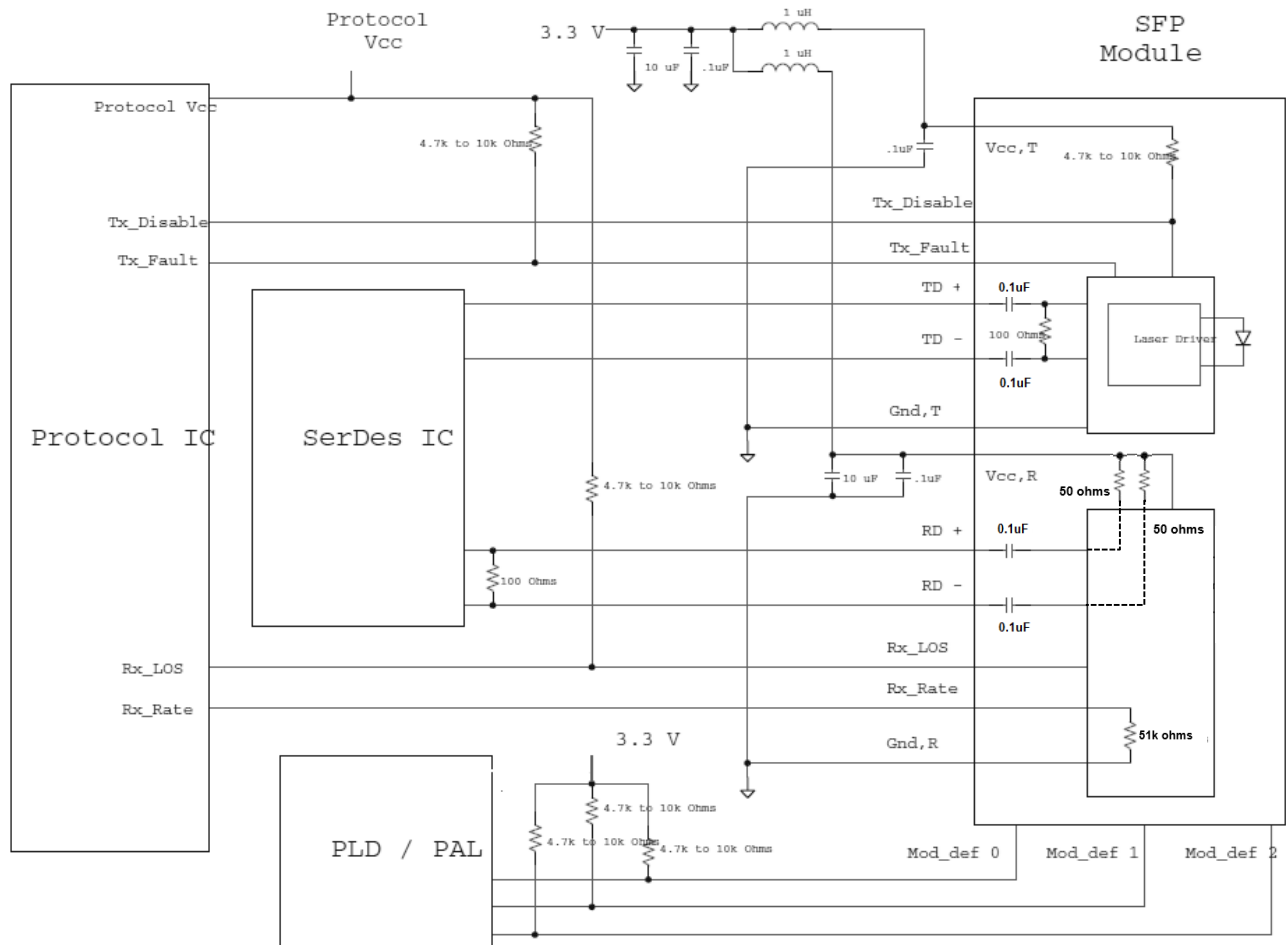

Figure 4. Example SFP Host Board Schematic

9. Pin Information

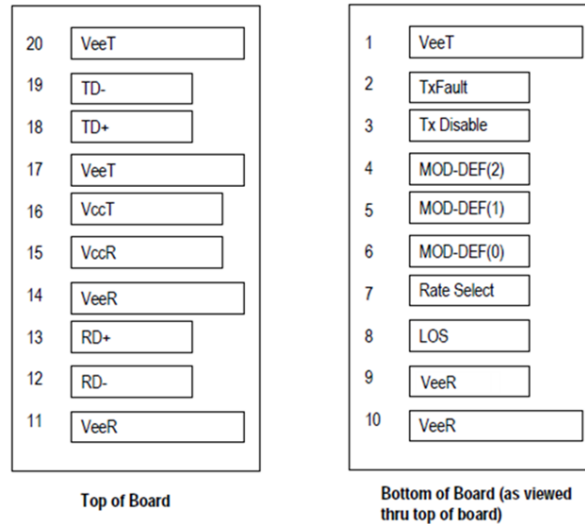

Figure 5.20 -pin Connector

Pin No.	Symbol	Descriptions	Sequence
Pin 1	TGND (VeeT)	Ground	1
Pin 2	Tx_Fault	Status Out	3
Pin 3	Tx_Disable	Control In	3
Pin 4	MOD_DEF(2)	Input/Output(SDA, I ² C data)	3
Pin 5	MOD_DEF(1)	Input/Output(SCL, I ² C clock)	3
Pin 6	MOD_DEF(0)	Indicates that the module is present , Grounded internally	3
Pin 7	Rate Select	Rate Select In 0, Not used(Internally pull -down, 51kohm)	3
Pin 8	RX_LOS	Status Out	3
Pin 9	RGND (VeeR)	Ground	3
Pin10	RGND (VeeR)	Ground	1
Pin 11	RGND (VeeR)	Ground	1
Pin 12	Rx_Data bar	Data Out Negative	3
Pin 13	Rx_Data	Data Out Positive	3
Pin 14	RGND (VeeR)	Ground	1
Pin 15	Rx_Vcc (VccR)	Power	2
Pin 16	Tx_Vcc (VccT)	Power	2
Pin 17	TGND (VeeT)	Ground	1
Pin 18	Tx_Data	Data In Positive	3
Pin 19	Tx_Data bar	Data In Negative	3
Pin 20	TGND (VeeT)	Ground	1

10. 2-Wire Serial-Port Operation

The 2-wire serial-port interface supports a bi-directional data transmission protocol with device addressing. Connections to the bus are made through MOD_DEF2 and MOD_DEF1. Timing diagrams for the 2-wire serial port can be found in Figure 6. Within the bus specifications, a standard mode (100kHz clock rate) and a fast mode (400kHz clock rate) are defined.

- The following bus protocol has been defined:

Data transfer may be initiated only when the bus is not busy. During data transfer, the data line must remain stable whenever the clock line is high. Changes in the data line while the clock line is high will be interpreted as control signals.

- **Bus not busy:** Both data and clock lines remain high.
- **Start data transfer:** A change in the state of the data line from high to low while the clock is high defines a START condition.
- **Stop data transfer:** A change in the state of the data line from low to high while the clock line is high defines the STOP condition.
- **Data valid:** The state of the data line represents valid data when, after a START condition, the data line is stable for the duration of the high period of the clock signal. The data on the line can be changed during the low period of the clock signal. There is one clock pulse per bit of data. Figure 6 detail how data transfer is accomplished on the 2-wire bus.
- **Clock and Data Transitions:** The MOD_DEF2 pin is normally pulled high with an external resistor or device. Data on the MOD_DEF2 pin may only change during MOD_DEF1 -low time periods. Data changes during MOD_DEF1 -high periods will indicate a START or STOP condition depending on the conditions discussed below.
- **START Condition:** A high-to-low transition of MOD_DEF2 with MOD_DEF1 high is a START condition that must precede any other command. See the timing diagrams in Figure 6 for further details.
- **STOP Condition:** A low-to-high transition of MOD_DEF2 with MOD_DEF1 high is a STOP condition. After a read or write sequence, the stop command places the condition into a low-power mode.
- **Acknowledge:** All address and data bytes are transmitted through a serial protocol. The DDM controller pulls the MOD_DEF2 line low during the ninth clock pulse to acknowledge that it has received each word.

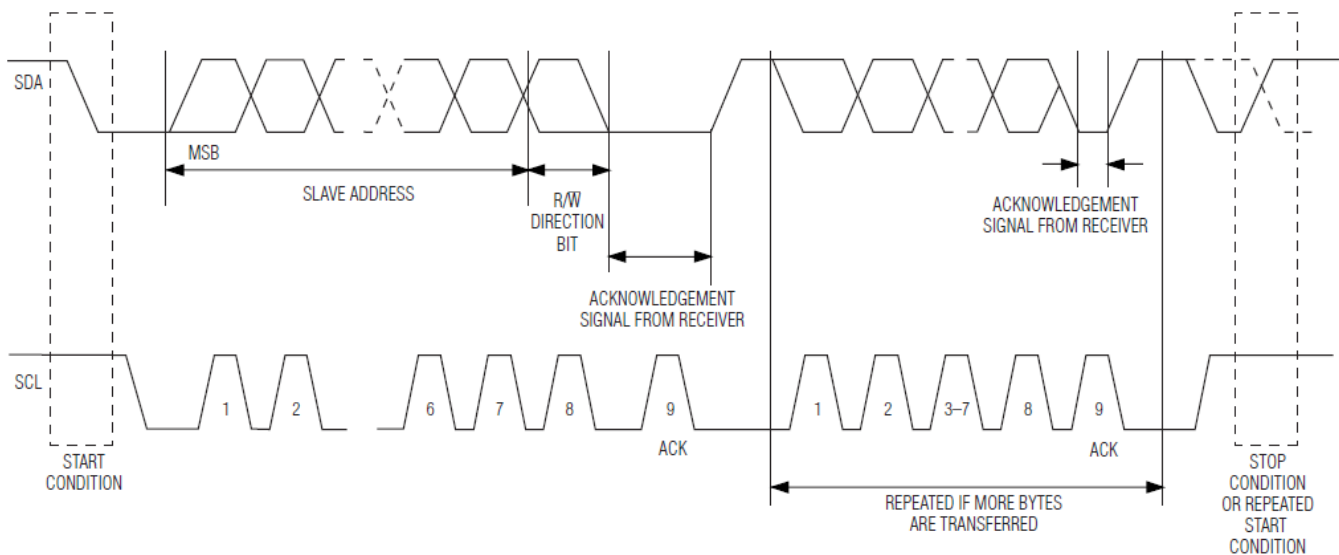

Figure 6. 2-Wire Data Transfer Protocol

11. Package Description & Outline Diagram

* Unit: [mm]

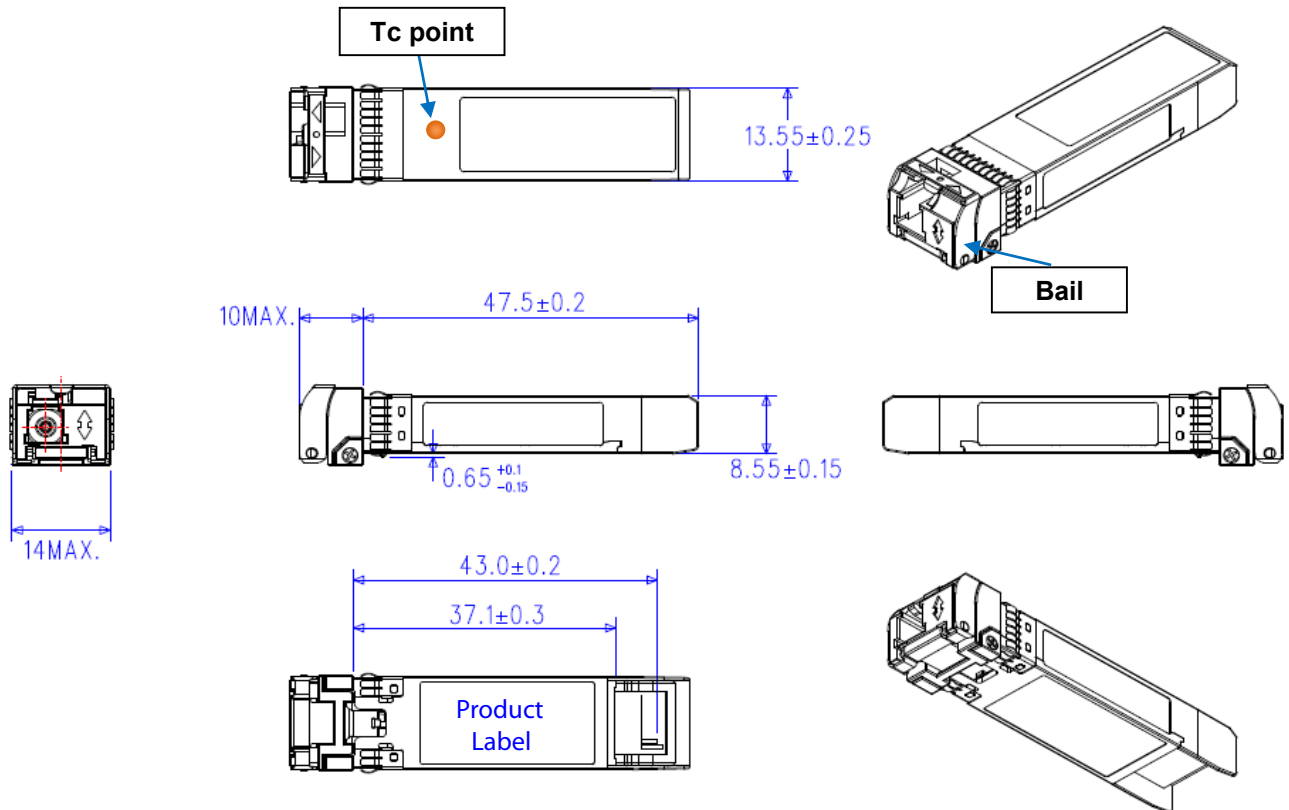

Figure 7. Package outline diagram and example

*** Part number information**

ITU-T CH No.	Part No	Frequency [THz]	Wavelength [nm]	ITU-T CH No.	Part No	Frequency [THz]	Wavelength [nm]
1	AC-B-DR2XD12-U01-yy	190.1	1557.03	32	AC-B-DR2XD12-U32-yy	193.2	1551.72
2	AC-B-DR2XD12-U02-yy	190.2	1576.20	33	AC-B-DR2XD12-U33-yy	193.3	1550.92
3	AC-B-DR2XD12-U03-yy	190.3	1575.37	34	AC-B-DR2XD12-U34-yy	193.4	1550.12
4	AC-B-DR2XD12-U04-yy	190.4	1574.54	35	AC-B-DR2XD12-U35-yy	193.5	1549.32
5	AC-B-DR2XD12-U05-yy	190.5	1573.71	36	AC-B-DR2XD12-U36-yy	193.6	1548.51
6	AC-B-DR2XD12-U06-yy	190.6	1572.89	37	AC-B-DR2XD12-U37-yy	193.7	1547.72
7	AC-B-DR2XD12-U07-yy	190.7	1572.06	38	AC-B-DR2XD12-U38-yy	193.8	1546.92
8	AC-B-DR2XD12-U08-yy	190.8	1571.24	39	AC-B-DR2XD12-U39-yy	193.9	1546.12
9	AC-B-DR2XD12-U09-yy	190.9	1570.42	40	AC-B-DR2XD12-U40-yy	194.0	1545.32
10	AC-B-DR2XD12-U10-yy	191.0	1569.59	41	AC-B-DR2XD12-U41-yy	194.1	1544.53
11	AC-B-DR2XD12-U11-yy	191.1	1568.77	42	AC-B-DR2XD12-U42-yy	194.2	1543.73
12	AC-B-DR2XD12-U12-yy	191.2	1567.95	43	AC-B-DR2XD12-U43-yy	194.3	1542.94
13	AC-B-DR2XD12-U13-yy	191.3	1567.13	44	AC-B-DR2XD12-U44-yy	194.4	1542.14
14	AC-B-DR2XD12-U14-yy	191.4	1566.31	45	AC-B-DR2XD12-U45-yy	194.5	1541.35
15	AC-B-DR2XD12-U15-yy	191.5	1565.50	46	AC-B-DR2XD12-U46-yy	194.6	1540.56
16	AC-B-DR2XD12-U16-yy	191.6	1564.68	47	AC-B-DR2XD12-U47-yy	194.7	1539.77
17	AC-B-DR2XD12-U17-yy	191.7	1563.86	48	AC-B-DR2XD12-U48-yy	194.8	1538.98
18	AC-B-DR2XD12-U18-yy	191.8	1563.05	49	AC-B-DR2XD12-U49-yy	194.9	1538.19
19	AC-B-DR2XD12-U19-yy	191.9	1562.23	50	AC-B-DR2XD12-U50-yy	195.0	1537.40
20	AC-B-DR2XD12-U20-yy	192.0	1561.42	51	AC-B-DR2XD12-U51-yy	195.1	1536.61
21	AC-B-DR2XD12-U21-yy	192.1	1560.61	52	AC-B-DR2XD12-U52-yy	195.2	1535.82
22	AC-B-DR2XD12-U22-yy	192.2	1559.79	53	AC-B-DR2XD12-U53-yy	195.3	1535.04
23	AC-B-DR2XD12-U23-yy	192.3	1558.98	54	AC-B-DR2XD12-U54-yy	195.4	1534.25
24	AC-B-DR2XD12-U24-yy	192.4	1558.17	55	AC-B-DR2XD12-U55-yy	195.5	1533.47
25	AC-B-DR2XD12-U25-yy	192.5	1557.36	56	AC-B-DR2XD12-U56-yy	195.6	1532.68
26	AC-B-DR2XD12-U26-yy	192.6	1556.55	57	AC-B-DR2XD12-U57-yy	195.7	1531.90
27	AC-B-DR2XD12-U27-yy	192.7	1555.75	58	AC-B-DR2XD12-U58-yy	195.8	1531.12
28	AC-B-DR2XD12-U28-yy	192.8	1554.94	59	AC-B-DR2XD12-U59-yy	195.9	1530.33
29	AC-B-DR2XD12-U29-yy	192.9	1554.13	60	AC-B-DR2XD12-U60-yy	196.0	1529.55
30	AC-B-DR2XD12-U30-yy	193.0	1553.33	61	AC-B-DR2XD12-U61-yy	196.1	1528.77
31	AC-B-DR2XD12-U31-yy	193.1	1552.52				