

40Gb/s QSFP+ LR4 Lite 2km Optical Transceiver

Product Features

- Compliant with 40G Ethernet IEEE802.3ba and 40GBASE-LR4 Standard
- Uncooled 4x10Gb/s CWDM transmitter
- Supports Infiniband SDR, DDR and QDR
- Wide Operating Temperature (0°C~70°C)
- Maximum link length of 2km on Single Mode Fiber (SMF)

Applications

- Data Center Backbone
- Ethernet Switches
- High-speed Servers
- High-performance Computing Clusters
- SAN, Routers, Hubs, Load Balancer

This product is a transceiver module designed for up to 2km optical communication applications. The design is compliant to 40GBASE-LR4 of the IEEE P802.3ba standard. The module converts 4 inputs channels (ch) of 10Gb/s electrical data to 4 CWDM optical signals, and multiplexes them into a single channel for 40Gb/s optical transmission. Reversely, on the receiver side, the module optically de-multiplexes a 40Gb/s input into 4 CWDM channels signals, and converts them to 4 channel output electrical data.

The central wavelengths of the 4 CWDM channels are 1271, 1291, 1311 and 1331 nm as members of the CWDM wavelength grid defined in ITU-T G.694.2. It contains a duplex LC connector for the optical interface and a 38-pin connector for the electrical interface. To minimize the optical dispersion in the long-haul system, single-mode fiber (SMF) has to be applied in this module.

The product is designed with form factor, optical/electrical connection and digital diagnostic interface according to the QSFP+ Multi-Source Agreement (MSA). It has been designed to meet the harshest external operating conditions including temperature, humidity and EMI interference.

Ordering Information

Part Number	Description
AC-B-Q40L4L-xx	QSFP+ LR4 2km optical transceiver with full real-time digital diagnostic monitoring

Regulatory Compliance

Feature	Standard	Performance
Electromagnetic Interference (EMI)	FCC Part 15 Class B EN 55022:2010, Class B	Compatible with standards
Electromagnetic susceptibility (EMS)	EN 55024:2010	Compatible with standards
Laser Eye Safety	FDA 21CFR 1040.10 and 1040.11 EN60950, EN (IEC) 60825-1,2	Compatible with Class I laser product

Absolute Maximum Ratings

It has to be noted that the operation in excess of any individual absolute maximum ratings might cause permanent damage to this module.

Parameter	Symbol	Min	Max	Unit	Notes
Storage Temperature	TS	0	85	°C	
Relative Humidity (non-condensation)	RH	0	85	%	

Recommended Operating Conditions and Power Supply Requirements

Parameter	Symbol	Min	Typical	Max	Unit	Notes
Operating Case Temperature	TOP	0		70	°C	
Power Supply Voltage	VCC	3.15	3.3	3.45	V	
Data Rate, each Lane			10.3125		Gb/s	
Two Wire Serial (TWS) Interface Clock Rate				400	kHz	
Power Supply Noise				50	mVpp	
Supply Noise Rejection				100	mV	
Receiver Differential Data Output			100		Ohm	
Operating Distance	D			2	km	

Electrical Characteristics

The following electrical characteristics are defined over the Recommended Operating Environment unless otherwise specified.

Parameter	Test Point	Min	Typical	Max	Unit	Notes
Power Consumption				2.5	W	
Supply Current	I _{cc}			0.8	A	
Transceiver Power-on Initialization Time				2000	ms	1
Transmitter (each Lane)						
Single-ended Input Voltage Tolerance (Note 2)		-0.3		4.0	V	Referred to TP1 signal common
AC Common Mode Input Voltage Tolerance		15			mV	RMS
Differential Input Voltage Swing Threshold		50			mVpp	LOSA Threshold
Differential Input Voltage Swing	V _{in,pp}	190		700	mVpp	
Differential Input Impedance	Z _{in}	90	100	110	ohm	
Differential Input Return Loss		See IEEE 802.3ba 86A.4.11			dB	10MHz- 11.1GHz
J2 Jitter Tolerance	Jt2	0.17			UI	
J9 Jitter Tolerance	Jt9	0.29			UI	
Data Dependent Pulse Width Shrinkage (DDPWS) Tolerance		0.07			UI	

Eye Mask Coordinates {X1, X2, Y1, Y2}		0.11, 0.31 95, 350			UI mV	Hit Ratio = 5x10 ⁻⁵
Receiver (each Lane)						
Single-ended Output Voltage		-0.3		4.0	V	Referred to signal common
AC Common Mode Output Voltage				7.5	mV	RMS
Differential Output Voltage Swing	Vout,pp	300		850	mVpp	
Differential Output Impedance	Zout	90	100	110	ohm	
Termination Mismatch at 1MHz				5	%	
Differential Output Return Loss		See IEEE 802.3ba 86A.4.2.1			dB	10MHz- 11.1GHz
Common Mode Output Return Loss		See IEEE 802.3ba 86A.4.2.2			dB	10MHz- 11.1GHz
Output Transition Time		28			Ps	20% to 80%
J2 Jitter Output	Jo2			0.42	UI	
J9 Jitter Output	Jo9			0.65	UI	
Eye Mask Coordinates {X1, X2, Y1, Y2}		0.29, 0.5, 150, 425			UI mV	Hit Ratio = 5x10 ⁻⁵

Notes:

1. Power-on Initialization Time is the time from when the power supply voltages reach and remain above the minimum recommended operating supply voltages to the time when the module is fully functional.
2. The single ended input voltage tolerance is the allowable range of the instantaneous input signals.

Optical Characteristic

The following electrical characteristics are defined over the Recommended Operating Environment unless otherwise specified.

Parameter	Test Point	Min	Typical	Max	Unit	Notes
Transmitter Characteristics						
Signal rate, each lane (range)	GBb		10.3125		GBb	
Center Wavelength	L0	1264.5		1277.5	nm	
	L1	1284.5		1297.5	nm	
	L2	1304.5		1317.5	nm	
	L3	1324.5		1337.5	nm	
Side-mode suppression ratio	SMSR		30		dB	
Total average launch power				8.3	dBm	
Average launch power each lane	Pf	-7		2.3	dBm	
Optical Modulation Amplitude (OMA), each lane	TxOMA	-6		3.5	dBm	
Difference in launch power between any two lanes (OMA)				6.5	dB	
Transmitter and Dispersion Penalty	TDP			2.6	dB	
Launch power in OMA minus TDP, each lane	Tx_TDP	-4.8			dBm	
Average launch power of OFF transmitter, each lane				-30	dBm	

Extinction ratio	ER	3.5			dB	
Relative Intensity Noise				-128	dB/Hz	
Optical return loss tolerance				20	dB	
Transmitter reflectance				-12	dB	
Receiver Characteristics						
Signaling rate, each lane (range)	GBb		10.3125		GBb	
Center Wavelength	L0	1264.5		1277.5	nm	
	L1	1284.5		1297.5	nm	
	L2	1304.5		1317.5	nm	
	L3	1324.5		1337.5	nm	
Damage threshold		3.3			dBm	
Average power at receiver input, each lane		-13.7		2.3	dBm	
Receive power, each lane (OMA)				3.5	dBm	
Difference in receive power between any two lanes (OMA)				7.5	dBm	
Receiver reflectance				-26	dB	
Receiver sensitivity (OMA)	SOMA			-11.5	dBm	
LOS Assert	LOS _A	-28			dBm	
LOS De-Assert	LOS _D			-15	dBm	
LOS Hysteresis		0.5		6	dB	

Digital Diagnostic Functions

The following digital diagnostic characteristics are defined over the normal operating conditions unless otherwise specified.

Parameter	Symbol	Min	Max	Unit	Notes
Temperature monitor absolute error	DMI_Temp	-3	+3	°C	
Supply voltage monitor absolute error	DMI_VCC	-0.1	+0.1	V	
Channel RX power monitor absolute error	DMI_RX_Ch	-2	+2	dB	
Channel Bias current monitor	DMI_Ibias_Ch	-10%	+10%	mA	
Channel TX power monitor absolute error	DMI_TX_Ch	-2	+2	dB	

Block Diagram of Transceiver

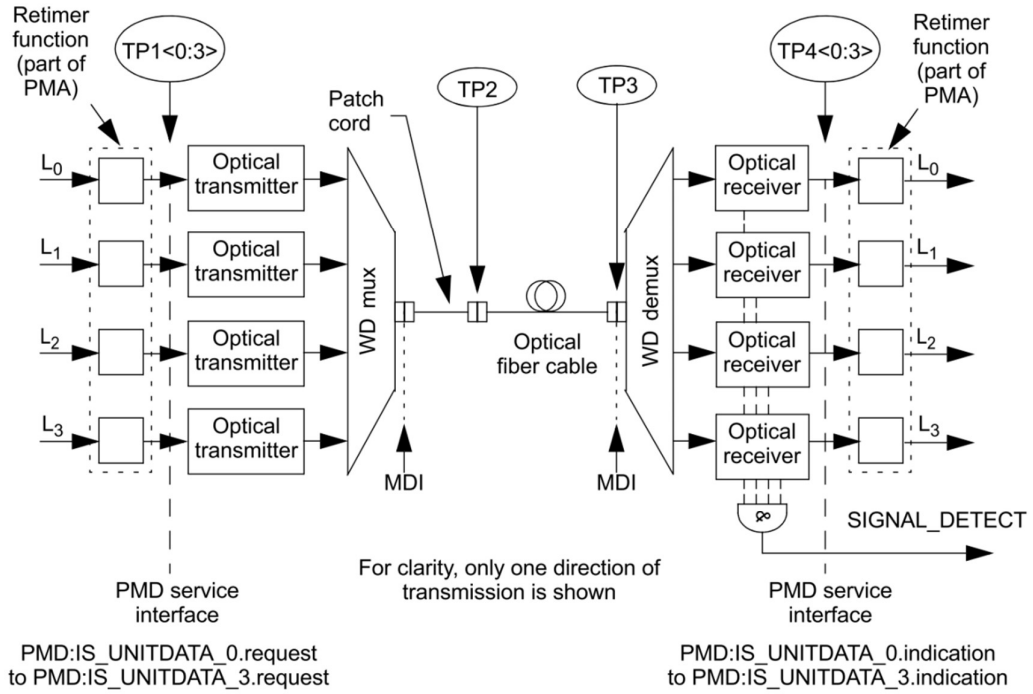

WD = Wavelength division

NOTE—Specification of the retimer function is beyond the scope of this standard.

Mechanical Dimensions

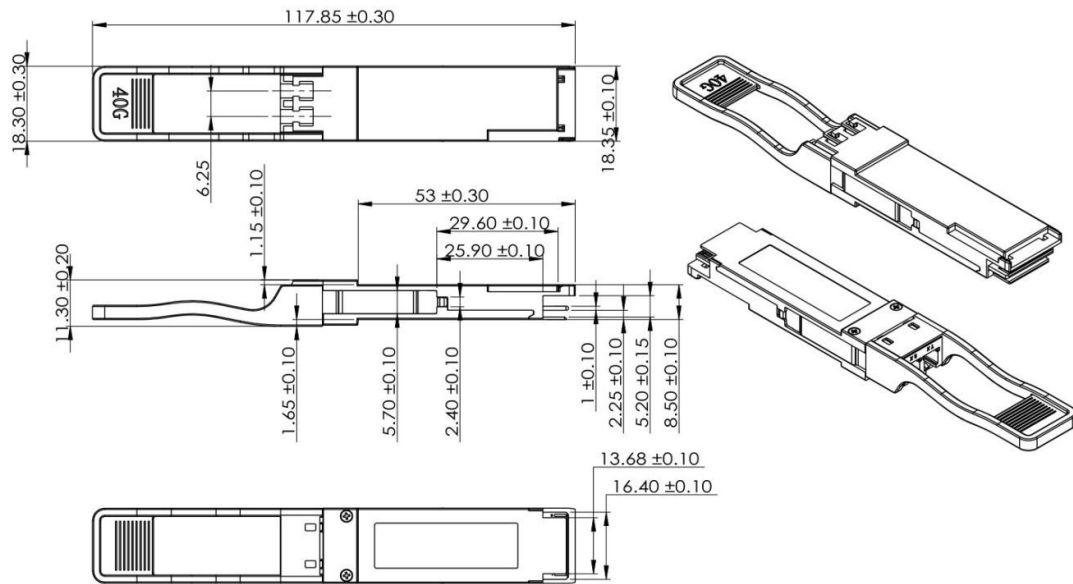

ESD

This transceiver is specified as ESD threshold 1kV for SFI pins and 2kV for all other electrical input pins, tested per MIL-STD-883, Method 3015.4 /JESD22-A114-A (HBM). However, normal ESD precautions are still required during the handling of this module. This transceiver is shipped in ESD protective packaging. It should be removed from the packaging and handled only in an ESD protected environment.

Laser Safety

This is a Class 1 Laser Product according to IEC 60825-1:2007. This product complies with 21 CFR 1040.10 and 1040.11 except for deviations pursuant to Laser Notice No. 50, dated (June 24, 2007).

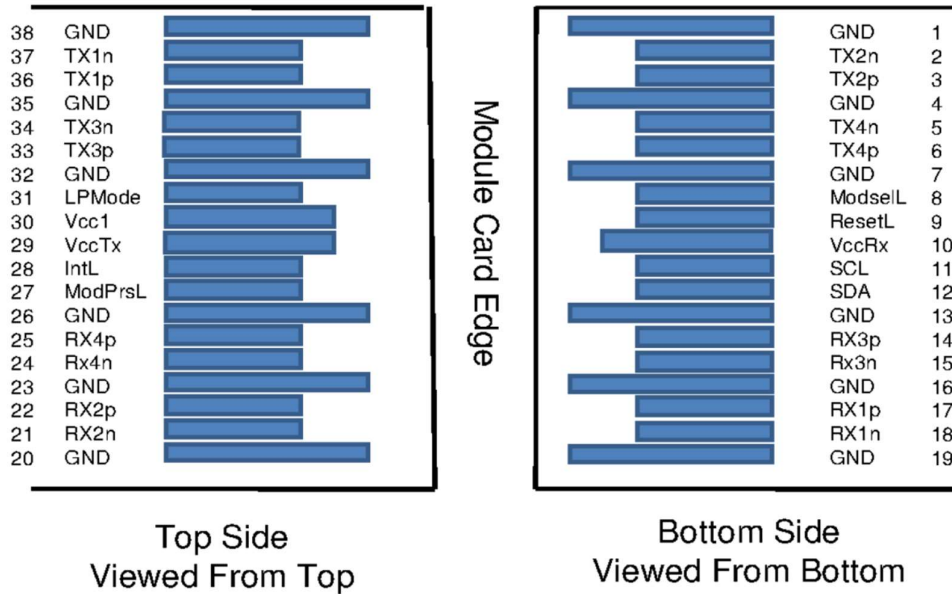
Pin Assignment and Description

Pin Assignment

PIN #	Logic	Symbol	Description	Notes
1		GND	Ground	
2	CML-I	Tx2n	Transmitter Inverted Data Input	
3	CML-I	Tx2p	Transmitter Non-Inverted Data output	
4		GND	Ground	
5	CML-I	Tx4n	Transmitter Inverted Data Input	
6	CML-I	Tx4p	Transmitter Non-Inverted Data output	
7		GND	Ground	
8	LVTLL-I	ModSelL	Module Select	
9	LVTLL-I	ResetL	Module Reset	
10		VccRx	+3.3V Power Supply Receiver	
11	LVC MOS-I/O	SCL	2-Wire Serial Interface Clock	
12	LVC MOS-I/O	SDA	2-Wire Serial Interface Data	
13		GND	Ground	
14	CML-O	Rx3p	Receiver Non-Inverted Data Output	
15	CML-O	Rx3n	Receiver Inverted Data Output	
16		GND	Ground	
17	CML-O	Rx1p	Receiver Non-Inverted Data Output	
18	CML-O	Rx1n	Receiver Inverted Data Output	
19		GND	Ground	

20		GND	Ground
21	CML-O	Rx2n	Receiver Inverted Data Output
22	CML-O	Rx2p	Receiver Non-Inverted Data Output
23		GND	Ground
24	CML-O	Rx4n	Receiver Inverted Data Output
25	CML-O	Rx4p	Receiver Non-Inverted Data Output
26		GND	Ground
27	LVTTL-O	ModPrsL	Module Present
28	LVTTL-O	IntL	Interrupt
29		VccTx	+3.3 V Power Supply transmitter
30		Vcc1	+3.3 V Power Supply
31	LVTTL-I	LPMMode	Low Power Mode
32		GND	Ground
33	CML-I	Tx3p	Transmitter Non-Inverted Data Input
34	CML-I	Tx3n	Transmitter Inverted Data Output
35		GND	Ground
36	CML-I	Tx1p	Transmitter Non-Inverted Data Input
37	CML-I	Tx1n	Transmitter Inverted Data Output
38		GND	Ground