

25Gbps SFP28 BIDI TX1330/RX1270nm 10km Optical Transceiver

Product Features

- LC connector Support up to 28Gb/s bit rates
- Compliant with SFP28 MSA
- Electrical interface compliant to SFF-8431
- Hot-pluggable SFP28 footprint
- Built-in digital diagnostic functions
- Up to 10 km on 9/125um SMF G.652
- Single power supply 3.3V
- RoHS6/6 compliant
- Class 1 laser product complies with EN 60825-1
- Operating temperature range: 0°C to 70°C
- Power consumption <1.2W

The AC-B-S28BI10-32-xx is compliant with SFF-8431. It offers previously unavailable system cost, upgrade, and reliability benefits by virtue of being hot-pluggable.

Ordering Information

Part Number	Description
AC-B-S28BI10-32-xx	25Gb/s BIDI TX1330/RX1270nm 10km SFP28 Transceiver, LC, With DDM

Regulatory Compliance

Feature	Standard	Performance
Electromagnetic Interference (EMI)	FCC Part 15 Class B EN 55022:2010, Class B	Compatible with standards
Electromagnetic susceptibility (EMS)	EN 55024:2010	Compatible with standards
Laser Eye Safety	FDA 21CFR 1040.10 and 1040.11 EN60950, EN (IEC) 60825-1,2	Compatible with Class I laser product

Applications

- 25GBASE-LR

Absolute Maximum Ratings

The operation in excess of any absolute maximum ratings might cause permanent damage to this module.

Parameter	Symbol	Min	Max	Unit	Notes
Storage Temperature	TS	-40	85	°C	
Operating Case Temperature	TOP	0	70	°C	
Power Supply Voltage	V _{CC}	-0.5	3.6	V	
Relative Humidity (non-condensation)	RH	5	95	%	

Recommended Operating Conditions and Power Supply Requirements

Parameter	Symbol	Min	Typical	Max	Unit	Notes
Operating Case Temperature	TOP	0		70	°C	
Power Supply Voltage	V _{CC}	3.135	3.3	3.465	V	
Power Consumption				1.5	W	
Power Supply Current @ 3.3V	I _{CC}			350	mA	

Optical Characteristics

All parameters are specified under the recommended operating conditions unless otherwise specified..

Parameter	Symbol	Min	Typical	Max	Unit	Notes
Transmitter						
Support data rate	-	-	-	28	Gb/s	-
Peak Wavelength	λ _p	1320	1330	1340	nm	4
Spectral Width (-20dB)	Δλ	-	-	1	nm	-
Side Mode Suppression Ratio	SMSR	30			dB	
Average Optical Output Power	P _o	-5	-	2	dBm	
Extinction Ratio	Er	3.5	-	-	dB	

Transmitter and dispersion penalty	TDP			3	dB	
Output Power with Transmitter Disabled	Poff			-30	dBm	
Transmitter Enable Voltage	VEN	-0.3	-	0.8	V	
Transmitter Disable Voltage	VD	2.0	-	Vcc+0.3	V	
Differential Data Input Swing	VINpp	180	-	700	mV	
Optical return loss tolerance				-12	dB	
Output Eye Diagram	Compliant with IEEE 802.3					1
Receiver						
Support data rate	-	-	-	28	Gb/s	-
Operate Wavelength	-	1260	1270	1280	nm	-
Receiver sensitivity @25Gb/s	Sen	-	-	-12	dBm	2
Saturation	Psat	2	-	-	dBm	2
LOS Asserted	T_loss_on	-30	-	-	dBm	High level: Alarm
LOS De-Asserted	T_loss_off	-	-	-13	dBm	
LOS Hysteresis	T_loss_Hs	0.5	-	5.0	dB	
Differential Data Output Swing	VOUTPP	450	-	1050	mV	-
LOS Low Voltage	VLout	-	-	0.4	V	-
LOS High Voltage	VHout	2.0	-	-	V	-

Notes:

1. At least 1000 waveforms acquired, with minimum 5% margin against 802.3 mask
2. Test at 25.78125Gb/s, PRBS 2³¹-1, BER of 5E-5, NRZ and including back to back

Digital Diagnostic Functions

Digital diagnostics monitoring function is available on Axiom products. A 2-wire serial interface provides user to contact with module. It is compliant to SFF-8472 Rev10.2 with internal calibration mode. For external calibration mode please contact our sales staff.

Parameter	Symbol	Min	Max	Unit	Notes
Temperature monitor absolute error	DMI_Temp	-3	+3	°C	
Supply voltage monitor absolute error	DMI_VCC	-3%	+3%	V	
TX power monitor absolute error	DMI_RX	-3	+3	dB	
RX power monitor absolute error	DMI_RX	-3	+3	dB	
Bias current monitor	DMI_Ibias	-10%	+10%	mA	

Recommended Circuit

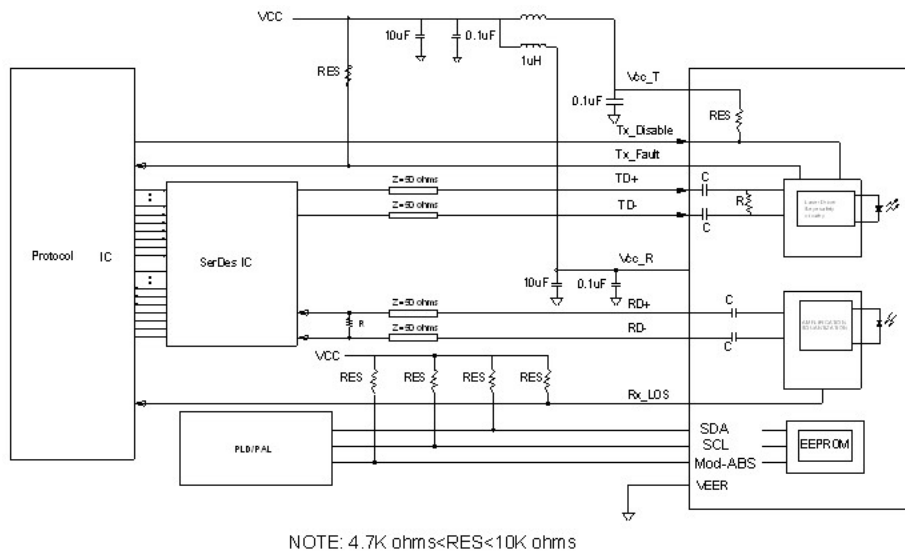

Mechanical Dimensions

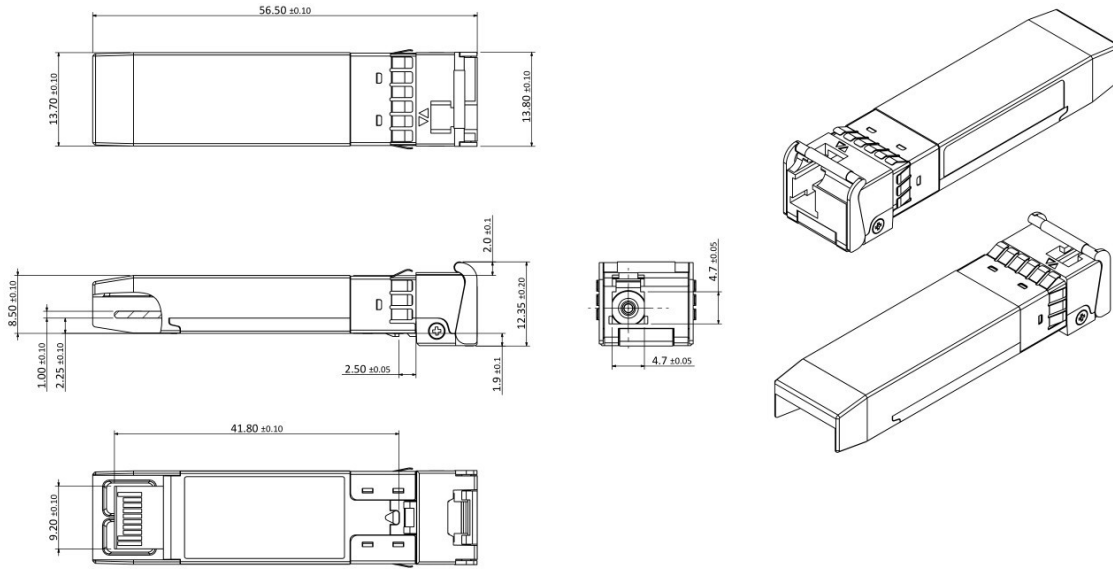

Pin Assignment and Description

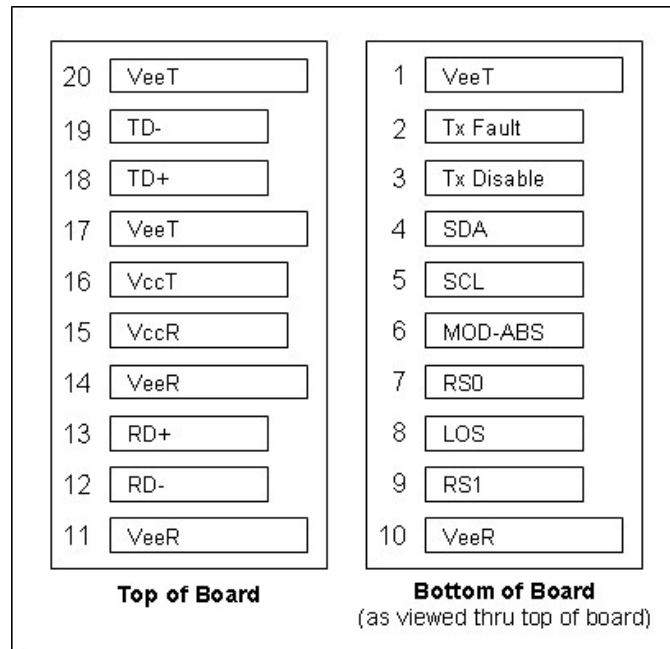

Pin Assignment

PIN #	Symbol	Description	Notes
1	VeeT	Transmitter Ground	
2	TX Fault	Transmitter Fault Indication	Note 1
3	TX Disable	Transmitter Disable	Note 2, Module disables on high or open
4	SDA	2-wire Serial Interface Data Line(Same as MOD-DEF2 in INF-8074i)	
5	SCL	2 Wire Serial Interface Data Line (Same as MOD-DEF1 as defined in the INF-8074i)	
6	MOD-ABS	Module Absent,Connected to VeeT or VeeR in the module.	Note 3
7	RS0	SFP+ RX Rate Select, optional	Rate Select0,Not used.Note 9
8	LOS	Loss of Signal	Note 4
9	RS1	SFP+ TX Rate Select, optional	Rate Select 1, Not used.Note 9
10	VeeR	Receiver Ground	Note 5
11	VeeR	Receiver Ground	Note 5
12	RD-	Inv. Received Data Out	Note 6
13	RD+	Received Data Out	Note 6
14	VeeR	Receiver Ground	Note 5
15	VccR	Receiver Power	Note 7, 3.3V □ 5%
16	VccT	Transmitter Power	Note 7, 3.3V □ 5%
17	VeeT	Transmitter Ground	Note 5
18	TD+	Transmit Data In	Note 8

19	TD-	Inv. Transmit Data In	Note 8
20	VeeT	Transmitter Ground	Note 5

Notes:

Plug Seq.: Pin engagement sequence during hot plugging.

1. TX Fault is an open collector/drain output, which should be pulled up with a 4.7K – 10KΩ resistor on the host board. Pull up voltage between 2.0V and VccT +0.3V. When high, output indicates a laser fault of some kind. Low indicates normal operation. In the low state, the output will be pulled to < 0.4V.
2. TX disable is an input that is used to shut down the transmitter optical output. It is pulled up within the module with a 4.7 – 10 KΩ resistor. Its states are:

 Low (-0.3 – 0.8V):Transmitter on (>0.8, < 2.0V):Undefined

 High (2.0 – VccT+0.3V):Transmitter Disabled Open:Transmitter Disabled
3. Mod-ABS shall be pulled up with a 4.7K – 10KΩ resistor on the host board. The pull -up voltage shall VccT or VccR.
4. LOS (Loss of Signal) is an open collector/ drain output, which should be pulled up with a 4.7K – 10KΩ resistor. Pull up voltage between 2.0V and VccR+0.3V. When high, this output indicates the received optical power is below the worst-case receiver sensitivity (as defined by the standard in use). Low indicates normal operation. In the low state, the output will be pulled to < 0.4V.
5. VeeR and VeeT may be internally connected within the SFP module.
6. RD-/+ : These are the differential receiver outputs. They are AC coupled 100Ω differential lines which should be terminated with 100Ω (differential) at the user SERDES. The AC coupling is done inside the module and is thus not required on the host board.
7. VccR and VccT are the receiver and transmitter power supplies. They are defined as 3.3V 5% at the SFP connector pin. Maximum supply current is 300mA. Recommended host board power supply filtering is shown below. Inductors with DC resistance of less than 1Ω should be used in order to maintain the required voltage at the SFP input pin with 3.3V supply voltage.

 When the recommended supply filtering network is used, hot plugging of the SFP transceiver module will result in an inrush current of no more than 30 mA greater than the steady state value. VccR and VccT may be internally connected within the SFP transceiver module.
8. TD-/+ : These are the differential transmitter inputs. They are AC -coupled, differential lines with 100Ω differential termination inside the module. The AC coupling is done inside the module and is thus not required on the host board.
9. Internally pulled down per SFF-8431 Rev 4.1.