

1.25Gb/s SFP(Small Form Pluggable) Tx1310nm/Rx1490nm Bi-directional Transceiver

Overview

Axiom's AC-B-SFPBX40-34-xx SFP-BIDI optical transceivers, according to Small Form Factor Pluggable Multi-Sourcing Agreement (MSA) SFF-8074i and SFF-8472, are designed for single fiber bidirectional data communication up to 40km. The product complies with IEEE Std 802.3- 2005 1000BASE-BX-U.

Product Features

- Up to 1.25Gb/s bi-directional data links
- Hot-pluggable SFP footprint
- Built-in digital diagnostic functions
- Uncooled 1310nm DFB Laser
- Simplex LC connector
- Up to 40km on 9/125 μ m SMF
- Single power supply 3.3V
- RoHS6 Compliant
- Operating case temperature range: 0° C to 70° C

Applications

- 1000BASE-BX-U
- WDM Gigabit Ethernet Links
- Fast Ethernet
- Other Optical Links

Ordering Information

Part Number	Description	Color on Clasp
AC-B-SFPBX40-34-xx	SFP-BIDI, Simplex LC connector, Tx1310nm/Rx1490nm, 40km	Blue

General Specifications

Parameter	Symbol	Min	Typ	Max	Unit	Remarks
Data Rate	DR			1.25	Gb/s	1
Bit Error Rate	BER			10^{-12}		
Operating Temperature	T _C	0		70	°C	2
Storage Temperature	T _{STO}	-40		85	°C	3
Supply Current	I _{CC}			300	mA	4
Input Voltage	V _{CC}	3.14	3.3	3.46	V	
Maximum Voltage	V _{MAX}	-0.5		4	V	4

Notes:

- 1.IEEE 802.3
- 2.Case temperature
- 3.Ambient temperature
- 4.For electrical power interface

Optical – Characteristics – Transmitter

$V_{CC}=3.14V$ to $3.46V$, $T_C=0^{\circ}C$ to $70^{\circ}C$

Parameter	Symbol	Min	Typ	Max	Unit	Remarks
Output Optical Power	P_{TX}	-3		2	dBm	1
Optical Center Wavelength	λ_C	1260	1310	1360	nm	
Extinction Ratio	ER	9			dB	
Spectral Width(-20dB)	$\Delta \lambda$			1	nm	
Side Mode Suppression Ratio	SMSR	30			dB	
Optical Rise/Fall Time(20%-80%)	t_r/t_f			260	ps	
Launch Power of OFF Transmitter	P_{OUT_OFF}			-45	dBm	
Eye Diagram	Compliant with IEEE 802.3z					

Notes:

1.Average Launch Power

Optical – Characteristics – Receiver

$V_{CC}=3.14V$ to $3.46V$, $T_C=0^{\circ}C$ to $70^{\circ}C$

Parameter	Symbol	Min	Typ	Max	Unit	Remarks
Optical Center Wavelength	λ_C	1470	1490	1510	nm	
Receiver Sensitivity	R_{X_SEN}			-23	dBm	1
Receiver Overload	P_{OL}	0			dBm	
Optical Return Loss	ORL	12			dB	
LOS Assert	LOS_A	-35			dBm	
LOS De-Assert	LOS_D			-24	dBm	
LOS Hysteresis	LOS_H	0.5			dB	

Notes:

1.Measured with PRBS 2⁷-1 test pattern, BER< 10⁻¹²

Electrical – Characteristics – Transmitter

V_{CC}=3.14V to 3.46V, T_C=0° C to 70° C

Parameter	Symbol	Min	Typ	Max	Unit	Remarks
Input differential impedance	R _{IN}		100		Ω	
Single ended data input swing	V _{IN_PP}	250		1200	mV	
Transmit disable voltage	V _D	V _{CC} -1.3		V _{CC}	V	
Transmit enable voltage	V _{EN}	V _{EE}		V _{EE} + 0.8	V	
Transmit disable assert time				10	μs	

Electrical – Characteristics – Receiver

V_{CC}=3.14V to 3.46V, T_C=0° C to 70° C

Parameter	Symbol	Min	Typ	Max	Unit	Remarks
Single ended data output swing	V _{OUT_PP}	300	400	800	mV	
Data output rise/fall time (20%-80%)	t _r /t _f			300	ps	
LOS Assert	V _{LOS_A}	V _{CC} -0.5		V _{CC_HOST}	V	
LOS De-Assert	V _{LOS_D}	V _{EE}		V _{EE} + 0.5	V	

Digital Diagnostic Functions

AC-B-SFPBX40-34-xx supports the 2-wire serial communication protocol as defined in SFP MSA. Digital diagnostic information is accessible over the 2-wire interface at the address 0xA2. Digital diagnostics for AC-B-SFPBX40-34-xx are internally calibrated by default. The internal micro control unit accesses the device operating parameters in real time, such as transceiver temperature, laser bias current, transmitted optical power, received optical power and transceiver supply voltage. The module implements the alarm function of the SFP MSA, alerts the user when a particular operating parameter exceeds the factory-set normal range.

Parameter	Symbol	Accuracy	Units	Report Range		Unit	Remarks
Internal Calibration							
Temperature	Temp	±3	°C	-15	80	°C	
Voltage	V _{CC}	±0.1	V	3.0	3.6	V	
Bias Current	I _{bias}	±10	%	0	80	mA	
Tx Power	P _{TX}	±3	dB	-6	1	dBm	
Rx Power	P _{RX}	±3	dB	-24	-2	dBm	

Block-Diagram-of-Transceiver

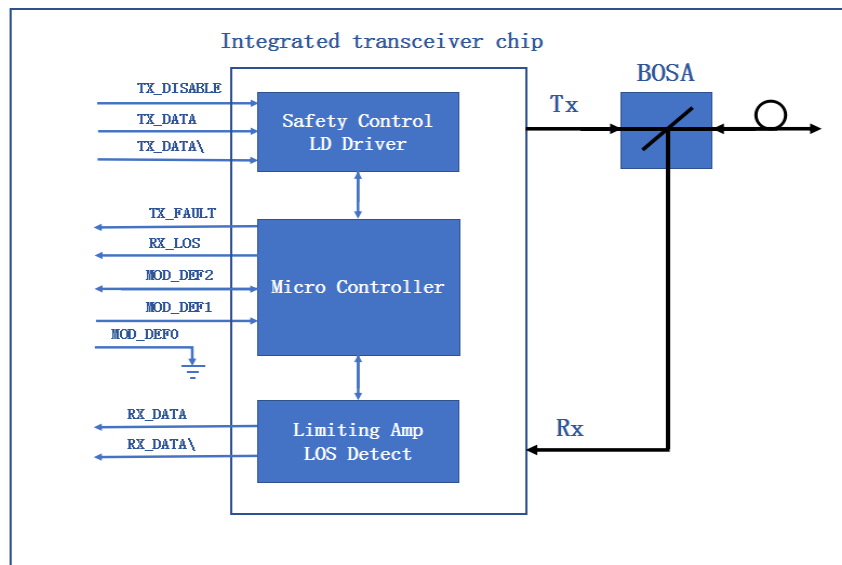

Functions Description

The transmitter is mainly composed of a laser driver part of the intelligent transceiver chip and a light emitting component in a BOSA (Bidirectional Optical Transceiver Assembly). The light-emitting component of BOSA includes a 1310nm DFB laser and a backlight photodetection chip. When the module is working, the input signal is connected to the intelligent transceiver chip, at this time, the laser driver of the intelligent transceiver chip supplies the bias current and the modulation current to the laser. The intelligent transceiver chip simultaneously uses an automatic optical power control (APC) feedback loop to maintain a constant average optical power of the laser output. The purpose is to eliminate the change of the output optical signal due to temperature changes and aging of the light source device. When the transmitter enable pin (TX_Disable) is high (TTL logic "1"), the laser output is turned off. When TX_Disable is low (TTL logic "0"), the laser will turn on within 1ms. When the transmitter fault signal (TX_Fault) is reported as high, indicates a transmitter failure caused by the transmitter's bias current or transmitted optical power or laser tube temperature exceeding a preset alarm threshold. Low indicates normal operation.

The receiver is mainly composed of a limiting amplifier part of the intelligent transceiver chip and a light receiving component part in the BOSA. The light receiving components of BOSA includes a PIN photodetector and a transimpedance amplifier chip. When the BOSA detects the incident light signal, it will be converted into a photo-generated current by the PIN photodetector, the photo-generated current is converted into an electrical signal after passing through the transimpedance amplifier. The electrical signal is further amplified by the limiting amplifier of the intelligent transceiver chip, then outputs a fixed-amplitude electrical signal to the host. When the amplitude of the electrical signal received from the incident light conversion of the opposite optical transceiver module is lower than the set threshold, the module reports that the received signal is lost, the RX_LOS pin is high (logic "1"), which can be used to diagnose whether the physical signal is normal. The signal is operated in TTL level. The microprocessor inside the module monitors the module's operating voltage, temperature, transmitted optical power, re-ceived optical power, and laser bias current value in real time. The host acquires this information over a 2-wire serial bus.

Dimensions

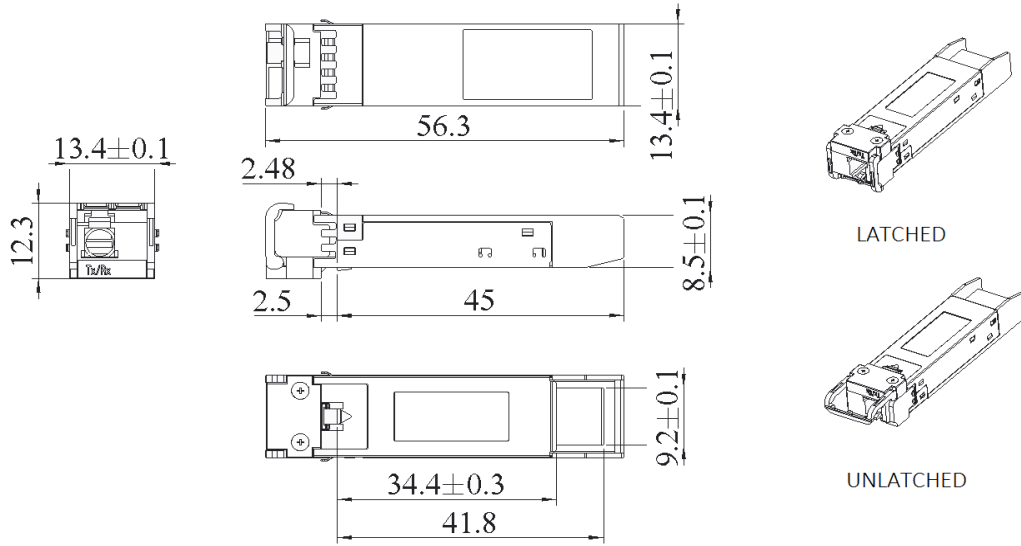

ALL DIMENSIONS ARE ±0.2mm UNLESS OTHERWISE SPECIFIED
UNIT: mm

Electrical Pad Layout

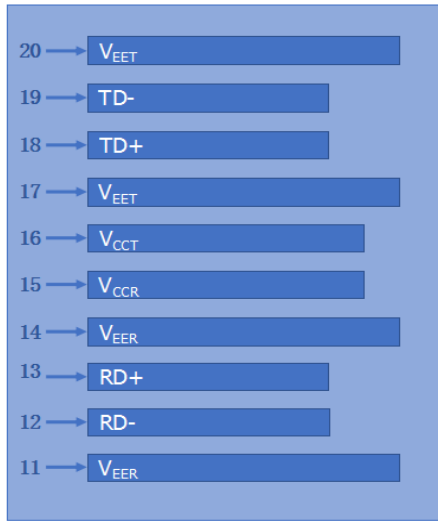

Top of Board

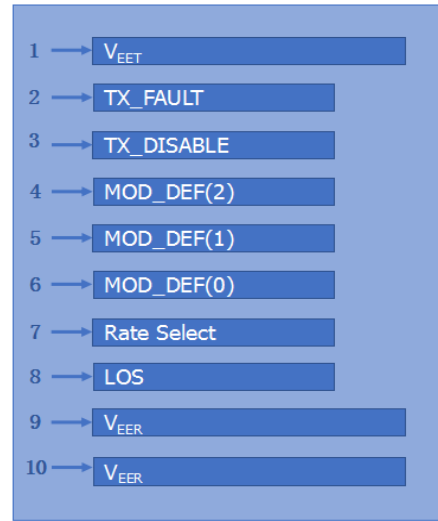

Bottom of Board

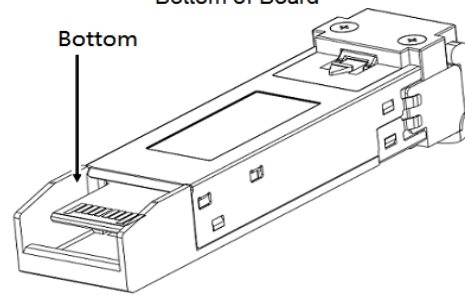
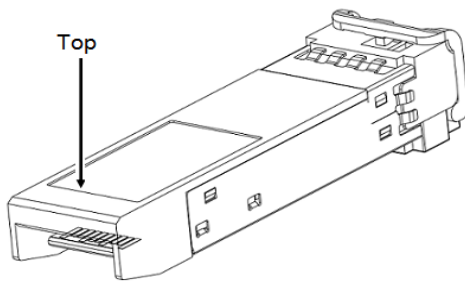

Pin Assignment

PIN #	Symbol	Description	Remarks
1	V _{EET}	Transmitter ground (common with receiver ground)	1
2	TX_FAULT	Transmitter Fault. Not supported	
3	TX_DISABLE	Transmitter Disable. Laser output disabled on high or open	2
4	MOD_DEF(2)	Module Definition 2. Data line for serial ID	3
5	MOD_DEF(1)	Module Definition 1. Clock line for serial ID	3
6	MOD_DEF(0)	Module Definition 0. Grounded within the module	3
7	Rate Select	No connection required	
8	LOS	Loss of Signal indication. Logic 0 indicates normal operation	4
9	V _{EER}	Receiver ground (common with transmitter ground)	1
10	V _{EER}	Receiver ground (common with transmitter ground)	1
11	V _{EER}	Receiver ground (common with transmitter ground)	1
12	RD-	Receiver Inverted DATA out. AC coupled	
13	RD+	Receiver Non-inverted DATA out. AC coupled	
14	V _{EER}	Receiver ground (common with transmitter ground)	1
15	V _{CCR}	Receiver power supply	
16	V _{CCT}	Transmitter power supply	
17	V _{EET}	Transmitter ground (common with receiver ground)	1
18	TD+	Transmitter Non-Inverted DATA in. AC coupled	
19	TD-	Transmitter Inverted DATA in. AC coupled	
20	V _{EET}	Transmitter ground (common with receiver ground)	1

Notes:

1. Circuit ground is isolated from chassis ground
2. Disabled: T_{DIS} > 2V or open, Enabled: T_{DIS} < 0.8V
3. Should Be pulled up with 4.7k –10k ohm on host board to a voltage between 2V and 3.6V
4. LOS is open collector output

References

1. IEEE standard 802.3. IEEE Standard Department, 2005.
2. Small Form Factor Pluggable (SFP) Transceiver Multi-Source Agreement (MSA), September 2000.
3. [Digital Diagnostics Monitoring Interface for Optical Transceivers –SFF-8472.](#)