

1.25Gb/s SFP BIDI Tx1490nm/Rx1570nm 80km Optical Transceiver

Product Features

- Up to 1.25Gb/s Data Links
- Hot-Pluggable
- Single LC connector
- Up to 80 km on 9/125 μ m SMF
- 1490nm DFB laser transmitter
- 1570nm PIN photo-detector
- Single +3.3V Power Supply
- Monitoring Interface Compliant with SFF-8472
- Maximum power dissipation <1W
- operating temperature range: -5° C to 85° C
- RoHS compliant and Lead Free

Applications

- 1000Base-ZX Ethernet
- Metro/Access Networks
- 1 \times Fibre Channel
- Other Optical Links

The AC-B-SFPBX80-E47-xx is a high performance, cost effective module which have a single LC optics interface. They are compatible with the Small Form Factor Pluggable

Multi-Sourcing Agreement (MSA) and Digital diagnostics functions are available via the 2-wire serial bus specified in SFF-8472. The receiver section uses a PIN receiver and the transmitter uses a 1490 nm DFB laser, up to 22dB link budge ensure this module 1000Base-ZX Ethernet 80km application.

Ordering Information

Part Number	Description
AC-B-SFPBX80-E47-xx	SFP 1.25Gbps BIDI Tx1490/Rx1570nm 80km optical transceiver extended temperature

Regulatory Compliance

Feature	Standard	Performance
Electromagnetic Interference (EMI)	FCC Part 15 Class B EN 55022:2010, Class B	Compatible with standards
Electromagnetic susceptibility (EMS)	EN 55024:2010	Compatible with standards
Laser Eye Safety	FDA 21CFR 1040.10 and 1040.11 EN60950, EN (IEC) 60825-1,2	Compatible with Class I laser product

Absolute Maximum Ratings

The operation in excess of any absolute maximum ratings might cause permanent damage to this module.

Parameter	Symbol	Min	Max	Unit	Notes
Supply Voltage	Vcc	-0.5	4.5	V	
Storage Temperature	Ts	-40	+85	°C	
Operating Humidity	-	0	85	%	

Recommended Operating Conditions and Power Supply Requirements

Parameter	Symbol	Min	Typical	Max	Unit	Notes
Operating Case Temperature	TOP	-5		85	°C	
Power Supply Voltage	Vcc	3.135	3.30	3.465	V	
Power Supply Current	Icc			250	mA	
Data Rate			1.25		Gbps	

Optical Characteristics

Parameter	Symbol	Min	Typical	Max	Unit	Notes
Transmitter						
Center Wavelength	λ_c	1480	1490	1500	nm	1
Spectral Width(-20dB)	σ			1	nm	
Optical Output Power	Pout	-2		+3	dBm	2
Optical Rise/Fall Time	tr / tf			260	ps	3
Extinction Ratio	ER	9			dB	
Deterministic Jitter Contribution	TX Δ DJ			56.5	ps	4
Total Jitter Contribution	TX Δ TJ			119	ps	
Eye Mask for Optical Output	Compliant with Eye Mask Defined in IEEE 802.3 standard					

Relative Intensity Noise	RIN			-120	dB/Hz	
Receiver						
Optical Input Wavelength	λ	1550	1570	1590	nm	
Optical Input Power	Pin	-24		-3	dBm	5.6
Receiver Reflectance		12			dB	
Receiver Overload	Pol			-3	dBm	5.6
RX Sensitivity	Sen			-24	dBm	5.6
RX_LOS Assert	LOS A	-34			dBm	
RX_LOS Deassert	LOS D			-25	dBm	
RX_LOS Hysteresis	LOS H		2	2.5	dB	

Notes:

1. Also specified to meet curves in FC-PI 13.0 Figures 18 and 19, which allow trade-off between wavelength spectral width.
2. Class 1 Laser Safety per FDA/CDRH and EN (IEC) 60825 regulations.
3. Unfiltered, 20-80%. Complies with IEEE 802.3 (Gig. E), FC 1x and 2x eye masks when filtered.
4. Measured with DJ-free data input signal. In actual application, output DJ will be the sum of input DJ and . DJ.
5. Measured with conformance signals defined in FC-PI 13.0 specifications.
6. Measured with PRBS 27-1 at 10-12 BER

Digital Diagnostic Functions

Parameter	Symbol	Min	Max	Unit	Notes
Temperature monitor absolute error	DMI_Temp	-3	+3	°C	
Supply voltage monitor absolute error	DMI_VCC	-0.1	+0.1	V	
TX power monitor absolute error	DMI_RX	-3	+3	dB	
RX power monitor absolute error	DMI_RX	-3	+3	dB	
Bias current monitor	DMI_Ibias	-10%	+10%	mA	

Recommended Circuit

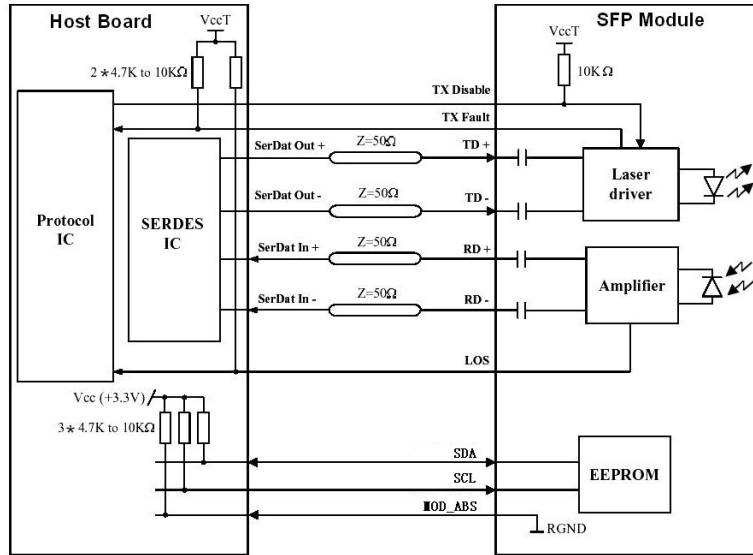

Mechanical Dimensions

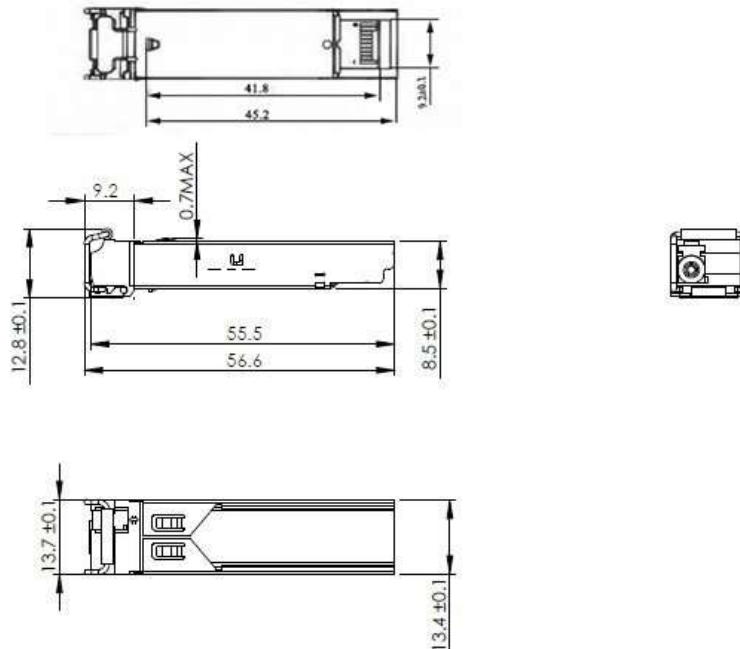

Pin Assignment and Description

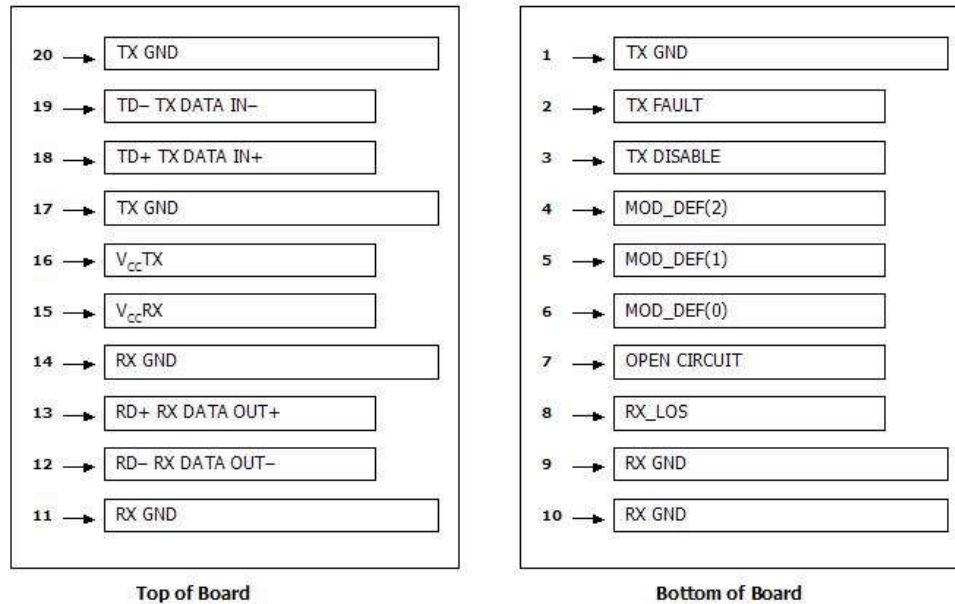

Pin Assignment

PIN #	Symbol	Description	Notes
1	VeeT	Transmitter Ground	1
2	TX Fault	Transmitter Fault Indication	
3	TX Disable	Transmitter Disable	2
4	MOD-DEF2	Module Definition	3
5	MOD-DEF1	Module Definition 1	3
6	MOD-DEF0	Module Definition 0	3
7	Rate Select	Not Connected	4
8	LOS	Loss of Signal	5
9	VeeR	Receiver Ground	1

10	VeeR	Receiver Ground	1
11	VeeR	Receiver Ground	1
12	RD-	Inv. Received Data Out	6
13	RD+	Received Data Out	6
14	VeeR	Receiver Ground	1
15	VccR	Receiver Power	1
16	VccT	Transmitter Power	
17	VeeT	Transmitter Ground	
18	TD+	Transmit Data In	6
19	TD-	Inv. Transmit In	6
20	VeeT	Transmitter Ground	

Notes:

1. Circuit ground is internally isolated from chassis ground.
2. Laser output disabled on TDIS >2.0V or open, enabled on TDIS <0.8V.
3. Should be pulled up with 4.7k - 10 kohms on host board to a voltage between 2.0V and 3.6V. MOD_DEF(0) pulls line low to indicate module is plugged in.
4. Rate select is not used
5. LOS is open collector output. Should be pulled up with 4.7k - 10kohms on host board to a voltage between 2.0V and 3.6V. Logic 0 indicates normal operation; logic 1 indicates loss of signal.
6. AC Coupled