

GPON OLT SFP C+ Transceiver Industrial Temperature

Product Features

- Single Fiber Transceiver with single mode SC/APC receptacle
- 1490nm continuous-mode 2.488Gb/s DFB transmitter
- 1310nm burst-mode 1.244Gb/s APD receiver
- Complies with ITU-T G.984.2 Class C+
- Digital Diagnostic Monitoring (DDM) with external calibrations
- LVPECL compatible data input /output
- LVTTTL for Tx disable input and Tx_fault output
- LVTTTL receiver Fast Burst Packet Detect indication
- Burst mode received signal strength indication (RSSI) function
- Complies with RoHS directive (2002/95/EC)

Applications

- Gigabit Passive Optical Network (GPON) OLT

This is a high performance transceiver module for single fiber communications. It is designed to meet ITU G.984.2 Class C+ requirements for optical line terminal (OLT) applications.

The 1490nm DFB LD transmitter has automatic power control (APC) function and temperature compensation circuitry to ensure stable optical power and extinction ratio over all operating temperature range. The transmitter meets Class 1 eye safety per IEC60825 and CDRH standards.

The receiver has a hermetically packaged APD-TIA (trans-impedance amplifier) pre-amplifier and a limiting amplifier with LVPECL compatible differential outputs. It features a Burst Packet Detect (SD) output which is LVTTTL compatible. The SD output will come high after receiving the burst packet.

The module provides digital diagnostic information of its operating conditions and status, including transmitting power, laser bias current, module temperature, and supply voltage.

Ordering Information

| Part Number | Description |
|---------------------|---|
| AC-B-SFPGPTA-C-I-xx | SFP GPON OLT C+ transceiver with full real-time digital diagnostic monitoring |

Regulatory Compliance

| Feature | Standard | Performance |
|--------------------------------------|--|---------------------------------------|
| Electromagnetic Interference (EMI) | FCC Part 15 Class B EN 55022:2010, Class B | Compatible with standards |
| Electromagnetic susceptibility (EMS) | EN 55024:2010 | Compatible with standards |
| Laser Eye Safety | FDA 21CFR 1040.10 and 1040.11 EN60950, EN (IEC) 60825-1,2 | Compatible with Class I laser product |

Absolute Maximum Ratings

The operation in excess of any absolute maximum ratings might cause permanent damage to this module.

| Parameter | Symbol | Min | Max | Unit | Notes |
|--|--------|-----|-----|------|-------|
| Storage Temperature | Tst | -40 | +85 | °C | |
| Operating relative humidity (Non- condensing) | RH | 5 | 90 | % | |
| Case Temperature (Operating) | TC | -40 | 85 | °C | |
| Input Voltage | - | GND | Vcc | V | |
| Power Supply Voltage | Vcc | 0 | 3.6 | V | |

Recommended Operating Conditions and Power Supply Requirements

| Parameter | Symbol | Min | Typical | Max | Unit | Notes |
|--|--------|-------|---------|-------|------|-------|
| Power Supply Voltage | Vcc | +3.14 | +3.3 | +3.46 | V | |
| Power Supply Current | Icc | - | 360 | 500 | mA | |
| Operating relative humidity (Non- condensing) | RH | 5 | | 85 | % | |
| Case Temperature (Operating) | TC | -40 | - | 85 | °C | |
| I2C clock frequency | | - | 100 | 400 | KHz | |
| Power consumption Max | - | - | - | 1.65 | W | |

1490nm Digital Transmitter E-O Characteristics

| Parameter | Symbol | Min | Typical | Max | Unit | Notes |
|--|-----------------------------------|------|---------|------|----------|-------|
| Support data rate | - | | 2.488 | | Gb/s | - |
| Center Wavelength | λ_c | 1480 | 1490 | 1500 | nm | 1 |
| Spectral Width (-20dB) | $\Delta\lambda_{-20dB}$ | - | - | 1 | nm | |
| Side Mode Suppression Ratio | SMSR | 30 | | | dB | |
| Average Optical Output Power | Po | 3 | - | 7 | dBm | |
| Extinction Ratio | Er | 8.2 | - | - | dB | |
| Output Power with Transmitter Disabled | Poff | | | -39 | dBm | |
| Output Eye Diagram | Compliant with ITU-T G.984.2 Mask | | | | | |
| Differential Input Voltage | VID | 600 | | 1600 | mV | |
| Differential Input Impedance | - | 80 | 100 | 120 | Ω | |

 Note 1: 2.488Gbps continuous-mode , PRBS2²³-1

1310 Burst-Mode Receiver Characteristics O-E Characteristics

| Parameter | Symbol | Min | Typical | Max | Unit | Notes |
|----------------------------|--------|-----------|---------|-------------|------|-------|
| Support data rate | | | 1.244 | | Gb/s | |
| Wavelength of Operation | - | 1290 | 1310 | 1330 | nm | - |
| Receiver Sensitivity | Sen. | - | - | -30 | dBm | 1 |
| Saturation Optical Power | Sat | -12 | - | - | dBm | 1 |
| Data Output Voltage - High | VOH | VccR-1.05 | - | VccR – 0.85 | V | - |
| Data Output Voltage - Low | VOL | VccR-1.84 | - | VccR – 1.60 | V | - |

 Note 1: Measured with 1310nm, 1.244Gbps PRBS223-1, burst-mode optical input, ER=10dB, BER=1x10⁻¹⁰, Single burst packet length is 40us and packet interval is 40us.

Digital Diagnostic Monitor Accuracy

| Parameter | Symbol | Min | Max | Unit | Notes |
|---------------------------------------|-----------|------|------|------|-------|
| Temperature monitor absolute error | DMI_Temp | -3 | +3 | °C | |
| Supply voltage monitor absolute error | DMI_VCC | -3% | 3% | V | |
| TX power monitor absolute error | DMI_RX | -3 | +3 | dB | |
| RX power monitor absolute error | DMI_RX | -3 | +3 | dB | |
| Bias current monitor | DMI_Ibias | -10% | +10% | mA | |

Recommended Circuit

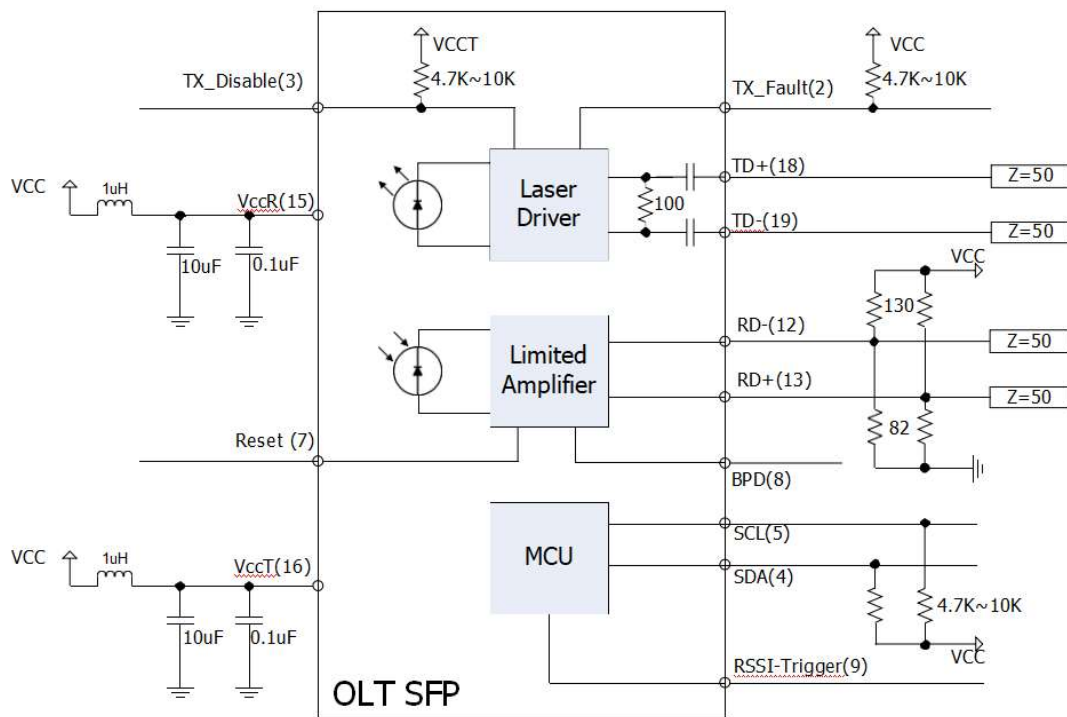

Timing Characteristics for Digital RSSI

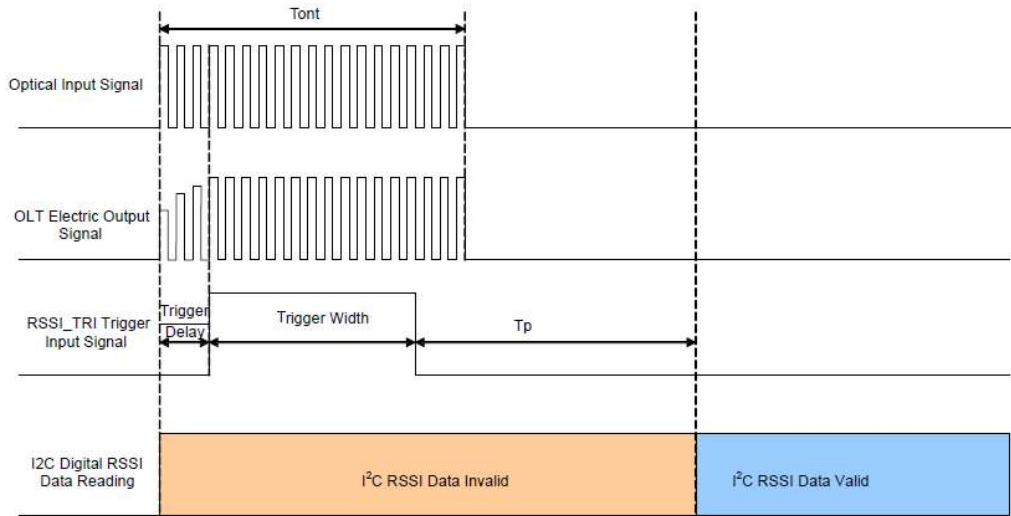

| PARAMETER | SYMBOL | MIN | TYP | MAX | UNITS |
|---------------------------|-----------|-----|-----|---------------------|-------|
| ONU Optical Signal Length | T_{ont} | 350 | - | - | ns |
| RSSI Trigger Delay | T_{tri} | 0 | 50 | - | ns |
| RSSI Trigger Signal Width | T_w | 300 | 350 | $T_{ont} - T_{tri}$ | ns |
| I2C read time | T_p | - | - | 500 | us |

Mechanical Dimensions

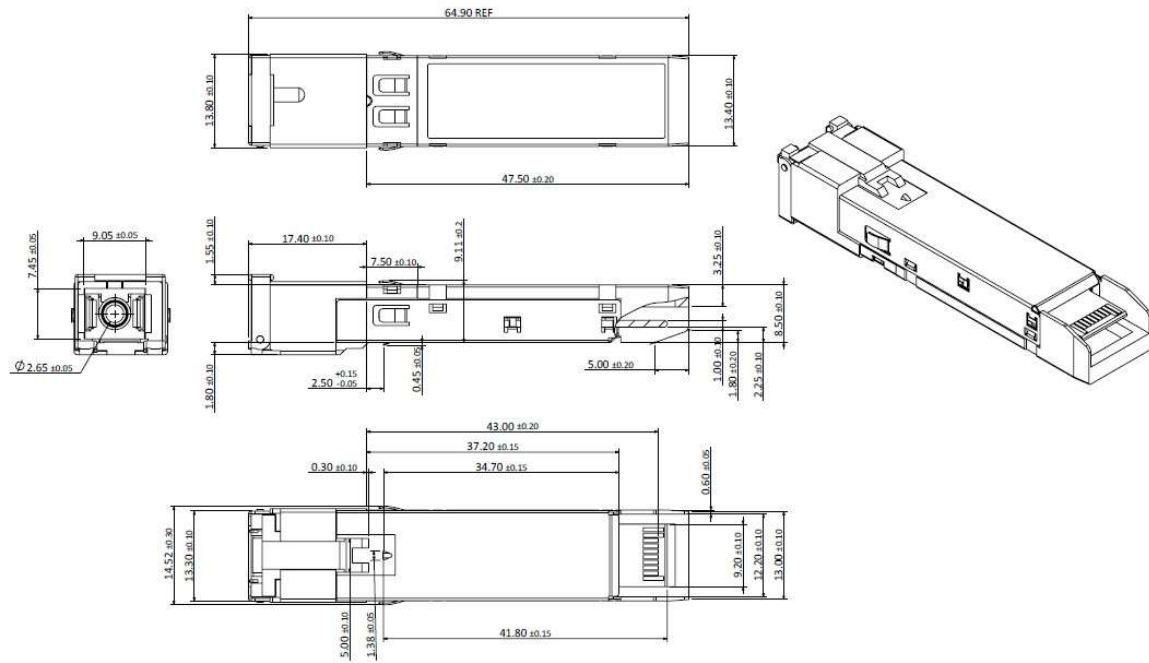

(Unit: mm)

Pin Assignment and Description

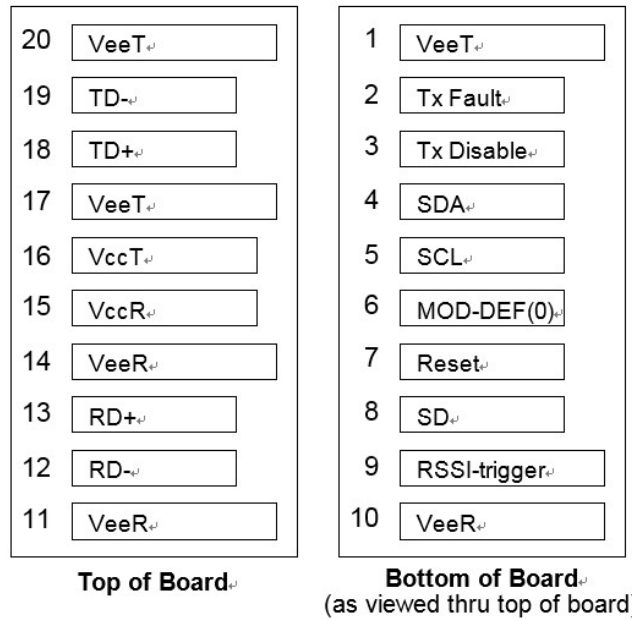

Pin Assignment

| PIN # | Logic | Name | Description | Notes |
|-------|-------|------------|--|--------|
| 1 | | VeeT | Transmitter Ground | Note 7 |
| 2 | LVTTL | TX_Fault | Transmitter Fault Indication | Note 1 |
| 3 | LVTTL | TX_Disable | Transmitter Disable | Note 2 |
| 4 | | SDA | ² I ² C Data | Note 3 |
| 5 | | SCL | ² I ² C Clock | Note 3 |
| 6 | | MOD-DEF(0) | Internally grounded | |

| | | | | |
|----|--------|--------------|-------------------------------|---------|
| 7 | LVTTTL | Reset | Receiver Reset | Note 4 |
| 8 | LVTTTL | SD | Burst Packet Detect | Note 5 |
| 9 | | RSSI_Trigger | RSSI Trigger Signal from Host | Note 6 |
| 10 | | VeeR | Receiver Ground | Note 7 |
| 11 | | VeeR | Receiver Ground | Note 7 |
| 12 | | RD- | Inv. Received Data Out | Note 8 |
| 13 | | RD+ | Received Data Out | Note 8 |
| 14 | | VeeR | Receiver Ground | Note 7 |
| 15 | | VccR | Receiver Power | Note 9 |
| 16 | | VccT | Transmitter Power | Note 9 |
| 17 | | VeeT | Transmitter Ground | Note 7 |
| 18 | | TD+ | Transmit Data In | Note 10 |
| 19 | | TD- | Inv. Transmit Data In | Note 10 |
| 20 | | VeeT | Transmitter Ground | Note 7 |

Notes:

1.TX Fault is an open collector output, which should be pulled up with a 4.7k~10k Ω resistor on the hostboard to a voltage between 2.0V and Vcc+0.3V. Logic 0 indicates normal operation; logic 1 indicates a laser fault of some kind. In the low state, the output will be pulled to less than 0.8V.

2.TX disable is an input that is used to shut down the transmitter optical output. It is pulled up within the module with a 4.7 – 10 K Ω resistor. It's states are:

Low (0 – 0.8V): Transmitter on

(>0.8, < 2.0V): Undefined

High (2.0 – 3.465V): Transmitter Disabled

Open: Transmitter Disabled

- 3.SDA and SCL is communication interface for I2C . They should be pulled up with a $4.7K - 10K \Omega$ resistor on the host board. The pull-up voltage should be Vcc.
- 4.Reset is a LVTTTL input which is used to clear receiver status before receiving the next burst packet.
- 5.BPD is a LVTTTL output. High level indicates that burst packet is detected by the receiver.
- 6.RSSI_Trigger is a LVTTTL input from host for starting ADC of digital RSSI circuit to sample the analog RSSI signal.
- 7.Vee is connected inside the SFP OLT transceiver.
- 8.RD- and RD+ are LVPECL differential outputs of the receiver, and externally DC-coupled to 100Ω differential lines at the user host board.
- 9.Vcc is the receiver and transmitter power supply, respectively. They are defined as $3.3V \pm 5\%$ at the SFP connector pin. Maximum suppl in order to maintain the required voltage at the SFP input pin with 3.3V supply voltage. Vcc is internally connected inside the SFP OLT transceiver.
- 10.TD- and TD+ are the differential transmitter inputs. They are AC coupled differential lines with 100Ω differential termination inside the module. The AC coupling is done inside the module and is thus not required on the host board.