

GPON OLT SFP C+ Transceiver Industrial Temperature

Product Features

- Single Fiber Transceiver with single mode SC/UPC receptacle
- 1490nm continuous-mode 2.488Gb/s DFB transmitter
- 1310nm burst-mode 1.244Gb/s APD receiver
- Complies with ITU-T G.984.2 Class C+
- Digital Diagnostic Monitoring (DDM) with external calibrations
- LVPECL compatible data input /output
- LVTTTL for Tx disable input and Tx_fault output
- LVTTTL receiver Fast Burst Packet Detect indication
- Burst mode received signal strength indication (RSSI) function
- Complies with RoHS directive (2002/95/EC)

Applications

- Gigabit Passive Optical Network (GPON) OLT

This is a high performance transceiver module for single fiber communications. It is designed to meet ITU G.984.2 Class C+ requirements for optical line terminal (OLT) applications.

The 1490nm DFB LD transmitter has automatic power control (APC) function and temperature compensation circuitry to ensure stable optical power and extinction ratio over all operating temperature range. The transmitter meets Class 1 eye safety per IEC60825 and CDRH standards.

The receiver has a hermetically packaged APD-TIA (trans-impedance amplifier) pre-amplifier and a limiting amplifier with LVPECL compatible differential outputs. It features a Burst Packet Detect (SD) output which is LVTTTL compatible. The SD output will come high after receiving the burst packet.

The module provides digital diagnostic information of its operating conditions and status, including transmitting power, laser bias current, module temperature, and supply voltage.

Ordering Information

Part Number	Description
AC-B-SFPGPTU-C-I-xx	SFP GPON OLT C+ transceiver with full real-time digital diagnostic monitoring

Regulatory Compliance

Feature	Standard	Performance
Electromagnetic Interference (EMI)	FCC Part 15 Class B EN 55022:2010, Class B	Compatible with standards
Electromagnetic susceptibility (EMS)	EN 55024:2010	Compatible with standards
Laser Eye Safety	FDA 21CFR 1040.10 and 1040.11 EN60950, EN (IEC) 60825-1,2	Compatible with Class I laser product

Absolute Maximum Ratings

The operation in excess of any absolute maximum ratings might cause permanent damage to this module.

Parameter	Symbol	Min	Max	Unit	Notes
Storage Temperature	Tst	-40	+85	°C	
Operating relative humidity (Non- condensing)	RH	5	90	%	
Case Temperature (Operating)	TC	-40	85	°C	
Input Voltage	-	GND	Vcc	V	
Power Supply Voltage	Vcc	0	3.6	V	

Recommended Operating Conditions and Power Supply Requirements

Parameter	Symbol	Min	Typical	Max	Unit	Notes
Power Supply Voltage	Vcc	+3.14	+3.3	+3.46	V	
Power Supply Current	Icc	-	360	500	mA	
Operating relative humidity (Non- condensing)	RH	5		85	%	
Case Temperature (Operating)	TC	-40	-	85	°C	
I2C clock frequency		-	100	400	KHz	
Power consumption Max	-	-	-	1.65	W	

1490nm Digital Transmitter E-O Characteristics

Parameter	Symbol	Min	Typical	Max	Unit	Notes
Support data rate	-		2.488		Gb/s	-
Center Wavelength	λ_c	1480	1490	1500	nm	1
Spectral Width (-20dB)	$\Delta\lambda_{-20dB}$	-	-	1	nm	
Side Mode Suppression Ratio	SMSR	30			dB	
Average Optical Output Power	Po	3	-	7	dBm	
Extinction Ratio	Er	8.2	-	-	dB	
Output Power with Transmitter Disabled	Poff			-39	dBm	
Output Eye Diagram	Compliant with ITU-T G.984.2 Mask					
Differential Input Voltage	VID	600		1600	mV	
Differential Input Impedance	-	80	100	120	Ω	

 Note 1: 2.488Gbps continuous-mode , PRBS2²³-1

1310 Burst-Mode Receiver Characteristics O-E Characteristics

Parameter	Symbol	Min	Typical	Max	Unit	Notes
Support data rate			1.244		Gb/s	
Wavelength of Operation	-	1290	1310	1330	nm	-
Receiver Sensitivity	Sen.	-	-	-30	dBm	1
Saturation Optical Power	Sat	-12	-	-	dBm	1
Data Output Voltage - High	VOH	VccR-1.05	-	VccR – 0.85	V	-
Data Output Voltage - Low	VOL	VccR-1.84	-	VccR – 1.60	V	-

 Note 1: Measured with 1310nm, 1.244Gbps PRBS223-1, burst-mode optical input, ER=10dB, BER=1x10⁻¹⁰, Single burst packet length is 40us and packet interval is 40us.

Digital Diagnostic Monitor Accuracy

Parameter	Symbol	Min	Max	Unit	Notes
Temperature monitor absolute error	DMI_Temp	-3	+3	°C	
Supply voltage monitor absolute error	DMI_VCC	-3%	3%	V	
TX power monitor absolute error	DMI_RX	-3	+3	dB	
RX power monitor absolute error	DMI_RX	-3	+3	dB	
Bias current monitor	DMI_Ibias	-10%	+10%	mA	

Recommended Circuit

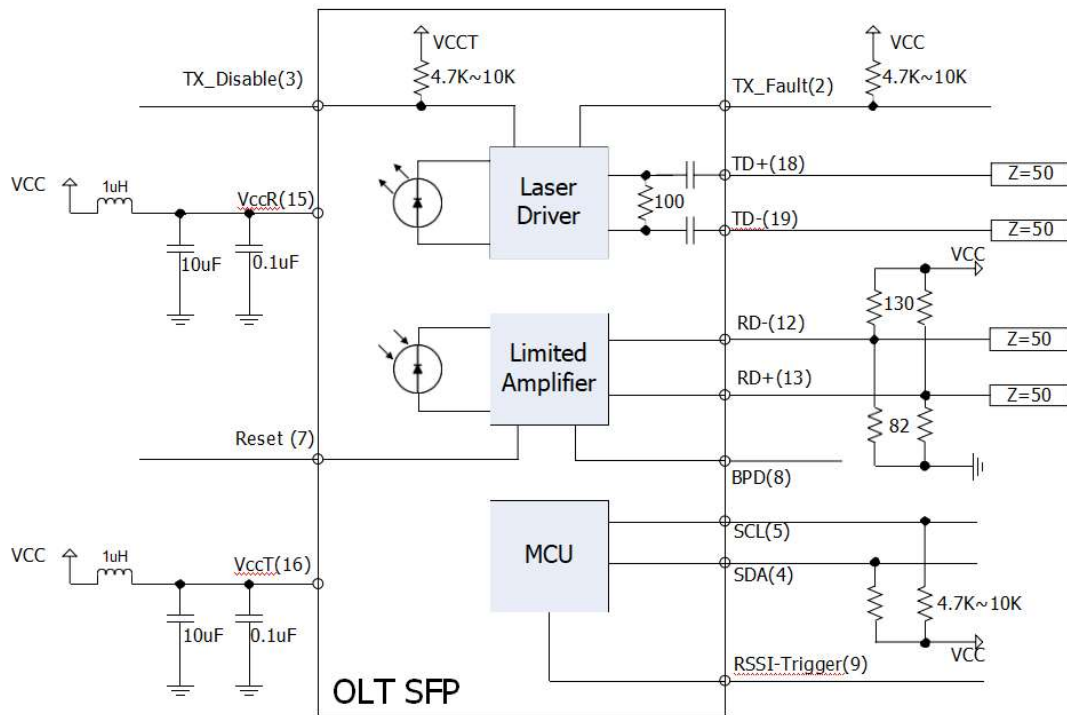

Timing Characteristics for Digital RSSI

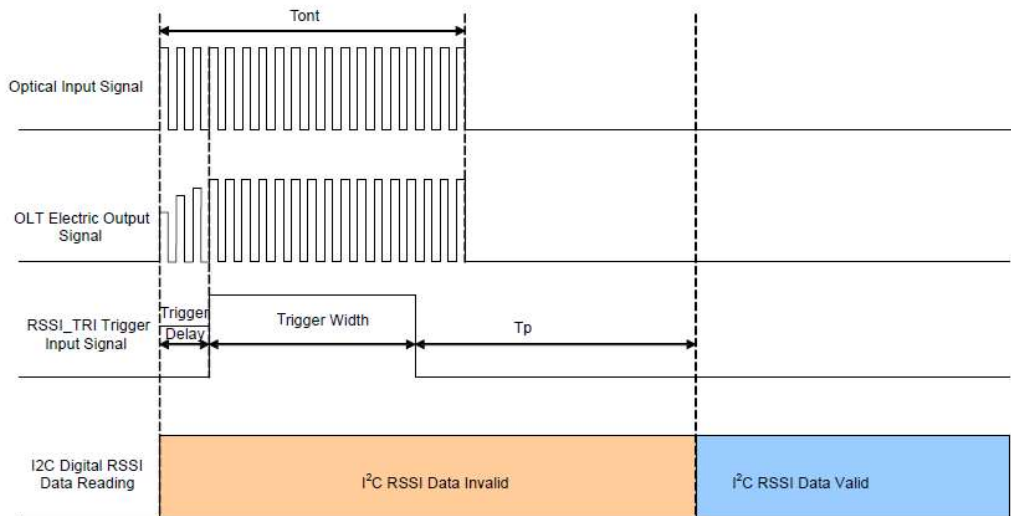

PARAMETER	SYMBOL	MIN	TYP	MAX	UNITS
ONU Optical Signal Length	T_{ont}	350	-	-	ns
RSSI Trigger Delay	T_{tri}	0	50	-	ns
RSSI Trigger Signal Width	T_w	300	350	$T_{ont} - T_{tri}$	ns
I2C read time	T_p	-	-	500	us

Mechanical Dimensions

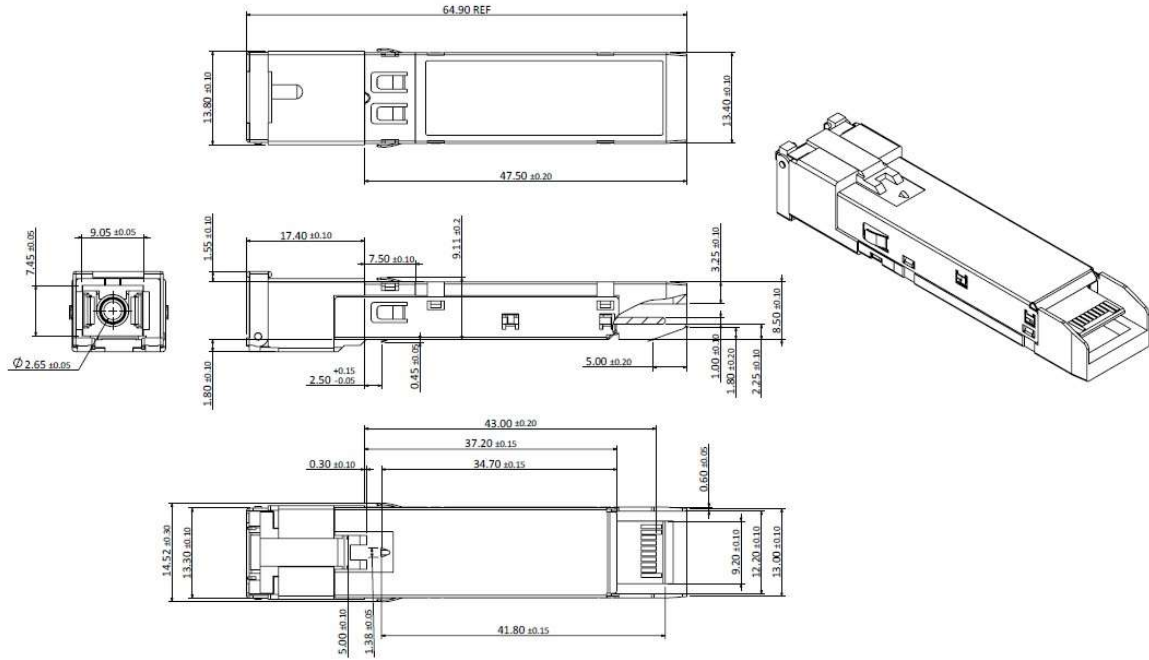

(Unit: mm)

Pin Assignment and Description

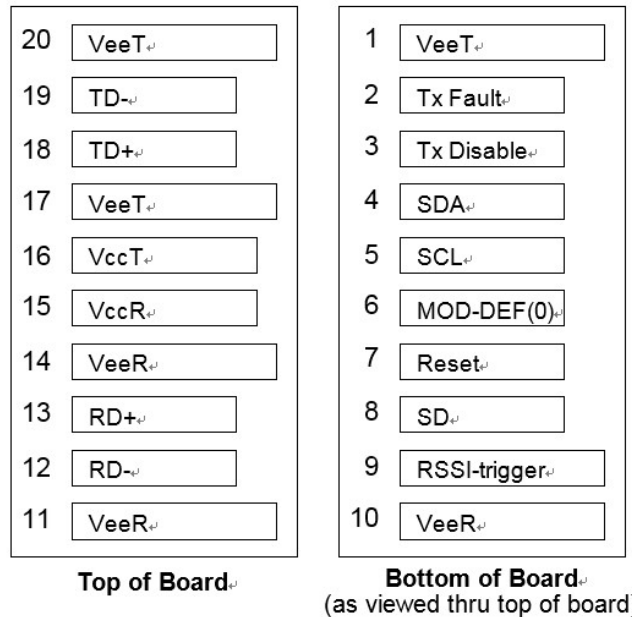

Pin Assignment

PIN #	Logic	Name	Description	Notes
1		VeeT	Transmitter Ground	Note 7
2	LVTTL	TX_Fault	Transmitter Fault Indication	Note 1
3	LVTTL	TX_Disable	Transmitter Disable	Note 2
4		SDA	² I ² C Data	Note 3
5		SCL	² I ² C Clock	Note 3
6		MOD-DEF(0)	Internally grounded	

7	LVTTL	Reset	Receiver Reset	Note 4
8	LVTTL	SD	Burst Packet Detect	Note 5
9		RSSI_Trigger	RSSI Trigger Signal from Host	Note 6
10		VeeR	Receiver Ground	Note 7
11		VeeR	Receiver Ground	Note 7
12		RD-	Inv. Received Data Out	Note 8
13		RD+	Received Data Out	Note 8
14		VeeR	Receiver Ground	Note 7
15		VccR	Receiver Power	Note 9
16		VccT	Transmitter Power	Note 9
17		VeeT	Transmitter Ground	Note 7
18		TD+	Transmit Data In	Note 10
19		TD-	Inv. Transmit Data In	Note 10
20		VeeT	Transmitter Ground	Note 7

Notes:

1. TX Fault is an open collector output, which should be pulled up with a $4.7k \sim 10k \Omega$ resistor on the hostboard to a voltage between 2.0V and $V_{cc} + 0.3V$. Logic 0 indicates normal operation; logic 1 indicates a laser fault of some kind. In the low state, the output will be pulled to less than 0.8V.

2. TX disable is an input that is used to shut down the transmitter optical output. It is pulled up within the module with a $4.7 - 10 K \Omega$ resistor. Its states are:

Low (0 - 0.8V): Transmitter on

(>0.8, < 2.0V): Undefined

High (2.0 - 3.465V): Transmitter Disabled

Open: Transmitter Disabled

- 3.SDA and SCL is communication interface for I2C . They should be pulled up with a $4.7K - 10K \Omega$ resistor on the host board. The pull-up voltage should be Vcc.
- 4.Reset is a LVTTTL input which is used to clear receiver status before receiving the next burst packet.
- 5.BPD is a LVTTTL output. High level indicates that burst packet is detected by the receiver.
- 6.RSSI_Trigger is a LVTTTL input from host for starting ADC of digital RSSI circuit to sample the analog RSSI signal.
- 7.Vee is connected inside the SFP OLT transceiver.
- 8.RD- and RD+ are LVPECL differential outputs of the receiver, and externally DC-coupled to 100Ω differential lines at the user host board.
- 9.Vcc is the receiver and transmitter power supply, respectively. They are defined as $3.3V \pm 5\%$ at the SFP connector pin. Maximum suppl in order to maintain the required voltage at the SFP input pin with $3.3V$ supply voltage. Vcc is internally connected inside the SFP OLT transceiver.
- 10.TD- and TD+ are the differential transmitter inputs. They are AC coupled differential lines with 100Ω differential termination inside the module. The AC coupling is done inside the module and is thus not required on the host board.