

622Mbps SFP 40km Optical Transceiver

Product Features

- Up to 622Mb/s Data Links
- Hot-Pluggable
- 1550nm DFB laser transmitter
- PIN receiver
- Duplex LC connector
- RoHS compliant and Lead Free
- Up to 40 km on 9/125 μ m SMF
- Monitoring Interface Compliant with SFF-8472
- Low power dissipation <1W typically
- operating temperature range: -5° C to 85° C

Applications

- 622Mbps Optical systems
- Fast Ethernet
- SONET OC-12 LR1
- Other Optical links

The AC-B-SFPO12-ELR1-xx is a high performance, cost effective module which have a Duplex LC optics interface. Standard AC coupled CML for high speed signal and LVTTTL control and monitor signals. The receiver section uses a PIN receiver and the transmitter uses 1550nm DFB laser, ensure this module 622Mbps 40km application.

Ordering Information

Part Number	Description
AC-B-SFPO12-ELR1-xx	SFP 622Mbps 1550nm 40km optical transceiver extended temperature

Regulatory Compliance

Feature	Standard	Performance
Electromagnetic Interference (EMI)	FCC Part 15 Class B	Compatible with standards
	EN 55022:2010, Class B	
Electromagnetic susceptibility (EMS)	EN 55024:2010	Compatible with standards
Laser Eye Safety	FDA 21CFR 1040.10 and 1040.11	Compatible with Class I laser product
	EN60950, EN (IEC) 60825-1,2	

Absolute Maximum Ratings

The operation in excess of any absolute maximum ratings might cause permanent damage to this module.

Parameter	Symbol	Min	Max	Unit	Notes
Storage Temperature	TS	-40	85	°C	
Operating Case Temperature	TOP	-5	85	°C	
Relative Humidity (non-condensation)	RH	0	85	%	

Recommended Operating Conditions and Power Supply Requirements

Parameter	Symbol	Min	Typical	Max	Unit	Notes
Supply Voltage	VCC		3.135		3.465	V
Supply Current	Icc				300	mA
Inrush Current	Isurge				Icc+30	mA
Maximum Power	Pmax				1	W
Case operating Temperature	TC	-5			+85	°C

Electrical Characteristics

The following electrical characteristics are defined over the Recommended Operating Environment unless otherwise specified.

Parameter	Symbol	Min	Typical	Max	Unit	Notes
Supply Voltage	Vcc	3.135		3.465	V	
Supply Current	Icc			300	mA	
Inrush Current	Isurge			Icc+30	mA	
Maximum Power	Pmax			1.0	W	
Transmitter						
Input differential impedance	Rin	90	100	110	Ω	Ω
Single ended data input swing	Vin PP	250		1200	mVp-p	

Transmit Disable Voltage	VD	Vcc – 1.3		Vcc	V	2
Transmit Enable Voltage	VEN	Vee		Vee+ 0.8	V	
Transmit Disable Assert Time	Tdessert			10	us	
Receiver						
Single ended data output swing	Vout,pp	250		800	mv	3
Data output rise time	tr			260	ps	4
Data output fall time	tf			260	ps	4
LOS Fault	Vlosfault	Vcc – 0.5		VCC_host	V	5
LOS Normal	Vlos norm	Vee		Vee+0.5	V	5
Power Supply Rejection	PSR	100			mVpp	
Deterministic Jitter Contribution	RXΔDJ			51.7	ps	
Total Jitter Contribution	RXΔTJ			122.4	ps	

Note:

1. AC coupled.
2. Or open circuit.
3. Into 100 ohm differential termination.
4. 20 – 80 %
5. LOS is LVTTTL. Logic 0 indicates normal operation; logic 1 indicates no signal detected.

Optical Characteristics

All parameters are specified under the recommended operating conditions unless otherwise specified..

Parameter	Symbol	Min	Typical	Max	Unit	Notes
Transmitter						
Center Wavelength	λ_c	1480	1550	1580	nm	
Spectral Width(-20dB)	σ			1	nm	
Side Mode Suppression Ratio	SMSR	30			dB	
Optical Output Power	Pout	-2		3	dBm	
Optical Rise/Fall Time	tr / tf			260	ps	
Extinction Ratio	ER	9			dB	
Deterministic Jitter Contribution	TX Δ DJ			56.5	ps	
Total Jitter Contribution	TX Δ TJ			119	ps	
Receiver						
Optical Input Wavelength	·	1260		1580	nm	
Optical Input Power	Pin	-24		-3	dBm	
Receiver Reflectance		12			dB	
Receiver Overload	Pol			-3	dBm	
RX Sensitivity	Sen			-24	dBm	
RX_LOS Assert	LOS A	-45			dBm	
RX_LOS Deassert	LOS D			-33	dBm	
RX_LOS Hysteresis	LOS H	0.5			dB	
General Specifications						
Data Rate	BR		622		Mb/s	
Bit Error Rate	BER			10^{-12}		
Max. Supported Link Length on 9/125 μ m SMF@1.25Gb/s	LMAX		40		km	

Digital Diagnostic Functions

Parameter	Symbol	Min	Max	Unit	Notes
Temperature monitor absolute error	DMI_Temp	-3	+3	°C	
Supply voltage monitor absolute error	DMI_VCC	-0.1	+0.1	V	
TX power monitor absolute error	DMI_RX	-3	+3	dB	
RX power monitor absolute error	DMI_RX	-3	+3	dB	
Bias current monitor	DMI_Ibias	-10%	+10%	mA	

Recommended Circuit

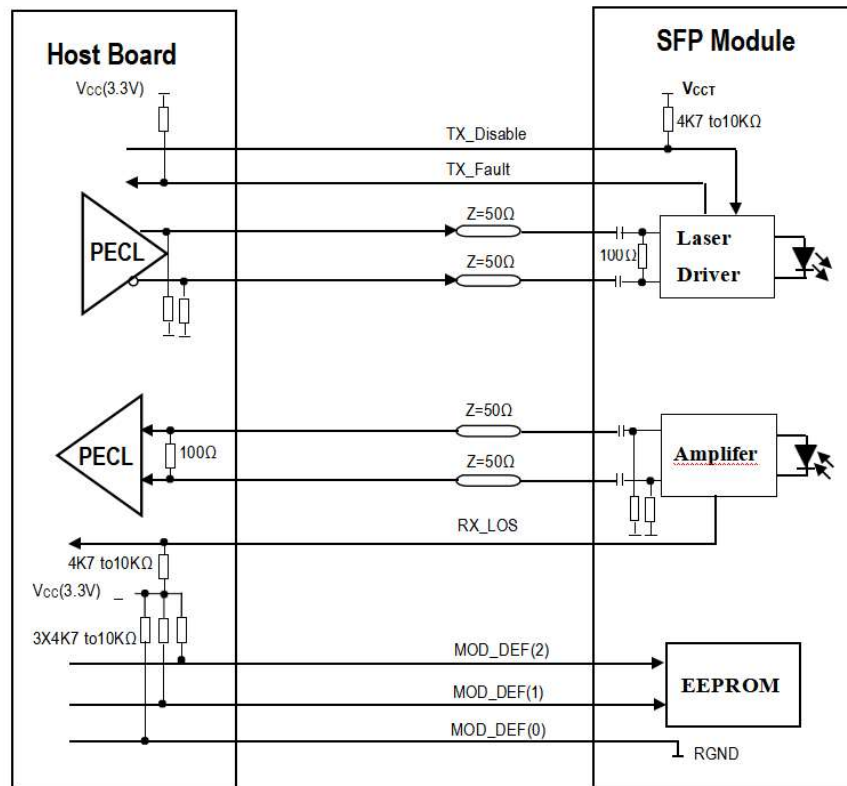

Mechanical Dimensions

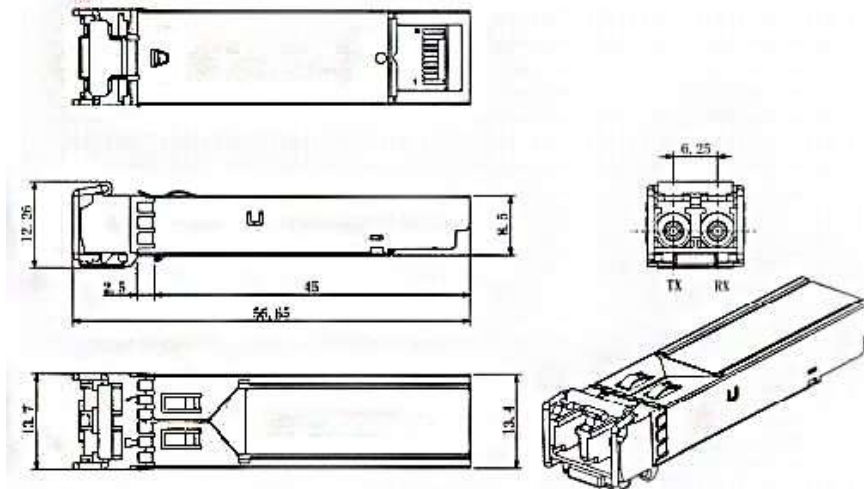

Pin Assignment and Description

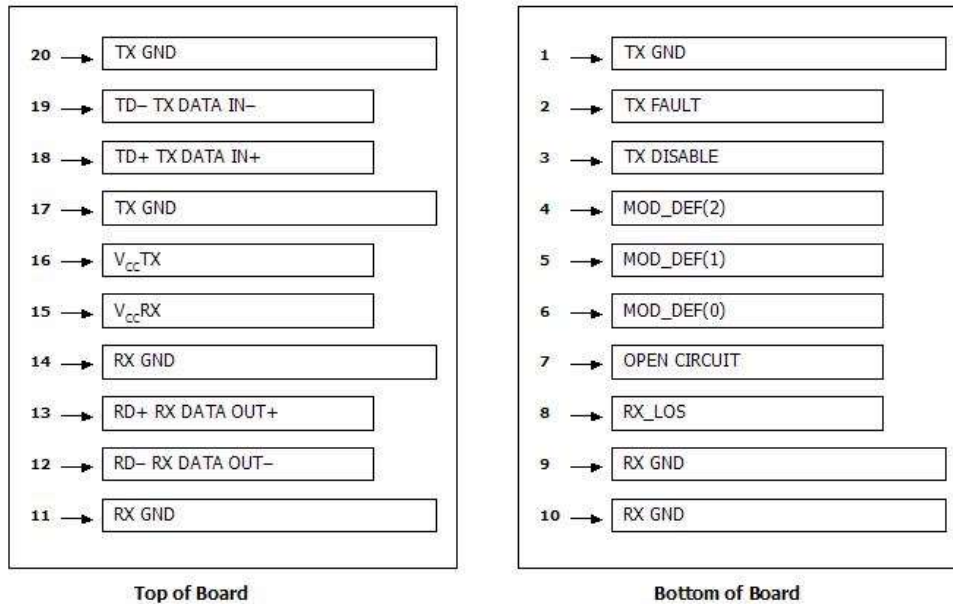

Pin Assignment

PIN #	Symbol	Description	Notes
1	VeeT	Transmitter Ground	1
2	TX Fault	Transmitter Fault Indication	
3	TX Disable	Transmitter Disable	2
4	MOD-DEF2	Module Definition	3
5	MOD-DEF1	Module Definition 1	3
6	MOD-DEF0	Module Definition 0	3
7	Rate Select	Not Connected	4
8	LOS	Loss of Signal	5
9	VeeR	Receiver Ground	1

10	VeeR	Receiver Ground	1
11	VeeR	Receiver Ground	1
12	RD-	Inv. Received Data Out	6
13	RD+	Received Data Out	6
14	VeeR	Receiver Ground	1
15	VccR	Receiver Power	1
16	VccT	Transmitter Power	
17	VeeT	Transmitter Ground	
18	TD+	Transmit Data In	6
19	TD-	Inv. Transmit In	6
20	VeeT	Transmitter Ground	

Notes:

1. Circuit ground is internally isolated from chassis ground.
2. Laser output disabled on TDIS >2.0V or open, enabled on TDIS <0.8V.
3. Should be pulled up with 4.7k - 10kohms on host board to a voltage between 2.0V and 3.6V. MOD_DEF(0) pulls line low to indicate module is plugged in.
4. Rate select is not used.
5. LOS is open collector output. Should be pulled up with 4.7k – 10kohms on host board to a voltage between 2.0V and 3.6V. Logic 0 indicates normal operation; logic 1 indicates loss of signal.
6. AC Coupled.