

10Gb/s SFP+ Tx1330nm/Rx1270nm 60km Bi-directional Transceiver

Overview

Axiom's AC-B-SFPPBI60-32-xx SFP+ optical transceivers are based on 10G Ethernet IEEE 802.3ae standard and SFF 8431 standard, providing a fast and reliable interface for 10G Ethernet applications. The product implements digital diagnostics via a 2-wire serial bus, compliant with the SFF-8472 standard.

Product Features

- Up to 10.7 Gb/s bi-directional data links
- Compliant with IEEE 802.3ae 10GBASE-LR/LW
- Compliant with 10GFC
- Compliant with SFF-8431
- Hot-pluggable SFP+ footprint
- 1330nm DFB laser transmitter and 1270nm APD Receiver
- Simplex LC connector
- Built-in digital diagnostic functions
- Up to 60km on SMF
- Single power supply 3.3V
- RoHS Compliant
- Operating temperature range: 0° C to 70° C

Applications

- 10GBASE-LR/LW Ethernet
- 10G FC

Ordering Information

Part Number	Description	Color on Clasp
AC-B-SFPPBI60-32-xx	10G SFP+ BIDI, Tx1330nm/Rx1270nm, LC Connectors 60km on SMF, with DOM function.	blue

General Specifications

Parameter	Symbol	Min	Typ	Max	Unit	Remarks
Data Rate	DR		10.3125		Gb/s	1
Bit Error Rate	BER			10^{-12}		
Operating Temperature	T _C	0		70	°C	2
Storage Temperature	T _{STO}	-40		85	°C	3
Supply Current	I _{CC}		260	280	mA	4
Input Voltage	V _{CC}	3.14	3.3	3.46	V	
Maximum Voltage	V _{MAX}	-0.5		4	V	4

Notes:

1. IEEE 802.3ae
2. Case temperature
3. Ambient temperature
4. For electrical power interface

Optical – Characteristics – Transmitter

$V_{CC}=3.14V$ to $3.46V$, $T_C=0^{\circ}C$ to $70^{\circ}C$

Parameter	Symbol	Min	Typ	Max	Unit	Remarks
Output Optical Power	P_{TX}	-1		5	dBm	1
Optical Center Wavelength	λ_C	1320	1330	1340	nm	
Extinction Ratio	ER	3	5.5		dB	
Spectral Width (-20dB)	$\Delta\lambda$			0.6	nm	
Side Mode Suppression Ratio	SMSR	30			dB	
Relative Intensity Noise	RIN			-128	dB/Hz	
Transmitter Dispersion Penalty	TDP			3.2	dB	
Launch Power of OFF Transmitter	P_{OUT_OFF}			-30	dBm	1
Transmitter Jitter	According to IEEE 802.3ae requirement					

Notes:

1. Average

Optical – Characteristics – Receiver

$V_{CC}=3.14V$ to $3.46V$, $T_C=0^{\circ}C$ to $70^{\circ}C$

Parameter	Symbol	Min	Typ	Max	Unit	Remarks
Average Receive Power	P_{RX}	-21.2		-9	dBm	
Optical Center Wavelength	λ_C	1260	1270	1290	nm	
Receiver Sensitivity @ 10.3Gb/s	R_{X_SEN1}			-19.2	dBm	1
Receiver Reflectance	TR_{RX}			-12	dB	
LOS Assert	LOS_A	-40			dBm	
LOS De-Assert	LOS_D			-22	dBm	
LOS Hysteresis	LOS_H	0.5			dB	

Notes:

1. Measured with the PRBS $2^{31}-1$ test mode, $BER < 10^{-12}$;

Electrical – Characteristics – Transmitter

V_{CC}=3.14V to 3.46V, T_C=0° C to 70° C

Parameter	Symbol	Min	Typ	Max	Unit	Remarks
Input differential impedance	R _{IN}		100		Ω	
Differential data input swing	V _{IN_PP}	180		700	mV	
Transmit disable voltage	V _D	2		V _{CC}	V	
Transmit enable voltage	V _{EN}	V _{EE}		V _{EE} + 0.8	V	

Electrical – Characteristics – Receiver

V_{CC}=3.14V to 3.46V, T_C=0° C to 70° C

Parameter	Symbol	Min	Typ	Max	Unit	Remarks
Differential data output swing	V _{OUT_PP}	300		850	mV	
Data output rise/fall time (20%-80%)	t _r /t _f	28			ps	
LOS Assert	V _{LOS_A}	2		V _{CC_HOST}	V	
LOS De-Assert	V _{LOS_D}	V _{EE}		V _{EE} + 0.5	V	

Digital Diagnostic Functions

AC-B-SFPPBI60-32-xx supports the 2-wire serial communication protocol as defined in SFF-8472. Digital diagnostic information is accessible over the 2-wire interface at the address 0xA2. Digital diagnostics for AC-B-SFPPBI60-32-xx are internally calibrated by default. The internal micro control unit accesses the device operating parameters in real time, such as transceiver temperature, laser bias current, transmitted optical power, received optical power and transceiver supply voltage. The module implements the alarm function of the SFF-8472, alerts the user when a particular operating parameter exceeds the factory-set normal range.

Block-Diagram-of-Transceiver

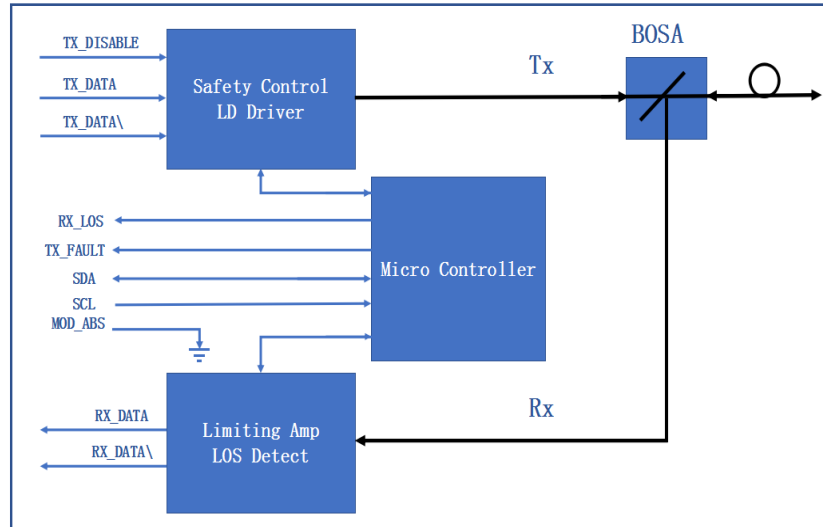

Functions Description

The transmitter is mainly composed of a laser driver and a light emitting component in a BOSA (Bidirectional Optical Transceiver Assembly). The light-emitting component of BOSA includes a 1330nm DFB laser and a backlight photo-detection chip. When the module is working, the electrical signal enters the module from the serial electrical interface, then input to the laser driver chip, at this time, the laser driver chip supplies the bias current and the modulation current to the laser. The laser driver chip simultaneously uses an automatic optical power control (APC) feedback loop to maintain a constant average optical power of the laser output. The purpose is to eliminate the change of the output optical signal due to temperature changes and aging of the light source device. When the transmitter enable pin (TX_Disable) is high (TTL logic “1”), the laser output is turned off. When TX_Disable is low (TTL logic “0”), the laser will turn on within 1ms. When the transmitter fault signal (TX_Fault) is reported as high, indicates a transmitter failure caused by the transmitter’s bias current or transmitted optical power or laser tube temperature exceeding a preset alarm threshold. Low indicates normal operation.

The receiver is mainly composed of a limiting amplifier chip and a light receiving component part in the BOSA. The light receiving components of BOSA includes a APD photodetector and a transimpedance amplifier chip. When the BOSA detects the incident light signal, it will be converted into a photo-generated current by the APD photodetector. The photo-generated current is converted into an electrical signal after passing through the transimpedance amplifier. The electrical signal is further amplified by the limiting amplifier, then outputs a fixed-amplitude electrical signal to the host. When the amplitude of the electrical signal received from the incident light conversion of the opposite optical transceiver module is lower than the set threshold, the module reports that the received signal is lost, the RX_LOS pin is high (logic “1”), which can be used to diagnose whether the physical signal is normal. The signal is operated in TTL level. The microprocessor inside the module monitors the module’s operating voltage, temperature, transmitted optical power, received optical power, and laser bias current value in real time. The host acquires this information over a 2-wire serial bus.

Dimensions

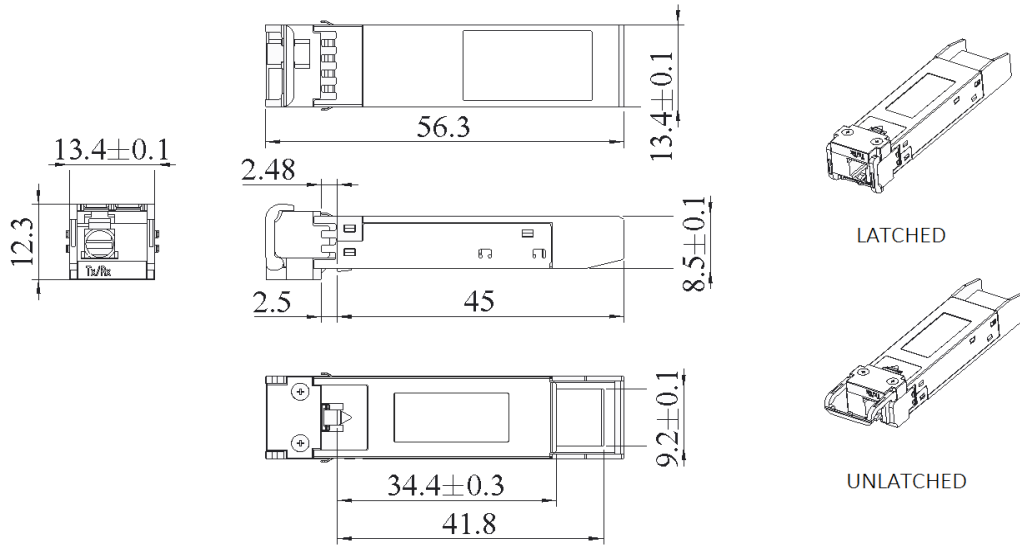

ALL DIMENSIONS ARE ± 0.2 mm UNLESS OTHERWISE SPECIFIED
UNIT: mm

Electrical Pad Layout

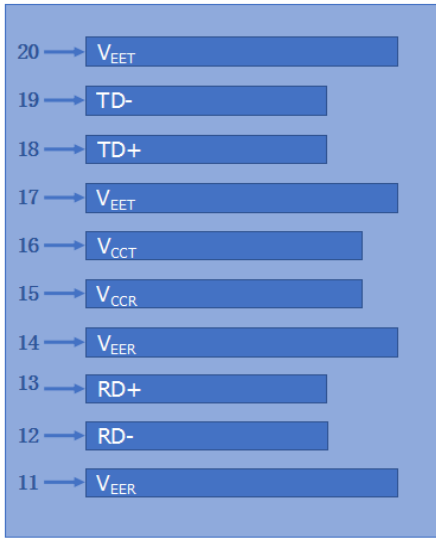

Top of Board

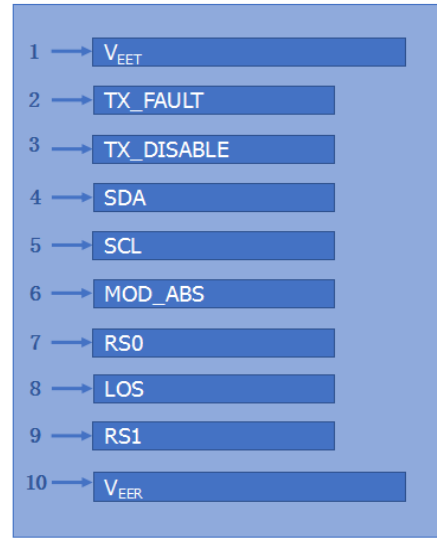
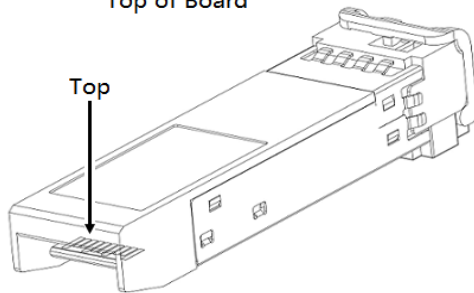

Bottom of Board

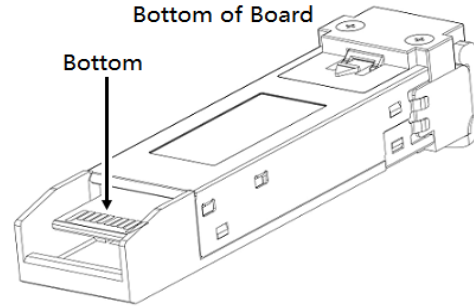

Pin Assignment

PIN #	Symbol	Description	Remarks
1	V _{EET}	Transmitter ground (common with receiver ground)	1
2	TX_FAULT	Transmitter Fault	
3	TX_DISABLE	Transmitter Disable. Laser output disabled on high or open	2
4	SDA	2-wire Serial Interface Data Line	3
5	SCL	2-wire Serial Interface Clock Line	3
6	MOD_ABS	Module Absent. Grounded within the module	3
7	RS0	No connection required	
8	LOS	Loss of Signal indication. Logic 0 indicates normal operation	4
9	RS1	No connection required	1
10	V _{EER}	Receiver ground (common with transmitter ground)	1
11	V _{EER}	Receiver ground (common with transmitter ground)	1
12	RD-	Receiver Inverted DATA out. AC coupled	
13	RD+	Receiver Non-inverted DATA out. AC coupled	
14	V _{EER}	Receiver ground (common with transmitter ground)	1
15	V _{CCR}	Receiver power supply	
16	V _{CCT}	Transmitter power supply	
17	V _{EET}	Transmitter ground (common with receiver ground)	1
18	TD+	Transmitter Non-Inverted DATA in. AC coupled	
19	TD-	Transmitter Inverted DATA in. AC coupled	
20	V _{EET}	Transmitter ground (common with receiver ground)	1

Notes:

1. Circuit ground is isolated from chassis ground
2. Disabled: T_{DIS} > 2V or open, Enabled: T_{DIS} < 0.8V
3. Should Be pulled up with 4.7k –10k ohm on host board to a voltage between 2V and 3.6V
4. LOS is open collector output

References

1. IEEE standard 802.3ae. IEEE Standard Department, 2005.
2. [Enhanced 8.5 and 10 Gigabit Small Form Factor Pluggable Module “ SFP+” SFF-8431.](#)
3. [Digital Diagnostics Monitoring Interface for Optical Transceivers –SFF-8472.](#)