

# 100Gb/s QSFP28 ER4 Lite Optical Transceiver

## Product Features

- Hot pluggable QSFP28 MSA form factor
- Compliant to Ethernet 100GBASE-ER4 Lite and OTN OTU4 4L1-9C1F Lite
- Up to 30km reach for G.652 SMF without FEC
- Up to 40km reach for G.652 SMF with FEC
- Single +3.3V power supply
- Operating case temperature: 0~70°C
- Transmitter: 4x28Gb/s LAN WDM TOSA (1295.56, 1300.05, 1304.58, 1309.14nm)
- Receiver: 4x28Gb/s APD ROSA
- Maximum power consumption 4.2W
- Duplex LC receptacle
- RoHS-6 compliant

## Applications

- 100GBASE-ER4 Ethernet Links
- OTN OTU4

This product is a 100Gb/s transceiver module designed for optical communication applications compliant to Ethernet IEEE 802.3ba standard. The module converts 4 input channels of 28Gb/s electrical data to 4 channels of LAN WDM optical signals and then multiplexes them into a single channel for 100Gb/s optical transmission. Reversely on the receiver side, the module de-multiplexes a 100Gb/s optical input into 4 channels of LAN WDM optical signals and then converts them to 4 output channels of electrical data.

The central wavelengths of the 4 LAN WDM channels are 1295.56, 1300.05, 1304.58 and 1309.14 nm as members of the LAN WDM wavelength grid defined in IEEE 802.3ba standard. The high performance LAN WDM transmitters and high sensitivity APD receivers provide superior performance for 100Gigabit applications up to 32km links and compliant to optical interface with 100GBASE-ER4 lite requirements.

The product is designed with form factor, optical/electrical connection and digital diagnostic interface according to the QSFP28 Multi-Source Agreement (MSA). It has been designed to meet the harshest external operating conditions including temperature, humidity and EMI interference.

## Ordering Information

Part Number	Description
AC-E-Q28E4L-xx	QSFP28 100G ER4 Lite optical transceiver with full real-time digital diagnostic monitoring and pull tab

## Regulatory Compliance

Feature	Standard	Performance
Electromagnetic Interference (EMI)	FCC Part 15 Class B EN 55022:2010, Class B	Compatible with standards
Electromagnetic susceptibility (EMS)	EN 55024:2010	Compatible with standards
Laser Eye Safety	FDA 21CFR 1040.10 and 1040.11 EN60950, EN (IEC) 60825-1,2	Compatible with Class I laser product

### Absolute Maximum Ratings

The operation in excess of any absolute maximum ratings might cause permanent damage to this module.

Parameter	Symbol	Min	Max	Unit	Notes
Storage Temperature	TS	-40	85	degC	
Operating Case Temperature	TOP	0	70	degC	
Power Supply Voltage	VCC	-0.5	3.6	V	
Relative Humidity (non-condensation)	RH	0	85	%	
Damage Threshold, each Lane	THd	-3		dBm	

### Recommended Operating Conditions and Power Supply Requirements

Parameter	Symbol	Min	Typical	Max	Unit	Notes
Operating Case Temperature	TOP	0		70	degC	Operating Case Temperature
Power Supply Voltage	VCC	3.135	3.3	3.465	V	Power Supply Voltage
Data Rate, each Lane			25.78125		Gb/s	Data Rate, each Lane
Control Input Voltage High		2		Vcc	V	Control Input Voltage High
Control Input Voltage Low		0		0.8	V	Control Input Voltage Low
Link Distance with G.652	D	0.002		40	km	Link Distance with G.652

### Electrical Characteristics

Parameter	Test Point	Min	Typical	Max	Unit	Notes
Power Consumption				4.2	W	
Supply Current	Icc			1.27	A	
Single-ended Input Voltage Tolerance (Note 1)		-0.3		4.0	V	Referred to TP1 signal common
AC Common Mode Input Voltage Tolerance		15			mV	RMS

Differential Input Voltage Swing	V <sub>in,pp</sub>			900	mVpp	
Differential Input Impedance	Z <sub>in</sub>	90	100	110	Ohm	
Single-ended Output Voltage		-0.3		4.0	V	Referred to signal common
AC Common Mode Output Voltage				7.5	mV	RMS
Differential Output Voltage Swing	V <sub>out,pp</sub>	300		850	mVpp	
Differential Output Impedance	Z <sub>out</sub>	90	100	110	Ohm	

**Notes:**

1. The single ended input voltage tolerance is the allowable range of the instantaneous input signals.

**Optical Characteristics**

Parameter	Symbol	Min	Typical	Max	Unit	Notes
Wavelength Assignment	L0	1294.53	1295.56	1296.59	nm	
	L1	1299.02	1300.05	1301.09	nm	
	L2	1303.54	1304.58	1305.63	nm	
	L3	1308.09	1309.14	1310.19	nm	
<b>Transmitter</b>						
Side Mode Suppression Ratio	SMSR	30			dB	
Total Average Launch Power	PT			12.5	dBm	
Average Launch Power, each Lane	PAVG	-2.5		6.5	dBm	
OMA, each Lane	POMA	0.5		6.5	dBm	1
Difference in Launch Power between any Two Lanes (OMA)	P <sub>tx,diff</sub>			3	dB	
Launch Power in OMA minus						

Transmitter and Dispersion Penalty (TDP), each Lane		-0.5			dBm	
TDP, each Lane	TDP			3.0	dB	
Extinction Ratio	ER	4.5			dB	
Optical Return Loss Tolerance	TOL			20	dB	
Transmitter Reflectance	RT			-12	dB	
Eye Mask{X1, X2, X3, Y1, Y2, Y3}		{0.25, 0.4, 0.45, 0.25, 0.28, 0.4}				
Average Launch Power OFF Transmitter, each Lane	Poff			-30	dBm	
<b>Receiver</b>						
Damage Threshold, each Lane	THd	-6			dBm	
Average Receive Power, each Lane		-20.5		-7	dBm	
Receive Power (OMA), each Lane				-7	dBm	
Receiver Sensitivity (OMA, 100GE), each Lane	SEN			-15	dBm	for BER = $1 \times 10^{-12}$
Receiver Sensitivity (OMA, 100GE), each Lane	SEN			-18.5	dBm	For BER = $5 \times 10^{-5}$
Receiver Sensitivity (OMA, OTU4), each Lane	SEN			-14	dBm	for BER = $5 \times 10^{-12}$
Receiver Sensitivity (OMA, OTU4), each Lane	SEN			-18	dBm	for BER = $5 \times 10^{-5}$
Difference in Receive Power between any Two Lanes (OMA)	Prx,diff			3.6	dB	
LOS Assert	LOSA		-26		dBm	
LOS Deassert	LOSD		-24		dBm	

LOS Hysteresis	LOSH	0.5			dB	
Receiver Electrical 3 dB upper Cutoff Frequency, each Lane	Fc			31	GHz	

**Conditions of Stress Receiver Sensitivity Test (Note 5)**

Vertical Eye Closure Penalty, each Lane			2.5		dB	
Stressed Eye J2 Jitter, each Lane			0.33		UI	
Stressed Eye J9 Jitter, each Lane			0.48		UI	

**Notes:**

1. Even if the TDP < 1 dB, the OMA min must exceed the minimum value specified here.

### Digital Diagnostic Functions

The following digital diagnostic characteristics are defined over the normal operating conditions unless otherwise specified.

Parameter	Symbol	Min	Max	Unit	Notes
Temperature monitor absolute error	DMI_Temp	-3	3	degC	Over operating temp
Supply voltage monitor absolute error	DMI_VCC	-0.1	0.1	V	Full operating range
Channel RX power monitor absolute error	DMI_RX	-3	3	dB	Per channel
Channel Bias current monitor	DMI_Ibias	-10%	10%	mA	Per channel
Channel TX power monitor absolute error	DMI_TX	-3	3	dB	Per channel

**Mechanical Dimension**

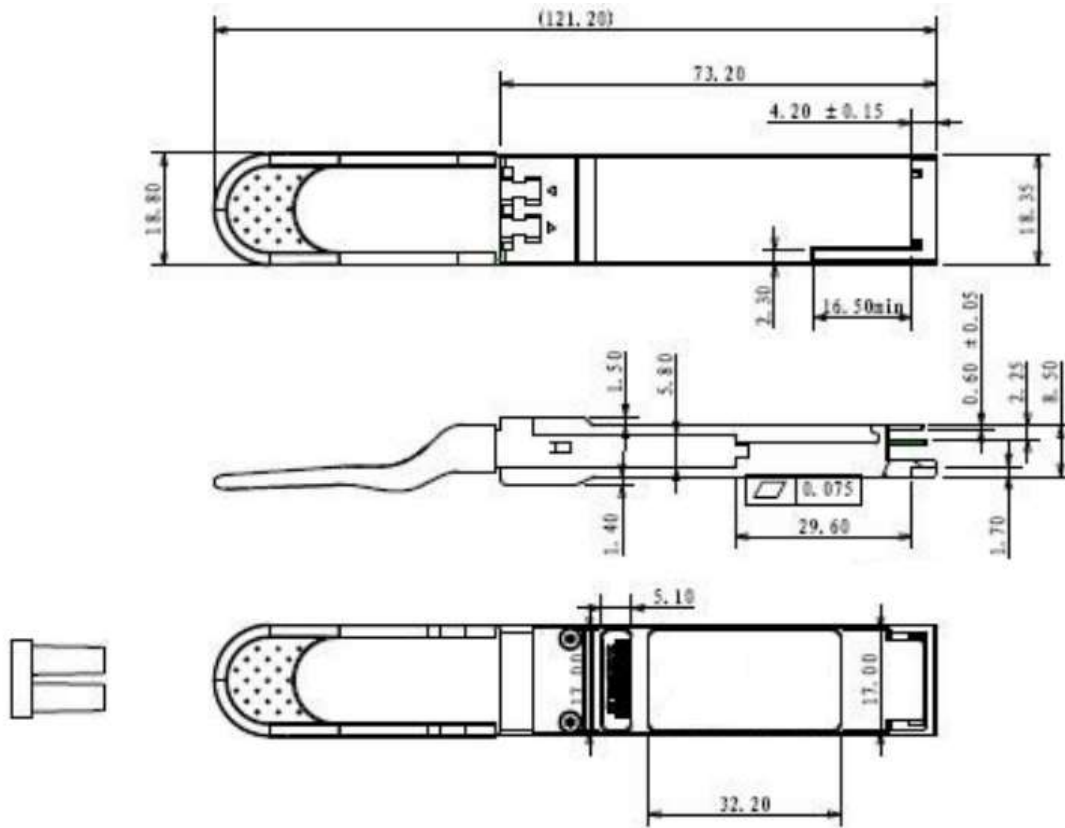

(Unit: mm)

**ESD**

This transceiver is specified as ESD threshold 1kV for SFI APDs and 2kV for all other electrical input APDs, tested per MIL-STD-883, Method 3015.4 /JESD22-A114-A (HBM). However, normal ESD precautions are still required during the handling of this module. This transceiver is shipped in ESD protective packaging. It should be removed from the packaging and handled only in an ESD protected environment.

**Laser Safety**

This is a Class 1 Laser Product according to IEC 60825-1:2007. This product complies with 21 CFR 1040.10 and 1040.11 except for deviations pursuant to Laser Notice No. 50, dated (June 24, 2007).

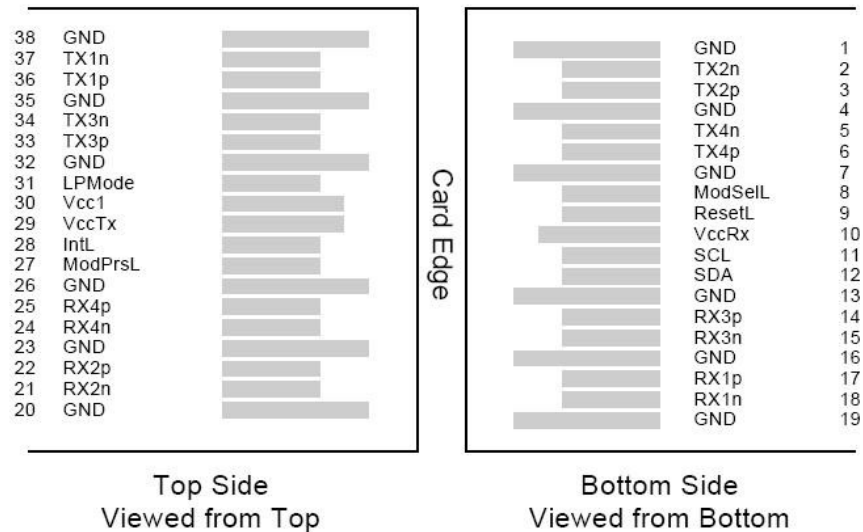
**PIN Assignment and Description**

PIN #	Logic	Symbol	Description	Notes
1		GND	Ground	
2	CML-I	Tx2n	Transmitter Inverted Data Input	
3	CML-I	Tx2p	Transmitter Non-Inverted Data output	
4		GND	Ground	
5	CML-I	Tx4n	Transmitter Inverted Data Input	
6	CML-I	Tx4p	Transmitter Non-Inverted Data output	
7		GND	Ground	
8	LVTLL-I	ModSelL	Module Select	
9	LVTLL-I	ResetL	Module Reset	
10		VccRx	+3.3V Power Supply Receiver	
11	LVC MOS-I/O	SCL	2-Wire Serial Interface Clock	
12	LVC MOS-I/O	SDA	2-Wire Serial Interface Data	
13		GND	Ground	
14	CML-O	Rx3p	Receiver Non-Inverted Data Output	

15	CML-O	Rx3n	Receiver Inverted Data Output
16		GND	Ground
17	CML-O	Rx1p	Receiver Non-Inverted Data Output
18	CML-O	Rx1n	Receiver Inverted Data Output
19		GND	Ground
20		GND	Ground
21	CML-O	Rx2n	Receiver Inverted Data Output
22	CML-O	Rx2p	Receiver Non-Inverted Data Output
23		GND	Ground
24	CML-O	Rx4n	Receiver Inverted Data Output
25	CML-O	Rx4p	Receiver Non-Inverted Data Output
26		GND	Ground
27	LVTTTL-O	ModPrsL	Module Present
28	LVTTTL-O	IntL	Interrupt
29		VccTx	+3.3 V Power Supply transmitter
30		Vcc1	+3.3 V Power Supply
31	LVTTTL-I	LPMODE	Low Power Mode
32		GND	Ground
33	CML-I	Tx3p	Transmitter Non-Inverted Data Input
34	CML-I	Tx3n	Transmitter Inverted Data Output
35		GND	Ground
36	CML-I	Tx1p	Transmitter Non-Inverted Data Input
37	CML-I	Tx1n	Transmitter Inverted Data Output
38		GND	Ground