

1.25Gb/s SFP (Small Form Pluggable) Long Wavelength (1310nm) Transceiver

Overview

Axiom's AC-F-SFPLX-I-xx SFP optical transceivers are based on the Gigabit Ethernet IEEE 802.3 standard and Fibre Channel FC-PI Rev.5.0, providing a fast and reliable interface for GE/FC applications. The product implements digital diagnostics via a 2-wire serial bus, compliant with the INF-8074i Small Form Factor Pluggable Multi-Source Agreement (MSA) and SFF-8472 standard.

Product Features

- Supports data rates of 1.25Gb/s
- Compliant with SFP MSA
- Hot-pluggable SFP footprint
- 1310nm FP laser transmitter
- Duplex LC connector
- Built-in digital diagnostic functions
- Up to 20km on 9/125um SMF
- Single power supply 3.3V
- RoHS Compliant
- Class 1 laser product complies with EN 60825-1
- Operating temperature range: -40° C to 85° C

Applications

- 1.25Gb/s Gigabit Ethernet
- 1.063Gb/s Fiber Channel

Ordering Information

Part Number	Description	Color on Clasp
AC-F-SFPLX-I-xx	GE/FC SFP 1310nm LC Connectors 20km on SMF, with DOM function.	Blue

General Specifications

Parameter	Symbol	Min	Typ	Max	Unit	Remarks
Data Rate	DR		1.25		Gb/s	1
	DR		1.062		Gb/s	2
Bit Error Rate	BER			10^{-12}		
Operating Temperature	T _C	-40		85	°C	3
Storage Temperature	T _{STO}	-40		100	°C	4
Supply Current	I _{CC}		175	300	mA	5
Input Voltage	V _{CC}	3.14	3.3	3.46	V	
Maximum Voltage	V _{MAX}	-0.5		4	V	5

Notes:

1. IEEE 802.3
2. FC-P1-2 Rev 5
3. Case temperature
4. Ambient temperature
5. For electrical power interface

Optical – Characteristics – Transmitter

V_{CC}=3.14V to 3.46V, T_C=-40° C to 85° C

Parameter	Symbol	Min	Typ	Max	Unit	Remarks
Output Optical Power	P _{TX}	-9.5		- 3	dBm	1
Optical Center Wavelength	λ _C	1270		1355	nm	
Optical Modulation Amplitude	OMA	174			μW	2
Extinction Ratio	ER	9			dB	
Spectral Width (RMS)	Δλ			3	nm	
Optical Rise/Fall Time (20%-80%)	t _r /t _f		150	260	ps	
Relative Intensity Noise	RIN			-120	dB/Hz	
Deterministic Jitter Contribution	DJ		20	60	ps	
Total Jitter Contribution	TJ		50	120	ps	

Notes:

1. Class 1 Product
2. Equivalent extinction ratio specification for FC

Optical – Characteristics – Receiver

V_{CC}=3.14V to 3.46V, T_C=-40° C to 85° C

Parameter	Symbol	Min	Typ	Max	Unit	Remarks
Receiver Overload	P _{OL}	0			dBm	
Optical Center Wavelength	λ _C	1260		1600	nm	
Receiver Sensitivity	R _{X_SEN}			-24	dBm	
Optical Return Loss	ORL	12			dB	
Receiver Electrical 3dB Upper cutoff frequency				1500	MHz	
LOS Assert	LOS _A	-33			dBm	
LOS De-Assert	LOS _D			-26	dBm	
LOS Hysteresis	LOS _H	0.5			dB	

Electrical – Characteristics – Transmitter

V_{CC}=3.14V to 3.46V, T_C=-40° C to 85° C

Parameter	Symbol	Min	Typ	Max	Unit	Remarks
Input differential impedance	R _{IN}		100		Ω	
Single ended data input swing	V _{IN_PP}	250		1200	mV	
Transmit disable voltage	V _D	V _{CC} -1.3		V _{CC}	V	
Transmit enable voltage	V _{EN}	V _{EE}		V _{EE} + 0.8	V	
Transmit disable assert time				10	μs	

Electrical – Characteristics – Receiver

V_{CC}=3.14V to 3.46V, T_C=-40° C to 85° C

Parameter	Symbol	Min	Typ	Max	Unit	Remarks
Single ended data output swing	V _{OUT_PP}	300	400	800	mV	
Data output rise/fall time (20%-80%)	t _r /t _f			300	ps	
LOS Fault	V _{LOS_A}	V _{CC} -0.5		V _{CC_HOST}	V	
LOS Normal	V _{LOS_D}	V _{EE}		V _{EE} + 0.5	V	

Digital Diagnostic Functions

The AC-F-SFPLX-I-xx supports the 2-wire serial communication protocol as defined in SFP MSA. Digital diagnostic information is accessible over the 2-wire interface at the address 0xA2. Digital diagnostics for AC-F-SFPLX-I-xx are internally calibrated by default. The internal micro control unit accesses the device operating parameters in real time, Such as transceiver temperature, laser bias current, transmitted optical power, received optical power and transceiver supply voltage. The module implements the alarm function of the SFP MSA, alerts the user when a particular operating parameter exceeds the factory-set normal range.

Parameter	Symbol	Accuracy	Units	Report Range	Unit	Remarks
Internal Calibration						
Temperature	Temp	±3	° C	-40	95	° C
Voltage	V _{CC}	±0.1	V	2.7	3.9	V
Bias Current	I _{bias}	±10	%	1	80	mA
Tx Power	P _{TX}	±3	dB	-12	0	dBm
Rx Power	P _{RX}	±3	dB	-30	0	dBm

Block-Diagram-of-Transceiver

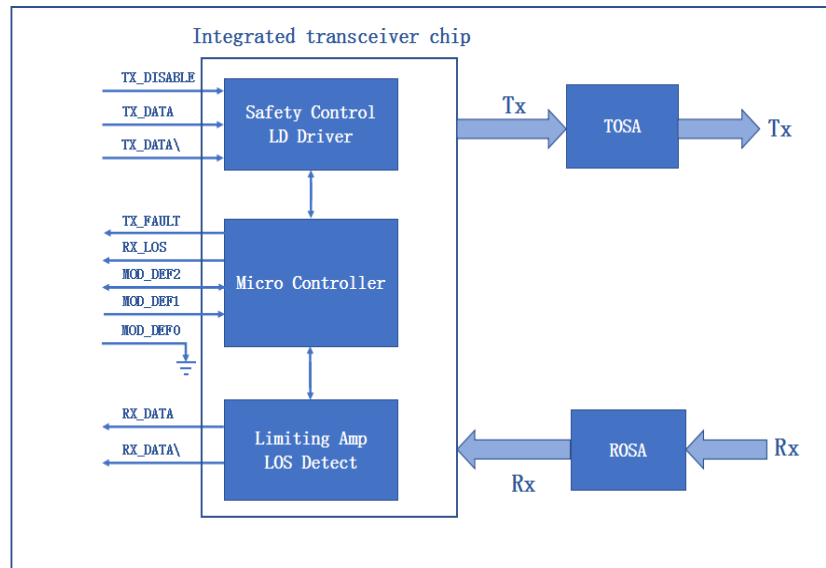

Functions Description

The transmitter is mainly composed of a laser driver part of the intelligent transceiver chip and a TOSA (light-emitting component), the TOSA includes a 1310nm FP Laser and a backlight photodetection chip. When the module is working, the input signal is connected to the intelligent transceiver chip, at this time, the laser driver of the intelligent transceiver chip supplies the bias current and the modulation current to the laser. The intelligent transceiver chip simultaneously uses an automatic optical power control (APC) feedback loop to maintain a constant average optical power of the laser output. The purpose is to eliminate the change of the output optical signal due to temperature changes and aging of the light source device. When the transmitter enable pin TX_Disable) is high (TTL logic "1"), the laser output is turned off. When TX_Disable is low (TTL logic "0"), the laser will turn on within 1ms. When the transmitter fault signal (TX_Fault) is reported as high, indicates a transmitter failure caused by the transmitter's bias current or transmitted optical power or laser tube temperature exceeding a preset alarm threshold. Low indicates normal operation.

The receiver is mainly composed of a limiting amplifier part of the intelligent transceiver chip and a ROSA (light-receiving component), the ROSA includes a PIN photodetector and a transimpedance amplifier chip. When the ROSA detects the incident light signal, it will be converted into a photo-generated current by the PIN photodetector. The photo-generated current is converted into an electrical signal after passing through the transimpedance amplifier. The electrical signal is further amplified by the limiting amplifier of the intelligent transceiver chip, then outputs a fixed-amplitude electrical signal to the host. When the amplitude of the electrical signal received from the incident light conversion of the opposite optical transceiver module is lower than the set threshold, the module reports that the received signal is lost, the RX_LOS pin is high (logic "1"), which can be used to diagnose whether the physical signal is normal. The signal is operated in TTL level. The microprocessor inside the module monitors the module's operating voltage, temperature, transmitted optical power, received optical power, and laser bias current value in real time. The host acquires this information over a 2-wire serial bus.

Dimensions

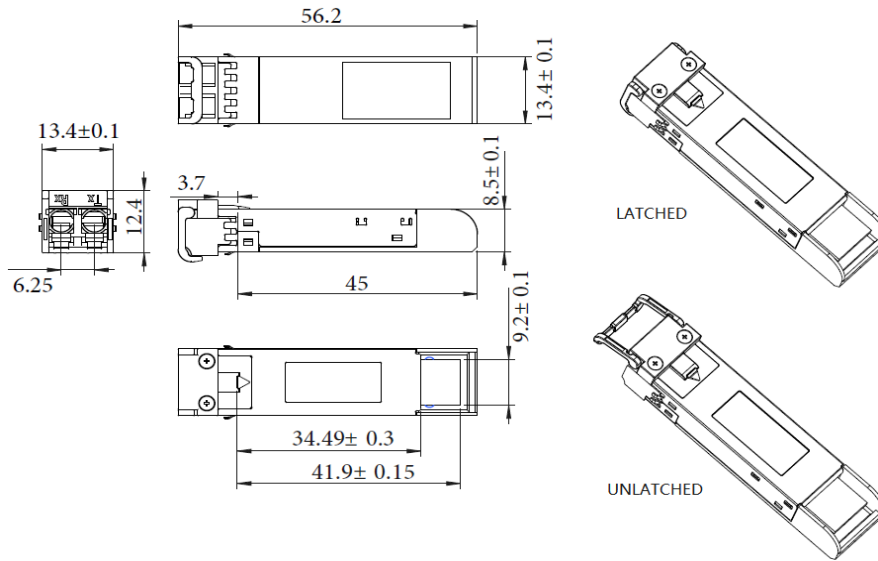

ALL DIMENSIONS ARE ±0.2mm UNLESS OTHERWISE SPECIFIED
UNIT: mm

Electrical Pad Layout

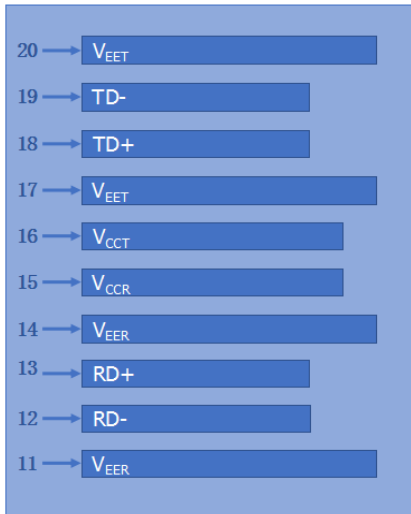

Top of Board

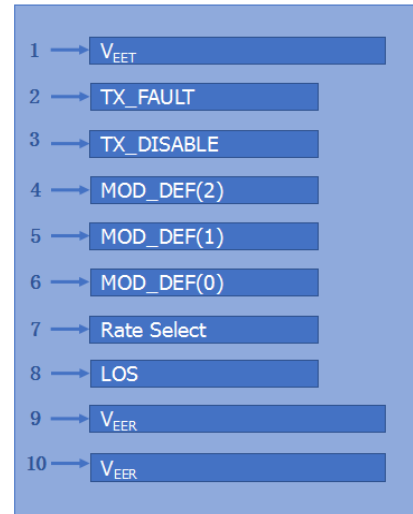

Bottom of Board

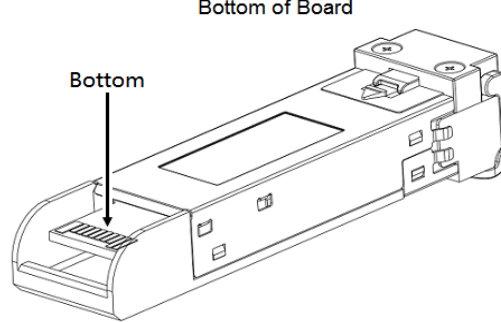
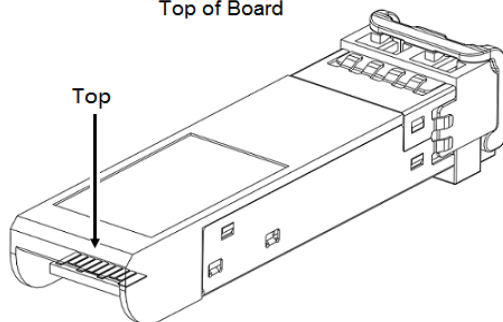

Pin Assignment

PIN #	Symbol	Description	Remarks
1	V _{EET}	Transmitter ground (common with receiver ground)	1
2	TX_FAULT	Transmitter Fault. Not supported	
3	TX_DISABLE	Transmitter Disable. Laser output disabled on high or open	2
4	MOD_DEF(2)	Module Definition 2. Data line for serial ID	3
5	MOD_DEF(1)	Module Definition 1. Clock line for serial ID	3
6	MOD_DEF(0)	Module Definition 0. Grounded within the module	3
7	Rate Select	No connection required	
8	LOS	Loss of Signal indication. Logic 0 indicates normal operation	4
9	V _{EER}	Receiver ground (common with transmitter ground)	1
10	V _{EER}	Receiver ground (common with transmitter ground)	1
11	V _{EER}	Receiver ground (common with transmitter ground)	1
12	RD-	Receiver Inverted DATA out. AC coupled	
13	RD+	Receiver Non-inverted DATA out. AC coupled	
14	V _{EER}	Receiver ground (common with transmitter ground)	1
15	V _{CCR}	Receiver power supply	
16	V _{CCT}	Transmitter power supply	
17	V _{EET}	Transmitter ground (common with receiver ground)	1
18	TD+	Transmitter Non-Inverted DATA in. AC coupled	
19	TD-	Transmitter Inverted DATA in. AC coupled	
20	V _{EET}	Transmitter ground (common with receiver ground)	1

Notes:

1. Circuit ground is isolated from chassis ground
2. Disabled: T_{DIS} > 2V or open, Enabled: T_{DIS} < 0.8V
3. Should Be pulled up with 4.7k - 10k ohm on host board to a voltage between 2V and 3.6V
4. LOS is open collector output

References

1. IEEE standard 802.3. IEEE Standard Department, 2002.
2. [Small Form Factor Pluggable \(SFP\) Transceiver Multi-Source Agreement \(MSA\), INF-8074i.](#)
3. Fiber Channel Draft Physical Interface Specification (FC-PI-2 Rev.5).
4. [Digital Diagnostics Monitoring Interface for Optical Transceivers -SFF-8472.](#)
5. Fiber Channel Physical and Signaling Interface (FC-PH/PH2/PH3).