

622Mb/s SFP 15km Optical Transceiver

Product Features

- Transmission data rate up to 622Mbit/s
- Up to 15km on 9/125 μ m SMF
- 1310nm FP laser transmitter
- 3.3V power supply voltage
- Hot Pluggable SFP form factor
- Duplex LC connector
- Compliant with SFF-8472
- Built-in digital diagnostic function
- RoHS compliant and Lead Free

Applications

- SONET OC-12 IR-1/SDH STM S-4.1

The AC-F-SFPO12-IR1-xx is a high performance, cost effective module which has a Duplex LC connector interface. Standard AC coupled CML for high speed signal and LVTTTL control and monitor signals. The receiver section uses a PIN receiver and the transmitter uses 1310nm FP laser, supporting 622Mbps 15km application.

Ordering Information

Part Number	Description
AC-F-SFPO12-IR1-xx	SFP 622Mbps 1310nm 15km optical transceiver

Regulatory Compliance

Feature	Standard	Performance
Electromagnetic Interference (EMI)	FCC Part 15 Class B EN 55022:2010, Class B	Compatible with standards
Electromagnetic susceptibility (EMS)	EN 55024:2010	Compatible with standards
Laser Eye Safety	FDA 21CFR 1040.10 and 1040.11 EN60950, EN (IEC) 60825-1,2	Compatible with Class I laser product

Absolute Maximum Ratings

The operation in excess of any absolute maximum ratings might cause permanent damage to this module.

Parameter	Symbol	Min	Max	Unit	Notes
Storage Temperature	TS	-40	85	°C	
Operating Case Temperature	TOP	0	70	°C	
Power Supply Voltage	V _{CC}	-0.3	3.6	V	
Relative Humidity (non-condensation)	RH	0	85	%	
Input Voltage	V _{in}	-0.3	V _{CC} +0.3	V	

Recommended Operating Conditions and Power Supply Requirements

Parameter	Symbol	Min	Typical	Max	Unit	Notes
Operating Case Temperature	TOP	0		70	°C	
Power Supply Voltage	V _{CC}	3.135	3.3	3.465	V	
Power Consumption				1	W	
Data Rate	DR		622		Mbps	
Link Distance with MMF	D			15	km	

Electrical Characteristics

The following electrical characteristics are defined over the Recommended Operating Environment unless otherwise specified.

Parameter	Test Point	Min	Typical	Max	Unit	Notes
Differential input impedance	Z _{in}	90	100	110	ohm	
Differential Output impedance	Z _{out}	90	100	110	ohm	
Single ended input voltage amplitude	ΔV _{in}	200		1200	mVp-p	
Single ended output voltage amplitude	ΔV _{out}	250		1000	mVp-p	

Optical Characteristics

All parameters are specified under the recommended operating conditions unless otherwise specified..

Parameter	Symbol	Min	Typical	Max	Unit	Notes
Transmitter						
Center Wavelength	λ_C	1260	1310	1360	nm	1
RMS Spectral Width	λ_{rms}			3.5	nm	
Average Launch Power	PAVG	-9		-3	dBm	2
Rise/Fall Time	Tr/Tf			260	ps	3
Extinction Ratio	ER	9			dB	
Transmitter Eye Mask		Compliant with IEEE 802.3 standard				
Receiver						
Center Wavelength	λ_C	1260		1580	nm	
Damage Threshold	THd	-1			dBm	4,5
Receiver Sensitivity	SEN			-23	dBm	4,5
Signal Loss Assert Threshold	LOSA	-45			dBm	
Signal Loss Deassert Threshold	LOSD			-24	dBm	
LOS Hysteresis	LOSH	0.5			dB	

Notes:

1. Also specified to meet curves in FC-PI 13.0 Figures 18 and 19, which allow trade-off between wavelength spectral width.
2. Class 1 Laser Safety per FDA/CDRH and EN(IEC) 60825 regulations.
3. Unfiltered, 20-80%. Complies with IEEE 802.3(Gig.E), FC 1x and 2x eye masks when filtered.
4. Measured with conformance signals defined in FC-PI 13.0 specifications.
5. Measured with PRBS7 at 10^{-12} BER.
6. Dispersion limited per FC-PI Rev. 13.

Digital Diagnostic Functions

Digital diagnostics monitoring function is available on Axiom product. A 2-wire serial interface provides user to contact with module. It is compliant to SFF8472 Rev10.2 with internal calibration mode. For external calibration mode please contact our sales staff.

Parameter	Symbol	Min	Max	Unit	Notes
Temperature monitor absolute error	DMI_Temp	-3	+3	°C	
Supply voltage monitor absolute error	DMI_VCC	-0.1	+0.1	V	
TX power monitor absolute error	DMI_RX	-3	+3	dB	
RX power monitor absolute error	DMI_RX	-3	+3	dB	
Bias current monitor	DMI_Ibias	-10%	+10%	mA	

Recommended Circuit

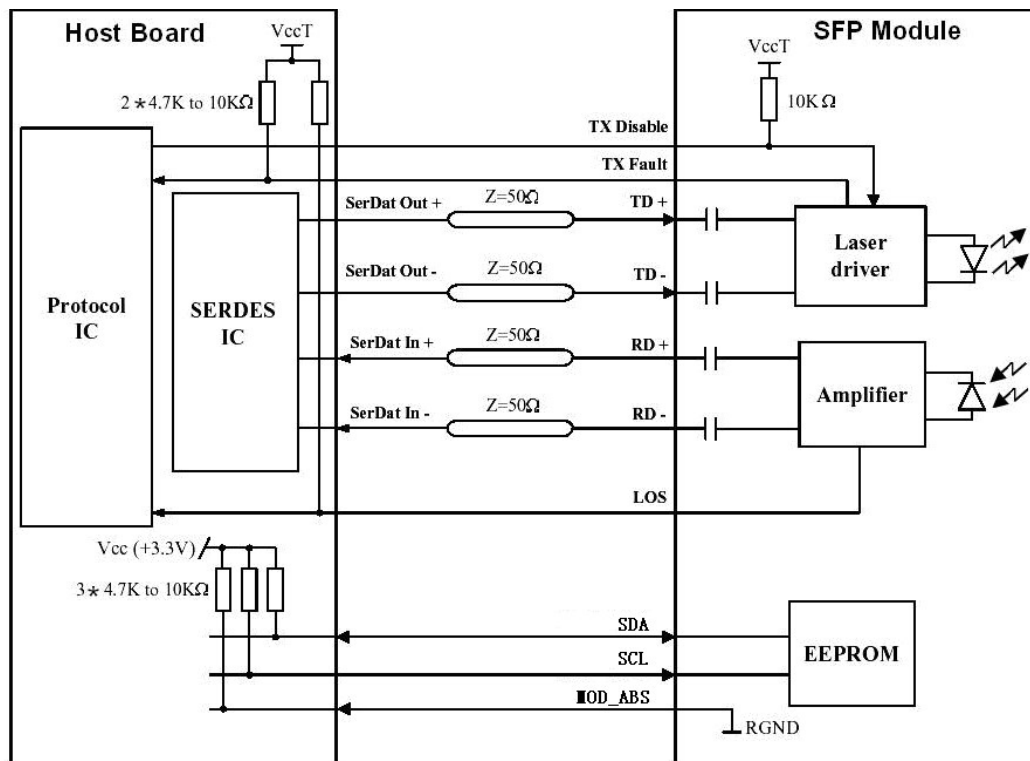

Mechanical Dimensions

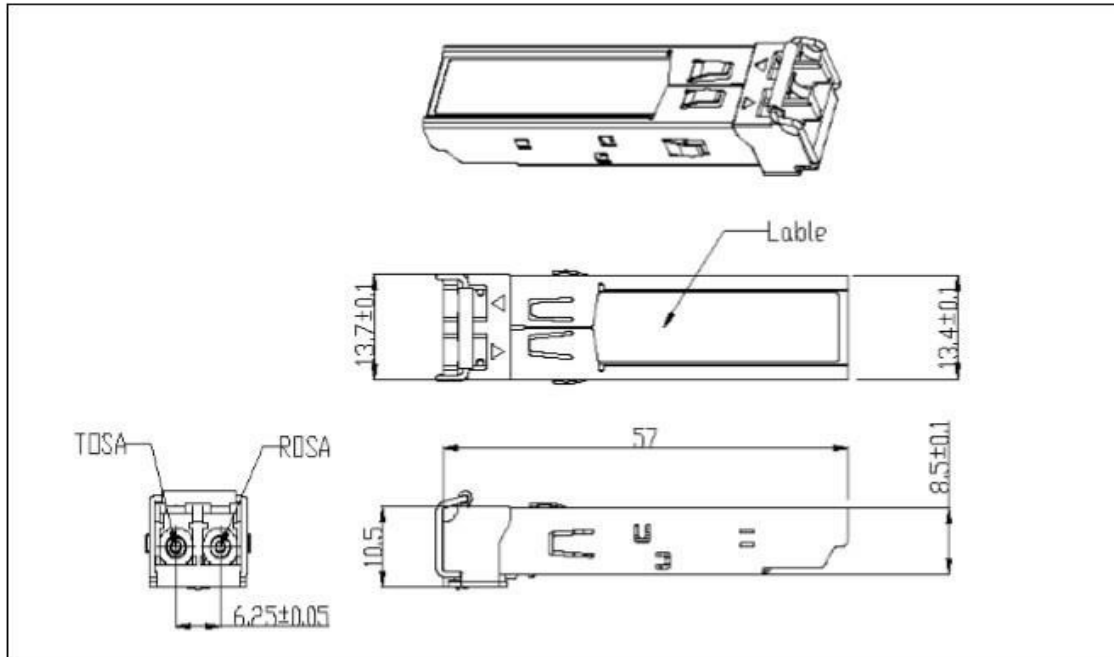

(Unit: mm [inch])

Pin Assignment and Description

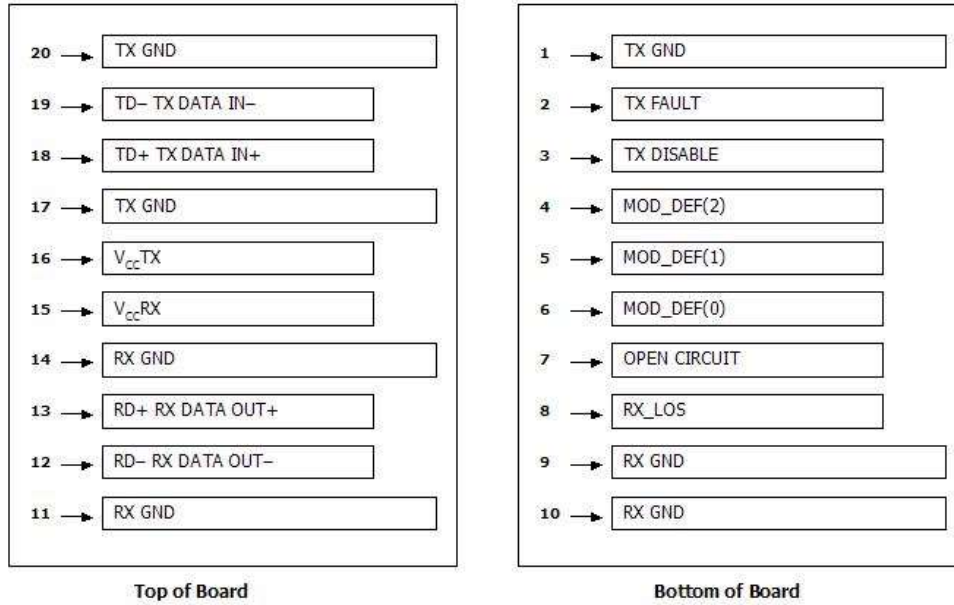

Pin Assignment

PIN #	Symbol	Description	Notes
1	VeeT	Transmitter Ground	1
2	TX Fault	Transmitter Fault Indication	
3	TX Disable	Transmitter Disable	2
4	MOD-DEF2	Module Definition	3
5	MOD-DEF1	Module Definition 1	3
6	MOD-DEF0	Module Definition 0	3
7	Rate Select	Not Connected	4
8	LOS	Loss of Signal	5
9	VeeR	Receiver Ground	1

10	VeeR	Receiver Ground	1
11	VeeR	Receiver Ground	1
12	RD-	Inv. Received Data Out	6
13	RD+	Received Data Out	6
14	VeeR	Receiver Ground	1
15	VccR	Receiver Power	1
16	VccT	Transmitter Power	
17	VeeT	Transmitter Ground	
18	TD+	Transmit Data In	6
19	TD-	Inv. Transmit In	6
20	VeeT	Transmitter Ground	

Notes:

1. Circuit ground is internally isolated from chassis ground.
2. Laser output disabled on TDIS >2.0V or open, enabled on TDIS <0.8V.
3. Should be pulled up with 4.7k - 10kohms on host board to a voltage between 2.0V and 3.6V. MOD_DEF(0) pulls line low to indicate module is plugged in.
4. Rate select is not used.
5. LOS is open collector output. Should be pulled up with 4.7k – 10kohms on host board to a voltage between 2.0V and 3.6V. Logic 0 indicates normal operation; logic 1 indicates loss of signal.
6. AC Coupled.