

The AX-I-XTUE-xx Small Form Factor 10Gb/s (XFP) transceiver is Axiom’s next generation T-XFP design which supports the E-temp operating range and it complies with the XFP Multi-Source Agreement (MSA) Specification1 while supporting advanced performance enhancements. It supports amplified DWDM 10Gb/s SONET/SDH, 10 Gigabit Ethernet, and 10 Gigabit Fibre Channel applications over 80km of fiber without dispersion compensation. Digital diagnostics functions are available via a 2-wire serial interface, as specified in the XFP MSA. The optical transceiver is compliant per the RoHS Directive 2011/65/EU3

PRODUCT FEATURES

- Supports 8.5Gb/s to 11.35Gb/s
- -300 to +1600 ps/nm Dispersion Tolerance
- Supports 50GHz ITU-based channel spacing (C-Band) with a wavelength locker
- Monolithic MZM Tunable TOSA
- Temperature range: -5°C to 85°C
- RoHS-6 Compliant (lead-free)
- Power dissipation <4.5W:
- Built-in digital diagnostic functions
- High performance APD Receiver
- Adjustable receiver threshold with option for automatic optimization through FEC feedback



APPLICATIONS

- DWDM 10Gb/s SONET/SDH
- DWDM 10Gb/s Ethernet & 10Gb/s Fibre Channel
- DWDM 10Gb/s SONET/SDH w/FEC
- DWDM 10Gb/s Ethernet and 10Gb/s Fibre Channel w/FEC

Part Number	Description
AC-I-XTUE-XX	10GBASE-DWDM TUNABLE XFP SMF, LC, 80KM, 15XXX.XXNM

I. Pin Descriptions

Pin	Logic	Symbol	Name/Description	Ref.
1		GND	Module Ground	1
2		VEE5	Optional -5.2 Power Supply – Not used	
3	LVTTL-I	Mod-Desel	Module De-select; When held low allows the module to respond to 2-wire serial interface commands	
4	LVTTL-O	Interrupt	Interrupt (bar); Indicates presence of an important condition which can be read over the serial 2-wire interface	2
5	LVTTL-I	TX_DIS	Transmitter Disable; Transmitter laser source turned off	
6		VCC5	+5 Power Supply	
7		GND	Module Ground	1
8		VCC3	+3.3V Power Supply	
9		VCC3	+3.3V Power Supply	
10	LVTTL-I	SCL	Serial 2-wire interface clock	2
11	LVTTL-I/O	SDA	Serial 2-wire interface data line	2
12	LVTTL-O	Mod_Abs	Module Absent; Indicates module is not present. Grounded in the module.	2
13	LVTTL-O	Mod_NR	Module Not Ready; Axiom defines it as a logical OR between RX_LOS and Loss of Lock in TX/RX.	2
14	LVTTL-O	RX_LOS	Receiver Loss of Signal indicator	2
15		GND	Module Ground	1
16		GND	Module Ground	1
17	CML-O	RD-	Receiver inverted data output	
18	CML-O	RD+	Receiver non-inverted data output	
19		GND	Module Ground	1
20		VCC2	+1.8V Power Supply – Not used	
21	LVTTL-I	P_Down/RST	Power Down; When high, places the module in the low power stand-by mode and on the falling edge of P_Down initiates a module reset Reset; The falling edge initiates a complete reset of the module including the 2-wire serial interface, equivalent to a power cycle.	
22		VCC2	+1.8V Power Supply – Not used	
23		GND	Module Ground	1
24	PECL-I	RefCLK+	Not Required	
25	PECL-I	RefCLK-	Not Required	
26		GND	Module Ground	1
27		GND	Module Ground	1
28	CML-I	TD-	Transmitter inverted data input	
29	CML-I	TD+	Transmitter non-inverted data input	
30		GND	Module Ground	1

Notes:

1. Module circuit ground is isolated from module chassis ground within the module.
2. Open collector; should be pulled up with 4.7k – 10kohms on host board to a voltage between 3.15V and 3.6V.

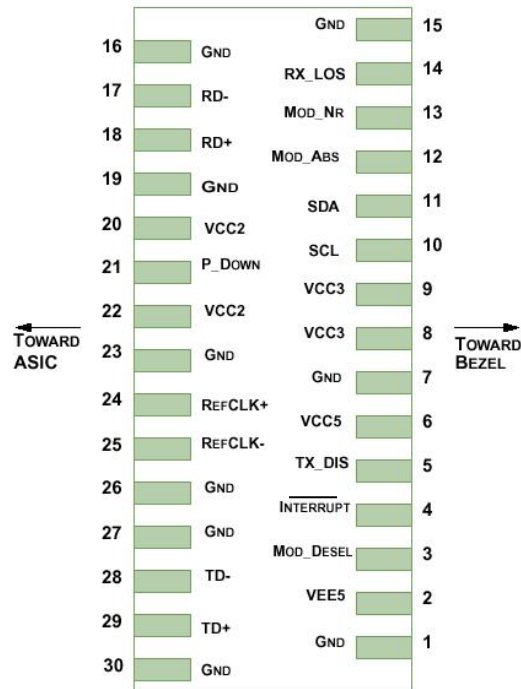

Diagram of Host Board Connector Block Pin Numbers and Names

II. Absolute Maximum Ratings

Parameter	Symbol	Min	Max	Unit	Ref.
Maximum Supply Voltage #1	Vcc3	-0.5	4.0	V	
Maximum Supply Voltage #2	Vcc2	-0.5	6.0	V	
Storage Temperature	T _S	-40	85	°C	
Case Operating Temperature	T _{OP}	-5	+85	°C	
Receiver Damage Threshold (Steady-state as well as transient)	P _{Rdmg}	+3		dBm	

III. Electrical Characteristics (EOL, Over Temperature and Wavelength Range)

AC-I-XTUE-xx							
Parameter	Symbol	Min	Typ	Max	Unit	Ref.	
Supply Voltage #1	V _{cc3}	3.13		3.46	V		
Supply Voltage #2	V _{cc5}	4.75		5.25	V		
Supply Current – V _{cc5} supply	I _{cc5}			650	mA		
Supply Current – V _{cc3} supply	I _{cc3}			750	mA		
Module total power dissipation	P			4.5	W		
Transmitter							
Input differential impedance	R _{in}		100		Ω	2	
Differential data input swing	V _{in,pp}	120		820	mV		
Transmit Disable Voltage	V _D	2.0		V _{cc}	V	3	
Transmit Enable Voltage	V _{EN}	GND		GND+ 0.8	V		
Receiver							
Differential data output swing	V _{out,pp}		500	850	mV	4	
Data output rise time	t _r			40	ps	5	
Data output fall time	t _f			40	ps	5	
LOS Fault	V _{LOS fault}	V _{cc} – 0.5		V _{ccHOST}	V	6	
LOS Normal	V _{LOS norm}	GND		GND+0.5	V	6	
Power Supply Rejection	PSR	See Note 7 below					7
Reference Clock (AC-Coupled)							
Single-ended peak to peak voltage swing	V _{SEPP}	200		900	mV		
Single-ended resistance	R _L	40	50	60			
Frequency clock tolerance	Δf	-100		+100	ppm		
Duty cycle	-	40		60	%		

Notes:

- Maximum total power value is specified across the full temperature and voltage range.
- After internal AC coupling.
- Or open circuit.
- Into 100 ohms differential termination.
- 20 – 80 %
- Loss Of Signal is open collector to be pulled up with a 4.7k – 10kohm resistor to 3.15 – 3.6V. Logic 0 indicates normal operation; logic 1 indicates no signal detected.
- Per Section 2.7.1. in the XFP MSA Specification¹.

IV. Optical Characteristics (EOL, Over Temperature and Wavelength Range)

AC-I-XTUE-xx						
Transmitter						
Parameter	Symbol	Min	Typ	Max	Unit	Ref
Output Opt. Pwr: 9/125 SMF	P_{OUT}	-1		+3	dBm	
Output Opt. Pwr during tuning	P_{TUNE}			-35	dBm	
Optical Extinction Ratio	ER	9			dB	
Wavelength range (ITU Grid)	Λ	1528.77		1563.86	nm	191.70THz to 196.10THz (89 channels)
Crossing Ratio		40		60	%	
Center Wavelength Spacing			50		GHz	1
Transmitter Center Wavelength – End Of Life	λ_c	$\lambda_c - 2.5$	λ_c	$\lambda_c + 2.5$	GHz	2
Side Mode Suppression Ratio	SMSR	35			dB	
Wavelength tuning (Cold Start)				30	s	
Wavelength tuning (Warm)			0.5	2	s	
Tx Jitter (SONET) 20kHz-80MHz	T_{xj1}			0.3	UI	3
Tx Jitter (SONET) 4MHz – 80MHz	T_{xj2}			0.1	UI	4
Relative Intensity Noise	RIN			-135	dB/Hz	
SBS threshold (1% of launch power reflected) – with Dither On		+16			dBm	Default is Dither OFF
Receiver						
Overload	P_{MAX}	-6			dBm	
Optical Center Wavelength	λ_C	1270		1615	nm	
Receiver Reflectance	R_{RX}			-27	dB	
LOS De-Assert	LOS_D			-30	dBm	
LOS Assert	LOS_A	-37			dBm	
LOS Hysteresis		0.5			dB	

AC-I-XTUE-xx					
Receiver Sensitivity ⁵					
Data rate (Gb/s)	BER	Dispersion (ps/nm)	Sensitivity through Fiber at OSNR >30dB (dBm)		Threshold Adjust Required
10.7	1E-4	-300 to 1600	-25.5		Yes
Data rate (Gb/s)	BER	Dispersion (ps/nm)	Sensitivity back-to-back at OSNR>30dB (dBm)	Dispersion Penalty at OSNR>30dB (dB)	Threshold Adjust Required
9.95	1e-12	-300 to 1450	-24	2	No
10.3	1e-12	-300 to 1450	-24	2	No
10.7	1e-4	-300 to 1450	-28	2.5	Yes
11.1	1e-4	-300 to 1450	-28	3	Yes
11.3	1e-4	-300 to 1450	-27	3	Yes
OSNR Performance ⁶					
Data rate (Gb/s)	BER	Dispersion (ps/nm)	Min OSNR Back-to-back at Power: -18 to -7dBm (dB)	Max OSNR Penalty at Power: -18 to -7dBm (dB)	Threshold Adjust Required
9.95	1e-12	-300 to 1450	22	3	Yes
10.3	1e-12	-300 to 1450	22	3	Yes
10.7	1e-4	-300 to 1450	14.5	3	Yes
11.1	1e-4	-300 to 1450	14.5	3	Yes
11.3	1e-4	-300 to 1450	15	3	Yes

Notes:

1. Corresponds to approximately 0.4 nm.
2. λ_c = Specified ITU Grid wavelength. Wavelength stability is achieved within 30 seconds of power up.
3. Measured with a host jitter of 50 mUI peak-to-peak.
4. Measured with a host jitter of 7 mUI RMS.
5. Measured at 1528-1600nm with worst ER; PRBS31.
6. All OSNR measurements are performed with 0.1nm resolution.

V. Additional Specifications and Response Timing

Parameter	Symbol	Min	Typ	Max	Units	Ref.
Bit Rate	BR	8.5		11.35	Gb/s	1
Maximum Supported Link Length	L _{MAX}		80		km	2
PMD Penalty (30ps of DGD)				1	dB	

Notes:

1. Amplified SONET OC-192, 10G Ethernet, SONET OC-192 with FEC, 10G Ethernet with FEC, 10G Fibre Channel with FEC.
2. Distance indicates dispersion budget. Optical amplification may be required to achieve maximum distance.

Transmitter Power Monitor Accuracy

Initial accuracy at 25C: +/- 1.5dB.

Relative accuracy over temperature, voltage and aging: +/- 2dB.

Received Optical Power Monitor Accuracy (applicable measurement range defined from -24dBm to -6dBm)

Initial accuracy at 25C: +/- 1.5dB.

Relative accuracy over temperature, voltage and aging: +/- 2dB.

Response timing:

Parameter		Min	Typ	Max	Units	Ref.
Tx_Dis	Assert			10	us	
	De-assert			2	ms	
Rx_LOS	Asset			100	us	
	De-assert			100	us	
Mod_NR	Asset			1	ms	
	De-assert			1	ms	
Interrupt	Asset			200	ms	
	De-assert			500	us	
P_Down/RST Time		10			us	
P_Down/RST Asser Delay				100	us	
Start-up time (Initialize time)				300	ms	1

1. Time required for transponder to be ready to begin I2C communication with host from a cold start or a hardware reset condition.

VI. Environmental Specifications

Axiom AC-I-XTUE-xx transceivers have an operating temperature from -5°C to +85°C case temperature.

Parameter	Symbol	Min	Max	Units	Ref.
Case Operating Temperature	T _{op}	-5	85	°C	
Storage Temperature	T _{sto}	-40	85	°C	

VII. Regulatory Compliance

Axiom Tunable XFP transceivers are Class 1 Laser Products and are certified per the following standards:

Feature	Agency	Standard	Certificate Number
Laser Eye Safety	FDA/CDRH	CDRH 21 CFR 1040 and Laser Notice 50	Available upon request
Laser Eye Safety	TÜV	EN 60825-1: 1994+A11:1996+A2:2001 IEC 60825-1: 1993+A1:1997+A2:2001 IEC 60825-2: 2000, Edition 2	Available upon request
Electrical Safety	TÜV	EN 60950	Available upon request
Electrical Safety	UL/CSA	CLASS 3862.07 CLASS 3862.87	Available upon request

VIII. Digital Diagnostics Functions

As defined by the XFP MSA¹, Axiom XFP transceivers provide digital diagnostic functions via a 2-wire serial interface, which allows real-time access to the following operating parameters:

- Transceiver temperature
- Laser bias current
- Transmitted optical power
- Received optical power
- Transceiver supply voltage
- TEC Temperature

It also provides a sophisticated system of alarm and warning flags, which may be used to alert end-users when particular operating parameters are outside of a factory-set normal range.

The operating and diagnostics information is monitored and reported by a Digital Diagnostics Transceiver Controller (DDTC) inside the transceiver, which is accessed through the 2-wire serial interface. When the serial protocol is activated, the serial clock signal (SCL pin) is generated by the host. The positive edge clocks data into the XFP transceiver into those segments of its memory map that are not write-protected. The negative edge clocks data from the XFP transceiver. The serial data signal (SDA pin) is bi-directional for serial data transfer. The host uses SDA in conjunction with SCL to mark the start and end of serial protocol activation. The memories are organized as a series of 8-bit data words that can be addressed individually or sequentially. The 2-wire serial interface provides sequential or random access to the 8 bit parameters, addressed from 000h to the maximum address of the memory.

For more detailed information, including memory map definitions, please see the XFP MSA documentation¹.

Receiver Threshold Adjustment

The AC-I-XTUE-xx modules also provide access to receiver decision threshold adjustment via 2-wire serial interface, in order to improve receiver OSNR performance based on specific link conditions. It is implemented as follows:

- Rx Threshold of XFP transceivers will be factory-set for optimized performance in non-FEC applications. This will be the default value during both cold start (power-up) and warm start (module reset).
- The transceiver supports adjustment of Rx Threshold value by the host through register 76d, table 01h. This is intended to be used in FEC applications.
- Register 76d, table 01h is a volatile memory. Therefore if the transceiver is power-cycled, the register starts up with a value of 00h which corresponds to the default Rx Threshold value.

- The threshold adjustment input value is 2’s complement 7 bit value (-128 to +127), with 0 corresponding to default Rx threshold value. Full range of adjustment provides at least a ±10% change in Rx threshold from the default value.
- An increase in RxDTV value sets the threshold closer to the “1” value of the eye. The Default setting is the factory tuned optimized set point and is not necessarily the 50% RxDTV value.

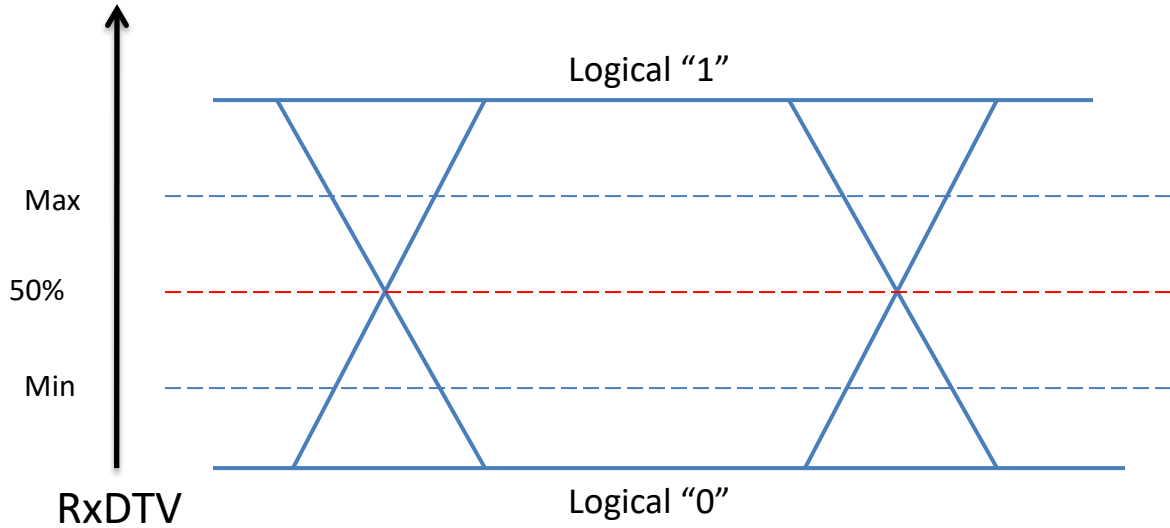

SBS suppression, dither tone

Set Address 111, bit 1 (Table A0h) to “0” to enable tone, “1” to disable dither tone (defaults: frequency = 40kHz , tone is disabled). Please contact your Axiom RSM or PLM if specific amplitudes and frequencies are needed for SBS suppression.

Tuning Management Interface for ITU Frequency Grid Applications

Implementation of wavelength or frequency tuning is indicated in Serial ID Byte 221 (Table 01h) bit 1.

Data Address	Bit	Description
221 (Table 01h)	1	Wavelength or frequency tunability implemented

The Axiom tunable XFP supports both wavelength and frequency tuning (as specified in INF-8077i), the wavelength tuning support is indicated by the transceiver description encoded in Serial ID Byte 138 bits 2 and 3.

Address	Bit	Description of transceiver
138	3	Tunable DWDM (selection by channel number, bytes 112-113)
138	2	Tunable DWDM (selection in 50 pm steps, bytes 72-73)
138	1-0	Reserved

Upon a power up, the module will go to a default wavelength (Axiom default channel is 1549.716nm) or the last channel set by the host. If Tx_DIS is asserted upon power up, the laser will be disabled and the set wavelength will be cleared. Once the Tx_DIS is de-asserted, the firmware will maintain the laser in an off state until the host sets the desired ITU channel. If the module is powered-down before the ITU channel was set and TX_DIS de-asserted, the module will re-start at the default channel. See the following startup channel flowchart.

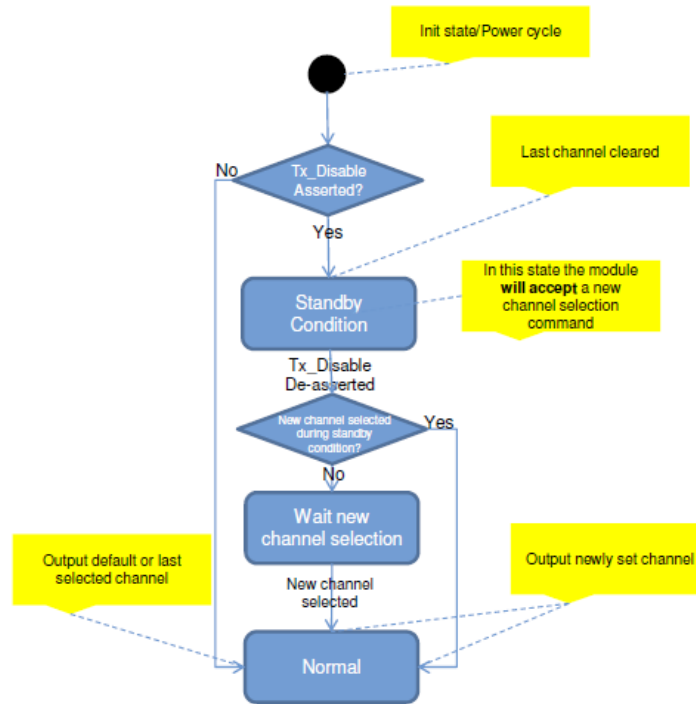

Flow Chart of Startup Channel

A desired wavelength can be commanded by the user by writing into Bytes 72 (MSB) and 73 (LSB). Wavelength control command:

Address	Bit	Name	Description
72 (MSB) & 73 (LSB)	All	Wavelength Set	User input of Wavelength set point (in units of 50 pm)
74 (MSB) & 75 (LSB)	All	Wavelength Error	Monitor of Current Wavelength Error (in units of 5 pm)

Thus for instance a target wavelength of 1556.55 nm would correspond to 79h (MSB) written to Byte address 72 and 9Bh (LSB) written to Byte address 73. Alternatively a desired frequency channel can be commanded by the user by writing into Bytes 112 (MSB) and 113 (LSB).

Address	Bit	Name	Description
112 (MSB) & 113 (LSB)	All	Channel Number Set	User input of channel number, which is an integer 1 to N (N=Number of Channels)
114 (MSB) & 115 (LSB)	All	Frequency Error	Frequency error reported in 16 bit signed integer with LSB=0.1 GHz
116-117	All	Reserved	Reserved

The channel number is derived from the following equation using parameters found in Module capabilities as listed in Byte Addresses 60-69:

Channel number = 1 + (Desired Frequency – First Frequency) / Grid Spacing

Alarm and Warning Threshold Values

Address	Parameter	Threshold Values	UNITS
02-03	Temp High Alarm	90	C
04-05	Temp Low Alarm	-13	C
06-07	Temp High Warning	88	C
08-09	Temp Low Warning	-8	C
10-17	Reserved		
18-19	Bias High Alarm	120	mA
20-21	Bias Low Alarm	5	mA
22-23	Bias High Warning	110	mA
24-25	Bias Low Warning	10	mA
26-27	TX Power High Alarm	+5	dBm
28-29	TX Power Low Alarm	-3	dBm
30-31	TX Power High Warning	+4	dBm
32-33	TX Power Low Warning	-2	dBm
34-35	RX Power High Alarm	-4	dBm
36-37	RX Power Low Alarm	-31	dBm
38-39	RX Power High Warning	-5	dBm
40-41	RX Power Low Warning	-25	dBm
42-43	AUX 1 High Alarm	57	C
44-45	AUX 1 Low Alarm	20	C
46-47	AUX 1 High Warning	54	C
48-49	AUX 1 Low Warning	25	C
50-51	AUX 2 High Alarm	3.564	V
52-53	AUX 2 Low Alarm	3.036	V
54-55	AUX 2 High Warning	3.465	V
56-57	AUX 2 Low Warning	3.135	V

A/D Table

Address	Parameter	Accuracy	Resolution	Units	Notes
96-97	Module Case Temp	+/-3	+/- 0.1	degC	PCB mounted thermocouple
98-99	Reserved				
100-101	TX bias current	+/-8	+/-2	uA	
102-103	Transmit Power	+/-1.5 dB	0.1	uW	
104-105	Receive Power	+/-1.5 dB	+/-0.1	uW	
106-107	Auxiliary monitor1	+/-3	+/-0.1	degC	Laser Temperature
108-109	Auxiliary monitor2	+/-3	+/-100	uV	3.3V Supply Voltage

IX. Mechanical Specifications

Axiom’s XFP transceivers are compliant with the dimensions defined by the XFP Multi-Sourcing Agreement (MSA).

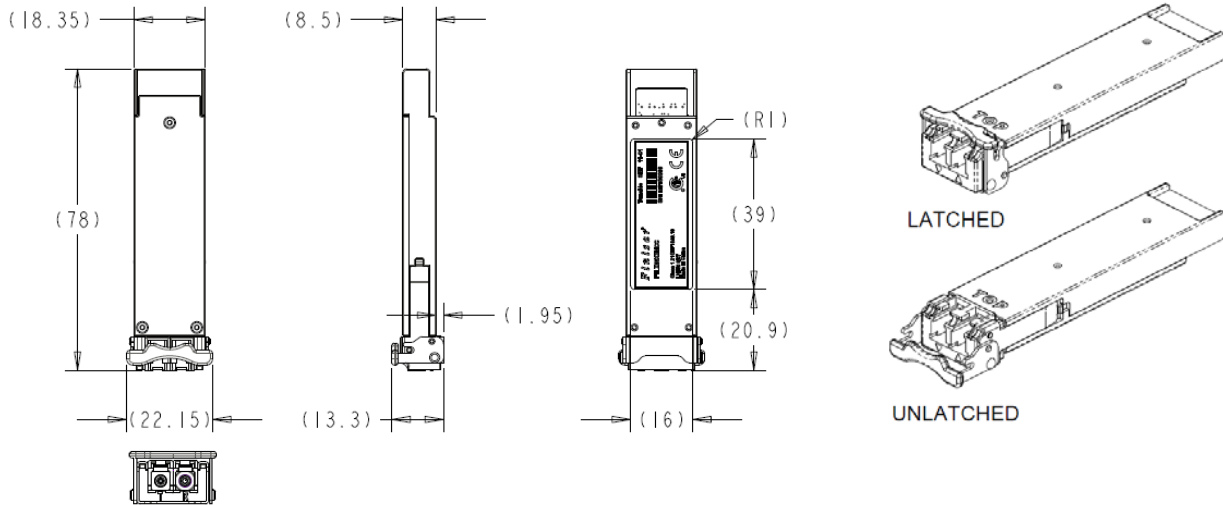

XFP Transceiver (dimensions are in mm)

X. PCB Layout and Bezel Recommendations

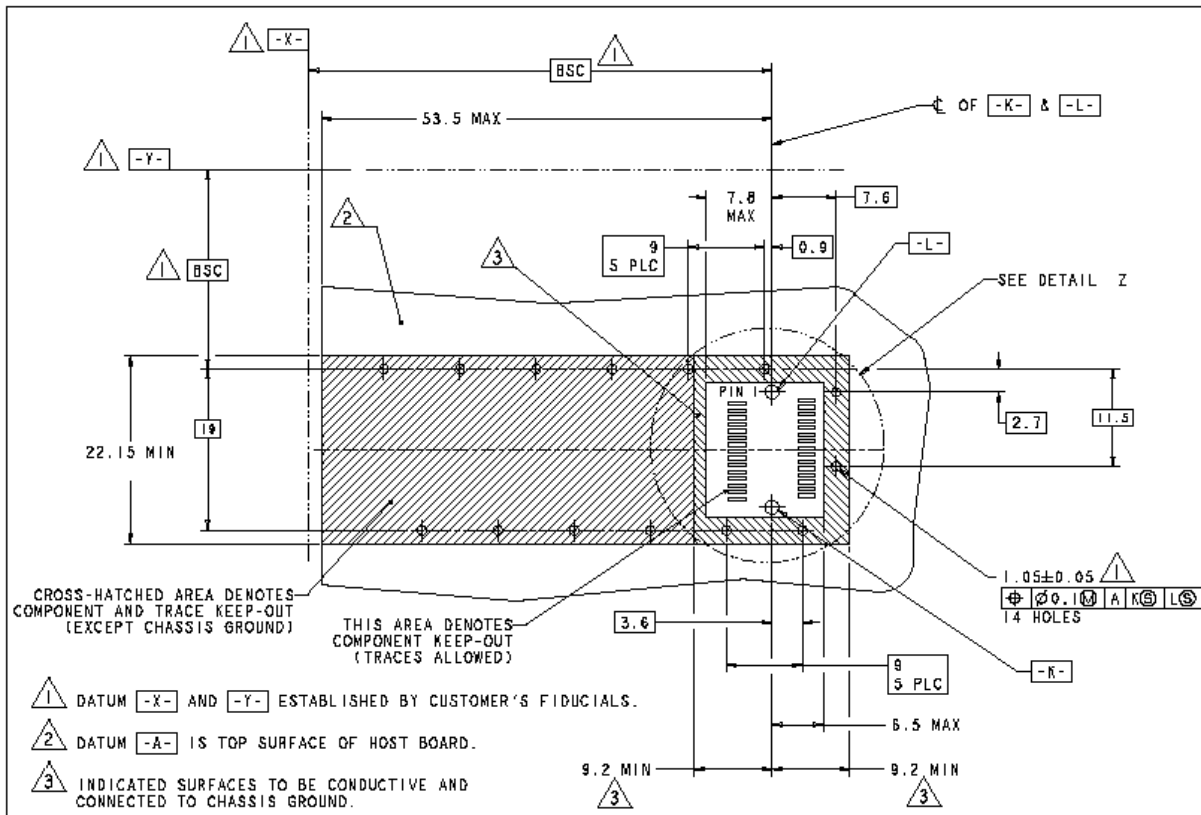

XFP Host Board Mechanical Layout (dimensions are in mm)

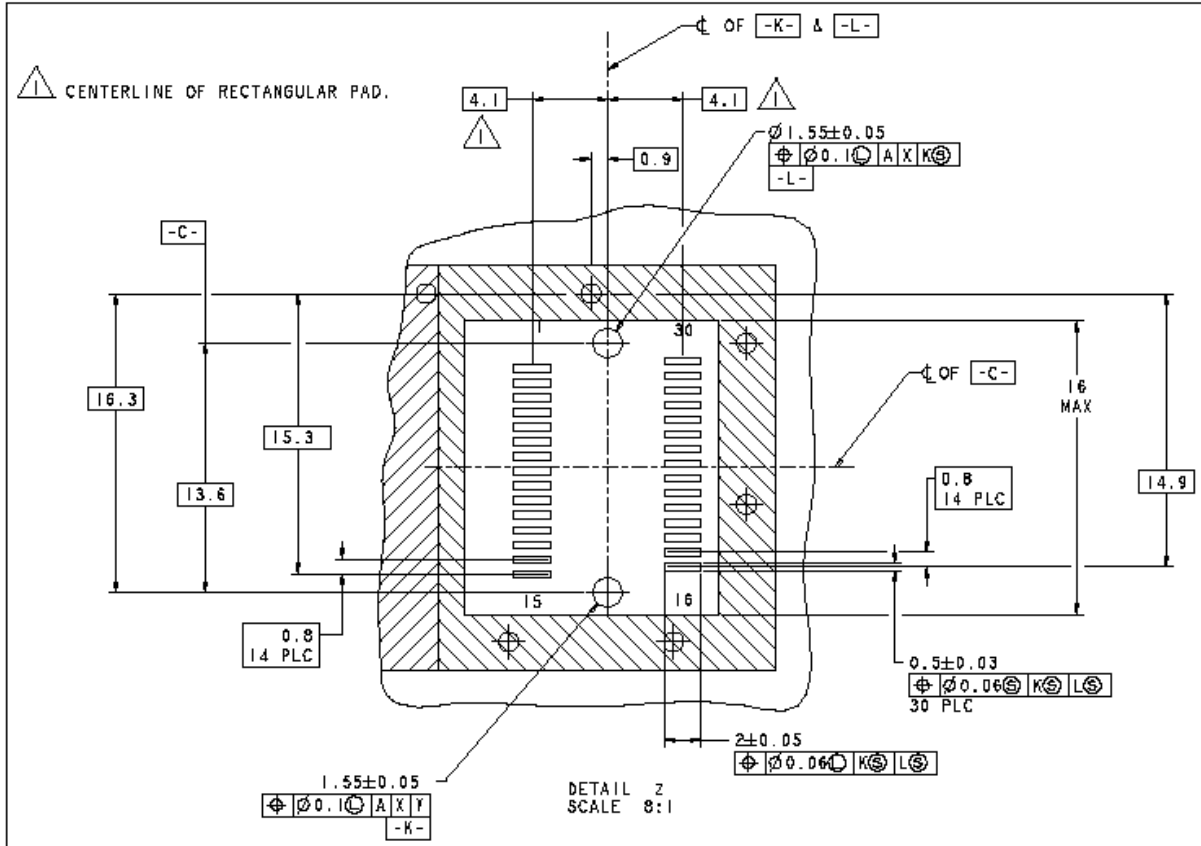

XFP Detail Host Board Mechanical Layout (dimensions are in mm)

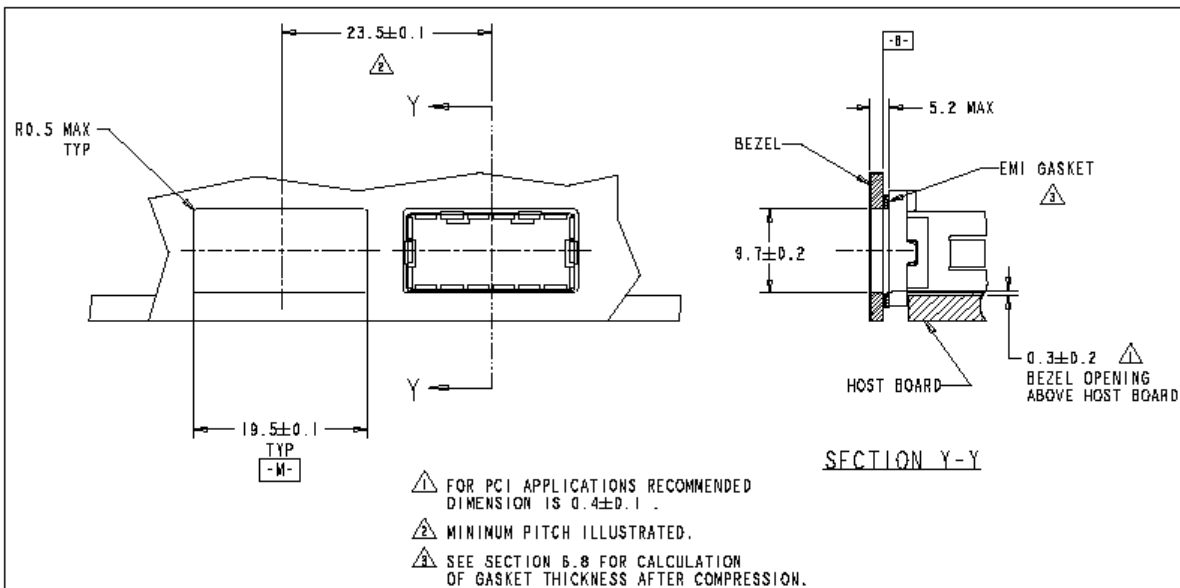

XFP Recommended Bezel Design (dimensions are in mm)

XI. Notes & Exceptions

- XFI and Line Loopback operation:
 - When XFI Loopback is enabled, the Transmitter output is disabled.
 - When Line Loopback is enabled, the CDR output is disabled.
- 8.5Gb/s operation requires configuration change via I2C vendor reserved command.

XII. References

1. 10 Gigabit Small Form Factor Pluggable Module (XFP) Multi-Source Agreement (MSA), Rev 4.5 – August 2005. Documentation is currently available at <http://www.xfpmsa.org/>
2. Directive 2011/65/EU of the European Council Parliament and of the Council, “on the restriction of the use of certain hazardous substances in electrical and electronic equipment”. Certain products may use one or more exemptions as allowed by the Directive.
3. SFF-8477 Revision 1.3: “Specification for Tunable XFP for ITU Frequency Grid Applications”. October 20th, 2008.