

100Gb/s QSFP28 SR4 Optical Transceiver

Product Features

- Four-channel full-duplex transceiver modules
- Transmission data rate 25.78Gbit/s per channel
- Up to 70m on OM3 Multimode Fiber (MMF) and 100m on OM4 MMF
- Low power consumption <2.5W
- Operating case temperature 0°C to +70°C
- 3.3V power supply voltage
- RoHS 6 compliant
- Hot Pluggable QSFP form factor
- MPO connector receptacle
- Built-in digital diagnostic function

Applications

- IEEE 802.3bm 100GBASE SR4
- Proprietary High Speed Interconnections
- Data center

The Axiom AC-V-Q28SR4-xx is a Four-Channel, Pluggable, Parallel, Fiber-Optic QSFP28 Transceiver for IEEE 802.3bm, 100GBASE SR4 Applications, or 40 Gigabit Ethernet and Infiniband FDR/EDR Applications.. The QSFP28 full-duplex optical module offers 4 independent transmit and receive channels, each capable of 25.78Gbps operation for an aggregate data rate of 100Gbps 70m using OM3 fiber and 100m on OM4. These modules are designed to operate over multimode fiber systems using 850nm VCSEL laser array. An optical fiber ribbon cable with an MPO/MTP connector can be plugged into the QSFP module receptacle. QSFP28 SR4 is one kind of parallel transceiver which provides increased port density and total system cost savings.

Ordering Information

Part Number	Description
AC-V-Q28SR4-xx	100G QSFP28 SR4, MPO connector, 100m on OM4

Regulatory Compliance

Feature	Standard	Performance
Electromagnetic Interference (EMI)	FCC Part 15 Class B EN 55022:2010, Class B	Compatible with standards
Electromagnetic susceptibility (EMS)	EN 55024:2010	Compatible with standards
Laser Eye Safety	FDA 21CFR 1040.10 and 1040.11 EN60950, EN (IEC) 60825-1,2	Compatible with Class I laser product

Absolute Maximum Ratings

The operation in excess of any absolute maximum ratings might cause permanent damage to this module.

Parameter	Symbol	Min	Max	Unit	Notes
Storage Temperature	TST	-40	85	degC	
Relative Humidity(non-condensing)	RH	0	85	%	
Operating Case Temperature	TOPC	0	70	degC	
Supply Voltage	VCC	-0.3	3.6	V	
Input Voltage	Vin	-0.3	Vcc+0.3	V	

Recommended Operating Conditions and Power Supply Requirements

Parameter	Symbol	Min	Typical	Max	Unit	Notes
Operating Case Temperature	TOPC	0		70	degC	Operating Case Temperature
Power Supply Voltage	VCC	3.13	3.3	3.47	V	Power Supply Voltage
Power Consumption				2.5	W	Power Consumption
Data Rate	DR		25.78125		Gbps	Data Rate
Data Speed Tolerance	Δ DR	-100		+100	ppm	Data Speed Tolerance
Link Distance with OM3 fiber	D	0		70	m	Link Distance with OM3 fiber

Electrical Characteristics

Parameter	Test Point	Min	Typical	Max	Unit	Notes
Differential input impedance	Zin	90	100	110	ohm	
Differential Output impedance	Zout	90	100	110	ohm	
Differential input voltage amplitude	Δ Vin	300		1100	mVp-p	
Differential output voltage amplitude	Δ Vout	500		800	mVp-p	
Bit Error Rate	BR			E-12		
Input Logic Level High	VIH	2.0		VCC	V	
Input Logic Level Low	VIL	0		0.8	V	
Output Logic Level High	VOH	VCC-0.5		VCC	V	
Output Logic Level Low	VOL	0		0.4	V	

Optical Characteristics

Parameter	Symbol	Min	Typical	Max	Unit	Notes
Transmitter						
Center Wavelength	λ_C	840	850	860	nm	1
RMS Spectral Width	λ_{rms}			0.65	nm	1
Average Launch Power, each lane	PAVG	-8.4		2.4	dBm	
Optical Modulation Amplitude (OMA)	POMA	-5		0	dBm	1
Difference in Launch Power between any two lanes	Ptx,diff			4.0	dB	
Launch Power in OMA minus Transmitter and Dispersion Penalty (TDP), each Lane	OMA-TDP			3.5	dB	1
Extinction Ratio	ER	3.5			dB	
Transmitter Eye Mask Margin	EMM	10			%	2
Average Launch Power OFF Transmitter, each Lane	Poff			-30	dBm	
Transmitter Eye Mask Definition {X1, X2, X3, Y1, Y2, Y3}		{ 0.3, 0.38, 0.45, 0.35, 0.41, 0.5 }				
Receiver						
Center Wavelength	λ_C	840	850	860	nm	
Damage Threshold	THd	3			dBm	
Overload, each lane	OVL	2.4			dBm	
Receiver Sensitivity in OMA, each Lane	SEN			-5.2	dBm	
Signal Loss Assert Threshold	LOSA	-30			dBm	
Signal Loss Deassert Threshold	LOSD			-9	dBm	
LOS Hysteresis	LOSH	0.5		6	dB	
Optical Return Loss	ORL			-12	dBm	

Notes:

1. Transmitter wavelength, RMS spectral width and power need to meet the OMA minus TDP specs to guarantee link performance.
2. The eye diagram is tested with 1000 waveform.

Digital Diagnostic Functions

The following digital diagnostic characteristics are defined over the normal operating conditions unless otherwise specified.

Parameter	Symbol	Min	Max	Unit	Notes
Temperature monitor absolute error	DMI_Temp	-3	3	degC	Over operating temp
Supply voltage monitor absolute error	DMI_VCC	-0.1	0.1	V	Full operating range
Channel RX power monitor absolute error	DMI_RX	-3	3	dB	Per channel
Channel Bias current monitor	DMI_Ibias	-10%	10%	mA	Per channel
Temperature monitor absolute error	DMI_Temp	-3	3	degC	Over operating temp

Power Supply Filtering

The host board should use the power supply filtering shown in Figure 1.

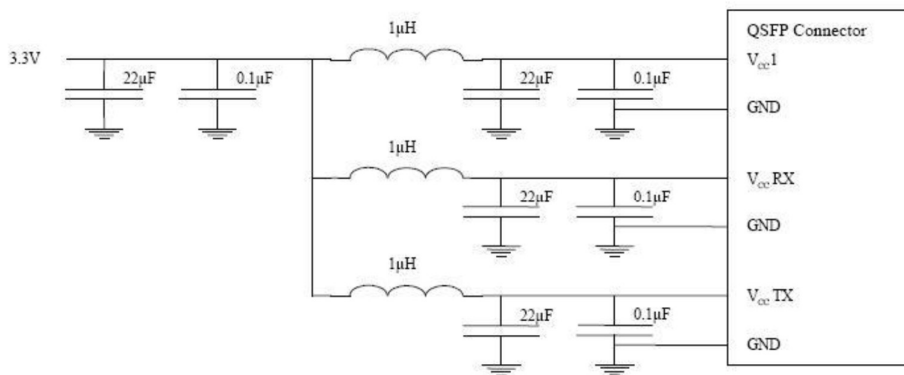

Figure1. Host Board Power Supply Filtering

Optical Interface Lanes and Assignment

The optical interface port is a male MPO connector. The four fiber positions on the left as shown in Figure 2, with the key up, are used for the optical transmit signals (Channel 1 through 4). The fiber positions on the right are used for the optical receive signals (Channel 4 through 1). The central four fibers are physically present.

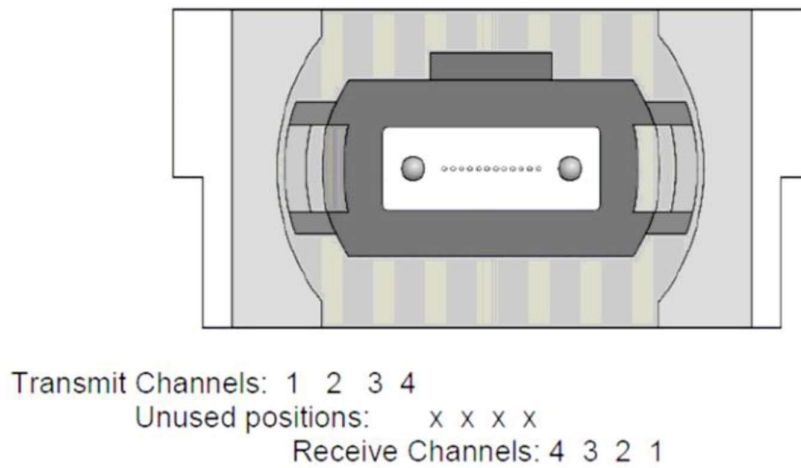
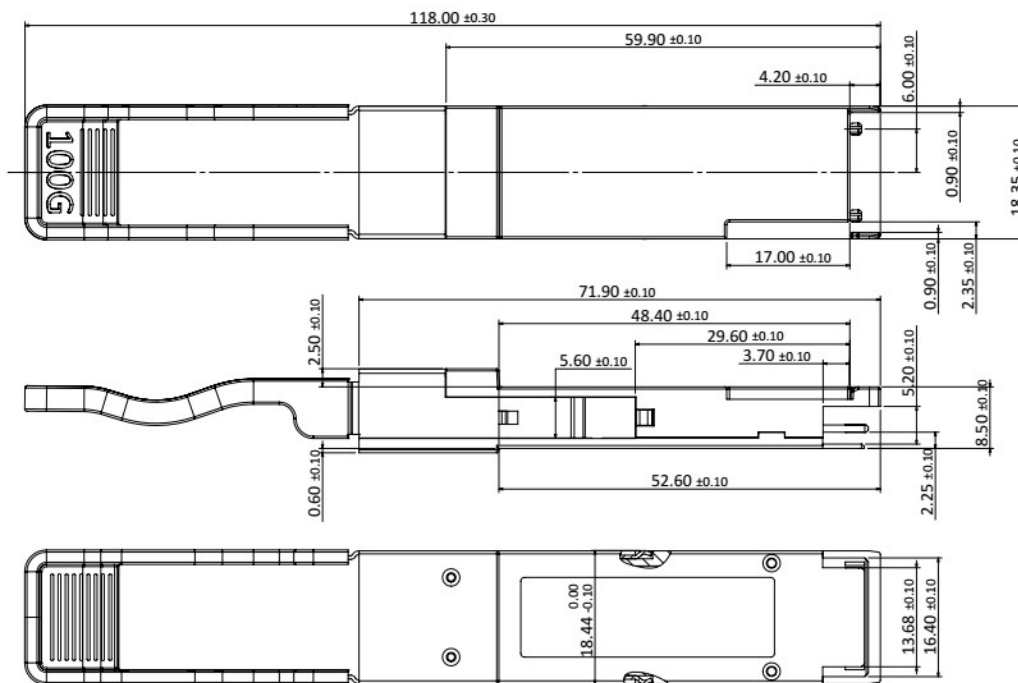

Figure 2. Optical Receptacle and Channel Orientation

Mechanical Dimensions



(Unit: mm [inch])

ESD

This transceiver is specified as ESD threshold 1kV for SFI pins and 2kV for all other electrical input pins, tested per MIL-STD-883, Method 3015.4 /JESD22-A114-A (HBM). However, normal ESD precautions are still required during the handling of this module. This transceiver is shipped in ESD protective packaging. It should be removed from the packaging and handled only in an ESD protected environment.

Laser Safety

This is a Class 1 Laser Product according to IEC 60825-1:2007. This product complies with 21 CFR 1040.10 and 1040.11 except for deviations pursuant to Laser Notice No. 50, dated (June 24, 2007).

Pin Assignment and Description

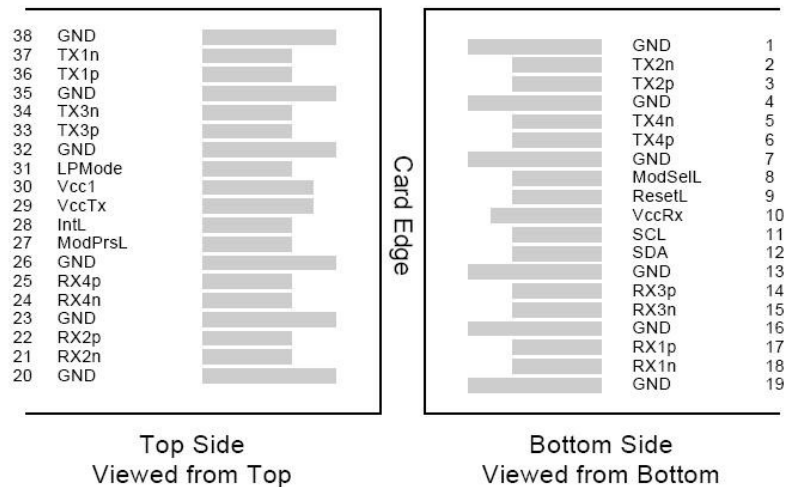

Pin Assignment

PIN #	Logic	Symbol	Description	Notes
1		GND	Ground	
2	CML-I	Tx2n	Transmitter Inverted Data Input	
3	CML-I	Tx2p	Transmitter Non-Inverted Data output	
4		GND	Ground	
5	CML-I	Tx4n	Transmitter Inverted Data Input	
6	CML-I	Tx4p	Transmitter Non-Inverted Data output	
7		GND	Ground	
8	LVTLL-I	ModSelL	Module Select	
9	LVTLL-I	ResetL	Module Reset	
10		VccRx	+3.3V Power Supply Receiver	
11	LVC MOS-I/O	SCL	2-Wire Serial Interface Clock	
12	LVC MOS-I/O	SDA	2-Wire Serial Interface Data	
13		GND	Ground	
14	CML-O	Rx3p	Receiver Non-Inverted Data Output	

15	CML-O	Rx3n	Receiver Inverted Data Output
16		GND	Ground
17	CML-O	Rx1p	Receiver Non-Inverted Data Output
18	CML-O	Rx1n	Receiver Inverted Data Output
19		GND	Ground
20		GND	Ground
21	CML-O	Rx2n	Receiver Inverted Data Output
22	CML-O	Rx2p	Receiver Non-Inverted Data Output
23		GND	Ground
24	CML-O	Rx4n	Receiver Inverted Data Output
25	CML-O	Rx4p	Receiver Non-Inverted Data Output
26		GND	Ground
27	LVTTL-O	ModPrsL	Module Present
28	LVTTL-O	IntL	Interrupt
29		VccTx	+3.3 V Power Supply transmitter
30		Vcc1	+3.3 V Power Supply
31	LVTTL-I	LPMODE	Low Power Mode
32		GND	Ground
33	CML-I	Tx3p	Transmitter Non-Inverted Data Input
34	CML-I	Tx3n	Transmitter Inverted Data Output
35		GND	Ground
36	CML-I	Tx1p	Transmitter Non-Inverted Data Input
37	CML-I	Tx1n	Transmitter Inverted Data Output
38		GND	Ground