

10Gb/s XFP SR 300m Optical Transceiver

Product Features

- 850nm Vcsel laser transmitter.
- Duplex LC connector
- 2-wire interface for management and diagnostic monitor
- XFI electrical interface with AC coupling
- Single power supply voltages : +3.3V
- Temperature range -5° C to 85° C
- Power dissipation: < 1.5W
- RoHS Compliant Part
- Support multi protocol from 9.95Gb/s to 11.3Gb/s
- Hot pluggable 30 pin connector
- Compliant with XFP MSA
- Transmission distance of 300m over multi mode fiber

This product is compliant with the current XFP Multi-Source Agreement (MSA) Specification. The high performance uncooled 850nm Vcsel transmitter and high sensitivity PIN receiver provide superior performance for 10G Fibre Channel and Ethernet applications up to 300m optical links.

Ordering Information

Part Number	Description
AC-V-XFPSR-E-xx	XFP 10G SR 300m MMF Extended Temperature optical transceiver

Regulatory Compliance

Feature	Standard	Performance
Electromagnetic Interference (EMI)	FCC Part 15 Class B	Compatible with standards
	EN 55022:2010, Class B	
Electromagnetic susceptibility (EMS)	EN 55024:2010	Compatible with standards
Laser Eye Safety	FDA 21CFR 1040.10 and 1040.11	Compatible with Class I laser product
	EN60950, EN (IEC) 60825-1,2	

Applications

- 10GBASE-SR/SW Ethernet
- 1200-Mx-SN-I 10G Fibre Channel
- SONET OC-192/SDH STM-64
- Other optical link

Absolute Maximum Ratings

The operation in excess of any absolute maximum ratings might cause permanent damage to this module.

Parameter	Symbol	Min	Max	Unit	Notes
Storage Temperature	TS	-40	85	degC	
Power Supply Voltage	VCC	-0.5	4.5	V	
Relative Humidity (non-condensation)	RH	5	85	%	

Recommended Operating Conditions and Power Supply Requirements

Parameter	Symbol	Min	Typical	Max	Unit	Notes
Operating Case Temperature	TOP	-5		85	degC	
Power Supply Voltage	VCC	3.135	3.3	3.465	V	
Power Supply Current	Icc			380	mA	

Optical Characteristics

Parameter	Symbol	Min	Typical	Max	Unit	Notes
Transmitter						
Operating Data Rate	BR	9.95		11.3	Gb/s	
Bit Error Rate	BER			10 ⁻¹²		
Launch Power	Pout	-6		-1	dBm	1
Optical Wavelength	λ	840	850	860	nm	
Optical Extinction Ratio	ER	3.5			dB	
RMS Spectral Width	λ_{RMS}			0.45	nm	
Sidemode Supression ratio	SSRmin	30			dB	
Rise/Fall Time (20%~80%)	Tr/Tf			35	ps	
Average Launch power of OFF Transmitter	POFF			-30	dBm	

Tx Jitter	Txj	Compliant with each standard requirements				
Optical Eye Mask		IEEE802.3ae				2
Receiver						
Operating Data Rate	BR	9.95		11.3	Gb/s	
Receiver Sensitivity	Sen			-11.1	dBm	2
Maximum Input Power	PMAX	0			dBm	2
Optical Center Wavelength	λ_C	780		860	nm	
Receiver Reflectance	Rrx			-12	dB	
LOS De-Assert	LOSD			-12	dBm	
LOS Assert	LOSA	-30			dBm	
LOS Hysteresis	LOSH	0.5		5	dB	

Notes:

1. The optical power is launched into MMF.
2. Measured with a PRBS $2^{31}-1$ test pattern @10.3125Gbps BER<10⁻¹².

Mechanical Dimension

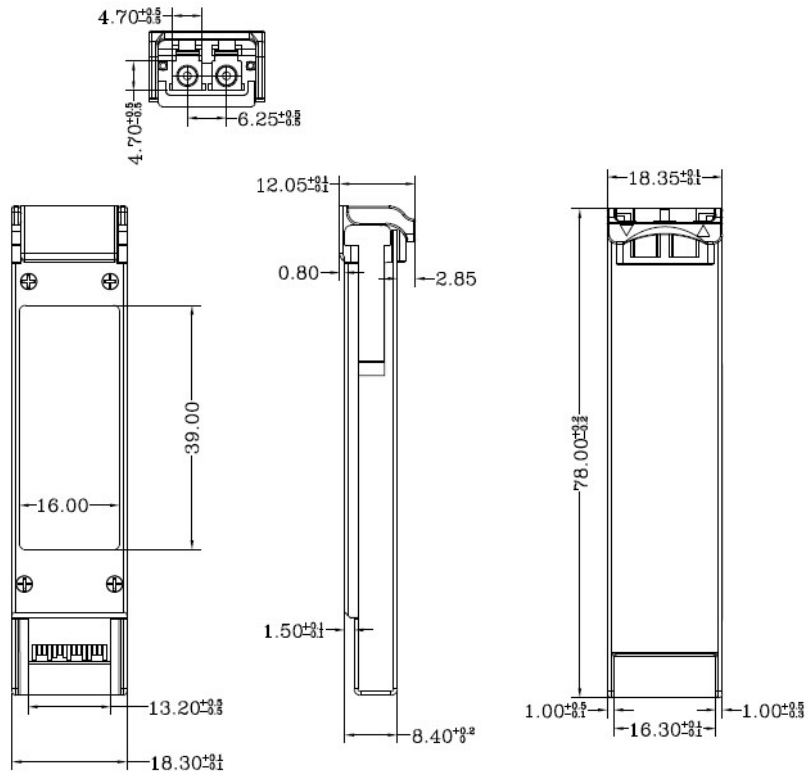

(Unit: mm [inch])

Recommended High-speed Interface Circuit

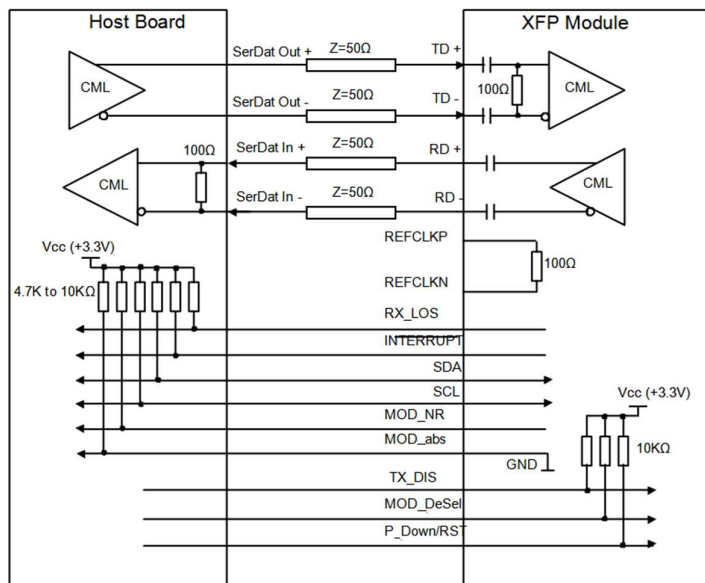

Pin Assignment and Description

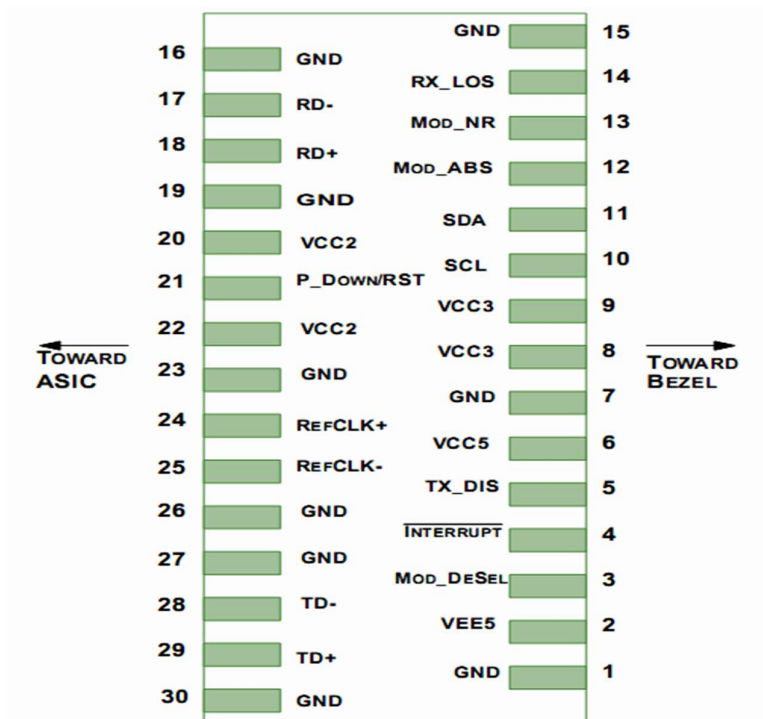

Pin Assignment

Pin	Logic	Symbol	Name/Description	Ref
1		GND	Module Ground	1
2		VEE5	Optional –5.2 Power Supply – Not required	
3	LVTTTL-I	Mod-Desel	Module De-select; When held low allows the module to, respond to 2-wire serial interface commands	
4	LVTTTL-O	Interrupt	Interrupt (bar); Indicates presence of an important condition which can be read over the serial 2-wire interface	2
5	LVTTTL-I	TX_DIS	Transmitter Disable; Transmitter laser source turned off	
6		VCC5	+5 Power Supply – Not required	
7		GND	Module Ground	1
8		VCC3	+3.3V Power Supply	
9		VCC3	+3.3V Power Supply	
10	LVTTTL-I	SCL	Serial 2-wire interface clock	2
11	LVTTTL-	SDA	Serial 2-wire interface data line	2
12	LVTTTL-O	Mod_Abs	Module Absent; Indicates module is not present. Grounded in the module.	2
13	LVTTTL-O	Mod_NR	Module Not Ready;	2
14	LVTTTL-O	RX_LOS	Receiver Loss of Signal indicator	2
15		GND	Module Ground	1
16		GND	Module Ground	1
17	CML-O	RD-	Receiver inverted data output	
18	CML-O	RD+	Receiver non-inverted data output	
19		GND	Module Ground	1
20		VCC2	+1.8V Power Supply – Not required	
21	LVTTTL-I	P_Down/RS T	Power Down; When high, places the module in the low power stand-by mode and on the falling edge of P_Down initiates a module reset	
			Reset; The falling edge initiates a complete reset of the module including the 2-wire serial interface, equivalent to a power cycle.	
22		VCC2	+1.8V Power Supply – Not required	
23		GND	Module Ground	1
24	PECL-I	RefCLK+	Reference Clock non-inverted input, AC coupled on the host board – Not required	3
25	PECL-I	RefCLK-	Reference Clock inverted input, AC coupled on the host board – Not required	3
26		GND	Module Ground	1
27		GND	Module Ground	1
28	CML-I	TD-	Transmitter inverted data input	
29	CML-I	TD+	Transmitter non-inverted data input	
30		GND	Module Ground	1

Notes:

1. Module circuit ground is isolated from module chassis ground within the module.
2. Open collector; should be pulled up with 4.7k – 10k ohms on host board to a voltage between 3.15V and 3.6V.
3. A Reference Clock input is not required .