

PRECISION Lead Screw Assemblies



Universal 
THREAD GRINDING COMPANY

Precision Lead Screw Assemblies

Universal Thread Grinding offers a comprehensive selection of standard precision lead screw assemblies. Installed with ordinary skills and equipment, *Universal* lead screw assemblies deliver their full rated accuracy. Applications include single or multi-axis positioning tables, instruments, or precision scanning mechanisms.

Universal's precision components are factory assembled, preloaded, and "run in" under ideal conditions. The patented self-aligning* and self-adjusting* nut and thrust bushing will accommodate and reduce the effects of misalignment and slide errors to bring out the best in stepping motor or servo systems.



ACCURACY:

Standard: 0.000050"/turn, 0.000100"/inch
Available: 0.000010"/turn, 0.000025"/inch

STOCK SIZES:

1/4" diameter, travel to 8"
1/2" diameter, travel to 20"

STANDARD LEADS:

Commonly used leads from 0.025" to 0.400", 1 mm to 5 mm.
Nonstandard leads quoted to your order.

*U.S. Patent Numbers: 3,977,269; 3,831,460; 4,434,677

We will be glad to help you specify the lowest cost unit that will meet your requirements.

About Universal

Universal Thread Grinding Company, located in Fairfield, CT, USA, offers high quality lead screw assemblies for precision, linear positioning applications.

Universal Thread was founded in 1946 to meet the needs of regional manufacturers by providing a wide range of customized thread grinding services. Development of expertise in manufacturing precision lead threads guided the evolution of our current product lines of precision lead screw and nut assemblies. For over 40 years the *Universal* lead screw assembly has been used worldwide, meeting the most demanding requirements.

Building the best lead screw assembly is Universal Thread's only mission. Whether you specify a standard product from our extensive stock, or require a customized product, you will get the full attention of our experienced staff.

Call us to discuss your specific requirements. Or visit our website, at www.universal-thread.com. Our e-mail response form will help you specify a customized lead screw assembly to meet your applications. Our Connecticut plant is fully stocked and ready to respond to your most immediate needs. We offer our years of experience, attention to detail, personal service and on time delivery.

VISIT OUR WEBSITE

www.universal-thread.com

Universal's website offers you up-to-date information including detailed product specifications and customized services.

In addition, our website includes:

- Application notes on banding
- A check off list to help you specify *Universal* Lead Screw Assemblies

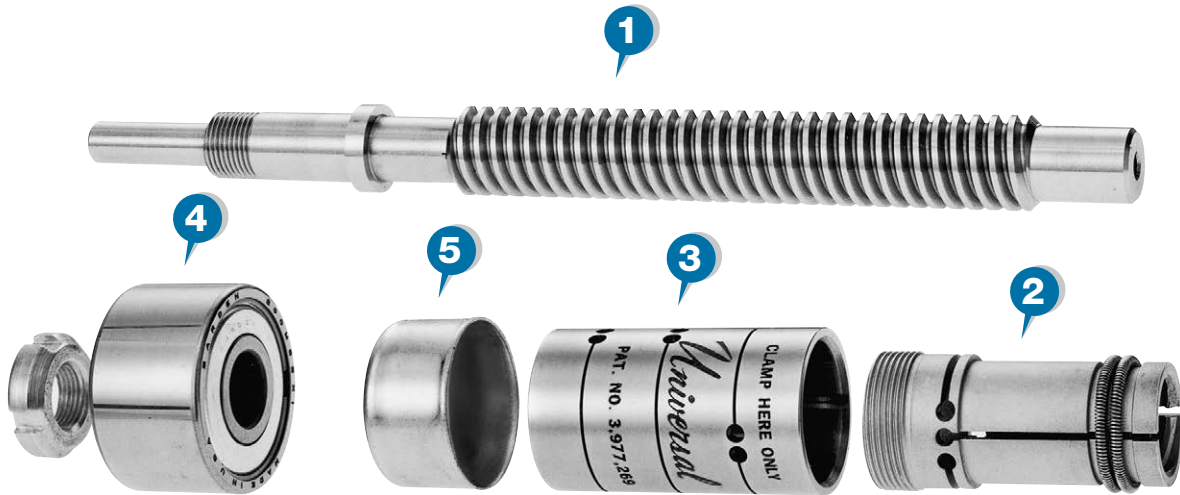

1 PRECISION LEAD SCREW

Manufactured of hardened, low temperature stabilized A6 tool steel, in four accuracy grades. Threads are ground and lapped. Thread to thread error as low as 0.000010" including drunkenness. Each screw is "run in" with its own nut.

2 PRELOADED NUT

One piece phosphor bronze split nut is self-adjusting. Radially preloaded nut halves respond to the average lead, further reducing residual one turn screw errors. Improved design achieves increased axial stiffness and suppresses backlash.

3 SELF-ALIGNING THRUST BUSHING

Multiflexured, one piece bushing transfers thrust from the nut to the external load in a theoretically ideal way. Reduces effects of residual eccentricity of lead screw and errors due to slide nonlinearity. Minimizes loading of air bearing slides.

4 THRUST BEARING

Precision preloaded double row ball thrust bearing, in a selection of axial thrust accuracies as good as 0.000010". Thrust bearing error adds directly to the lead screw drunkenness error. Lead screw performance is compromised unless a bearing with equally small errors is selected and properly

fitted. We select the best available, epoxy them in place, and retest after fitting. We can also advise you on practical techniques to achieve extreme thrust accuracies better than 0.000005".

5 OPTIONAL LUBRICATOR

The optional lubricator, factory installed on the nut, removes dust and lubricates the screw in applications where the screw is exposed and continuous lubrication cannot be provided. Periodic reoiling of the lubricator is required; we can supply the recommended oil.



All lead screws are shipped fully assembled and "run in" to intimately mate the screw and nut.

Specifications

Lead screw material – A6 hardened and low temperature stabilized.

Lead Screw Diameter	1/4"	1/2"
Maximum Available Travel	8"	20"
Standard Leads*	.025", .050", .100", .200", 1 mm, 2 mm	.025", .040", .050", .100", .125", .200", .400", 1 mm, 1.25 mm, 2 mm, 2.5 mm, 5 mm
Maximum No-Load Torque	4 oz in	8 oz in
Maximum Load (Including Inertial)	30 lb	50 lb
Working Load (Including Inertial)	8 lb	10 lb
Stiffness of Nut	4 lb / .0001"	5 lb / .0001"

*Other leads available by special quote.

Lead Accuracy

"X"	"XX"	"XXX"	"XXXX"
000050"/ turn	.000025"/ turn	.000010"/ turn	.000010"/ turn
.000100"/ inch	.000050"/ inch	.000025"/ inch	.000025"/ inch
.0004"/ foot	.0002"/ foot	.0002"/ foot	.0001"/ foot

Bearing Thrust Plane Accuracy

Standard – .000030"

Available – .000015", .000010"

INSTALLATION

SHAFT COUPLING

A flexible antibacklash coupling is needed between the drive motor and lead screw to isolate the motor bearing errors from the lead screw bearing. Metal bellows type couplings have been used successfully. Split clamps are recommended to prevent loosening by motor torque.

LUBRICATION

The lead nut requires proper lubrication for peak performance and longevity of the *Universal* lead screw assembly. Our B-3 lead screw oil provides the required boundary lubrication on the nut / screw interface, and offers excellent wear protection and uniform torque transition from static to dynamic conditions. The B-3 oil film must be periodically replenished, a procedure which may be accomplished by oil bath immersion, automatic application, or manual oiling on a maintenance schedule determined by the application parameters. Universal Thread's optional lubricator for the lead nut may be incorporated to extend the maintenance interval.

Universal Thread's own light grease, specified KS-46, provides exceptional performance in many applications. The KS-46's torque and wear characteristics are excellent, and required relubrication is less frequent than with oil.

Universal Thread has provided lubrication systems for special environments (e.g. vacuum, cryogenic, etc.). Please contact the factory with your special requirements.

MOUNTING

The lead screw must be rigidly mounted precisely parallel to the direction of motion. The O.D. of the thrust bearing must be a sliding fit in its bore, and must be clamped axially only.

When the travel is six inches or less the thrust bearing provides adequate radial support, and a bearing at the outboard end may be omitted.

When the travel exceeds six inches we recommend a radial bearing to support the outboard end. Free axial movement at this bearing must be permitted.

In every case the nut clamp area must be fully and rigidly supported by the other slide member. Coaxial alignment of the clamp area with the lead screw must be preserved within 0.002".

We will be glad to review your application and help you specify the lowest cost unit that will meet your requirements. We can advise you on special techniques to increase axial stiffness, and to achieve thrust plane accuracies better than 0.000005".

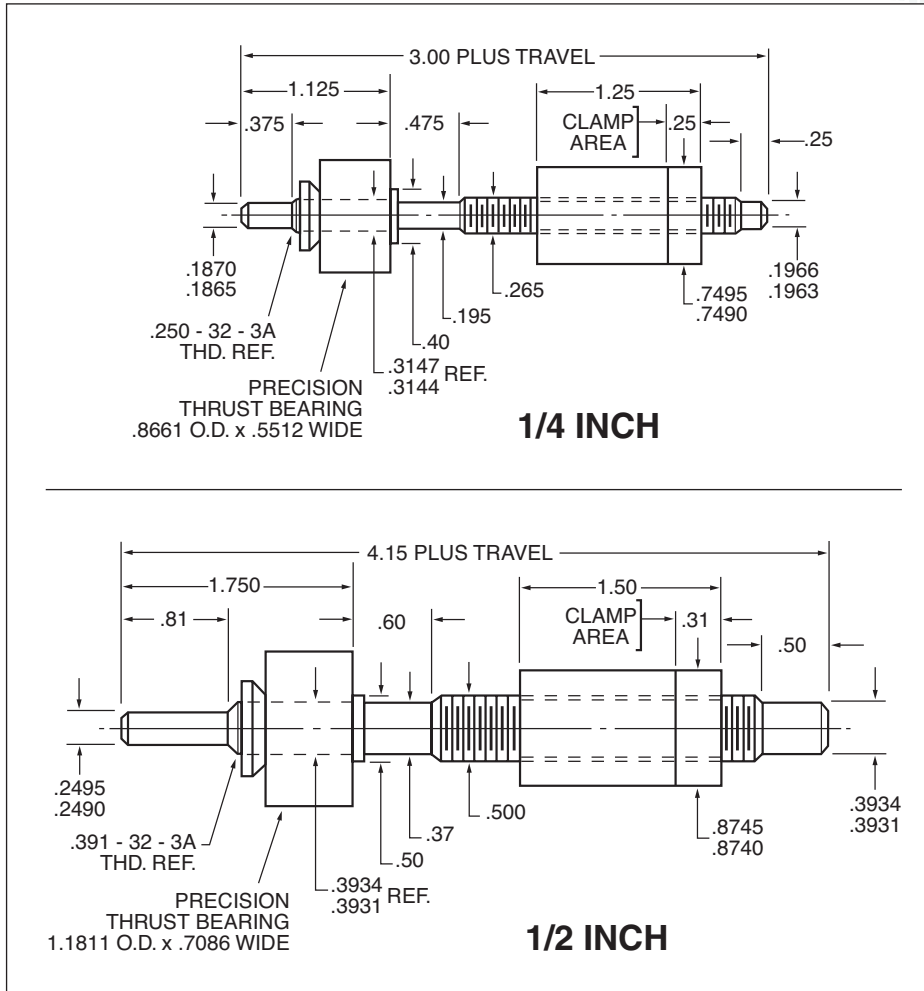

NOTES:

1. Nut can be factory assembled facing either direction, with clamp area closest to thrust bearing or away from thrust bearing. NUT ASSEMBLY MUST NOT BE REMOVED. Specify desired orientation when ordering.
2. Optional lubricator is installed on end of nut opposite clamp area. Must be factory installed when lubricator end of nut faces thrust bearing. Adds .38" to length of 1/4" nut and 1/2" nut, which may reduce travel and/or restrict installation options in some cases.

ORDERING AND CUSTOM CONFIGURATION – Please see the next page to specify *Universal Lead Screw Assemblies.*

Specify Lead Screw Assemblies

Check-off list to help you specify *Universal* Lead Screw Assemblies

See page 4 for specifications.

DIA.	<input type="checkbox"/> 1/4"	<input type="checkbox"/> 1/2"
LEAD	<input type="checkbox"/> .025" <input type="checkbox"/> 1 mm <input type="checkbox"/> .050" <input type="checkbox"/> 2 mm <input type="checkbox"/> .100" <input type="checkbox"/> .200"	<input type="checkbox"/> .025" <input type="checkbox"/> 1 mm <input type="checkbox"/> .040" <input type="checkbox"/> 1.25 mm <input type="checkbox"/> .050" <input type="checkbox"/> 2 mm <input type="checkbox"/> .100" <input type="checkbox"/> 2.5 mm <input type="checkbox"/> .125" <input type="checkbox"/> 5 mm <input type="checkbox"/> .200" <input type="checkbox"/> .400**
TRAVEL	<input type="checkbox"/> 1" <input type="checkbox"/> 2" <input type="checkbox"/> 4" <input type="checkbox"/> 6" <input type="checkbox"/> 8"	<input type="checkbox"/> 2" <input type="checkbox"/> 12" <input type="checkbox"/> 4" <input type="checkbox"/> 14" <input type="checkbox"/> 6" <input type="checkbox"/> 16" <input type="checkbox"/> 8" <input type="checkbox"/> 18" <input type="checkbox"/> 10" <input type="checkbox"/> 20"

*Restrictions may apply.

Lead Accuracy			
"X" <input type="checkbox"/>	"XX" <input type="checkbox"/>	"XXX" <input type="checkbox"/> *	"XXXX" <input type="checkbox"/> *
.000050"/ turn .000100"/ inch .0004"/ foot	.000025"/ turn .000050"/ inch .0002"/ foot	.000010"/ turn .000025"/ inch .0002"/ foot	.000010"/ turn .000025"/ inch .0001"/ foot

*Restrictions may apply.

Bearing Thrust Plane Accuracy

Standard: .000030"

Available: .000015" .000010"

Nut Orientation

- Clamp closest to thrust bearing
- Clamp away from thrust bearing

Lubrication

- B-3 Oil
- Brush Lubricator: yes no
- KS-46 Grease
- Special Conditions: Consult Factory

**For ordering assistance, call:
203-336-1849**

**For more information, visit:
www.universal-thread.com**

**Email us at:
catalogs@universal-thread.com**

Quality Assurance

Universal builds quality into Precision Lead Screw Assemblies

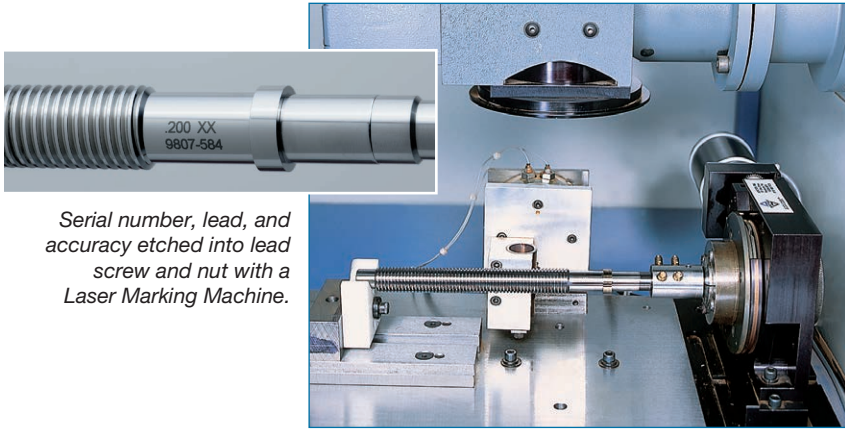

Serial number, lead, and accuracy etched into lead screw and nut with a Laser Marking Machine.



Cutting a pallet of thrust bushings using Electrical Discharge Machining (EDM).

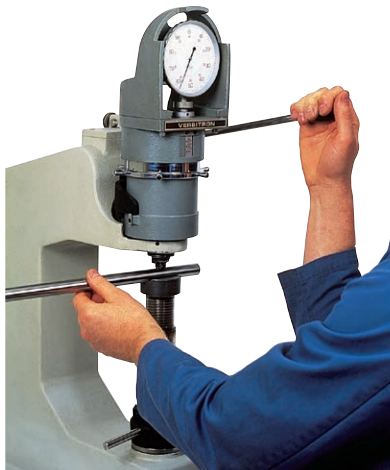

Lead screw hardness test using a Rockwell Hardness Tester. Maintains material quality and 100% reliability.

Universal Thread provides traceability of its customers' products from original manufacture to delivery of the finished product to archiving.



Drunkenness checker measures deviation within one turn.

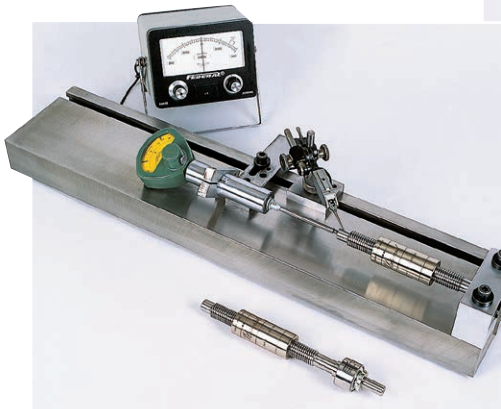

Inspection of bearing for thrust plane error.

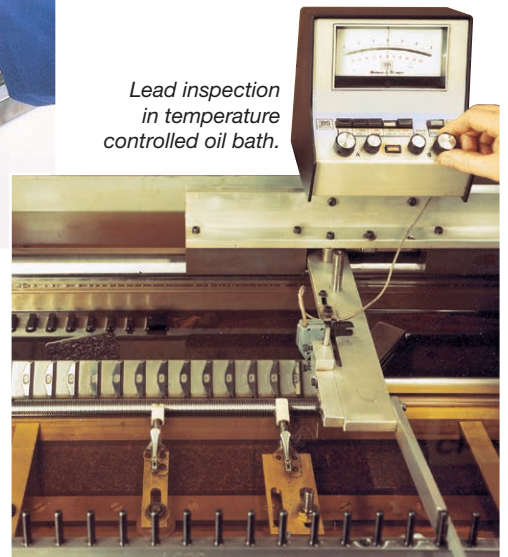

Lead inspection in temperature controlled oil bath.

Universal 
THREAD GRINDING COMPANY

30 Chambers St., Fairfield, CT 06825
Tel: 203/336-1849 • FAX: 203/366-1326
E-mail: catalogs@universal-thread.com
Website: www.universal-thread.com