

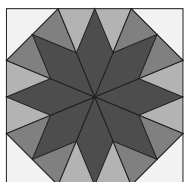

The **Wedge Star™** tool is designed to make a variety of different blocks based on 45° sub-units. They range from simple kaleidoscope blocks to complex Wedge Stars with Diamond Points going north, south, east and west. Units can be interchanged to create unlimited designs, and there are 22 different size options built into the tool, ranging from 3" finished to 24" finished. Like all Studio 180 Design tools and techniques, the shapes used in the blocks will be cut slightly oversized and then precision trimmed after sewing and pressing are complete. This makes construction easy, blocks perfectly sized, and all points precise. No other tool gives you better results. You will have higher precision, greater design versatility, and easier construction than ever before.

Basic Wedge Star™ Blocks

There are three basic blocks that you can make with the **Wedge Star™** tool.



The **Wedge Star Block** is made up of 8 Diamond Wedges and 4 Corner Triangles. A Diamond Wedge is a Wedge that contains a diamond (star point), so each is made up of a star point and 2 Small Wedges. It looks similar to a Lemoyne Star except the star points are rotated so some point north, south, east and west.

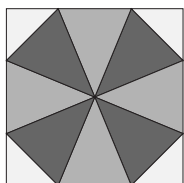

The **Wedge Block** is made up of 8 Large Wedges and 4 Corner Triangles. It is the simplest of the blocks and is a traditional kaleidoscope block.

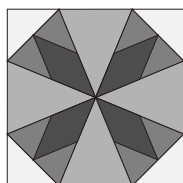
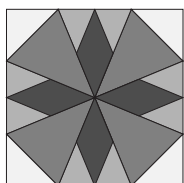

The **Mixed Block** can be made up of any combination of Diamond Wedges and Large Wedges, plus four corner triangles.

Tool Basics

Your new **Wedge Star™** tool has three sections.

- Wedge cutting section
- Diamond trim down section
- Outside edge trim section

The **Wedge Cutting** section has numbers along the edges that correspond to the width of your **Wedge strips**. You'll find whole inch, half inch and quarter inch increments.

The **Diamond Trim Down** section has solid lines, broken lines, and numbers. The broken lines indicate trim down for odd size blocks and solid lines indicate trim down for even size blocks. The numbers indicate the finished block size.

The **Outside Edge Trim Lines** are designed to trim down the outer edge of the **Pieced Diamond Wedge**. They will give you the necessary $\frac{1}{4}$ " seam allowance beyond the point of the **Diamond**.

Cutting Chart

You will be cutting strips and squares to create your blocks. The chart provides you with the information that you need for each of the 22 block sizes you can make with the tool. To use the chart, find your desired finished size block, then follow the row across to determine the strip and square sizes you need to cut. In several of the boxes you will see a dimension in parentheses one eighth inch smaller than the other size. If you don't mind cutting eighths, the smaller dimension will work.

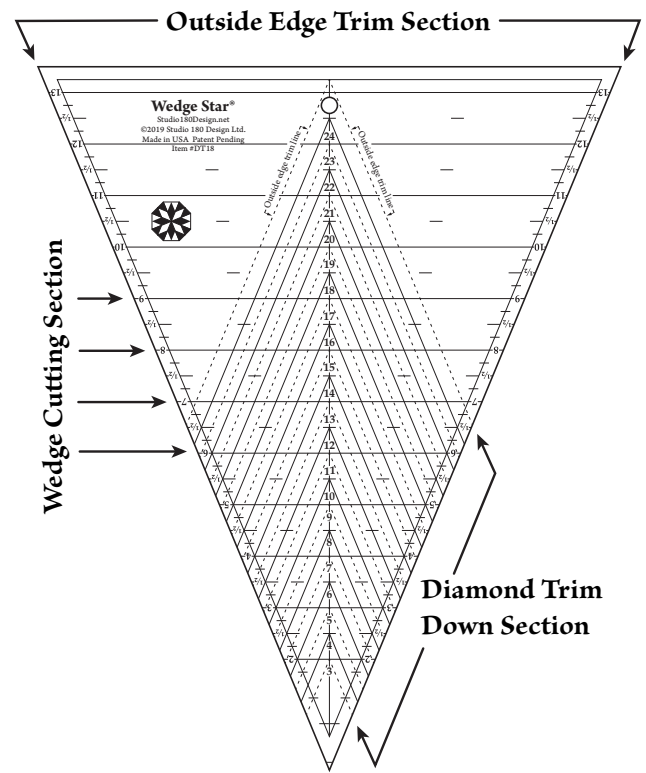

Finished Block Size	Block Cut Size	Block Center Dimension	Diamond Strip	Small Wedge Strip	Large Wedge Strip	Corner Squares
3"	3½"	1¾"	1¼"	2"	2½"	2¼"
4"	4½"	2¼"	1½"	2¼"	3"	2½"
5"	5½"	2¾"	1¾" (1⅝")	2½"	3½"	2¾"
6"	6½"	3¼"	1¾"	2¾"	4"	3"
7"	7½"	3¾"	2"	3"	4½"	3¼"
8"	8½"	4¼"	2¼"	3¼"	5"	3½"
9"	9½"	4¾"	2½"	3½"	5½"	4"
10"	10½"	5¼"	2¾" (2⅝")	3¾"	6"	4¼"
11"	11½"	5¾"	2¾"	4"	6½"	4¾"
12"	12½"	6¼"	3"	4¼"	7"	4¾"
13"	13½"	6¾"	3¼"	4½"	7½"	5"
14"	14½"	7¼"	3½"	4¾"	8"	5¾"
15"	15½"	7¾"	3¾" (3⅝")	5"	8½"	5¾"
16"	16½"	8¼"	3¾"	5¼"	9"	6"
17"	17½"	8¾"	4"	5½"	9½"	6¼"
18"	18½"	9¼"	4¼"	5¾"	10"	6¾"
19"	19½"	9¾"	4½"	6"	10½"	6¾"
20"	20½"	10¼"	4¾" (4⅝")	6¼"	11"	7¼"
21"	21½"	10¾"	4¾"	6½"	11½"	7½"
22"	22½"	11¼"	5"	6¾"	12"	8"
23"	23½"	11¾"	5¼"	7"	12½"	8¼"
24"	24½"	12¼"	5½"	7½"	13"	8½"

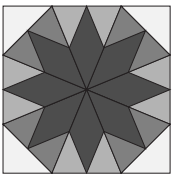

Wedge Star Block

To make the Wedge Star block you will need to cut 8 Diamonds and 16 Small Wedges.

Cutting the Diamonds

Step 1.01 - In the chart, find the row for your desired finished block size. Follow that across until you find the column labeled Diamond Strip. Cut a strip that size by width of fabric. Open the strip and lay one or more of them on the cutting mat. Trim one short edge at a 45° angle. Make 45° angle cuts along the length of the strip. **Each cut should be the same measurement as the Diamond Strip width.** For example, if you are making a 6" block, you will cut a Diamond Strip 1 3/4" wide so you will need to make your angled cuts 1 3/4" apart. Continue cutting, frequently checking your 45° angle, until you have 8 Diamonds for your block.

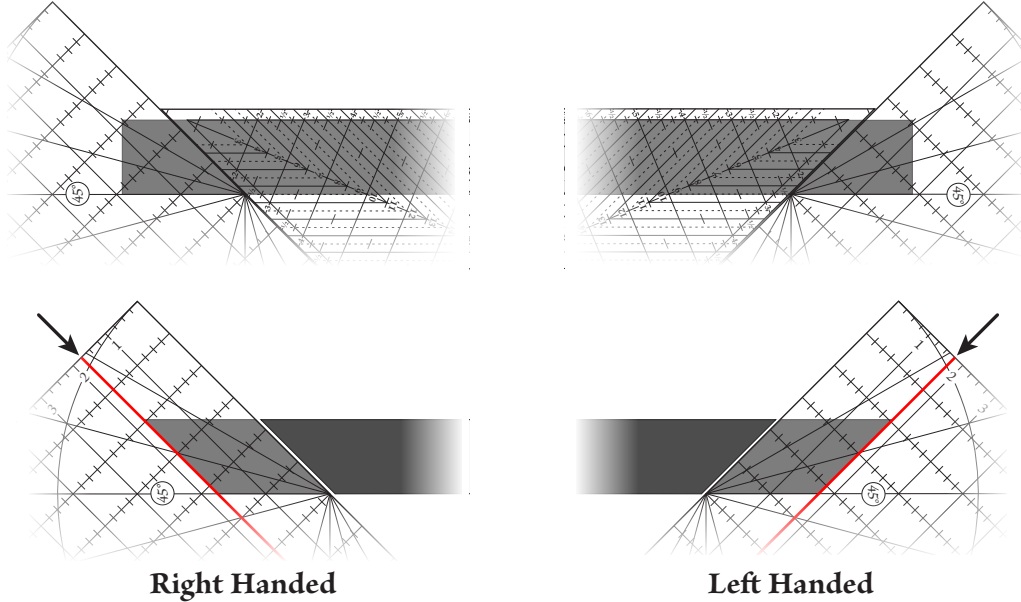

Right Handed

Left Handed

Step 1.01 - Cut Diamonds

Cutting the Small Wedges

Step 1.02 - Continue following the chart row for your desired finished size block and find the column labeled Small Wedge Strip. Cut a strip that size by width of fabric. Position the strip, either folded or open, on your cutting mat with the tool on top, as shown in the diagram below. Align the small mark near the tip of the tool with the top of the strip and the line on the tool that corresponds to the width of the strip at the bottom edge of the strip. For example, if you are making a 6" block you will cut a strip 2 3/4" wide and align the 2 3/4" line on the tool with the bottom edge of the strip.

Step 1.03 - When cutting, right handed quilters will cut from left to right. Left handed quilters will cut from right to left. Cut up one side of the tool and down the other.



Right Handed

Left Handed

Steps 1.02 & 1.03 - Cut First Small Wedge

Step 1.04 - Rotate the **Wedge Star™** tool 180° so the sharp point is closest to you. Align the same tool guidelines used previously with the upper edge of your strip. Also align one edge of the tool with the previously trimmed edge. Cut the next wedge shape from the strip. Continue rotating, aligning, and trimming until you have 16 Small Wedges for your block.

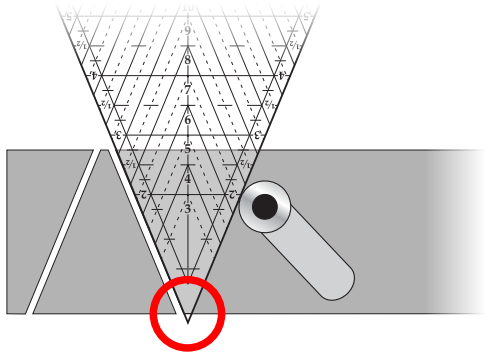

Right Handed

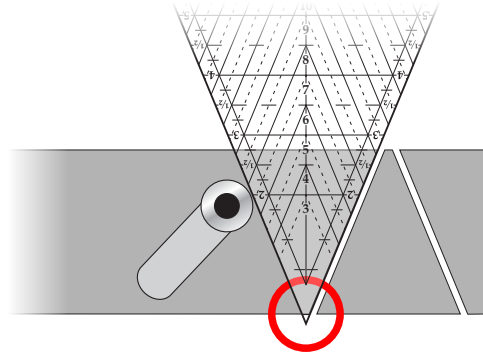

Left Handed

Step 1.04 - Rotate and Trim

Cutting the Corner Triangles

Step 1.05 - Continue to follow the row for your chosen size across the chart to the Corner Squares column. Cut 2 squares for each block. For example, if you are making the 6" block you will cut two 3" squares. Sub-cut them once on the diagonal.

Piecing the Diamond Wedges

Step 1.06 - Lay out 8 Diamonds and 16 Small Wedges as shown.

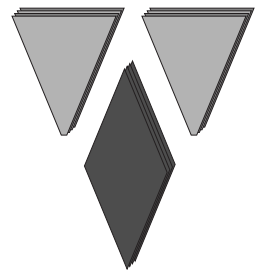

Step 1.06 - Lay out Diamonds and Wedges

Step 1.07 - Take a Small Wedge from the right hand side and position it on top of the Diamond. Match the point of the Diamond with the corner of the Wedge and align the raw edges.

Step 1.08 - With the Diamond on top, stitch along the matched edges with a 1/4" seam. Press the seam toward the Diamond and trim off the "dog ear". Repeat with the rest of the diamonds.

Step 1.09 - Using the other pile of Small Wedges, take one and position it on the other side of the Diamond point. Align the raw edges and center the shapes right sides together.

Step 1.10 - With the Diamond on top, stitch with a 1/4" seam. Press the seam toward the Small Wedge. Repeat with the rest of the Diamonds.

Step 1.11 - Use the **Wedge Star™** tool to trim each Diamond Wedge unit to an exact size. Position the unit right side up on the cutting mat. Righties point the Diamond toward the 2 o'clock position, lefties point the Diamond toward the 10 o'clock position. Align the desired finished block size lines with the sewn seams. Trim along both sides of the ruler. Repeat for all 8 Wedges. For example if you are making a 6" finished star, you will align the solid lines above the number 6 on your seam lines.

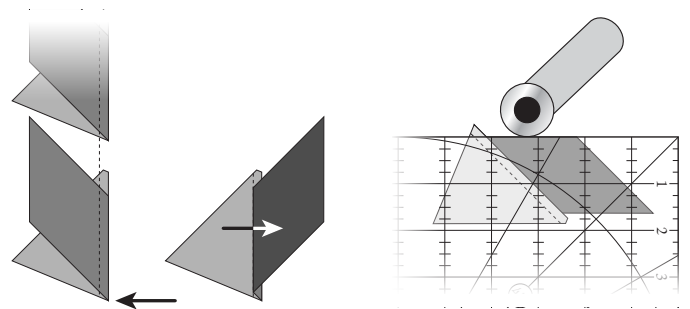

Steps 1.07 & 1.08 - Align, Stitch, Press, and Trim

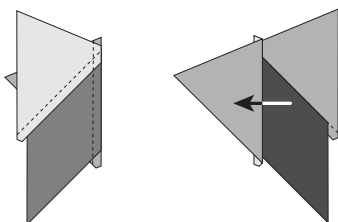

Steps 1.09 & 1.10 - Align, Stitch, and Press

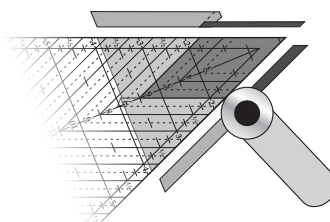

Right Handed

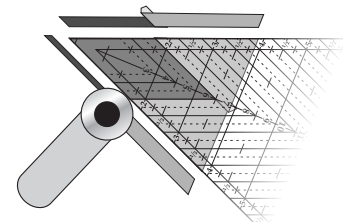

Left Handed

Step 1.11 - Trim Diamond Points

Step 1.12 - Position two Diamond Wedges right sides together. Nest the seams, match the points, and align the raw edges. Start at the point and stitch with an accurate $\frac{1}{4}$ " seam. Press seams open or in the same direction as the other seams in the unit. Choose one or the other and be consistent for best results.

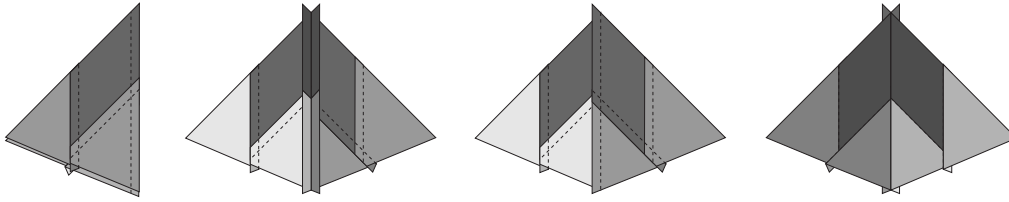

Step 1.12 - Align, Stitch, and Press

Step 1.13 - Remove "dog ears" and sliver trim the Wedge Pair. Position a Wedge Pair on a cutting mat. Righties orient the pair so the 90° corner is in the upper right, lefties position it so the 90° corner is in the upper left. Align the common diagonal on your Tucker Trimmer® with the seam to trim "dog ears" and true up the 90° angle. Note there may be just a few "whiskers" trimmed here. Trim all Wedge Pairs.

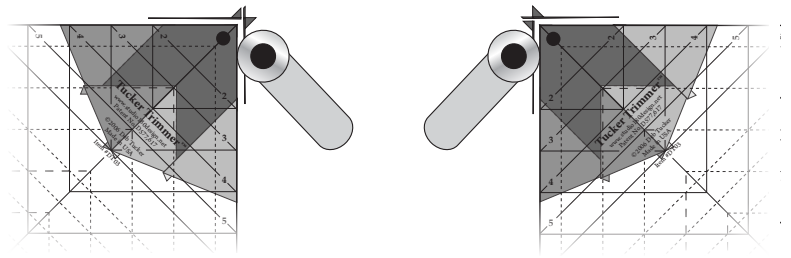

Right Handed

Left Handed

Step 1.13 - Trim

Step 1.14 - Position two Wedge Pair sections right sides together, align the raw edges, and nest the seam. Stitch one side with an accurate $\frac{1}{4}$ " seam to create the half block. Press the seam open or rotating. Again, be consistent with previous pressing choices.

Step 1.15 - Position the two halves together aligning the center, seam intersections, and the raw edges. Pin together. Stitch. Press seams open or rotating.

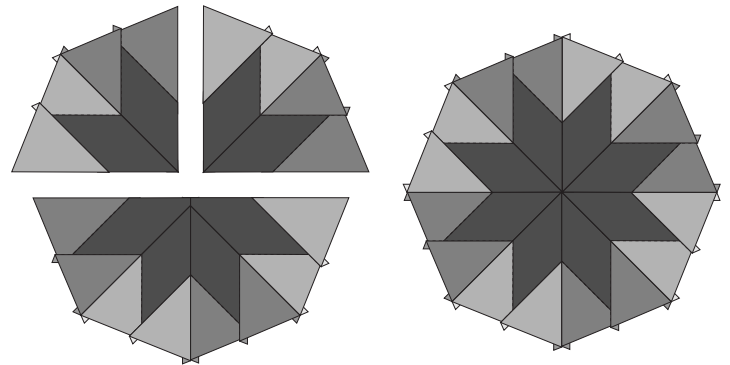

Steps 1.14 & 1.15 - Position and Stitch

Step 1.16 - To turn your octagon into a square you will need to add triangles to the corners. Determine which wedge sections will be located in the corners of your finished block. Align the *Outside Edge Trim Line* on the Wedge Star™ tool with the seams of the Diamond on one corner wedge. Trim along the edge of the tool. Repeat this for the other three corners, making sure you are only trimming every other edge. The remaining edges will be trimmed after the corners are added.

Step 1.17 - Position a Corner Triangle right sides together with a Diamond Wedge that was just trimmed. Align the raw edges and make sure that it is roughly centered over the Diamond Wedge. With the diamond on top, stitch with a $\frac{1}{4}$ " seam and press toward the Triangle. Repeat on all four corners.

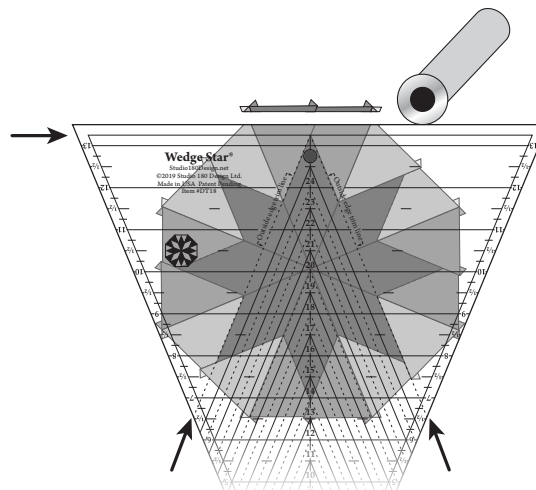

Step 1.16 - Trim

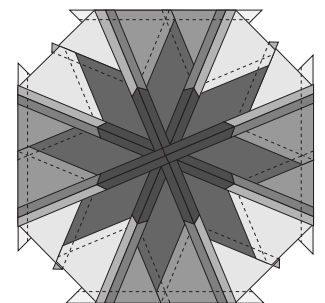

Step 1.17 - Stitch

Step 1.18 - For blocks that finish to 12" or less, we prefer to use our **Tucker Trimmer**®. Consult the Block Cut Size in the chart and simply align the common diagonal and sizing diagonal of your **Tucker Trimmer**® with the diagonal Diamonds. Make sure that the lines intersect over the center. Trim two sides. Rotate the block 180° and line up the diagonal lines with your Diamonds. Also align the clean up lines with the trimmed edges. Trim the final two sides.

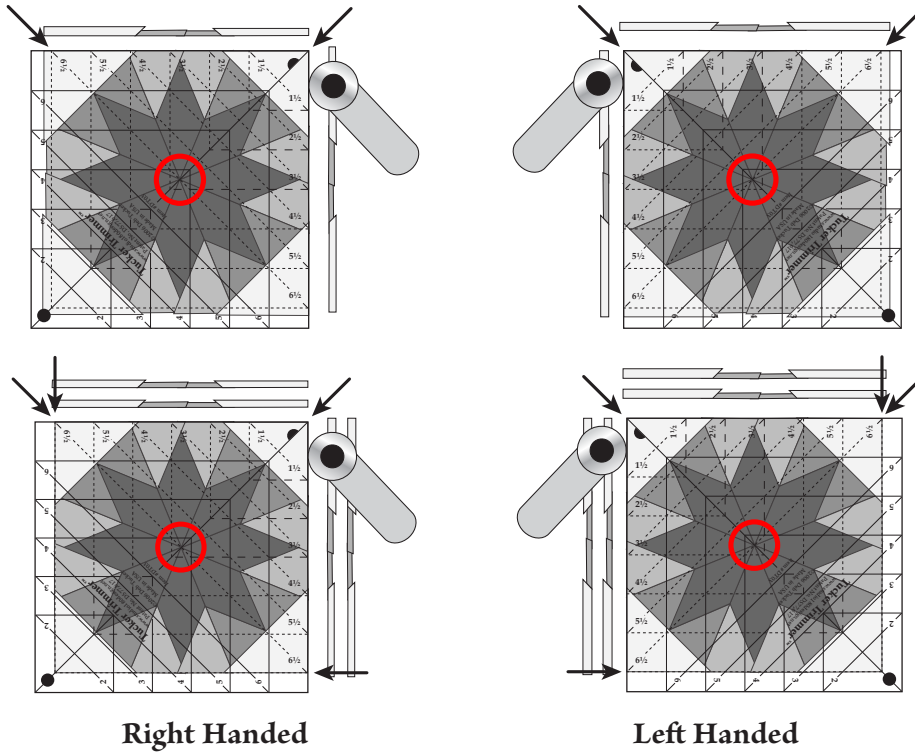

Step 1.18 - Trim, Rotate, and Trim Again

Step 1.19 - If you are not using a **Tucker Trimmer**®, or your finished block is over 12" you will need to use a regular square ruler to trim it down. Depending on your block and ruler size, you will trim two sides at a time or one corner at a time. Find the Block Center Dimension on the chart. Align the Block Center Dimension on your ruler with the center of your block. The vertical and horizontal lines for that dimension on your ruler should be aligned with the points of the north Diamond and east (for righties) or west (for lefties) Diamond. The Ruler diagonal should go through the point of the Diamond. Make sure your alignment is square and true. Trim a corner. Repeat on the remaining corner or corners.

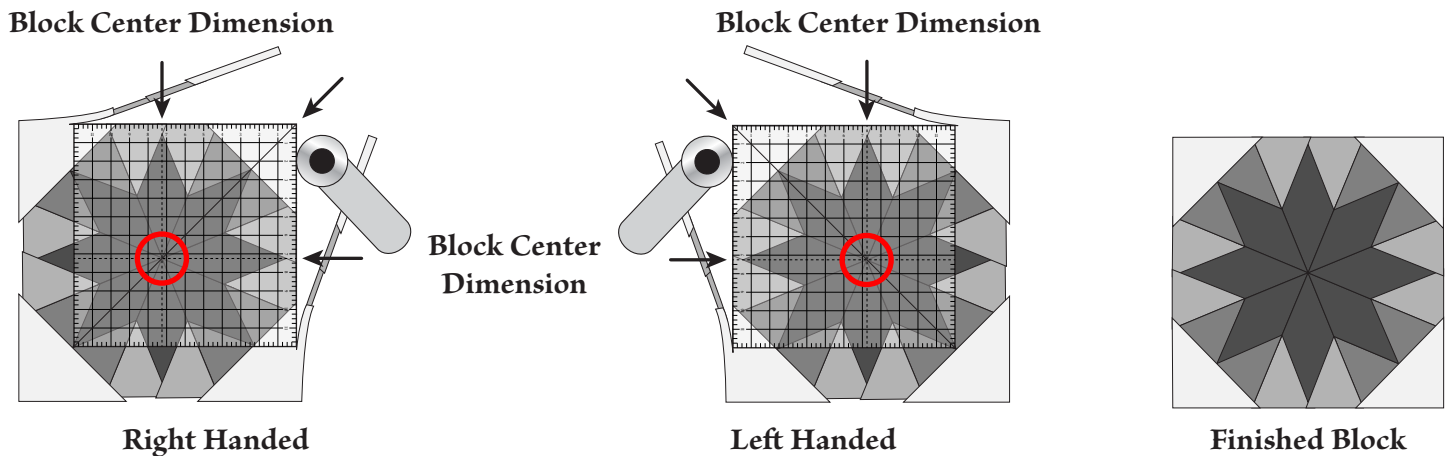

Step 1.19 - Alternate Trim

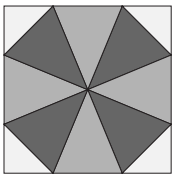

Wedge Block

To make the Wedge block you will need to cut 8 Large Wedges - generally 4 in one color and 4 in a second color - and 4 Corner Triangles.

Cutting the Large Wedges

Step 2.01 - Cut the Large Wedges in the same manner as you cut the Small Wedges. Locate your desired finished size block on the chart. Follow across the row to find the strip width to cut. For example, if you are making a 6" block you will cut a strip 4" wide. Lay the strip on your mat and align the corresponding tool line with the bottom of the strip. For our example, align the 4" tool line with the bottom edge of the strip. Cut up one side of the tool and down the other. Rotate the tool 180°. Place the same tool line on the top edge of the strip and align the tool edge against the previous cut. Cut the next wedges. Repeat until you have 4 Large Wedges. Repeat to cut 4 additional Large Wedges in your second color.

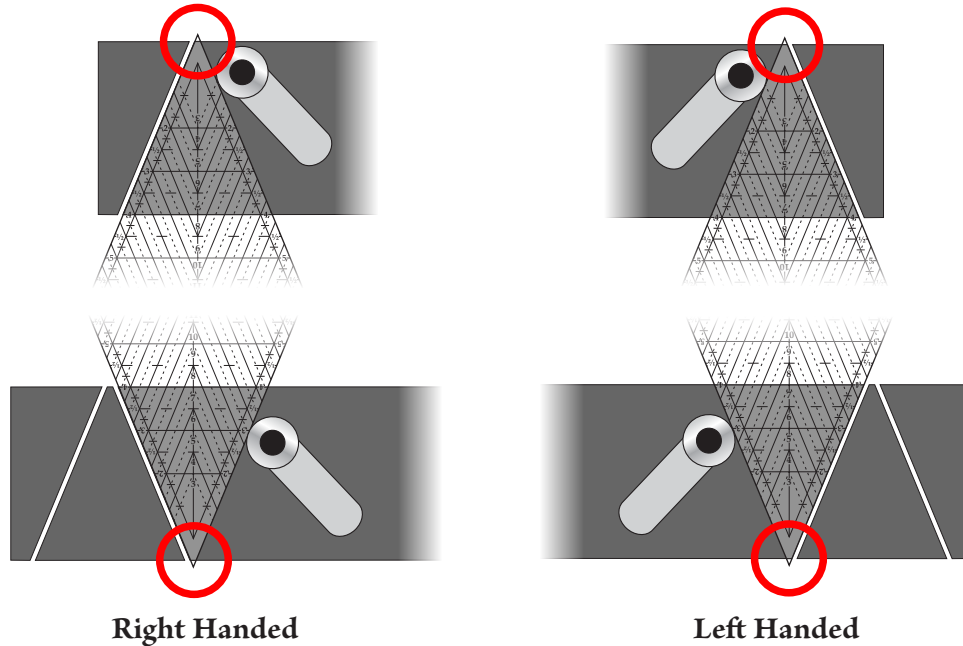

Right Handed

Left Handed

Step 2.01 - Cut Large Wedges

Cutting the Corner Triangles

Step 2.02 - Continue to follow your row across to the Corner Square column. Cut 2 squares for each block. For example, if you are making the 6" block you will cut two 3" squares. Sub-cut once on the diagonal.

Constructing the Wedge Block

Step 2.03 - Lay out the Large Wedges. Position two Large Wedges right sides together and carefully align the raw edges.

Step 2.04 - Starting at the sharp point, stitch a ¼" seam along one long edge of the Wedge pair. Repeat for the rest of the Large Wedges. If you are using two colors, make sure to position the same colored Wedge on top each time to yield four identical Wedge Pair sections.

Step 2.05 - Set the seams and press open to reduce bulk in the block center.

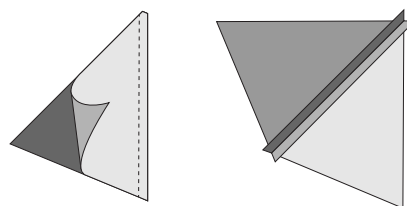

Steps 2.03 to 2.05 - Position, Stitch, Trim, and Press

Step 2.06 - Remove “dog ears” and sliver trim the Wedge Pair. Position a Wedge Pair on a cutting mat. Righties orient the pair so the 90° corner is in the upper right, lefties position it so the the 90° corner is in the upper left. Align the common diagonal on your Tucker Trimmer® with the seam to trim the “dog ears” and true up the 90° angle. Note there may be just a few “whiskers” trimmed here. Trim all Wedge Pairs.

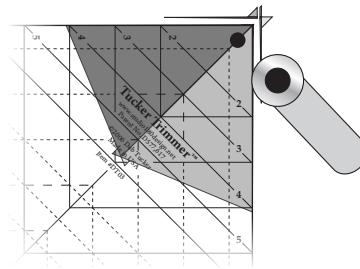

Right Handed

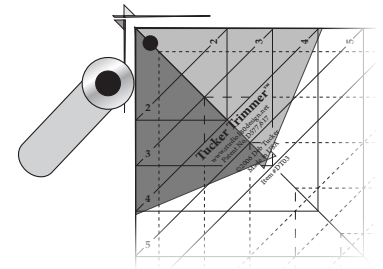

Left Handed

Step 2.06 - Trim

Step 2.07 - Position two Wedge Pair sections right sides together, align the raw edges and the seam. Pin to hold, if necessary, and stitch with a ¼” seam to create half blocks. Press the seam open.

Step 2.08 - Position the two halves together aligning the center seam intersections and the raw edges. Pin to hold if necessary and stitch with ¼” seam.

As before, you will need to add triangles to four opposite Large Wedges to transform your octagon into a square. Unlike the Diamond Wedge shapes, there are no points on the outer edges to use for alignment and measuring. For this reason, you will have to add a few temporary guidelines on your block and/or tool for trimming accuracy. You will want to have InvisiGrip™ on your the back of your tool for this step.

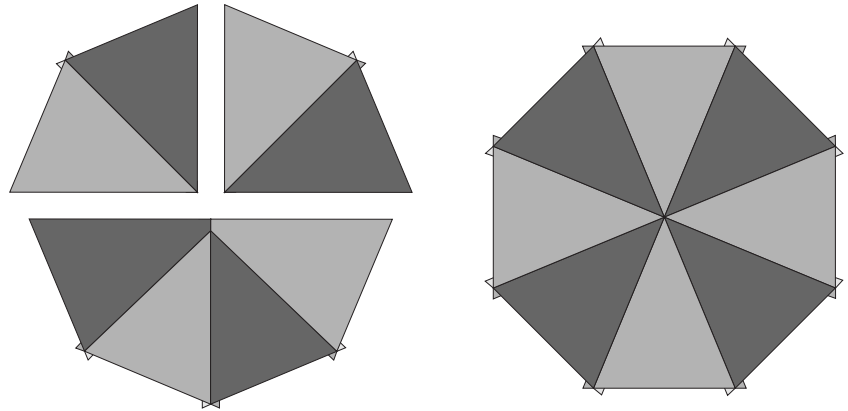

Steps 2.07 & 2.08 - Position and Stitch

Step 2.09 - Determine which Large Wedges are going to have Corner Triangles attached.

Step 2.10 - Make a halfway registration mark on these four wedges. Wedges can be folded in half matching the seams and then lightly pressed to give a centerfold line. Or the centerline of the tool can be placed on the sewn seam with the point of the tool at the center. Mark with a removable marking tool.

Step 2.11 - Place your Wedge Star® tool upside down, with the Invisigrip™ facing up. Find the Block Center dimension for your project on the chart.

Step 2.12 - Measure down that distance from the flat edge of the tool and make a mark on the back of the tool, across the centerline as illustrated. Use a fine point Sharpie® marker. For our example, make a mark 3¼” from the tool edge.

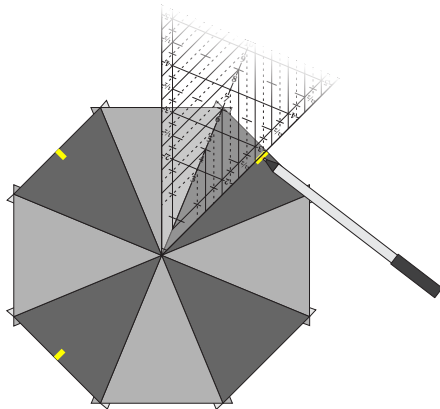

Step 2.10 - Mark

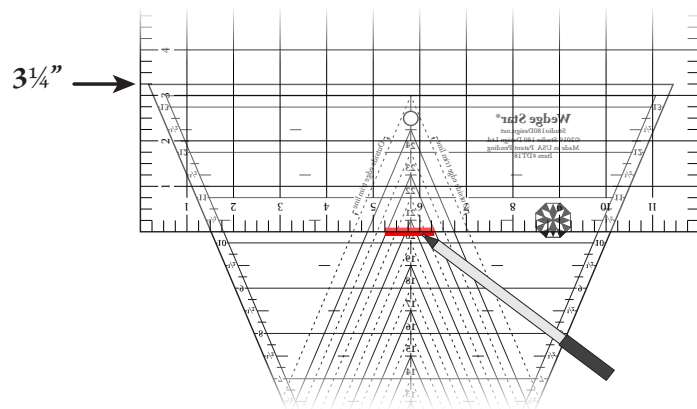

Steps 2.11 & 2.12 - Mark the Tool

Step 2.13 - Working on your cutting mat, place the intersection of the centerline of the tool and the Sharpie® marked line on the center of the sewn block. At the same time, align the centerline of the tool with the halfway registration mark on the fabric block.

Step 2.14 - Cut along the flat edge of the tool. You should only be trimming off a small amount of fabric. If you are trimming more than ¼", recheck your tool mark!

Step 2.15 - Repeat for the other three Corner Wedges.

Step 2.16 - Position a Corner Triangle right sides together with a trimmed Wedge. Align the raw edges and make sure that it is roughly centered over the Wedge.

Step 2.17 - With the Wedge on top, stitch with a ¼" seam and press in, out or open. Repeat until you have triangles on all four corners.

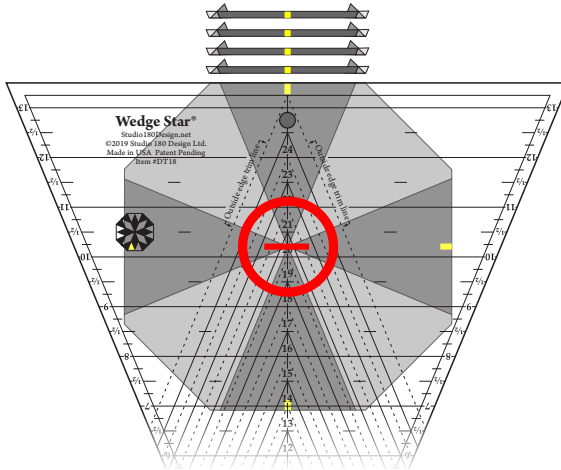

Steps 2.13 to 2.15 - Align, Trim, Rotate, and Trim Three Remaining Corner Wedges

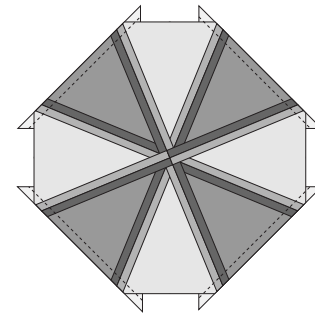

Steps 2.16 & 2.17 - Stitch

Step 2.18 - For blocks that finish to 12" or less, we prefer to use our Tucker Trimmer®. Consult the Block Cut Size in the chart and align the common diagonal and sizing diagonal with the marks made for the previous trimming. Make sure that the intersection of the tool lines is over the center. Trim two sides. Rotate the block 180° and line up the diagonal lines as well as the clean up lines with the trimmed edges. Trim the final two sides.

Right Handed

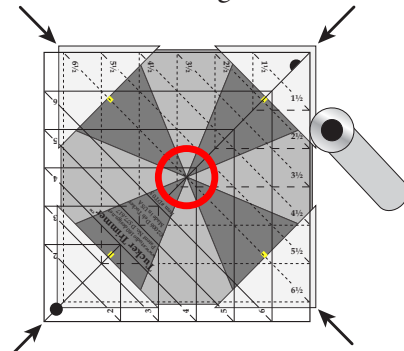

Left Handed

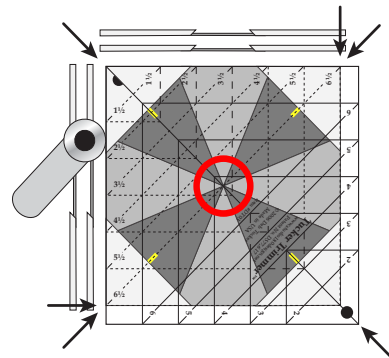
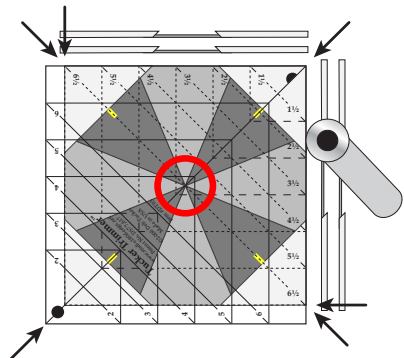
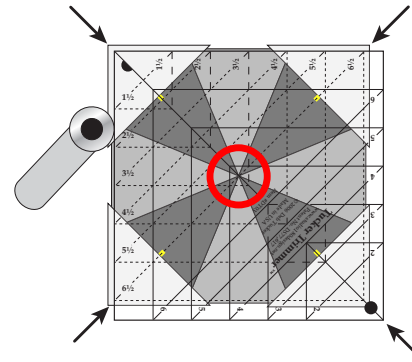

Step 2.18 - Trim, Rotate, and Trim Again

Step 2.19 - If you are not using a **Tucker Trimmer**[®], or your finished block is over 12", you will need to use a regular square ruler to trim it down. Depending on your block and ruler size, you will trim two sides at a time or one corner at a time. Mark the center of your North, South, East and West wedges like you did the corner wedges. Find the Block Center Dimension on the chart. Align the Block Center Dimension on your ruler with the center of your block. The vertical and horizontal lines for that dimension on your ruler should be aligned with the registration marks on the north side and east (for righties) or west (for lefties) side of the block. The Ruler diagonal should go through the Corner Wedge halfway registration mark made earlier. Make sure your alignment is square and true. Trim a corner. Repeat on the remaining corner or corners.

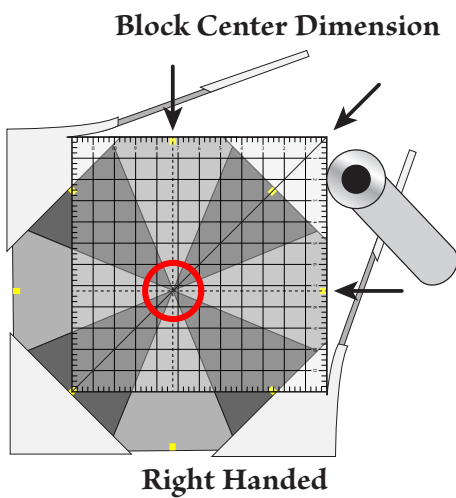
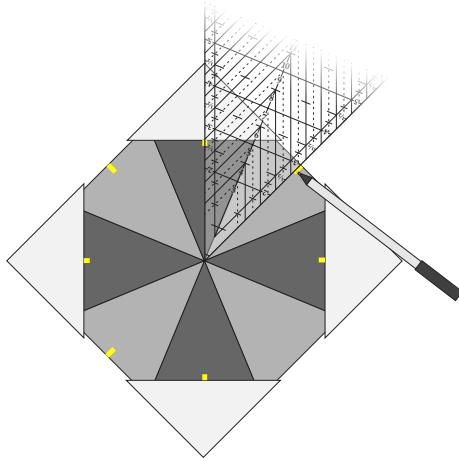

Block Center Dimension

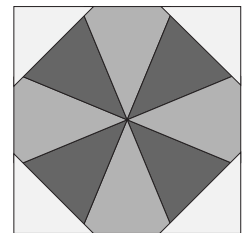
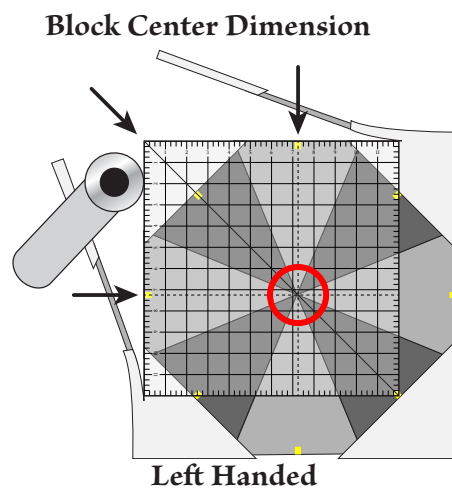

Step 2.19 - Mark and Trim (Alternate)

Finished Block

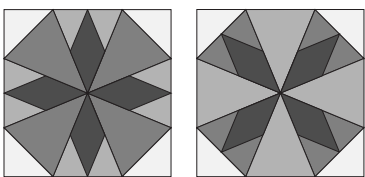

Mixed Wedge Block

To make a mixed block you can use any combination of Large Wedges and Diamond Wedges as long as you plan for a total of 8 wedges. Adding these mixed blocks to the equation will result in tremendous design opportunities. To construct them, you should simply analyze what type of wedges are in your block, how many of each you'll need, what

size your block is when finished and then follow the construction steps as described above for making the Wedge Star or Wedge Block sections. You can see a sample of a Mixed Wedge Block in our included free project design.

Trimming your octagon block to add your triangle corners will depend on the position of your Diamond Wedges and Large Wedges.

If you are adding corner triangles to Diamond Wedge sections follow the corner trimming instructions as described in step 1.16: align the *Outside Edge Trim Line* on the tool with the seams at the tip of the diamond and trim.

If you are adding corner triangles to simple Wedge sections, follow the corner trimming instructions under steps 2.10 - 2.15 as described above. Mark the centers on the fabric block, mark the block center dimension on the tool, align the tool over the center and marks, then trim.

Once your corner wedges are trimmed, proceed to add the oversized corner triangles, press and then trim your block to the Block Cut Size listed for your block size. For trimming blocks 12" or less, trim with your **Tucker Trimmer®** as described above in step 1.18 if you are aligning with Diamond Point sections, or step 2.18 if you are aligning with Large Wedge sections. For trimming blocks over 12", align your ruler as described in step 1.19 with your Diamond points, or in step 2.19 with the registration marks you made in the centers of your Wedge Sections. Trim. Repeat for all corners.

Wedge Star Bonus Pattern – Freelancer

Finished Size: 22 options from 9" x 9" up to 72" x 72" (without borders)

Now that you know the basics, why not give our free project a try? The quilt size and fabric yardage will, of course, depend on the size blocks you choose. Figure out what size blocks you want to use in your project, then consult the chart for the strip sizes you'll need to cut for your Wedge, Diamond, and Mixed Blocks. You can cut just one strip at a time until you know how many of each Diamond or Wedge shape can be cut from each strip, or consult our free downloadable chart. Follow the instructions for constructing your blocks, then stitch your blocks together as shown in the illustration on page 12. Once your top is pieced, you can pick how many borders to add - one, two or more.

With all the possibilities the **Wedge Star™** tool offers, this project can truly be yours; just change the size and coloring to make a spectacular project.

Below is a listing of the pieces you need to cut for the Freelancer project.

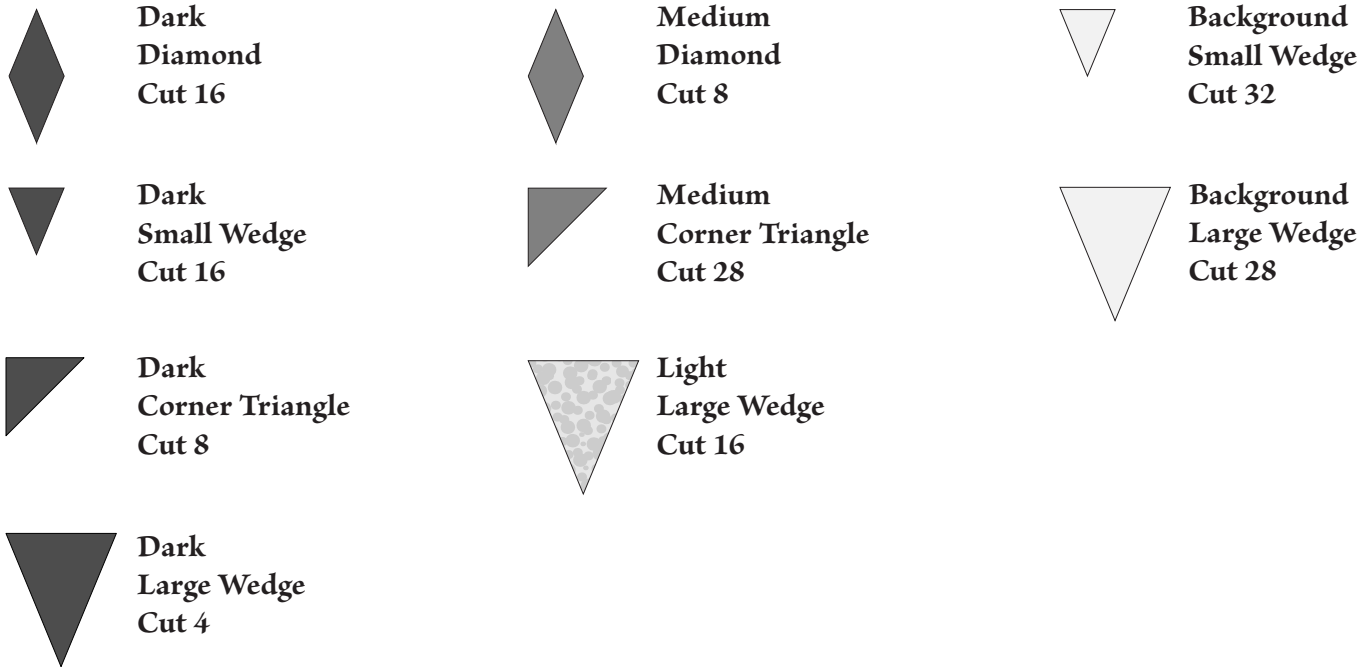

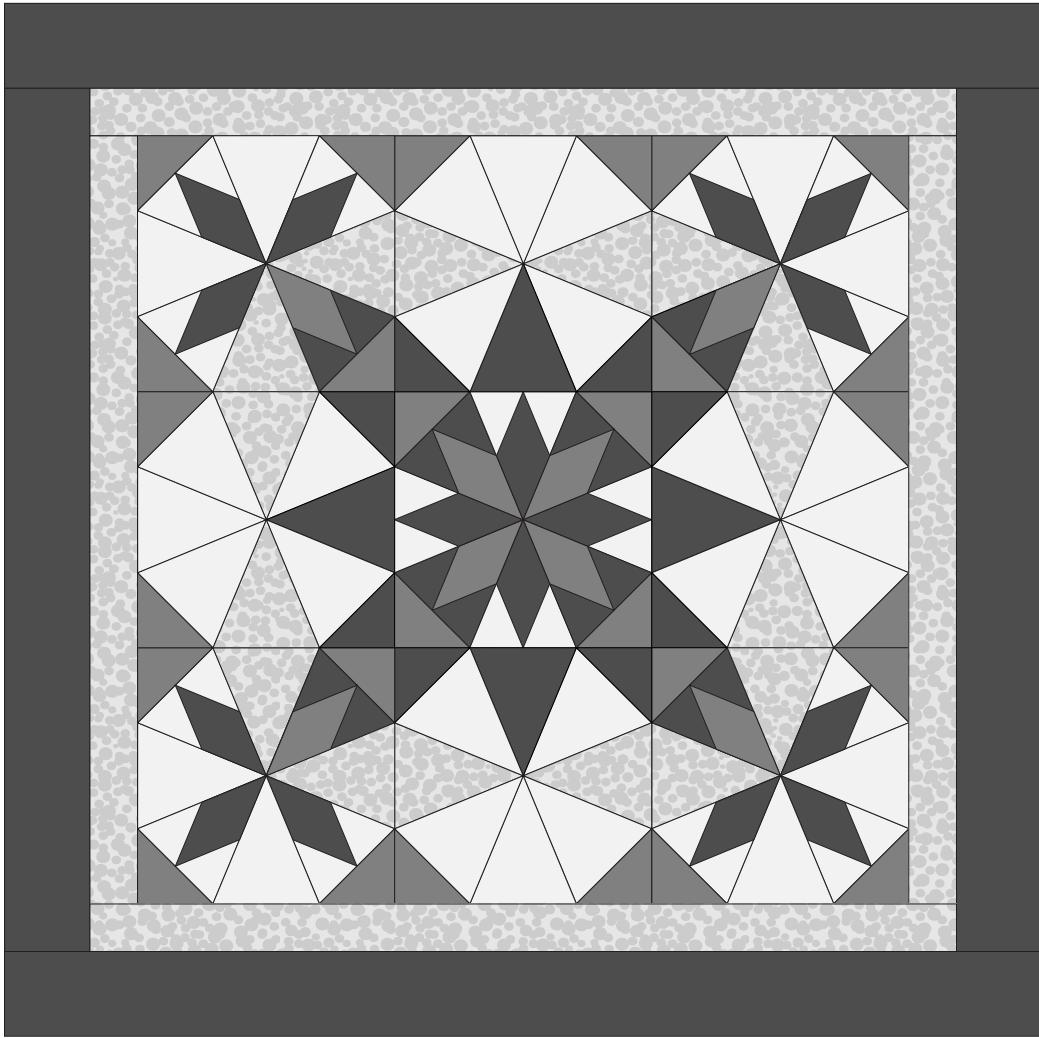

Freelancer Project Layout

What Else Is There?

The sky is the limit! Imagine how interesting your blocks would be if you strip pieced your Large Wedges! Or maybe fussy cut your Diamond Points ... Or tried some fun color play ... There are all sorts of interesting things you can do to add even more interest to your blocks. Think outside the block to stretch the limits of your new **Wedge Star™** tool. We can't wait to see what unique and interesting designs you create using your new **Wedge Star™** tool and would love to see a photo when you are finished. You can share a photo of your project either on Instagram ([#WedgeStar](#)) or on our Gallery page at [Studio180Design.net](#).

We hope you enjoy working with your new **Wedge Star™** tool. To see more innovative tools, techniques, videos, patterns and products developed by Studio 180 Design, visit our website: [Studio180Design.net](#). Also be sure to check out your local quilt shop for Tucker University classes and in store programs revolving around our tools.

