

Item Number	Replacment Parts	Quantity Per
1	Main Pin	1
2	Main Pin Bushing	2
3	Main Pin Collar	1
4	Cylinder Pin on Thumb	1
5	Cylinder Pin on Base Plate	1
6	Cylinder	1
7	Cylinder Seal Kit	1
8	Cylinder Bushing	2
9	Base Plate	1
10	Shim Kit	1

Machine Make and Model \_\_\_\_\_

Thumb Serial Number \_\_\_\_\_

Main Pin  $\varnothing$  \_\_\_\_\_

Quick Coupler  Yes  No

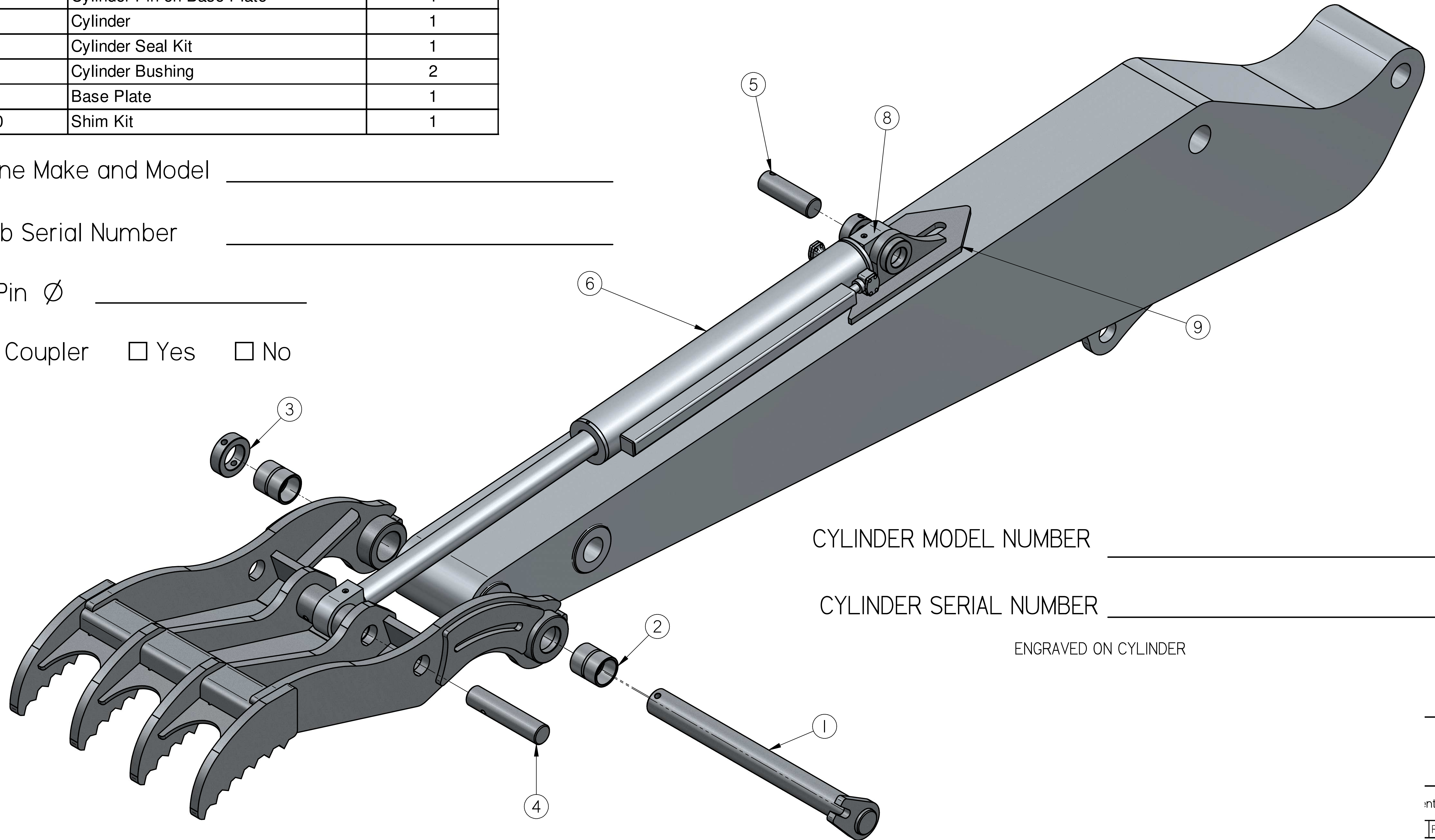

CYLINDER MODEL NUMBER \_\_\_\_\_

CYLINDER SERIAL NUMBER \_\_\_\_\_

ENGRAVED ON CYLINDER

nt Parts

REV: