

GEOMETRY UNIT 1 WORKBOOK

FALL 2015

Algebra Review

Geometry

Algebra Review: 0-5 Linear Equations

If the same number is added to or subtracted from each side of an equation the resulting equation is true.

Example 1:

a. $x + 8 = -5$

b. $n - 15 = 3$

c. $p + 27 = 12$

If each side of an equation is multiplied or divided by the same number, the resulting equation is true.

Example 2:

a. $5g = 35$

b. $-\frac{c}{6} = 8$

c. $\frac{4x}{7} = -3$

To solve equations with more than one operation, often called **multi-step equations**, undo operations by working backward.

Example 3:

a. $9p + 8 = 35$

b. $8x + 2 = 14x - 7$

When solving equations that contain grouping symbols, first use the Distributive Property to remove the grouping symbols.

Example 4:

a. $4(x - 7) = 8x + 6$

b. $\frac{1}{3}(18 + 12x) = 6(2x - 7)$

Geometry

Algebra Review: 0-7 Ordered Pairs

Points in the coordinate plane are named by **ordered pairs** of the form (x, y) . The first number, or **x-coordinate**, corresponds to a number on the x-axis. The second number, or **y-coordinate**, corresponds to a number on the y-axis.

Example 1: Write the ordered pair for each point.

a. Point C

b. Point D

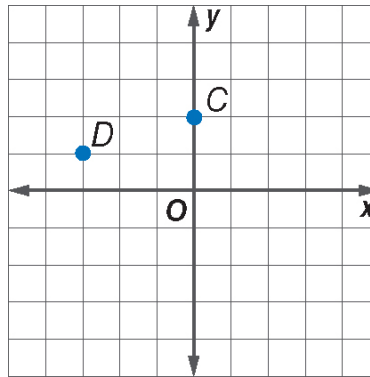

The x-axis and y-axis separate the coordinate plane into four regions, called **quadrants**. The point at which the axes intersect is called the **origin**. The axes and points on the axes are not located in any of the quadrants.

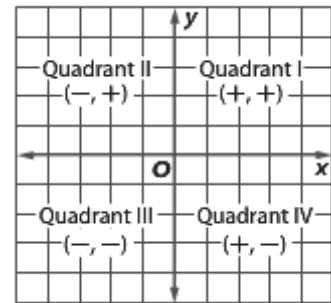

Example 2: Graph and label each point on a coordinate plane. Name the quadrant in which each point is located.

a. $P(4, 2)$

b. $M(-2, 4)$

c. $N(-1, 0)$

Example 3:

Graph a polygon with vertices $P(-1, 1)$, $Q(3, 1)$, $R(1, 4)$, and $S(-3, 4)$.

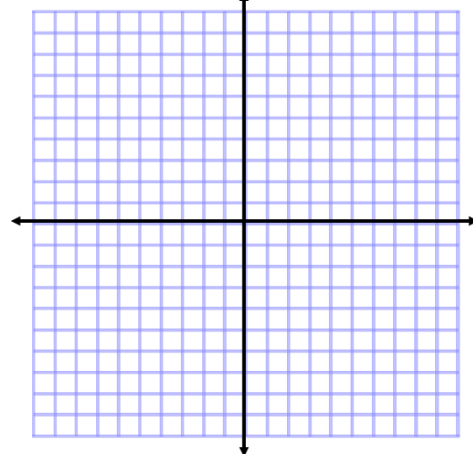
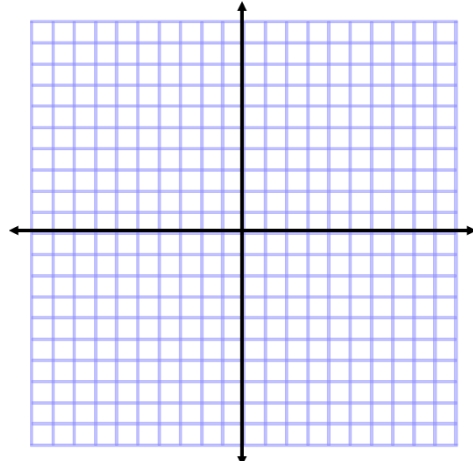

Remember lines have infinitely many points on them. So when you are asked to find points on a line, there are many answers.

*Make a table. Choose values for x . Evaluate each value of x to determine the y . Plot the ordered pairs.

Example 4:

Graph four points that satisfy the equation $y = -x - 2$

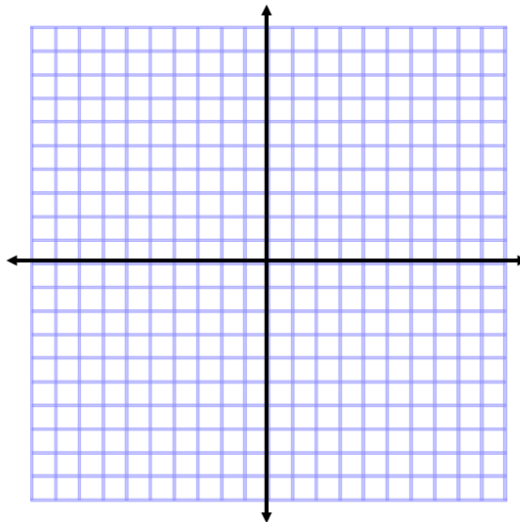

Geometry

Algebra Review: 0-8 Systems of Linear Equations

Two or more equations that have common variables are called **system of equations**. The solution of a system of equations in two variables is an ordered pair of numbers that satisfies both equations. A system of two linear equations can have zero, one, or an infinite number of solutions. There are three methods by which systems of equations can be solved: graphing, elimination, and substitution.

Example 1: Solve each system of equations by graphing. Then determine whether each system has *no solution*, *one solution*, or *infinitely many solutions*.

a. $y = -3x + 1$
 $y = x - 3$

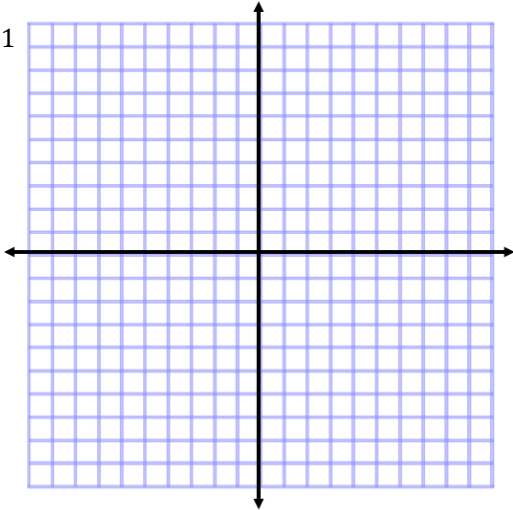

b. $y = 2x + 3$
 $-4x + 2y = 6$

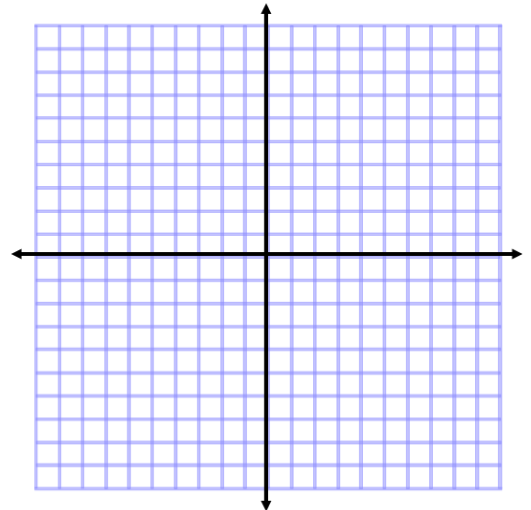

It is difficult to determine the solution of a system when the two graphs intersect at noninteger values. There are algebraic methods by which an exact solution can be found. One such method is **substitution**.

Example 2: Use substitution to solve the system of equations.

a. $y = 3x$
 $-2y + 9x = 5$

b. $3x + 2y = 10$
 $2x + 3y = 10$

Sometimes adding or subtracting two equations together will eliminate one variable. Using this step to solve a system of equations is called **elimination**.

Example 3: Use elimination to solve the system of equations.

a. $-3x + 4y = 12$
 $3x - 6y = 18$

b. $3x + 7y = 15$
 $5x + 2y = -4$

Geometry

Algebra Review: 0-9 Square Roots and Simplifying Radicals

A radical expression is an expression that contains a square root. The expression is in simplest form when the following three conditions have been met.

- No radicands have perfect square factors other than 1.
- No radicands contain fractions.
- No radicals appear in the denominator of a fraction.

The **Product Property** states that for two numbers a and $b \geq 0$, $\sqrt{ab} = \sqrt{a} \cdot \sqrt{b}$.

Example 1: Simplify the radical. Leave your answer in radical form.

a. $\sqrt{50}$

b. $\sqrt{8} \cdot 2\sqrt{4}$

For radical expressions in which the exponent of the variable inside the radical is even and the resulting simplified exponent is odd, you must use absolute value to ensure nonnegative results.

Example 2: Simplify the radical. Leave your answer in radical form.

a. $\sqrt{18a^5b^4c^7}$

b. $\sqrt{20x^3y^5z^6}$

The **Quotient Property** states that for any numbers a and b , where $a \geq 0$ and $b \geq 0$, $\sqrt{\frac{a}{b}} = \frac{\sqrt{a}}{\sqrt{b}}$.

Example 3: Simplify the radical. Leave your answer in radical form.

a. $\sqrt{\frac{49}{36}}$

b. $\sqrt{\frac{25}{16}}$

Rationalizing the denominator of a radical expression is a method used to eliminate radicals from the denominator of a fraction. To rationalize the denominator, multiply the expression by a fraction equivalent to 1 such that the resulting denominator is a perfect square.

Example 4: Simplify the radical. Leave your answer in radical form.

a. $\frac{3}{\sqrt{5}}$

b. $\frac{\sqrt{17x}}{\sqrt{20}}$

Sometimes conjugates are used to simplify radical expressions. Conjugates are binomials of the form $p\sqrt{q} + r\sqrt{t}$ and $p\sqrt{q} - r\sqrt{t}$.

Example 5: Simplify the radical. Leave your answer in radical form.

a. $\frac{8}{6 - \sqrt{3}}$

b. $\frac{3}{5 - \sqrt{2}}$

Geometry
General Algebra Skills Guided Notes

Skill 1: Solving Equations

a) $-3(4x + 3) + 4(6x + 1) = 43$

Skill 2: Simplify by Multiplying

a) $(x - 3)(6x - 2)$

b) $(4a + 2)(6a^2 - a + 2)$

Skill 3: Factoring

a) $n^2 + 4n - 12$

b) $3n^2 - 8n + 4$

Skill 4: Solving Quadratic Equations

a) $10n^2 + 2 = 292$

b) $(2m + 3)(4m + 3) = 0$

c) $n^2 + 3n - 12 = 6$

d) $2x^2 + 3x - 20 = 0$

e) $5x^2 + 9x = -4$

Skill 5: Simplifying Radicals

a) $\sqrt{18}$

b) $\sqrt{24}$

Geometry
Skills Review Worksheet

Name: _____

For numbers 1 – 3, solve each equation.

1. $8x - 2 = -9 + 7x$

2. $12 = -4(-6x - 3)$

3. $-5(1 - 5x) + 5(-8x - 2) = -4x - 8x$

For numbers 4 – 6, simplify each expression by multiplying.

4. $2x(-2x - 3)$

5. $(8p - 2)(6p + 2)$

6. $(n^2 + 6n - 4)(2n - 4)$

For numbers 7 – 9, factor each expression.

7. $b^2 + 8b + 7$

8. $b^2 + 16b + 64$

9. $2n^2 + 5n + 2$

For numbers 10 – 14, solve each equation.

10. $9n^2 + 10 = 91$

11. $(k + 1)(k - 5) = 0$

12. $n^2 + 7n + 15 = 5$

13. $n^2 - 10n + 22 = -2$

14. $2m^2 - 7m - 13 = -10$

For numbers 15 – 18, simplify each radical.

15. $\sqrt{72}$

16. $\sqrt{80}$

17. $\sqrt{32}$

18. $\sqrt{90}$

I. Solving Linear Equations

1. $2x + 5 = 11$

2. $3x + 5 = -16$

3. $2(x - 3) = 84$

4. $5x - 32 = 80$

5. $3(2x + 5) - 3x = 6$

6. $3x - 4(x - 4) + 4 = 13$

II. Solving Systems of Equations by Elimination.

7.
$$\begin{cases} 2x + 7y = 3 \\ -4x - 2y = -18 \end{cases}$$

8.
$$\begin{cases} x - y = 39 \\ x + y = 1785 \end{cases}$$

9.
$$\begin{cases} 6x + 4y = 7 \\ 15x - 12y = 1 \end{cases}$$

10.
$$\begin{cases} 11x - 3y = -39 \\ 6x + 12y = -19 \end{cases}$$

III. Solving Systems of Equations by Substitution

11.
$$\begin{cases} x - 6y = -2 \\ -5x + 30y = 10 \end{cases}$$

12.
$$\begin{cases} 9x - 2y = -6 \\ 5x + 4y = 12 \end{cases}$$

13.
$$\begin{cases} 2x + 3y = 8 \\ 9x - 3y = 14 \end{cases}$$

14.
$$\begin{cases} 10x - 5y = 3 \\ 6x + 30y = 81 \end{cases}$$

IV. Simplifying Radicals

15. $\sqrt{52}$

16. $\sqrt{\frac{6}{10}}$

17. $\sqrt{\frac{12}{8}}$

18. $\frac{5}{\sqrt{15}}$

19. $\frac{3}{\sqrt{3}}$

20. $\frac{3\sqrt{5}}{\sqrt{20}}$

21. $\sqrt{\frac{50}{75}}$

22. $\frac{16}{\sqrt{24}}$

23. $\frac{10\sqrt{10}}{\sqrt{80}}$

V. Solving Quadratic Equations by the Quadratic Formula

24. $x^2 - x = 6$

25. $x^2 + 8 = 6x$

26. $4x^2 = 4x - 1$

27. $4x^2 - 3x = 7$

VI. Solving Quadratic Equations by Factoring (when $a = 1$)

28. $x^2 - 2x - 35 = 0$

29. $x^2 - 10x - 24 = 0$

30. $x^2 - 9x = 2x + 12$

31. $32x + 240 = -x^2$

VII. Solving Quadratic Equations by Factoring (when $a \neq 1$)

$$32. 2x^2 + x - 3 = 0$$

$$33. 24x - 35 = 4x^2$$

$$34. 7x + 21 = 14x^2$$

$$35. -72x^2 + 36x + 36 = 0$$

VIII. Solving Special Cases of Quadratic Equations

$$36. x^2 - 3 = 125$$

$$37. 45x^2 - 586 = 19,259$$

$$38. 12x^2 + 420 = 40x^2 - 1372$$

$$39. 4x^2 + 5 = 54$$

$$40. 5x^2 + 5 = x^2 + 25$$

$$41. 3x^2 - 6x = 11x$$

IX. Solving Radical Equations and Proportions

$$42. \sqrt{3x-2} = 5$$

$$43. \sqrt{5x} - 2 = 3$$



$$44. \frac{2y}{y-3} = \frac{-1}{y}$$

$$45. \frac{x}{2x-6} = \frac{x+8}{15}$$

CHAPTER 1

Geometry
Section 1.1 Notes: Points, Lines, and Planes

Undefined terms: words that are not formally defined, such as, point, line, and plane.

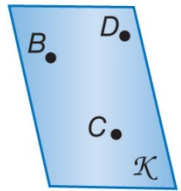
KeyConcept Undefined Terms	
<p>A point is a location. It has neither shape nor size.</p> <p>Named by a capital letter</p> <p>Example point <i>A</i></p>	
<p>A line is made up of points and has no thickness or width. There is exactly one line through any two points.</p> <p>Named by the letters representing two points on the line or a lowercase script letter</p> <p>Example line <i>m</i>, line <i>PQ</i> or \overleftrightarrow{PQ}, line <i>QP</i> or \overleftrightarrow{QP}</p>	
<p>A plane is a flat surface made up of points that extends infinitely in all directions. There is exactly one plane through any three points not on the same line.</p> <p>Named by a capital script letter or by the letters naming three points that are not all on the same line</p> <p>Example plane \mathcal{K}, plane <i>BCD</i>, plane <i>CDB</i>, plane <i>DCB</i>, plane <i>DBC</i>, plane <i>CBD</i>, plane <i>BDC</i></p>	

Collinear Points: points that lie on the same line.

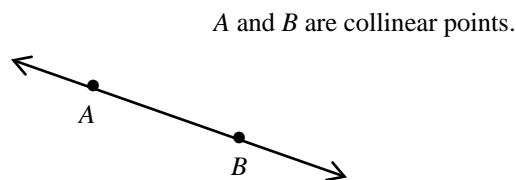

Coplanar Points: points that lie on the same plane.

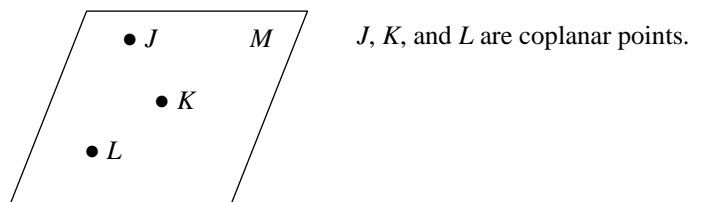

Example 1:

a) Use the figure to name a line containing point *K*.

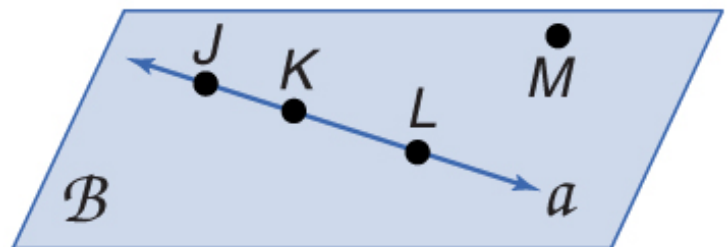

b) Use the figure to name a plane containing point *L*.

Example 2: Name the geometric shape modeled by a 10×12 patio.

Example 3: Name the geometric shape modeled by a button on a table.

Two or more geometric figures **intersect** if they have one or more points in common.

The **intersection** of the figures is the set of points the figures have in common.

Example 4: Draw and label a figure for the following situation. Plane R contains lines AB and DE , which intersect at point P . Add point C on plane R so that it is not collinear with \overline{AB} or \overline{DE} .

Example 5: Draw and label a figure for the following situation. \overline{QR} on a coordinate plane contains $Q(-2, 4)$ and $R(4, -4)$. Add point T so that T is collinear with these points.

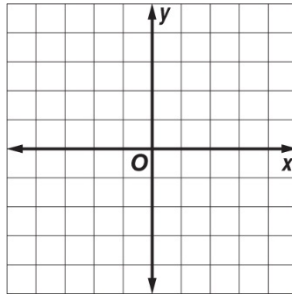

Definitions or **defined terms** are explained using undefined terms and / or other defined terms. **Space** is defined as a boundless, three dimensional set of all points. Space can contain lines and planes.

Example 6:

a) How many planes appear in this figure?

b) Name three points that are collinear.

c) Are points A , B , C , and D coplanar? Explain.

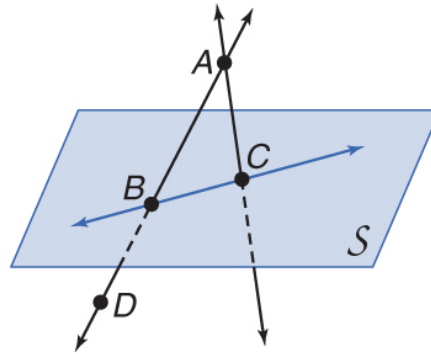

d) At what point do \overline{DB} and \overline{CA} intersect?

Geometry
Section 1.1 Worksheet

Name: _____

For numbers 1 – 3, refer to the figure.

1. Name a line that contains points T and P .
2. Name a line that intersects the plane containing points Q , N , and P .
3. Name the plane that contains \overline{TN} and \overline{QR} .

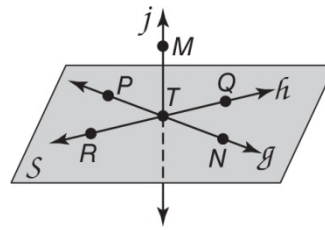

For numbers 4 and 5, draw and label a figure for each relationship.

4. \overline{AK} and \overline{CG} intersect at point M .

5. A line contains $L(-4, -4)$ and $M(2, 3)$. Line q is in the same coordinate plane but does not intersect \overline{LM} . Line q contains point N .

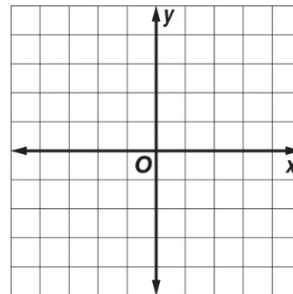

For numbers 6 – 8, refer to the figure.

6. How many planes are shown in the figure?

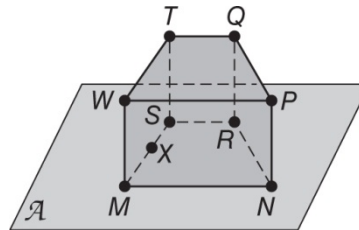

7. Name three collinear points.

8. Are points N , R , S , and W coplanar? Explain.

VISUALIZATION For numbers 9 – 13, name the geometric term(s) modeled by each object.

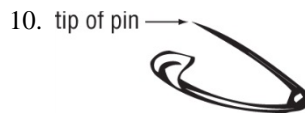
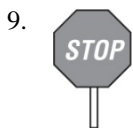

12. a car antenna

13. a library card

14. **STREETS** The map shows some of the roads in downtown Little Rock. Lines are used to represent streets and points are used to represent intersections. Four of the street intersections are labeled. What street corresponds to line AB ?

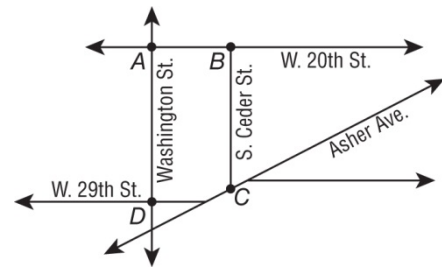

15. **FLYING** Marsha plans to fly herself from Gainesville to Miami. She wants to model her flight path using a straight line connecting the two cities on the map. Sketch her flight path on the map shown below.



16. **MAPS** Nathan's mother wants him to go to the post office and the supermarket. She tells him that the post office, the supermarket and their home are collinear, and the post office is between the supermarket and their home. Make a map showing the three locations based on this information.

17. **ARCHITECTURE** An architect models the floor, walls, and ceiling of a building with planes. To locate one of the planes that will represent a wall, the architect starts by marking off two points in the plane that represents the floor. What further information can the architect give to specify the plane that will represent the wall?

18. **CONSTRUCTION** Mr. Riley gave his students some rods to represent lines and some clay to show points of intersection. Below is the figure Lynn constructed with all of the points of intersection and some of the lines labeled.

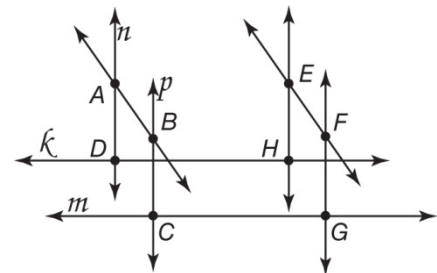

a) What is the intersection of lines k and n ?

b) Name the lines that intersect at point C .

c) Are there 3 points that are collinear and coplanar? If so, name them.

Unlike a line, a **line segment**, or *segment*, can be measured because it has two endpoints.

A segment with endpoints A and B can be named as \overline{AB} is written as AB .

Example 1:

a) Find the length of \overline{AB} using the ruler.

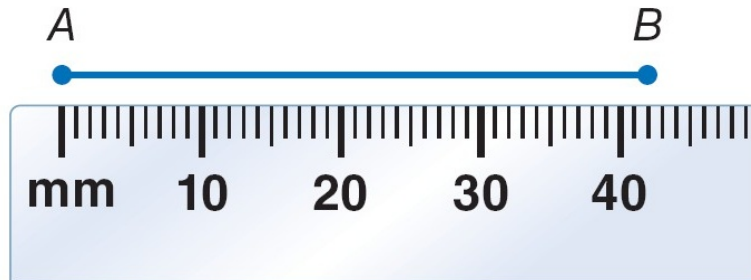

b) Find the length of \overline{AB} using the ruler.

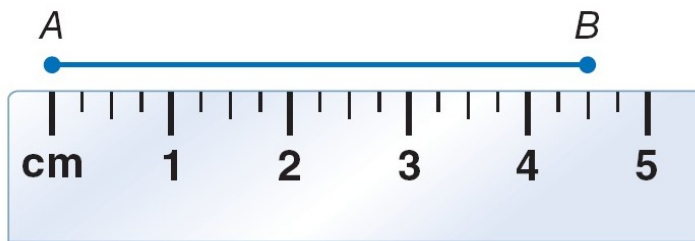

Example 2:

a) Find the length of \overline{DE} .



b) Find the length of \overline{FG} .



Recall that for any two real numbers a and b , there is a real number n that is *between* a and b such that $a < n < b$. This relationship also applies to points on a line and is called **betweenness of points**.



KeyConcept Betweenness of Points

Words

Point M is **between** points P and Q if and only if P , Q , and M are collinear and $PM + MQ = PQ$.

Model

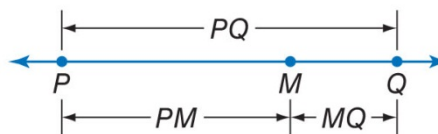

Example 3: Find XZ . Assume that the figure is not drawn to scale.



Example 4: Find LM . Assume that the figure is not drawn to scale.

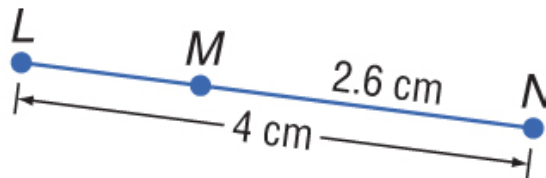

Example 5: Find the value of x and ST if T is between S and U , $ST = 7x$, $SU = 45$, and $TU = 5x - 3$.

KeyConcept Congruent Segments

Words Congruent segments have the same measure.

Symbols \cong is read *is congruent to*. Red slashes on the figure also indicate congruence.

Example $\overline{AB} \cong \overline{CD}$

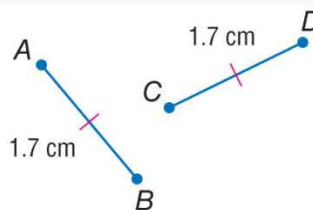

Example 6: The Arial font is often used because it is easy to read. Study the word *time* shown in Arial type. Each letter can be broken into individual segments. The letter T has two segments, a short horizontal segment, and a longer vertical segment. Assume that all segments overlap where they meet. Which segments are congruent?

TIME

Geometry
Section 1.2 Worksheet

Name: _____

For numbers 1 and 2, find the length of each line segment or object.

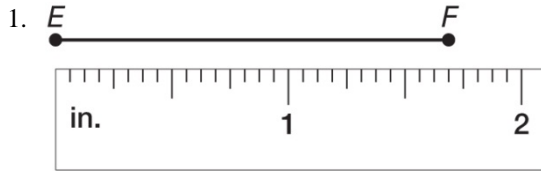

For numbers 3 – 5, find the measurement of each segment. Assume that each figure is not drawn to scale.

3. \overline{PS}

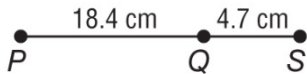

4. \overline{AD}

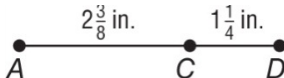

5. \overline{WX}

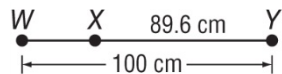

For numbers 6 and 7, find the value of x and KL if K is between J and L .

6. $JK = 6x$, $KL = 3x$, and $JL = 27$

7. $JK = 2x$, $KL = x + 2$, and $JL = 5x - 10$

For numbers 8 – 10, determine whether each pair of segments is congruent.

8. $\overline{TU}, \overline{SW}$

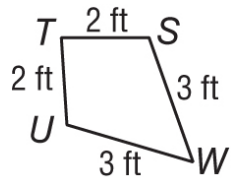

9. $\overline{AD}, \overline{BC}$

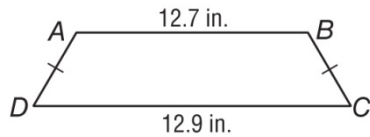

10. $\overline{GF}, \overline{FE}$

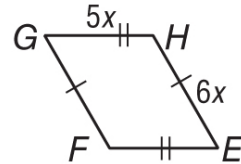

11. **CARPENTRY** Jorge used the figure at the right to make a pattern for a mosaic he plans to inlay on a tabletop. Name all of the congruent segments in the figure.

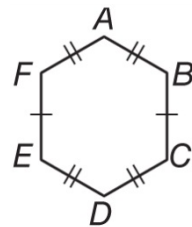

12. **MEASURING** Vera is measuring the size of a small hexagonal silver box that she owns. She places a standard 12 inch ruler alongside the box. About how long is one of the sides of the box?

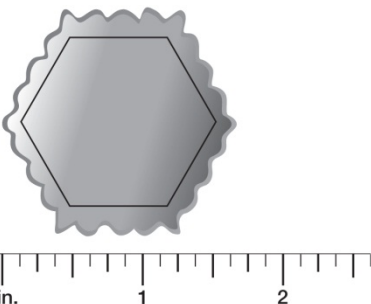

13. **WALKING** Marshall lives 2300 yards from school and 1500 yards from the pharmacy. The school, pharmacy, and his home are all collinear, as shown in the figure. What is the total distance from the pharmacy to the school?

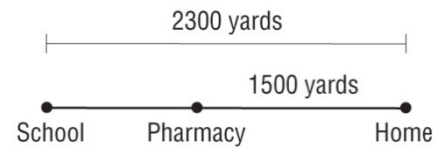

14. **HIKING TRAIL** A hiking trail is 20 kilometers long. Park organizers want to build 5 rest stops for hikers with one on each end of the trail and the other 3 spaced evenly between. How much distance will separate successive rest stops?

15. **RAILROADS** A straight railroad track is being built to connect two cities. The measured distance of the track between the two cities is 160.5 miles. A mailstop is 28.5 miles from the first city. How far is the mailstop from the second city?

16. **BUILDING BLOCKS** Lucy's younger brother has three wooden cylinders. They have heights 8 inches, 4 inches, and 6 inches and can be stacked one on top of the other.

a) If all three cylinders are stacked one on top of the other, how high will the resulting column be? Does it matter in what order the cylinders are stacked?

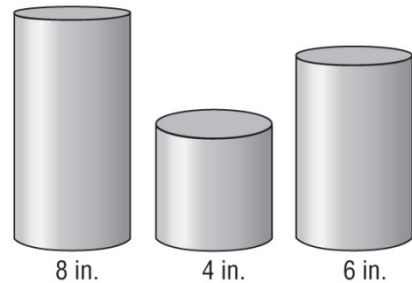

b) What are all the possible heights of columns that can be built by stacking some or all of these cylinders?

Geometry

Section 1.3 Notes: Distance and Midpoints

The **distance** between two points is the length of the segment with those points as its endpoints.

KeyConcept Distance Formula (on Number Line)

Words The distance between two points is the absolute value of the difference between their coordinates.

Symbols If P has coordinate x_1 and Q has coordinate x_2 , $PQ = |x_2 - x_1|$ or $|x_1 - x_2|$.



Example 1: Use the number line to find QR .

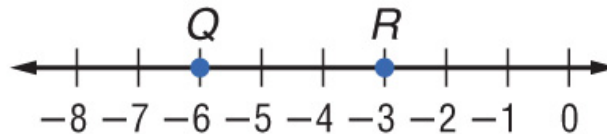

To find the distance between two points A and B in the coordinate plane, you can form a right triangle with \overline{AB} as its hypotenuse and point C as its vertex as shown. Use the Pythagorean Theorem to find AB .

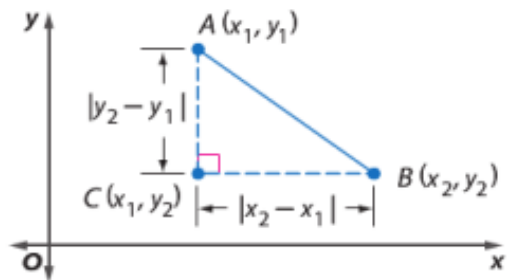

KeyConcept Distance Formula (in Coordinate Plane)

If P has coordinates (x_1, y_1) and Q has coordinates (x_2, y_2) , then

$$PQ = \sqrt{(x_2 - x_1)^2 + (y_2 - y_1)^2}$$

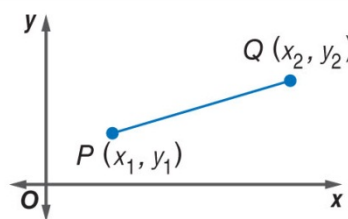

Since the formula for finding the distance between two points involves taking the square root of a real number, distances can be irrational. An **irrational number** is a number that cannot be expressed as a terminating or repeating decimal.

Example 2: Find the distance between $E(-4, 1)$ and $F(3, -1)$.

The **midpoint** of a segment is the point halfway between the endpoints of the segment. If X is the midpoint of \overline{AB} , then $AX = XB$ and $\overline{AX} \cong \overline{XB}$. You can find the midpoint of a segment on a number line by finding the *mean*, or the average of the coordinates of its endpoints.

KeyConcept Midpoint Formula (on Number Line)

If \overline{AB} has endpoints at x_1 and x_2 on a number line, then the midpoint M of \overline{AB} has coordinate

$$\frac{x_1 + x_2}{2}.$$

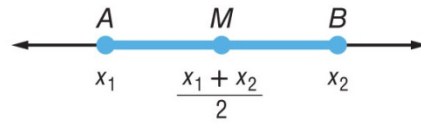

Example 3: Marco places a couch so that its end is perpendicular and 2.5 feet away from the wall. The couch is 90" wide. How far is the midpoint of the couch back from the wall in feet?

KeyConcept Midpoint Formula (in Coordinate Plane)

If \overline{PQ} has endpoints at $P(x_1, y_1)$ and $Q(x_2, y_2)$ in the coordinate plane, then the midpoint M of \overline{PQ} has coordinates

$$M\left(\frac{x_1 + x_2}{2}, \frac{y_1 + y_2}{2}\right).$$

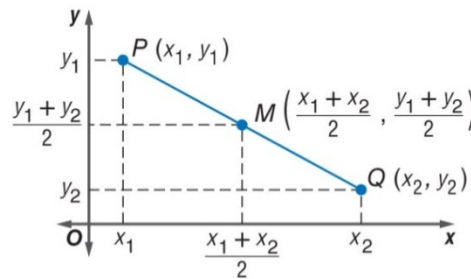

Example 4: Find the coordinates of M , the midpoint of \overline{GH} , for $G(8, -6)$, and $H(-14, 12)$.

Example 5: Find the coordinates of D if $E(-6, 4)$ is the midpoint of \overline{DF} and F has coordinates $(-5, -3)$.

Example 6: What is the measure of \overline{PR} if Q is the midpoint of \overline{PR} ?

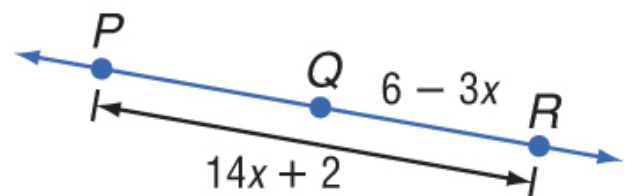

Any segment, line, or plane that intersects a segment is called a **segment bisector**.

In the figure at the right, M is the midpoint of \overline{PQ} . Plane A , \overline{MJ} , \overline{KM} , and point M are all bisectors of \overline{PQ} .

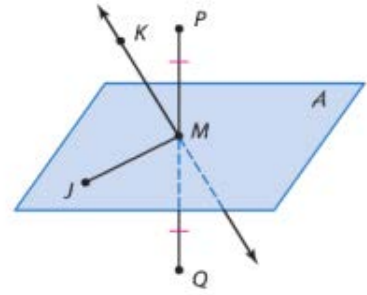

Geometry
Section 1.3 Worksheet

Name: _____

For numbers 1 – 4, use the number line to find each measure.

1. VW

2. TV

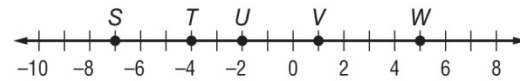

3. ST

4. SV

For numbers 5 – 9, find the distance between each pair of points.

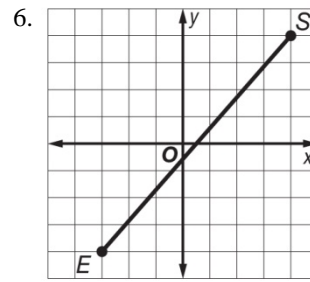
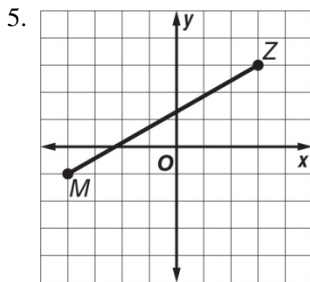

7. $L(-7, 0), Y(5, 9)$

8. $U(1, 3), B(4, 6)$

9. $V(-2, 5), M(0, -4)$

10. $C(-2, -1), K(8, 3)$

For numbers 11 – 14, use the number line to find the coordinate of the midpoint of each segment.

11. \overline{RT}

12. \overline{QR}



13. \overline{ST}

14. \overline{PR}

For numbers 15 and 16, find the coordinates of the midpoint of a segment with the given endpoints.

15. $K(-9, 3), H(5, 7)$

16. $W(-12, -7), T(-8, -4)$

For numbers 17 – 19, find the coordinates of the missing endpoint if E is the midpoint of \overline{DF} .

17. $F(5, 8), E(4, 3)$

18. $F(2, 9), E(-1, 6)$

19. $D(-3, -8), E(1, -2)$

20. **PERIMETER** The coordinates of the vertices of a quadrilateral are $R(-1, 3)$, $S(3, 3)$, $T(5, -1)$, and $U(-2, -1)$. Find the perimeter of the quadrilateral. Round to the nearest tenth.

21. **CAMPGROUND** Troop 175 is designing their new campground by first mapping everything on a coordinate grid. They have found a location for the mess hall and for their cabins. They want the bathrooms to be halfway between these two. What will be the coordinates of the location of the bathrooms?

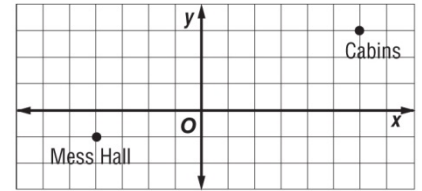

22. **PIZZA** Calvin's home is located at the midpoint between Fast Pizza and Pizza Now. Fast Pizza is a quarter mile away from Calvin's home. How far away is Pizza Now from Calvin's home? How far apart are the two pizzerias?

23. **SPIRALS** Caroline traces out the spiral shown in the figure. The spiral begins at the origin. What is the shortest distance between Caroline's starting point and her ending point?

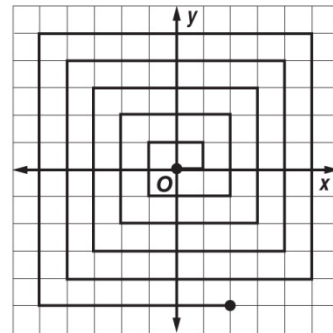

24. **WASHINGTON, D.C.** The United States Capitol is located 800 meters south and 2300 meters to the east of the White House. If the locations were placed on a coordinate grid, the White House would be at the origin. What is the distance between the Capitol and the White House? Round your answer to the nearest meter.

25. **MAPPING** Ben and Kate are making a map of their neighborhood on a piece of graph paper. They decide to make one unit on the graph paper correspond to 100 yards. First, they put their homes on the map as shown below.

a) How many yards apart are Kate's and Ben's homes?

b) Their friend Jason lives exactly halfway between Ben and Kate. Mark the location of Jason's home on the map.

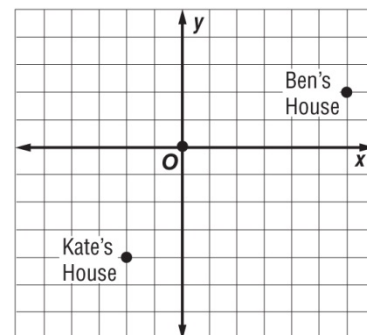

Geometry
Section 1.4 Notes: Angle Measure

A **ray** is a part of a line. It has one endpoint and extends indefinitely in one direction.

Rays are named by stating the endpoint first and then any other point on the ray.

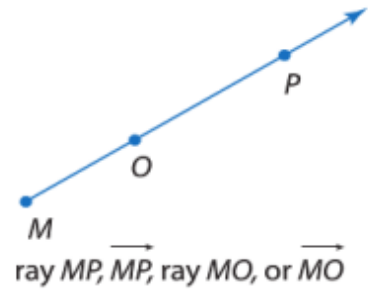

If you choose a point on a line, that point determines exactly two rays called **opposite rays**.

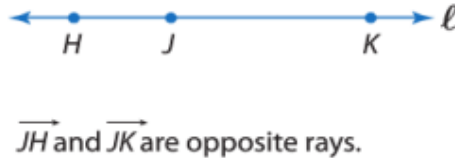

An **angle** is formed by two *noncollinear* rays that have a common endpoint. The rays are called **sides** of the angle. The common endpoint is the **vertex**.

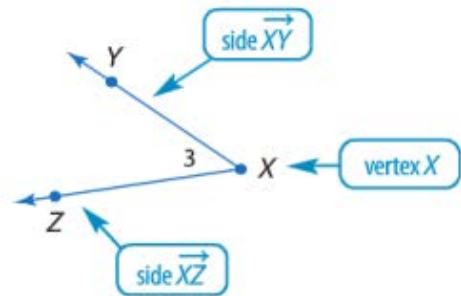

An angle divides a plane into three distinct parts.

*Points Q , M , and N lie on the angle.

*Points S and R lie on the **interior** of the angle.

*Points P and O lie on the **exterior** of the angle.

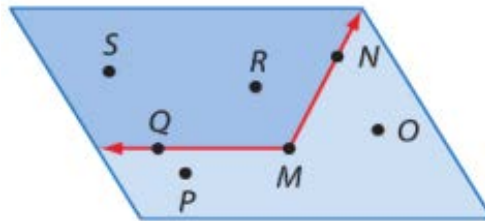

Example 1:

a) Name all angles that have B as a vertex.

b) Name the sides of $\angle 5$.

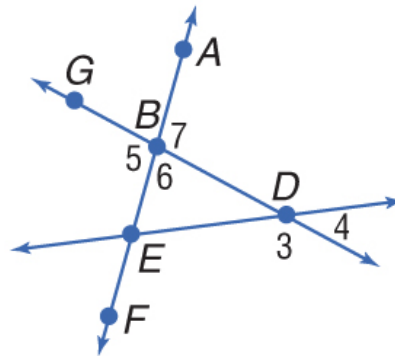

c) Write another name for $\angle 6$.

Angles are measured in units called degrees. The **degree** results from dividing the distance around a circle into 360 parts.

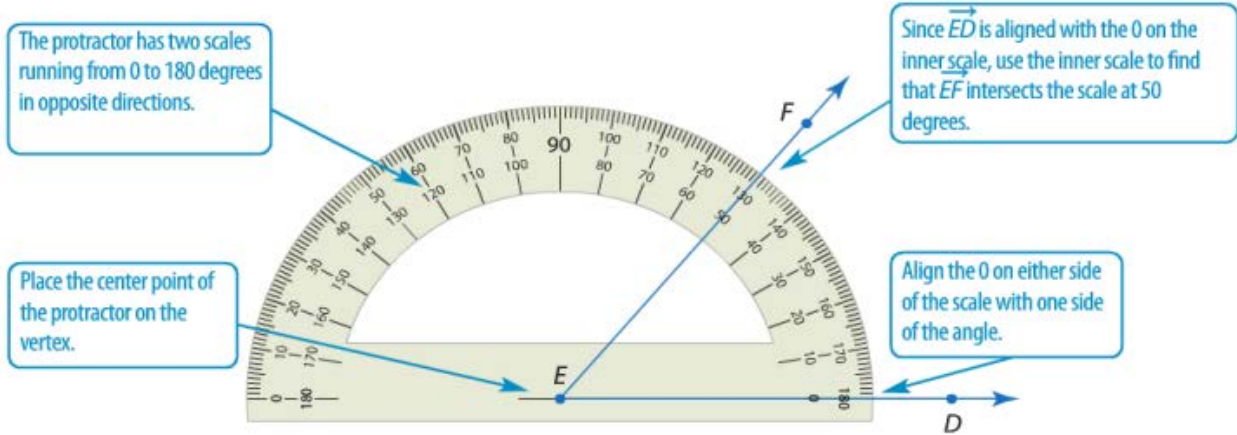
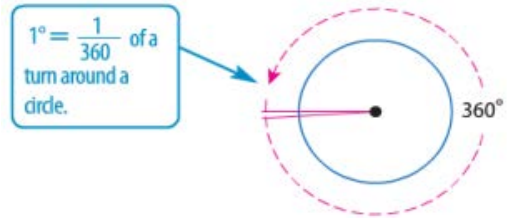

Angles can be classified by their measures.

KeyConcept Classify Angles		
right angle	acute angle	obtuse angle
<p>$m\angle A = 90$</p>	<p>$m\angle B < 90$</p>	<p>$180 > m\angle C > 90$</p>

Example 2:

a) Measure $\angle TYV$ and classify it as *right*, *acute*, or *obtuse*.

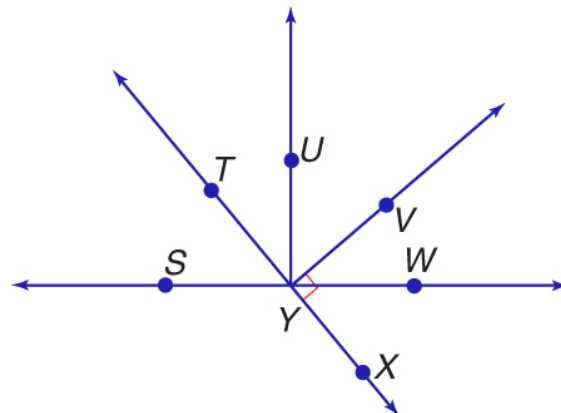

b) Measure $\angle WYT$ and classify it as *right*, *acute*, or *obtuse*.

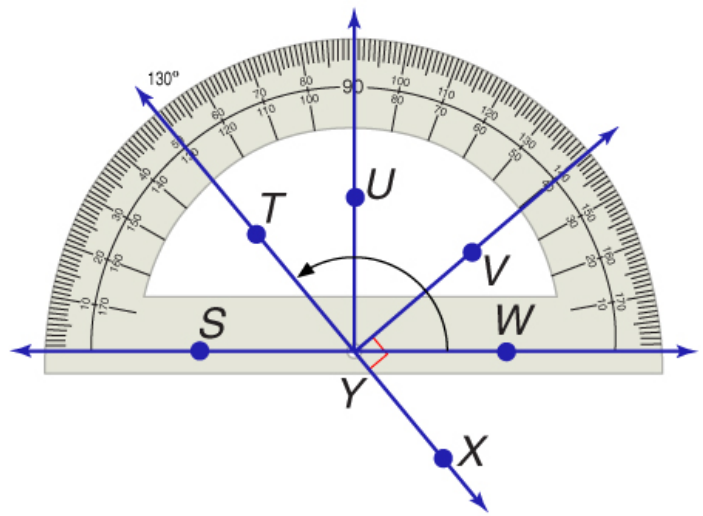

c) Measure $\angle TYU$ and classify it as *right*, *acute*, or *obtuse*.

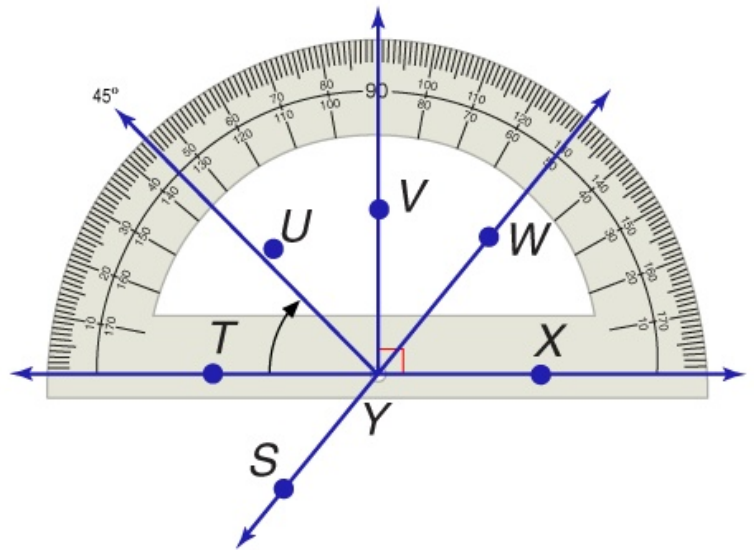

Just as segments that have the same measure are congruent segments, angles that have the same measure are *congruent angles*.

In the figure, since $m\angle ABC = m\angle FED$, then $\angle ABC \cong \angle FED$. Matching numbers of arcs on a figure also indicate congruent angles, so $\angle CBE \cong \angle DEB$.

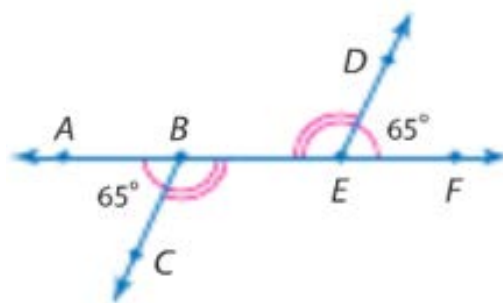

A ray that divides an angle into two congruent angles is called an **angle bisector**. If \overline{YW} is the angle bisector of $\angle XYZ$, then the point W lies in the interior of $\angle XYZ$ and $\angle XYW \cong \angle WYZ$.

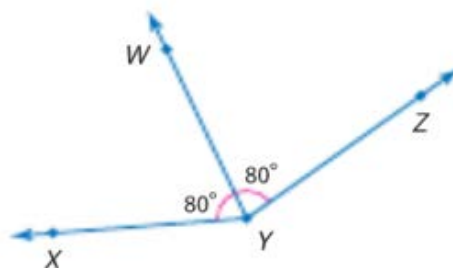

Example 3: Wall stickers of standard shapes are often used to provide a stimulating environment for a young child's room. A five-pointed star sticker is shown with vertices labeled. Find $m\angle GBH$ and $m\angle HCI$ if $\angle GBH \cong \angle HCI$, $m\angle GBH = 2x + 5$, and $m\angle HCI = 3x - 10$.

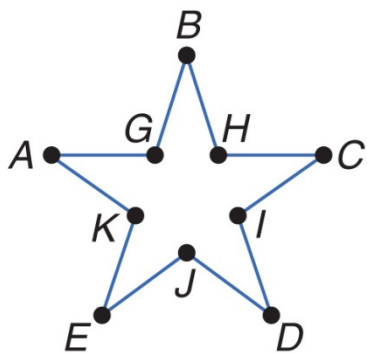

Geometry
Section 1.4 Worksheet

Name: _____

For numbers 1 – 10, use the figure at the right.

For numbers 1 – 4, name the vertex of each angle.

- | | |
|---------------|-----------------|
| 1. $\angle 5$ | 2. $\angle 3$ |
| 3. $\angle 8$ | 4. $\angle NMP$ |

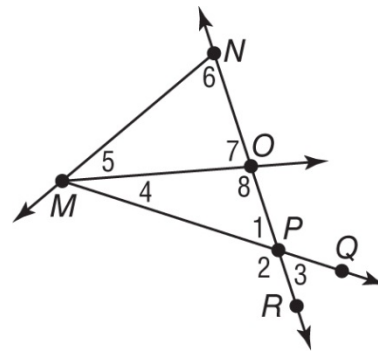

For numbers 5 – 8, name the sides of each angle.

- | | |
|-----------------|-----------------|
| 5. $\angle 6$ | 6. $\angle 2$ |
| 7. $\angle MOP$ | 8. $\angle OMN$ |

For numbers 9 and 10, write another name for each angle.

- | | |
|-----------------|----------------|
| 9. $\angle QPR$ | 10. $\angle 1$ |
|-----------------|----------------|

For numbers 11 – 14, classify each angle as *right*, *acute*, or *obtuse*. Then use a protractor to measure the angle to the nearest degree.

- | | |
|------------------|------------------|
| 11. $\angle UZW$ | 12. $\angle YZW$ |
| 13. $\angle TZW$ | 14. $\angle UZT$ |

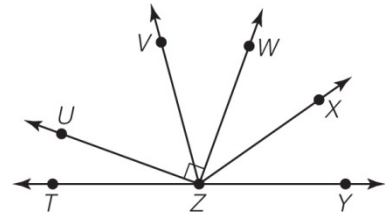

For numbers 15 and 16, in the figure, \overline{CB} and \overline{CD} are opposite rays, \overline{CE} bisects $\angle DCF$, and \overline{CG} bisects $\angle FCB$.

15. If $m\angle DCE = (4x + 15)^\circ$ and $m\angle ECF = (6x - 5)^\circ$, find $m\angle DCE$.

16. If $m\angle FCG = (9x + 3)^\circ$ and $m\angle GCB = (13x - 9)^\circ$, find $m\angle GCB$.

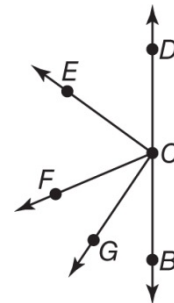

17. **TRAFFIC SIGNS** The diagram shows a sign used to warn drivers of a school zone or crossing. Measure and classify each numbered angle.



18. **LETTERS** Lina learned about types of angles in geometry class. As she was walking home she looked at the letters on a street sign and noticed how many are made up of angles. The sign she looked at was KLINE ST. Which letter(s) on the sign have an obtuse angle? What other letters in the alphabet have an obtuse angle?

19. **SQUARES** A square has four right angle corners. Give an example of another shape that has four right angle corners.

20. **STARS** Melinda wants to know the angle of elevation of a star above the horizon. Based on the figure, what is the angle of elevation? Is this angle an acute, right, or obtuse angle?

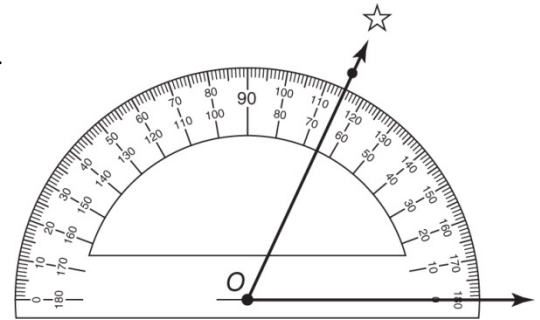

21. **CAKE** Nick has a slice of cake. He wants to cut it in half, bisecting the 46° angle formed by the straight edges of the slice. What will be the measure of the angle of each of the resulting pieces?

22. **ROADS** Central Street runs north-south and Spring Street runs east-west.

a) What kind of angle do Central Street and Spring Street make?

b) Valerie is driving down Spring Street heading east. She takes a left onto River Street. What type of angle did she have to turn her car through?

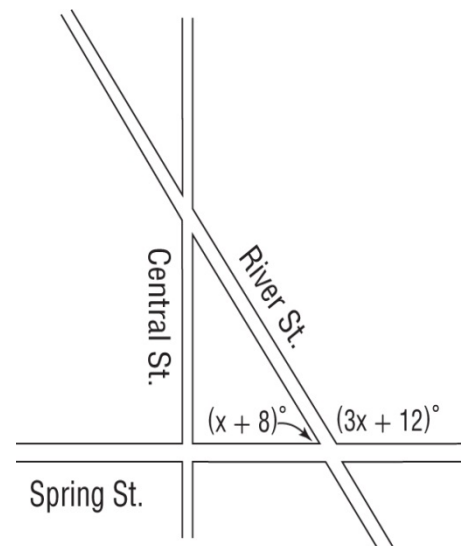

c) What is the angle measure Valerie is turning her car when she takes the left turn?

KeyConcept Special Angle Pairs

Adjacent angles are two angles that lie in the same plane and have a common vertex and a common side, but no common interior points.

Examples $\angle 1$ and $\angle 2$ are adjacent angles.

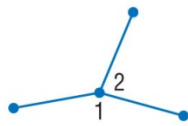
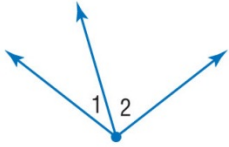

Nonexamples $\angle 3$ and $\angle ABC$ are nonadjacent angles

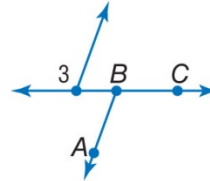
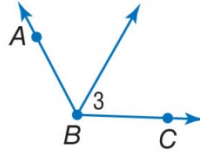

A **linear pair** is a pair of adjacent angles with noncommon sides that are opposite rays.

Example $\angle 1$ and $\angle 2$

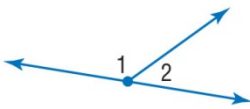

Nonexample $\angle ADB$ and $\angle ADC$

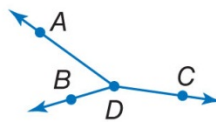

Vertical angles are two nonadjacent angles formed by two intersecting lines.

Examples $\angle 1$ and $\angle 2$; $\angle 3$ and $\angle 4$

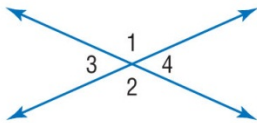

Nonexample $\angle AEB$ and $\angle DEC$

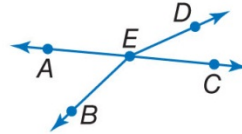

Example 1: ROADWAYS

a) Name an angle pair that satisfies the condition *two angles that form a linear pair*.

b) Name an angle pair that satisfies the condition *two acute vertical angles*.

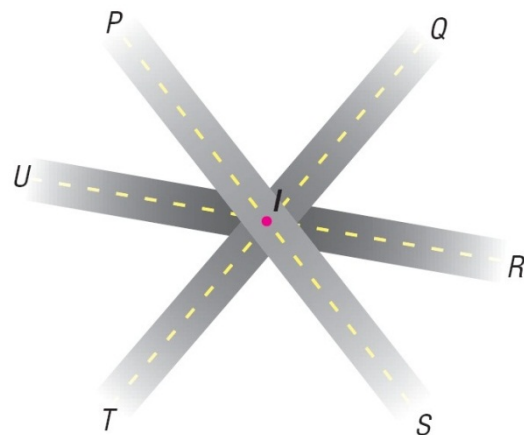

KeyConcept Angle Pair Relationships

Vertical angles are congruent.

Examples $\angle ABC \cong \angle DBE$ and $\angle ABD \cong \angle CBE$

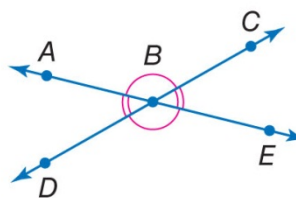

Complementary angles are two angles with measures that have a sum of 90.

Examples $\angle 1$ and $\angle 2$ are complementary.
 $\angle A$ is complementary to $\angle B$.

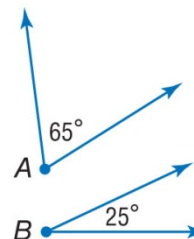
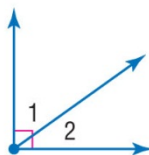

Supplementary angles are two angles with measures that have a sum of 180.

Examples $\angle 3$ and $\angle 4$ are supplementary.
 $\angle P$ and $\angle Q$ are supplementary.

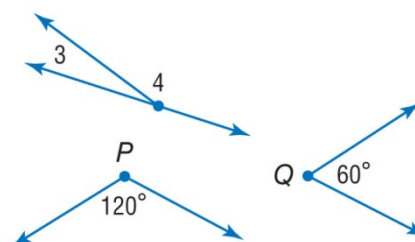

The angles in a linear pair are supplementary.

Example $m\angle 1 + m\angle 2 = 180$

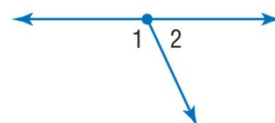

Example 2: Find the measures of two supplementary angles if the measure of one angle is 6 less than five times the measure of the other angle.

KeyConcept Perpendicular Lines

- Perpendicular lines intersect to form four right angles.
- Perpendicular lines intersect to form congruent adjacent angles.
- Segments and rays can be perpendicular to lines or other line segments and rays.
- The right angle symbol in the figure indicates that the lines are perpendicular.

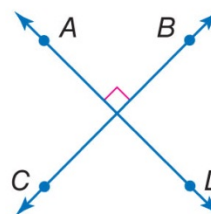

Symbol \perp is read *is perpendicular to*.

Example $\overleftrightarrow{AD} \perp \overleftrightarrow{CB}$

Example 3: Find x and y so that \overline{KO} and \overline{HM} are perpendicular.

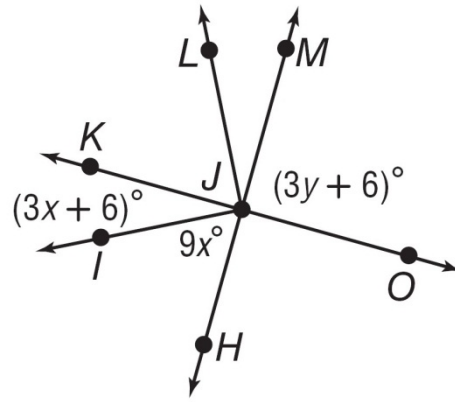

KeyConcept Interpreting Diagrams

CAN be Assumed

All points shown are coplanar.

G , H , and J are collinear.

\overrightarrow{HM} , \overrightarrow{HL} , \overrightarrow{HK} , and \overrightarrow{GJ} intersect at H .

H is between G and J .

L is in the interior of $\angle MHK$.

$\angle GHM$ and $\angle MHL$ are adjacent angles.

$\angle GHL$ and $\angle LHJ$ are a linear pair.

$\angle JHK$ and $\angle KHG$ are supplementary.

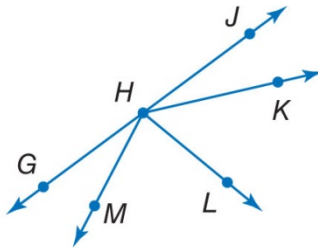

CANNOT be Assumed

Perpendicular lines: $\overrightarrow{HM} \perp \overrightarrow{HL}$

Congruent angles: $\angle JHK \cong \angle GHM$

$\angle JHK \cong \angle KHL$

$\angle KHL \cong \angle LHM$

Congruent segments: $\overline{GH} \cong \overline{HJ}$

$\overline{HJ} \cong \overline{HK}$

$\overline{HK} \cong \overline{HL}$

$\overline{HL} \cong \overline{HG}$

Example 4: Determine whether the following statement can be justified from the figure below. Explain.

a) $m\angle VYT = 90^\circ$

b) $\angle TYW$ and $\angle TYU$ are supplementary.

c) $\angle VYW$ and $\angle TYS$ are adjacent angles.

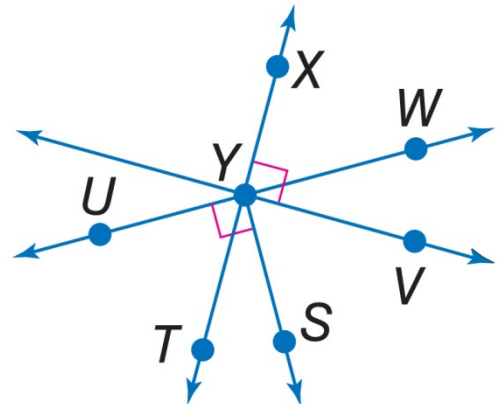

Geometry
Section 1.5 Worksheet

Name: _____

For numbers 1 – 4, name an angle or angle pair that satisfies each condition.

1. Name two obtuse vertical angles.

2. Name a linear pair with vertex B .

3. Name an angle not adjacent to, but complementary to $\angle FGC$.

4. Name an angle adjacent and supplementary to $\angle DCB$.

5. Two angles are complementary. The measure of one angle is 21 more than twice the measure of the other angle. Find the measures of the angles.

6. If a supplement of an angle has a measure 78 less than the measure of the angle, what are the measures of the angles?

For numbers 7 and 8, use the figure at the right.

7. If $m\angle FGE = (5x + 10)^\circ$, find the value of x so that $\overrightarrow{FC} \perp \overrightarrow{AE}$.

8. If $m\angle BGC = (16x - 4)^\circ$ and $m\angle CGD = (2x + 13)^\circ$, find the value of x so that $\angle BGD$ is a right angle.

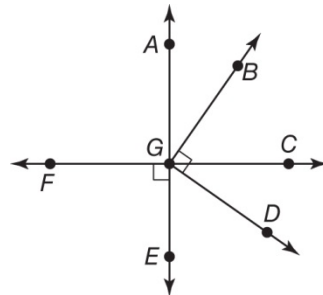

For numbers 9 – 11, determine whether each statement can be assumed from the figure. Explain.

9. $\angle NQO$ and $\angle OQP$ are complementary.

10. $\angle SRQ$ and $\angle QRP$ is a linear pair.

11. $\angle MQN$ and $\angle MQR$ are vertical angles.

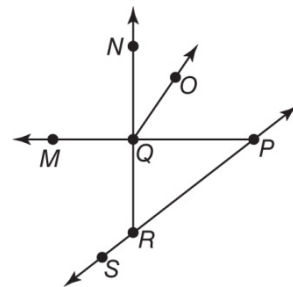

12. **STREET MAPS** Darren sketched a map of the cross streets nearest to his home for his friend Miguel. Describe two different angle relationships between the street

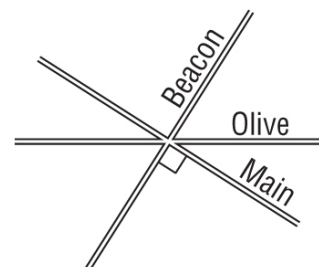

13. **LETTERS** A sign painter is painting a large “X”. What are the measures of angles 1, 2, and 3?

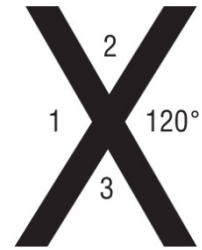

14. **PAPER** Matthew cuts a straight line segment through a rectangular sheet of paper. His cut goes right through a corner. How are the two angles formed at that corner related?

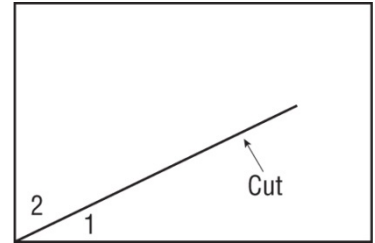

15. **PIZZA** Ralph has sliced a pizza using straight line cuts through the center of the pizza. The slices are not exactly the same size. Ralph notices that two adjacent slices are complementary. If one of the slices has a measure of $(2x)^\circ$, and the other a measure of $(3x)^\circ$, what is the measure of each angle?

16. **GLASS** Carlo dropped a piece of stained glass and the glass shattered. He picked up the piece shown on the left. He wanted to find the piece that was adjoining on the right. What should the measurement of the angle marked with a question mark be? How is that angle related to the angle marked 106° ?

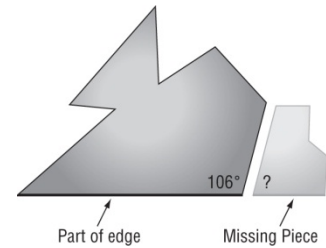

17. **LAYOUTS** A rectangular plaza has a walking path along its perimeter in addition to two paths that cut across the plaza as shown in the figure.

a) Find the measure of $\angle 1$.

b) Find the measure of $\angle 4$.

c) Name a pair of vertical angles in the figure. What is the measure of $\angle 2$?

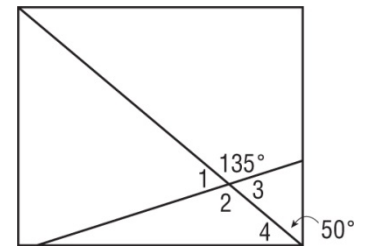

KeyConcept Polygons

A **polygon** is a closed figure formed by a finite number of coplanar segments called *sides* such that

- the sides that have a common endpoint are noncollinear, and
- each side intersects exactly two other sides, but only at their endpoints.

The vertex of each angle is a **vertex of the polygon**.

A polygon is named by the letters of its vertices, written in order of consecutive vertices.

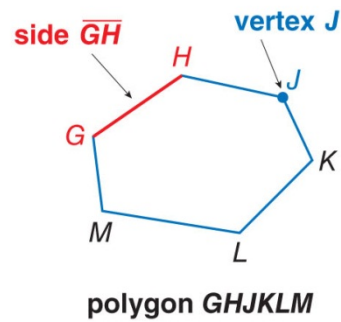

The chart below gives you some additional figures that are polygons and some examples of figures that are not polygons.

Polygons	Not Polygons

Polygons can be **concave** or **convex**. Suppose the line containing each side is drawn. If any of the lines contain any point in the interior of the polygon, then it is concave. Otherwise it is convex.

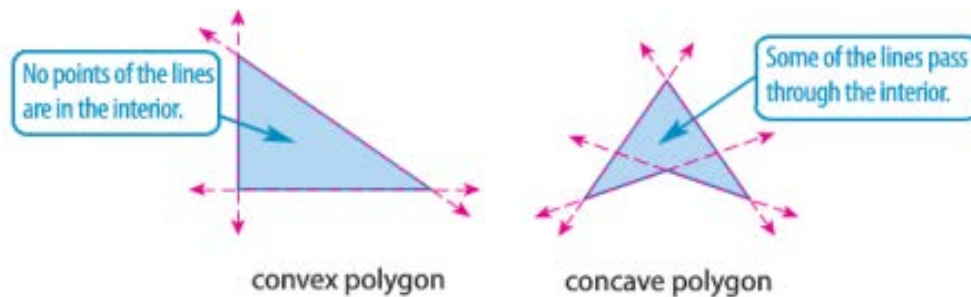

Polygons are generally classified by its number of sides. The table below lists some common names for various categories of polygons. A polygon with n sides is an **n -gon**.

Number of Sides	Polygon
3	Triangle
4	Quadrilateral
5	Pentagon
6	Hexagon
7	Heptagon
8	Octagon
9	Nonagon
10	Decagon
11	Hendecagon
12	Dodecagon
N	n -gon

An **equilateral polygon** is a polygon in which all sides are congruent. An **equiangular polygon** is a polygon in which all angles are congruent.

A convex polygon that is both equilateral and equiangular is called a **regular polygon**.
An *irregular polygon* is a polygon that is *not* regular.

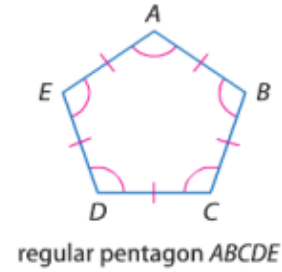

Example 1: Name the polygon by its number of sides. Then classify it as *convex* or *concave* and *regular* or *irregular*.

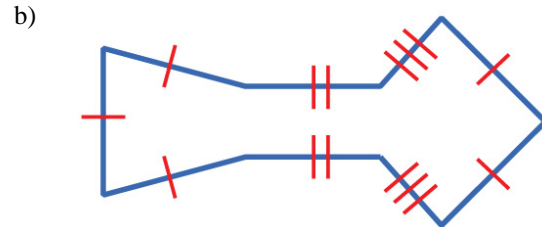
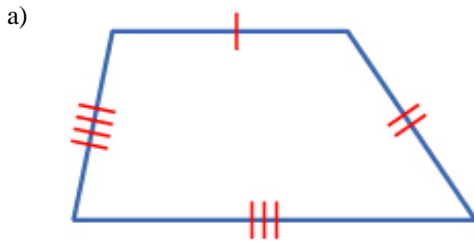

The **perimeter** of a polygon is the sum of the lengths of the sides of the polygon. Some shapes have special formulas for perimeter, but are all derived from the same basic definition of perimeter.

The **circumference** of a circle is the distance around the circle.

The **area** of a figure is the number of square units needed to cover a surface.

KeyConcept Perimeter, Circumference, and Area			
Triangle	Square	Rectangle	Circle
$P = b + c + d$	$P = s + s + s + s$ $= 4s$	$P = l + w + l + w$ $= 2l + 2w$	$C = 2\pi r$ or $C = \pi d$
$A = \frac{1}{2}bh$	$A = s^2$	$A = lw$	$A = \pi r^2$
$P =$ perimeter of polygon $b =$ base, $h =$ height	$A =$ area of figure $l =$ length, $w =$ width		$C =$ circumference $r =$ radius, $d =$ diameter

Example 2:

a) Find the perimeter and area of the figure.

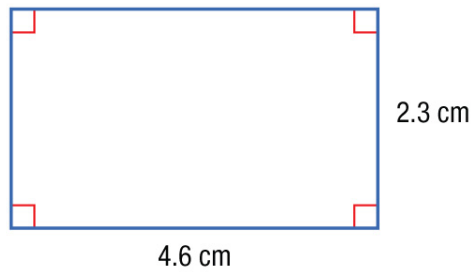

b) Find the circumference and area of the figure.

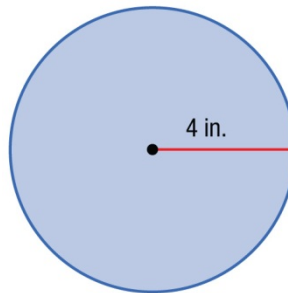

Example 3: Multiple Choice: Terri has 19 feet of tape to mark an area in the classroom where the students may read. Which of these shapes has a perimeter or circumference that would use *most* or all of the tape?

a) square with side length of 5 feet

b) circle with the radius of 3 feet

c) right triangle with each leg length of 6 feet

d) rectangle with a length of 8 feet and a width of 3 feet

Perimeter and Area on the Coordinate Plane

Example 4: Find the perimeter and area of a pentagon $ABCDE$ with $A(0, 4)$, $B(4, 0)$, $C(3, -4)$, $D(-3, -4)$, and $E(-3, 1)$.

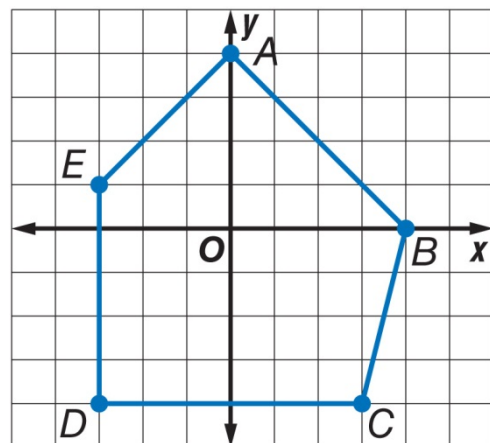

Example 5: Find the perimeter of quadrilateral $WXYZ$ with $W(2, 4)$, $X(-3, 3)$, $Y(-1, 0)$, and $Z(3, -1)$.

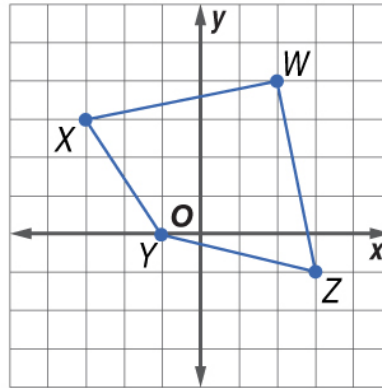

Geometry
Section 1.6 Worksheet

Name: _____

For numbers 1 – 3, name each polygon by its number of sides and then classify it as *convex* or *concave* and *regular* or *irregular*.

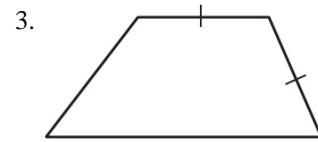
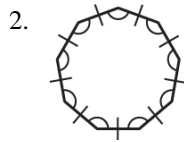
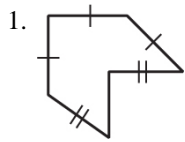

For numbers 4 – 6, find the perimeter or circumference and area of each figure. Round to the nearest tenth.

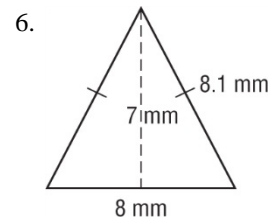
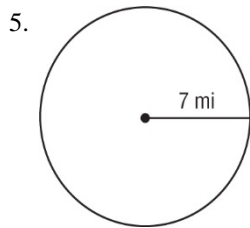
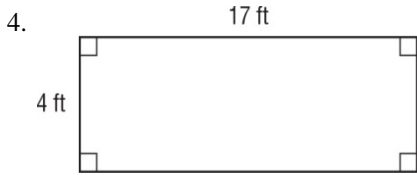

For numbers 7 and 8, graph each figure with the given vertices and identify the figure. Then find the perimeter and area of the figure.

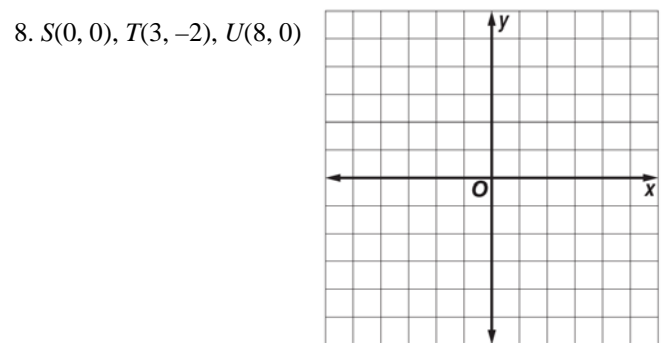
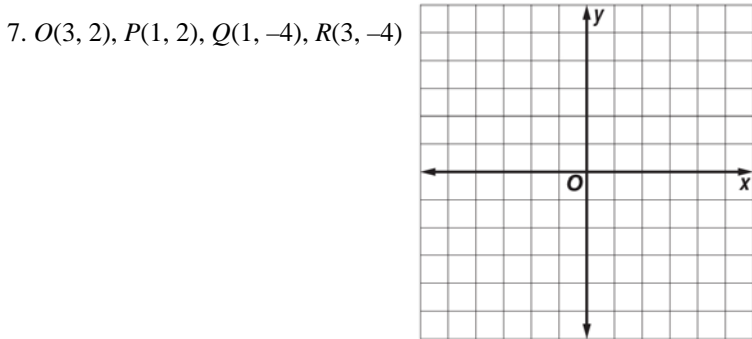

For numbers 9 and 10, use the rectangle from Number 4.

9. Suppose the length and width of the rectangle are doubled. What effect would this have on the perimeter? Justify your answer.

10. Suppose the length and width of the rectangle are doubled. What effect would this have on the area? Justify your answer.

11. **SEWING** Jasmine plans to sew fringe around the circular pillow shown in the diagram.

a) How many inches of fringe does she need to purchase?

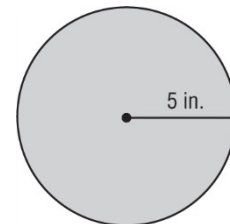

b) If Jasmine doubles the radius of the pillow, what is the new area of the top of the pillow?

12. **ARCHITECTURE** In the Uffizi gallery in Florence, Italy, there is a room filled with paintings by Bronzino called the Tribune room (*La Tribuna* in Italian). The floor plan of the room is shown below. What kind of polygon is the floor plan?

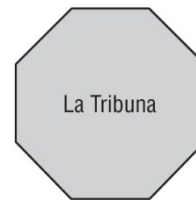

13. **JOGGING** Vassia decides to jog around a city park. The park is shaped like a circle with a diameter of 300 yards. If Vassia makes one loop around the park, approximately how far has she run?

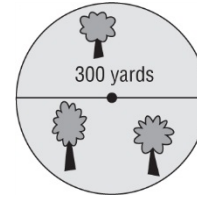

14. **PORTRAITS** Around 1550, Agnolo Bronzino painted a portrait of Eleonore of Toledo and her son. The painting measures 115 centimeters by 96 centimeters. What is the area of the painting?

15. **ORIGAMI** Jane takes a square piece of paper and folds it in half making a crease that connects the midpoints of two opposite sides. The original piece of paper was 8 inches on a side. What is the perimeter of the resulting rectangle?

16. **STICKS** Amy has a box of teriyaki sticks. They are all 15 inches long. She creates rectangles using the sticks by placing them end to end like the rectangle shown in the figure.

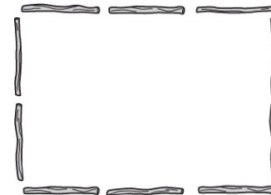



a) How many different rectangles can she make that use exactly 12 of the sticks? What are their dimensions?

b) What is the perimeter of each rectangle listed in part (a)?

c) Which of the rectangles in part (a) has the largest area?

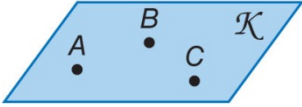
CHAPTER 2

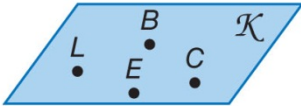
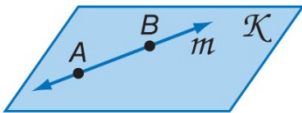
Postulates Points, Lines, and Planes		
Words		Example
2.1 Through any two points, there is exactly one line.		Line n is the only line through points P and R .
2.2 Through any three noncollinear points, there is exactly one plane.		Plane \mathcal{K} is the only plane through noncollinear points A , B , and C .
2.3 A line contains at least two points.		Line n contains points P , Q , and R .
2.4 A plane contains at least three noncollinear points.		Plane \mathcal{K} contains noncollinear points L , B , C , and E .
2.5 If two points lie in a plane, then the entire line containing those points lies in that plane.		Points A and B lie in plane \mathcal{K} , and line m contains points A and B , so line m is in plane \mathcal{K} .

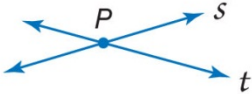
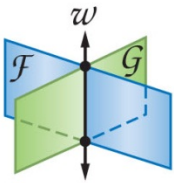
KeyConcept Intersections of Lines and Planes		
Words		Example
2.6 If two lines intersect, then their intersection is exactly one point.		Lines s and t intersect at point P .
2.7 If two planes intersect, then their intersection is a line.		Planes \mathcal{F} and \mathcal{G} intersect in line w .

Example 1: ARCHITECTURE Explain how the picture illustrates that the statement is true. Then state the postulate that can be used to show the statement is true.

a) Points F and G lie in plane Q and on line m . Line m lies entirely in plane Q .

b) Points A and C determine a line.

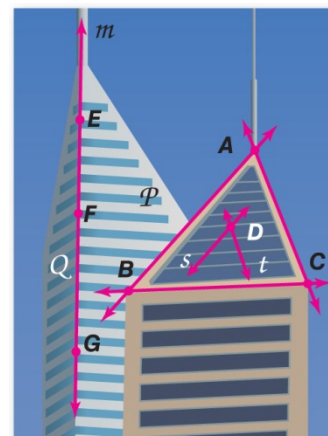

You can use postulates to explain your reasoning when analyzing statements.

Example 2: Determine whether the following statement is *always*, *sometimes*, or *never* true. Explain.

a) If plane T contains \overleftrightarrow{EF} and \overleftrightarrow{EF} contains point G , then plane T contains point G .

b) \overleftrightarrow{GH} contains three noncollinear points.

To prove a conjecture, you use deductive reasoning to move from a hypothesis to the conclusion of the conjecture you are trying to prove. This is done by writing a **proof**, which is a logical argument in which each statement you make is supported by a statement that is accepted as true.

Once a statement or conjecture has been proven, it is called a **theorem**, and it can be used as a reason to justify statements in other proofs.

KeyConcept The Proof Process

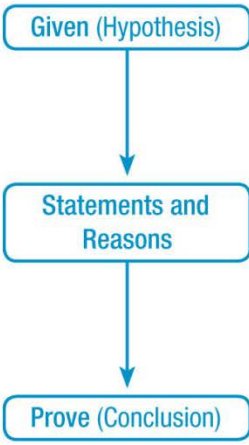
<p>Step 1 List the given information and, if possible, draw a diagram to illustrate this information.</p> <p>Step 2 State the theorem or conjecture to be proven.</p> <p>Step 3 Create a deductive argument by forming a logical chain of statements linking the given to what you are trying to prove.</p> <p>Step 4 Justify each statement with a reason. Reasons include definitions, algebraic properties, postulates, and theorems.</p> <p>Step 5 State what it is that you have proven.</p>	 <pre>graph TD; A[Given (Hypothesis)] --> B[Statements and Reasons]; B --> C[Prove (Conclusion)];</pre>
---------------------------------------------------------------------------------------------------------------------------------------------------------------------------------------------------------------------------------------------------------------------------------------------------------------------------------------------------------------------------------------------------------------------------------------------------------------------------------------------------------------------------------------------	--------------------------------------------------------------------------------------------------------------------------------------------------------------------------------------------------

One method of proving statements and conjectures, a **paragraph proof**, involves writing a paragraph to explain why a conjecture for a given situation is true. Paragraph proofs are also called **informal proofs**, although the term *informal* is not meant to imply that this form of proof is any less valid than any other type of proof.

Example 3: Given \overleftrightarrow{AC} intersects \overleftrightarrow{CD} , write a paragraph proof to show that A , C , and D determine a plane.

The conjecture in Example 3 is known as the Midpoint Theorem.

Theorem 2.1 Midpoint Theorem

If M is the midpoint of \overline{AB} , then $\overline{AM} \cong \overline{MB}$.



For numbers 1 and 2, explain how the figure illustrates that each statement is true. Then state the postulate that can be used to show each statement is true.

1. The planes J and K intersect at line m .

2. The lines l and m intersect at point Q .

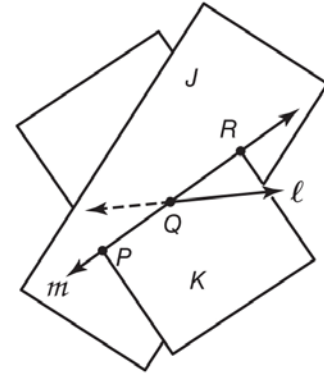

For numbers 3 and 4, determine whether the following statements are *always*, *sometimes*, or *never* true. Explain.

3. The intersection of two planes contains at least two points.

4. If three planes have a point in common, then they have a whole line in common.

For numbers 5 and 6, state the postulate that can be used to show that each statement is true. In the figure, line m and \overline{TQ} lie in plane \mathcal{A} .

5. Points L , and T and line m lie in the same plane.

6. Line m and \overline{ST} intersect at T .

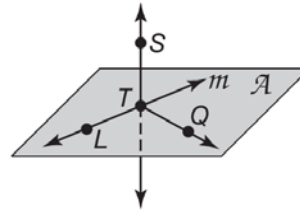

7. In the figure, E is the midpoint of \overline{AB} and \overline{CD} , and $AB = CD$. Write a paragraph proof to prove that $\overline{AE} \cong \overline{ED}$.

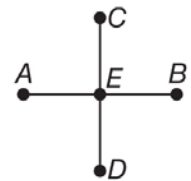

8. **ROOFING** Noel and Kirk are building a new roof. They wanted a roof with two sloping planes that meet along a curved arch. Is this possible?

9. **AIRLINES** An airline company wants to provide service to San Francisco, Los Angeles, Chicago, Dallas, Washington D.C., and New York City. The company's CEO draws lines between each pair of cities in the list on a map. No three of the cities are collinear. How many lines did the CEO draw?

10. **TRIANGULATION** A sailor spots a whale through her binoculars. She wonders how far away the whale is, but the whale does not show up on the radar system. She sees another boat in the distance and radios the captain asking him to spot the whale and record its direction. Explain how this added information could enable the sailor to pinpoint the location of the whale. Under what circumstance would this idea fail?

11. **POINTS** Carson claims that a line can intersect a plane at only one point and draws this picture to show his reasoning. Zoe thinks it is possible for a line to intersect a plane at more than one point. Who is correct? Explain.

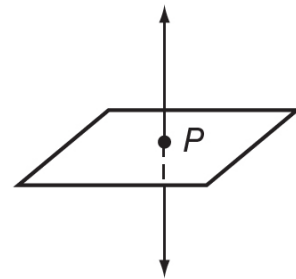

12. **FRIENDSHIPS** A small company has 16 employees. The owner of the company became concerned that the employees did not know each other very well. He decided to make a picture of the friendships in the company. He placed 16 points on a sheet of paper in such a way that no 3 were collinear. Each point represented a different employee. He then asked each employee who their friends were and connected two points with a line segment if they represented friends.

a) What is the maximum number of line segments that can be drawn between pairs among the 16 points?

b) When the owner finished the picture, he found that his company was split into two groups, one with 10 people and the other with 6. The people within a group were all friends, but nobody from one group was a friend of anybody from the other group. How many line segments were there?

KeyConcept Properties of Real Numbers	
The following properties are true for any real numbers a , b , and c .	
Addition Property of Equality	If $a = b$, then $a + c = b + c$.
Subtraction Property of Equality	If $a = b$, then $a - c = b - c$.
Multiplication Property of Equality	If $a = b$, then $a \cdot c = b \cdot c$.
Division Property of Equality	If $a = b$ and $c \neq 0$, then, $\frac{a}{c} = \frac{b}{c}$.
Reflexive Property of Equality	$a = a$
Symmetric Property of Equality	If $a = b$, then $b = a$.
Transitive Property of Equality	If $a = b$ and $b = c$, then $a = c$.
Substitution Property of Equality	If $a = b$, then a may be replaced by b in any equation or expression.
Distributive Property	$a(b + c) = ab + ac$

An **algebraic proof** is a proof that is made up of a series of algebraic statements. The properties of equality provide justification for many statements in algebraic proofs.

Example 1: Justify each step when solving an equation.

a) Solve $2(5 - 3a) - 4(a + 7) = 92$.

b) Solve $-3(a + 3) + 5(3 - a) = -50$.

In geometry, a similar format is used to prove conjectures and theorems. A **two-column proof** or **formal proof** contains statements and reasons organized in two columns.

Example 2:

a) **SCIENCE** If the distance d an object travels is given by $d = 20t + 5$, the time t that the object travels is given by $t = \frac{d - 5}{20}$.

Write a two-column proof to verify this conjecture.

Begin by stating what is given and what you are to prove.

Given: $d = 20t + 5$

Prove: $t = \frac{d - 5}{20}$

Statements	Reasons
1. $d = 20t + 5$	1. Given
2. $d - 5 = 20t$	2.
3. $\frac{d-5}{20} = t$	3.
4. $t = \frac{d-5}{20}$	4.

b) Which of the following statements would complete the proof of this conjecture?

If the formula for the area of a trapezoid is $A = \frac{1}{2}(b_1 + b_2)h$, then the height h of the trapezoid is given by $h = \frac{2A}{(b_1 + b_2)}$.

Given: $A = \frac{1}{2}(b_1 + b_2)h$

Prove: $h = \frac{2A}{(b_1 + b_2)}$

Statements	Reasons
1. $A = \frac{1}{2}(b_1 + b_2)h$	1. Given
2.	2. Multiplication Property of Equality
3. $\frac{2A}{(b_1 + b_2)} = h$	3. Division Property of Equality
4. $h = \frac{2A}{(b_1 + b_2)}$	4. Symmetric Property of Equality

Example 3: Write a Geometric Proof

If $\angle A \cong \angle B$, $m\angle B = 2(m\angle C)$, and $m\angle C = 45^\circ$, then $m\angle A = 90^\circ$. Write a two-column proof to verify this conjecture.

Given: $\angle A \cong \angle B$, $m\angle B = 2(m\angle C)$,

$m\angle C = 45^\circ$

Prove: $m\angle A = 90^\circ$

Statements	Reasons
1. $\angle A \cong \angle B$, $m\angle B = 2(m\angle C)$, $m\angle C = 45^\circ$	1. Given
2. $m\angle A = m\angle B$	2.
3. $m\angle A = 2(m\angle C)$	3.
4. $m\angle A = 2(45)$	4.
5. $m\angle A = 90^\circ$	5.

State the property that justifies each statement.

1. If $80 = m\angle A$, then $m\angle A = 80$.
2. If $RS = TU$ and $TU = YP$, then $RS = YP$.
3. If $7x = 28$, then $x = 4$.
4. If $VR + TY = EN + TY$, then $VR = EN$.
5. If $m\angle 1 = 30$ and $m\angle 1 = m\angle 2$, then $m\angle 2 = 30$.

Complete the following proof.

6. Given: $8x - 5 = 2x + 1$

Prove: $x = 1$

Proof:

Statements	Reasons
a. $8x - 5 = 2x + 1$	a. _____
b. $8x - 5 - 2x = 2x + 1 - 2x$	b. _____
c. _____	c. Substitution Property
d. _____	d. Addition Property
e. $6x = 6$	e. _____
f. $\frac{6x}{6} = \frac{6}{6}$	f. _____
g. _____	g. _____

Write a two-column proof to verify the conjecture.

7. If $\overline{PQ} \cong \overline{QS}$ and $\overline{QS} \cong \overline{ST}$ then $PQ = ST$.



(There is a backside)

- 8. DOGS** Jessica and Robert each own the same number of dogs. Robert and Gail also own the same number of dogs. Without knowing how many dogs they own, one can still conclude that Jessica and Gail each own the same number of dogs. What property is used to make this conclusion?
- 9. MONEY** Lars and Peter each have the same amount of money in their wallets. They went to the store together and decided to buy some cookies, splitting the cost equally. After buying the cookies, do they still have the same amount of money in their wallets? What property is relevant to help you decide?
- 10. MANUFACTURING** A company manufactures small electronic components called diodes. Each diode is worth \$1.50. Plant A produced 4443 diodes and Plant B produced 5557 diodes. The supervisor was asked what the total value of all the diodes was. The supervisor immediately responded "\$15,000." The supervisor would not have been able to compute the value so quickly if he had to multiply \$1.50 by 4443 and then add this to the result of \$1.50 times 5557. Explain how you think the supervisor got the answer so quickly?
- 11. FIGURINES** Pete and Rhonda paint figurines. They can both paint 8 figurines per hour. One day, Pete worked 6 hours while Rhonda worked 9 hours. How many figurines did they paint that day? Show how to get the answer using the Distributive Property.
- 12. AGE** William's father is eight years older than 4 times William's age. William's father is 36 years old.
- a.** Let x be William's age. Translate the given information into an algebraic equation involving x .

Postulate 2.8 Ruler Postulate

Words The points on any line or line segment can be put into one-to-one correspondence with real numbers.
Symbols Given any two points A and B on a line, if A corresponds to zero, then B corresponds to a positive real number.

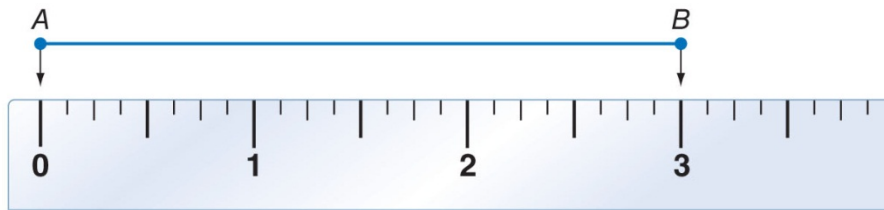

Postulate 2.9 Segment Addition Postulate

Words If A , B , and C are collinear, then point B is between A and C if and only if $AB + BC = AC$.
Symbols

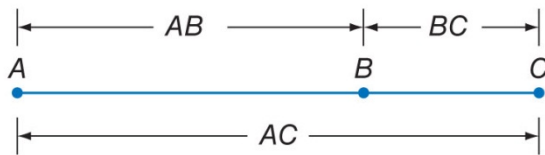

Example 2: Prove that if $\overline{AB} \cong \overline{CD}$, then $\overline{AC} \cong \overline{BD}$.

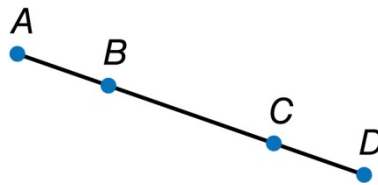

Statements	Reasons
1.	1.
2.	2.
3.	3.
4.	4.
5.	5.
6.	6.
7.	7.
8.	8.

Example 3: Prove the following

Given: $AC = AB$

$AB = BX$

$CY = XD$

Prove: $AY = BD$

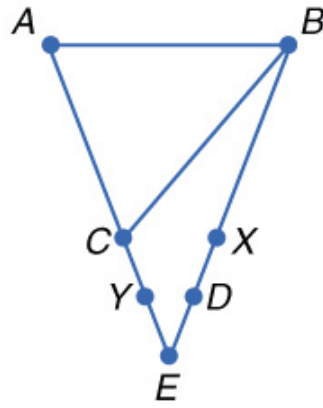

Statements	Reasons
1.	1.
2.	2.
3.	3.
4.	4.
5.	5.
6.	6.
7.	7.
8.	8.

Theorem 2.2 Properties of Segment Congruence

Reflexive Property of Congruence

$$\overline{AB} \cong \overline{AB}$$

Symmetric Property of Congruence

If $\overline{AB} \cong \overline{CD}$, then $\overline{CD} \cong \overline{AB}$.

Transitive Property of Congruence

If $\overline{AB} \cong \overline{CD}$ and $\overline{CD} \cong \overline{EF}$, then $\overline{AB} \cong \overline{EF}$.

Example 4: BADGE Jamie is designing a badge for her club. The length of the top edge of the badge is equal to the length of the left edge of the badge. The top edge of the badge is congruent to the right edge of the badge, and the right edge of the badge is congruent to the bottom edge of the badge. Prove that the bottom edge of the badge is congruent to the left edge of the badge.

Given: $WY = YZ$

$$\overline{YZ} \cong \overline{XZ}$$

$$\overline{XZ} \cong \overline{WX}$$

Prove: $\overline{WX} \cong \overline{WY}$

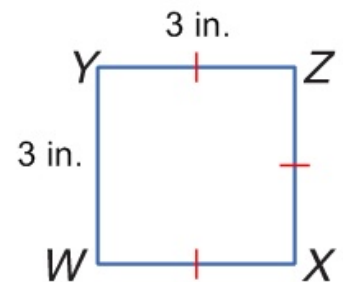

Statements	Reasons
1.	1.
2.	2.
3.	3.
4.	4.
5.	5.
6.	6.

Example 5: Prove the following.

Given: $\overline{GD} \cong \overline{BC}$

$\overline{BC} \cong \overline{FH}$

$\overline{FH} \cong \overline{AE}$

Prove: $\overline{AE} \cong \overline{GD}$

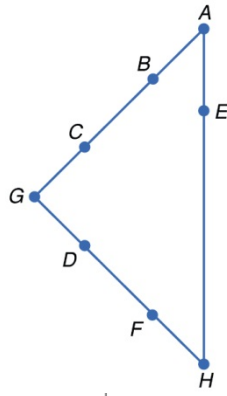

Statements	Reasons
1.	1.
2.	2.
3.	3.
4.	4.
5.	5.
6.	6.

1. Given: $\overline{AB} \cong \overline{DE}$

B is the midpoint of \overline{AC} .

E is the midpoint of \overline{DF} .

Prove: $\overline{BC} \cong \overline{EF}$

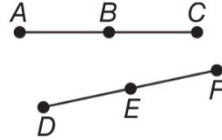

Statements	Reasons
1.	1. Given
2. $AB = DE$	2.
3. B is the midpoint of \overline{AC} .	3.
4.	4. Definition of Midpoint
5. E is the midpoint of \overline{DF} .	5.
6.	6. Definition of Midpoint
7. $BC = DE$	7.
8. $BC = EF$	8.
9.	9.

2. **TRAVEL** Refer to the figure. DeAnne knows that the distance from Grayson to Apex is the same as the distance from Redding to Pine Bluff. Prove that the distance from Grayson to Redding is equal to the distance from Apex to Pine Bluff.



3. **FAMILY** Maria is 11 inches shorter than her sister Nancy. Brad is 11 inches shorter than his brother Chad. If Maria is shorter than Brad, how do the heights of Nancy and Chad compare? What if Maria and Brad are the same height?

4. **DISTANCE** Martha and Laura live 1400 meters apart. A library is opened between them and is 500 meters from Martha. How far is the library from Laura?

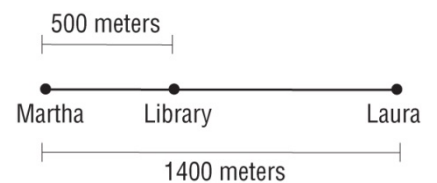

5. **LUMBER** Byron works in a lumber yard. His boss just cut a dozen planks and asked Byron to double check that they are all the same length. The planks were numbered 1 through 12. Byron took out plank number 1 and checked that the other planks are all the same length as plank 1. He concluded that they must all be the same length. Explain how you know plank 7 and plank 10 are the same length even though they were never directly compared to each other?

6. **NEIGHBORHOODS** Karla, John, and Mandy live in three houses that are on the same line. John lives between Karla and Mandy. Karla and Mandy live a mile apart. Is it possible for John to be a mile from both Karla and Mandy?

7. **LIGHTS** Five lights, A , B , C , D , and E , are lined up in a row. The middle light is the midpoint of the second and fourth light and also the midpoint of the first and last light.

a) Draw a figure to illustrate the situation.

b) Complete this proof.

Given: C is the midpoint of \overline{BD} and \overline{AE} .

Prove: $AB = DE$

Statement	Reason
1. C is the midpoint of \overline{BD} and \overline{AE} .	1. Given
2. $BC = CD$ and _____	2.
3. $AC = AB + BC$, $CE = CD + DE$	3.
4. $AB = AC - BC$	4.
5.	5. Substitution Property
6. $DE = CE - CD$	6.
7.	7.

Postulate 2.10 Protractor Postulate

Words Given any angle, the measure can be put into one-to-one correspondence with real numbers between 0 and 180.

Example If \overrightarrow{BA} is placed along the protractor at 0° , then the measure of $\angle ABC$ corresponds to a positive real number.

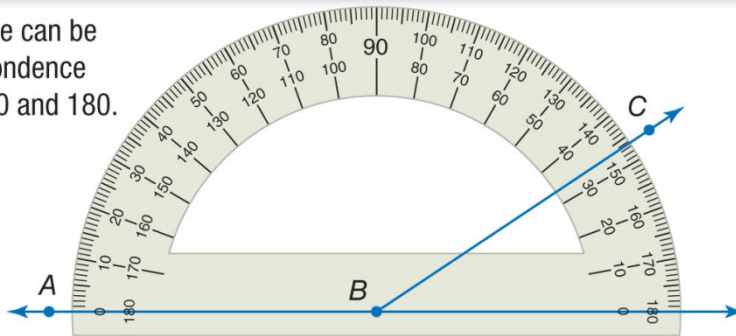

Postulate 2.11 Angle Addition Postulate

D is in the interior of $\angle ABC$ if and only if
 $m\angle ABD + m\angle DBC = m\angle ABC$.

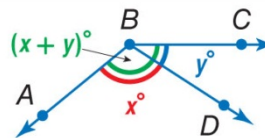

Example 1: CONSTRUCTION Using a protractor, a construction worker measures that the angle a beam makes with a ceiling is 42° . What is the measure of the angle the beam makes with the wall?

Theorems

2.3 Supplement Theorem If two angles form a linear pair, then they are supplementary angles.

Example $m\angle 1 + m\angle 2 = 180$

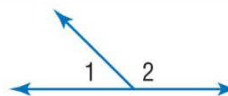

2.4 Complement Theorem If the noncommon sides of two adjacent angles form a right angle, then the angles are complementary angles.

Example $m\angle 1 + m\angle 2 = 90$

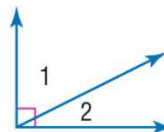

Example 2: TIME At 4 o'clock, the angle between the hour and minute hands of a clock is 120° . When the second hand bisects the angle between the hour and minute hands, what are the measures of the angles between the minute and second hands and between the second and hour hands?

Theorem 2.5 Properties of Angle Congruence

Reflexive Property of Congruence

$$\angle 1 \cong \angle 1$$

Symmetric Property of Congruence

If $\angle 1 \cong \angle 2$, then $\angle 2 \cong \angle 1$.

Transitive Property of Congruence

If $\angle 1 \cong \angle 2$ and $\angle 2 \cong \angle 3$, then $\angle 1 \cong \angle 3$.

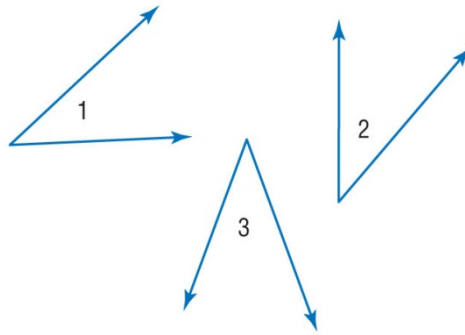

Theorems

2.6 Congruent Supplements Theorem

Angles supplementary to the same angle or to congruent angles are congruent.

Abbreviation \sphericalangle *suppl. to same \sphericalangle or $\cong \sphericalangle$ are \cong .*

Example If $m\angle 1 + m\angle 2 = 180$ and $m\angle 2 + m\angle 3 = 180$, then $\angle 1 \cong \angle 3$.

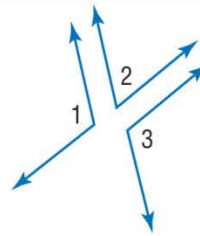

2.7 Congruent Complements Theorem

Angles complementary to the same angle or to congruent angles are congruent.

Abbreviation \sphericalangle *compl. to same \sphericalangle or $\cong \sphericalangle$ are \cong .*

Example If $m\angle 4 + m\angle 5 = 90$ and $m\angle 5 + m\angle 6 = 90$, then $\angle 4 \cong \angle 6$.

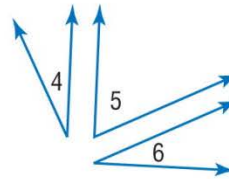

Example 3: In the figure, $\angle 1$ and $\angle 4$ form a linear pair, and $m\angle 3 + m\angle 1 = 180^\circ$. Prove that $\angle 3$ and $\angle 4$ are congruent.

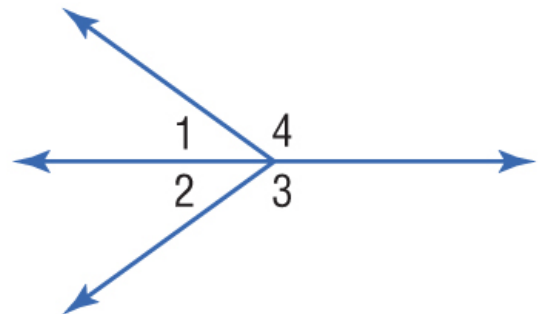

Statements	Reasons
1.	1.
2.	2.
3.	3.
4.	4.
5.	5.

Theorem 2.8 Vertical Angles Theorem

If two angles are vertical angles, then they are congruent.

Abbreviation *Vert. \sphericalangle are \cong .*

Example $\angle 1 \cong \angle 3$ and $\angle 2 \cong \angle 4$

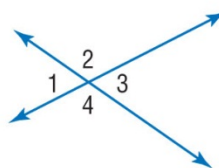

Example 4: If $\angle 1$ and $\angle 2$ are vertical angles and $m\angle 1 = (d - 32)^\circ$ and $m\angle 2 = (175 - 2d)^\circ$, find $m\angle 1$ and $m\angle 2$. Justify each step.

Statements	Reasons
1.	1.
2.	2.
3.	3.
4.	4.
5.	5.
6.	6.
7.	7.
8.	8.

Theorems Right Angle Theorems

Theorem	Example
<p>2.9 Perpendicular lines intersect to form four right angles.</p> <p>Example If $\overrightarrow{AC} \perp \overrightarrow{DB}$, then $\angle 1, \angle 2, \angle 3,$ and $\angle 4$ are rt. \sphericalangle.</p>	
<p>2.10 All right angles are congruent.</p> <p>Example If $\angle 1, \angle 2, \angle 3,$ and $\angle 4$ are rt. \sphericalangle, then $\angle 1 \cong \angle 2 \cong \angle 3 \cong \angle 4$.</p>	
<p>2.11 Perpendicular lines form congruent adjacent angles.</p> <p>Example If $\overrightarrow{AC} \perp \overrightarrow{DB}$, then $\angle 1 \cong \angle 2, \angle 2 \cong \angle 4, \angle 3 \cong \angle 4,$ and $\angle 1 \cong \angle 3$.</p>	
<p>2.12 If two angles are congruent and supplementary, then each angle is a right angle.</p> <p>Example If $\angle 5 \cong \angle 6$ and $\angle 5$ is suppl. to $\angle 6$, then $\angle 5$ and $\angle 6$ are rt. \sphericalangle.</p>	
<p>2.13 If two congruent angles form a linear pair, then they are right angles.</p> <p>Example If $\angle 7$ and $\angle 8$ form a linear pair, then $\angle 7$ and $\angle 8$ are rt. \sphericalangle.</p>	

For numbers 1 – 3, find the measure of each numbered angle and name the theorems that justify your work.

1. $m\angle 1 = (x + 10)^\circ$
 $m\angle 2 = (3x + 18)^\circ$

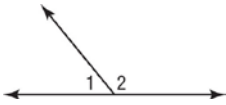

2. $m\angle 4 = (2x - 5)^\circ$
 $m\angle 5 = (4x - 13)^\circ$

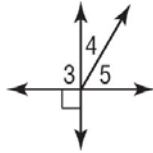

3. $m\angle 6 = (7x - 24)^\circ$
 $m\angle 7 = (5x + 14)^\circ$

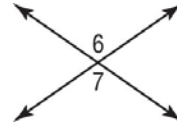

4. Write a two-column proof.

Given: $\angle 1$ and $\angle 2$ form a linear pair.
 $\angle 2$ and $\angle 3$ are supplementary.

Prove: $\angle 1 \cong \angle 3$

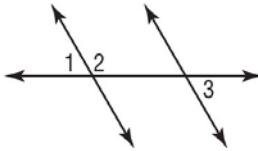

5. **STREETS** Refer to the figure. Barton Road and Olive Tree Lane form a right angle at their intersection. Tryon Street forms a 57° angle with Olive Tree Lane. What is the measure of the acute angle Tryon Street forms with Barton Road?

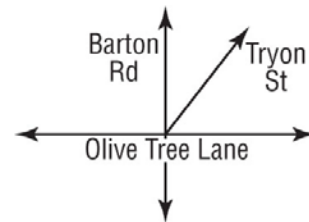

6. **ICOSAHEDRA** For a school project, students are making a giant icosahedron, which is a large solid with many identical triangular faces. John is assigned quality control. He must make sure that the measures of all the angles in all the triangles are the same as each other. He does this by using a precut template and comparing the corner angles of every triangle to the template. How does this assure that the angles in all the triangles will be congruent to each other?

7. **VISTAS** If you look straight ahead at a scenic point, you can see a waterfall. If you turn your head 25° to the left, you will see a famous mountain peak. If you turn your head 35° more to the left, you will see another waterfall. If you are looking straight ahead, through how many degrees must you turn your head to the left in order to see the second waterfall?

8. **TUBES** A tube with a hexagonal cross section is placed on the floor. What is the measure of $\angle 1$ in the figure given that the angle at one corner of the hexagon is 120° ?

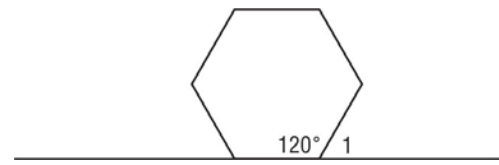

9. **PAINTING** Students are painting their rectangular classroom ceiling. They want to paint a line that intersects one of the corners as shown in the figure. They want the painted line to make a 15° angle with one edge of the ceiling. Unfortunately, between the line and the edge there is a water pipe making it difficult to measure the angle. They decide to measure the angle to the other edge. Given that the corner is a right angle, what is the measure of the other angle?

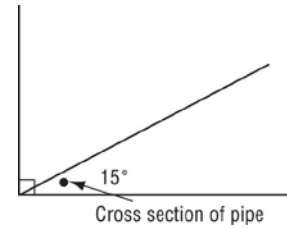

10. **BUILDINGS** Clyde looks at a building from point E . $\angle AEC$ has the same measure as $\angle BED$.

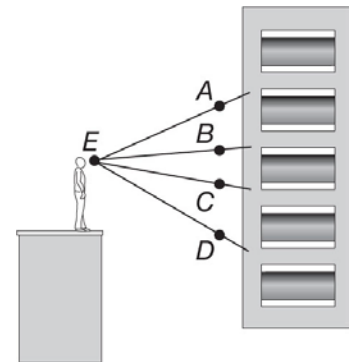

a) The measure of $\angle AEC$ is equal to the sum of the measures of $\angle AEB$ and what other angle?

b) The measure of $\angle BED$ is equal to the sum of the measures of $\angle CED$ and what other angle?

c) Is it true that $m\angle AEB$ is equal to $m\angle CED$?

CHAPTER 3

KeyConcepts Parallel and Skew

Parallel lines are coplanar lines that do not intersect.

Example $\overleftrightarrow{JK} \parallel \overleftrightarrow{LM}$

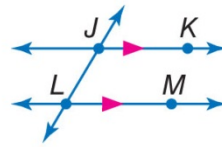

Arrows are used to indicate that lines are parallel.

Skew lines are lines that do not intersect and are not coplanar.

Example Lines ℓ and m are skew.



Parallel planes are planes that do not intersect.

Example Planes \mathcal{A} and \mathcal{B} are parallel.



$\overleftrightarrow{JK} \parallel \overleftrightarrow{LM}$ is read as *line JK is parallel to line LM*.

If segments or rays are contained within lines that are parallel or skew, then the segments or rays are parallel or skew.

Example 1: Use the figure to the right.

a) Name all segments parallel to \overline{BC} .

b) Name a segment skew to \overline{EH} .

c) Name a plane parallel to plane ABG .

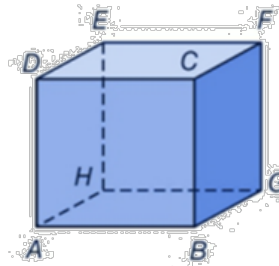

A line that intersects two or more coplanar lines at two different points is called a **transversal**. In the diagram on the next page, line t is a transversal of lines q and r . Notice that line t forms a total of eight angles with lines q and r . These angles, and specific pairings of these angles, are given special names.

KeyConcept Transversal Angle Pair Relationships

Four **interior angles** lie in the region between lines q and r .

$\angle 3, \angle 4, \angle 5, \angle 6$

Four **exterior angles** lie in the two regions that are not between lines q and r .

$\angle 1, \angle 2, \angle 7, \angle 8$

Consecutive interior angles are interior angles that lie on the same side of transversal t .

$\angle 4$ and $\angle 5, \angle 3$ and $\angle 6$

Alternate interior angles are nonadjacent interior angles that lie on opposite sides of transversal t .

$\angle 3$ and $\angle 5, \angle 4$ and $\angle 6$

Alternate exterior angles are nonadjacent exterior angles that lie on opposite sides of transversal t .

$\angle 1$ and $\angle 7, \angle 2$ and $\angle 8$

Corresponding angles lie on the same side of transversal t and on the same side of lines q and r .

$\angle 1$ and $\angle 5, \angle 2$ and $\angle 6, \angle 3$ and $\angle 7, \angle 4$ and $\angle 8$

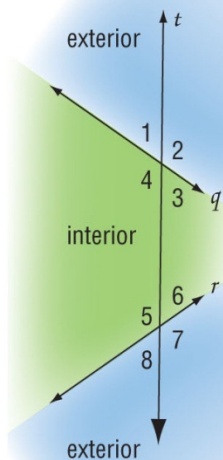

Example 2: Classify the relationship between the given angles as *alternate interior*, *alternate exterior*, *corresponding*, or *consecutive interior* angles.

a) $\angle 2$ and $\angle 6$

b) $\angle 1$ and $\angle 7$

c) $\angle 3$ and $\angle 8$

d) $\angle 3$ and $\angle 5$

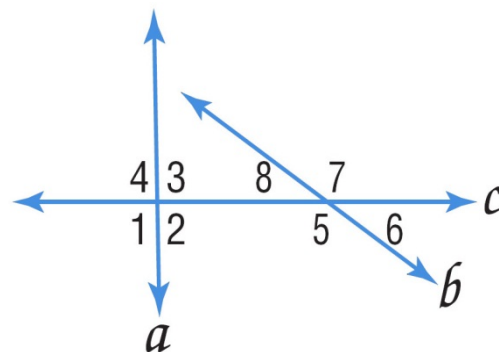

Example 3: Classify the relationship between the given angles as *alternate interior*, *alternate exterior*, *corresponding*, or *consecutive interior* angles.

a) $\angle 4$ and $\angle 5$

b) $\angle 7$ and $\angle 9$

c) $\angle 4$ and $\angle 7$

d) $\angle 2$ and $\angle 11$

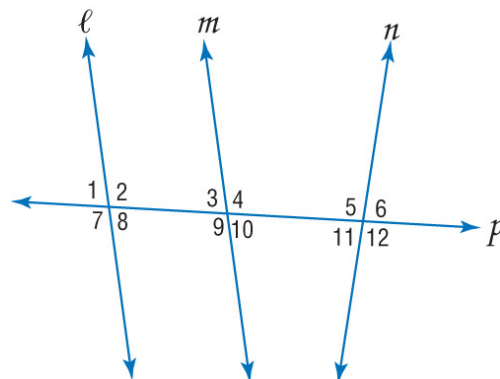

Example 4: BUS STATION The driveways at a bus station are shown. Identify the transversal connecting the given angles. Then classify the relationship between the pair of angles.

a) $\angle 1$ and $\angle 2$

b) $\angle 2$ and $\angle 3$

c) $\angle 4$ and $\angle 5$

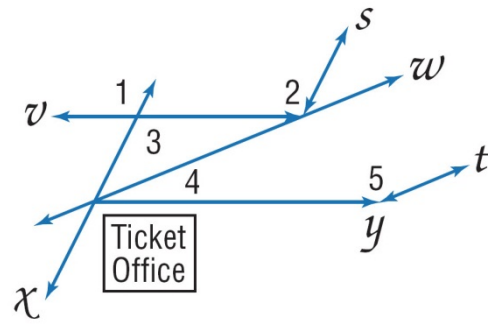

For numbers 1 – 4, refer to the figure at the right to identify each of the following.

1. all planes that intersect plane STX
2. all segments that intersect \overline{QU}
3. all segments that are parallel to \overline{XY} .
4. all segments that are skew to \overline{VW} .

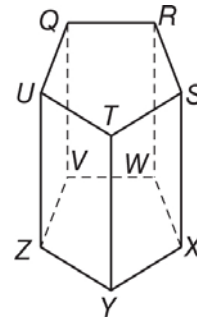

For numbers 5 – 10, classify the relationship between each pair of angles as *alternate interior*, *alternate exterior*, *corresponding*, or *consecutive interior* angles.

- | | |
|-------------------------------|--------------------------------|
| 5. $\angle 2$ and $\angle 10$ | 6. $\angle 7$ and $\angle 13$ |
| 7. $\angle 9$ and $\angle 13$ | 8. $\angle 6$ and $\angle 16$ |
| 9. $\angle 3$ and $\angle 10$ | 10. $\angle 8$ and $\angle 14$ |

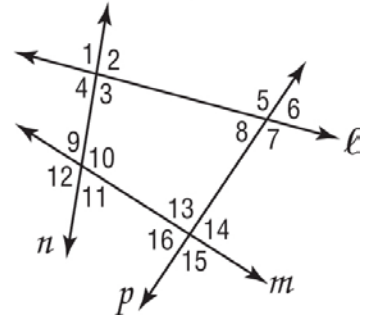

For numbers 11 – 14, name the transversal that forms each pair of angles. Then identify the special name for the angle pair.

- | | |
|---------------------------------|--------------------------------|
| 11. $\angle 2$ and $\angle 12$ | 12. $\angle 6$ and $\angle 18$ |
| 13. $\angle 13$ and $\angle 19$ | 14. $\angle 11$ and $\angle 7$ |

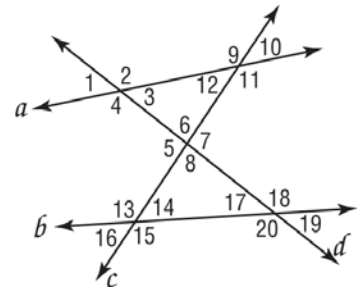

For numbers 15 and 16, refer to the drawing of the end table.

15. Find an example of parallel planes.
16. Find an example of parallel lines.

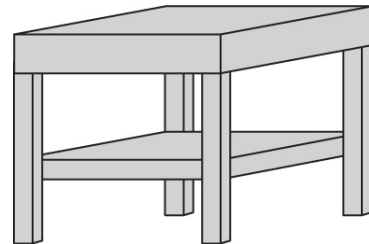

17. **FIGHTERS** Two fighter aircraft fly at the same speed and in the same direction leaving a trail behind them. Describe the relationship between these two trails.

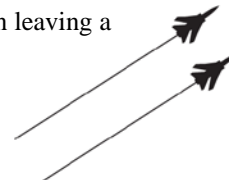

18. **ESCALATORS** An escalator at a shopping mall runs up several levels. The escalator railing can be modeled by a straight line running past horizontal lines that represent the floors. Describe the relationships of these lines.

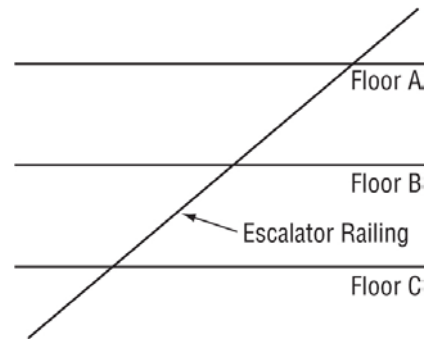

19. **DESIGN** Carol designed the picture frame shown below. How many pairs of parallel segments are there among various edges of the frame?

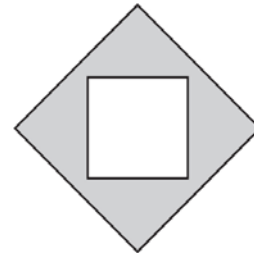

20. **NEIGHBORHOODS** John, Georgia, and Phillip live nearby each other as shown in the map. Describe how their corner angles relate to each other in terms of alternate interior, alternate exterior, corresponding, consecutive interior, or vertical angles.

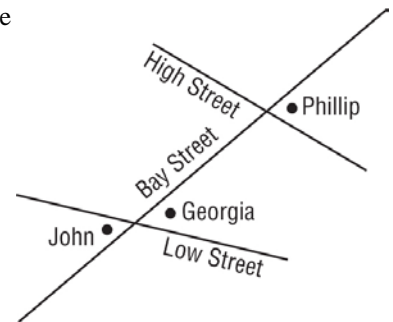

21. **MAPPING** Use the figure to the right.

a) Connor lives at the angle that forms an alternate interior angle with Georgia's residence. Add Connor to the map.

b) Quincy lives at the angle that forms a consecutive interior angle with Connors' residence. Add Quincy to the map.

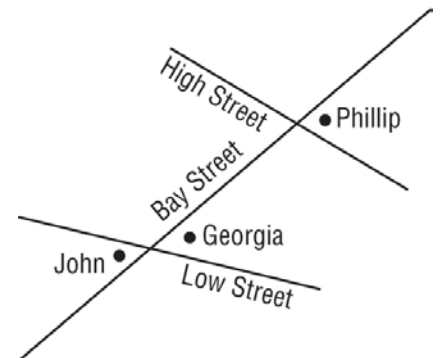

Geometry

Section 3.2 Notes: Angles and Parallel Lines

In the photo, line t is a transversal of lines a and b , and $\angle 1$ and $\angle 2$ are corresponding angles. Since lines a and b are parallel, there is a special relationship between corresponding angle pairs.

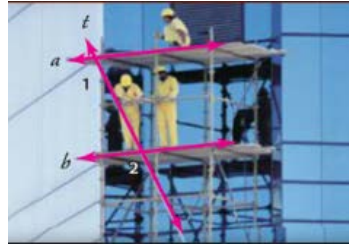

Postulate 3.1 Corresponding Angles Postulate

If two parallel lines are cut by a transversal, then each pair of corresponding angles is congruent.

Examples $\angle 1 \cong \angle 3$, $\angle 2 \cong \angle 4$, $\angle 5 \cong \angle 7$, $\angle 6 \cong \angle 8$

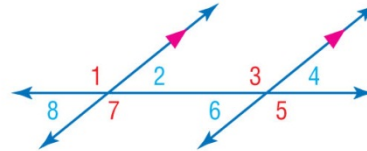

Example 1: Use the diagram below to find the missing angle measure. Tell which postulates (or theorems) you used.

a) If $m\angle 11 = 51^\circ$, find $m\angle 15$.

$\angle 11 \cong \angle$ _____ because....

$m\angle 11 = m\angle$ _____ because....

$m\angle 15 =$ _____ because....

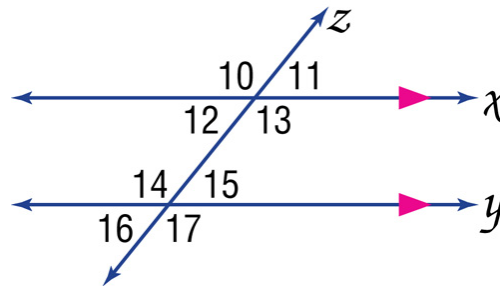

b) If $m\angle 11 = 51^\circ$, find $m\angle 16$.

Theorems Parallel Lines and Angle Pairs

3.1 Alternate Interior Angles Theorem If two parallel lines are cut by a transversal, then each pair of alternate interior angles is congruent.

Examples $\angle 1 \cong \angle 3$ and $\angle 2 \cong \angle 4$

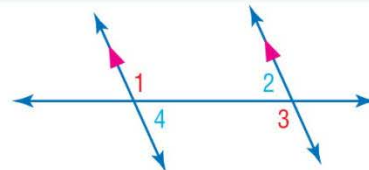

3.2 Consecutive Interior Angles Theorem If two parallel lines are cut by a transversal, then each pair of consecutive interior angles is supplementary.

Examples $\angle 1$ and $\angle 2$ are supplementary.
 $\angle 3$ and $\angle 4$ are supplementary.

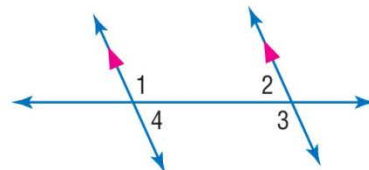

3.3 Alternate Exterior Angles Theorem If two parallel lines are cut by a transversal, then each pair of alternate exterior angles is congruent.

Examples $\angle 5 \cong \angle 7$ and $\angle 6 \cong \angle 8$

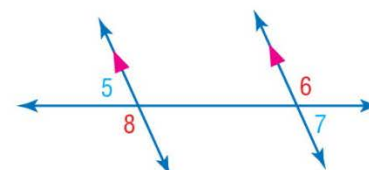

Example 2: The diagram represents the floor tiles in Michelle's house.

a) If $m\angle 2 = 125^\circ$, find $m\angle 3$.

b) If $m\angle 2 = 125^\circ$, find $m\angle 4$.

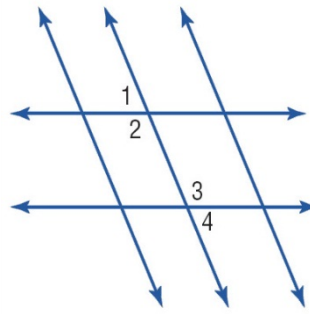

Example 3: Use the diagram below to determine the value of the variable.

a) $m\angle 5 = (2x - 10)^\circ$ and $m\angle 7 = (x + 15)^\circ$

b) $m\angle 4 = (4(y - 25))^\circ$ and $m\angle 8 = (4y)^\circ$

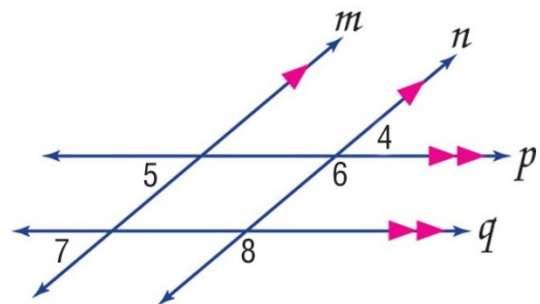

Theorem 3.4 Perpendicular Transversal Theorem

In a plane, if a line is perpendicular to one of two parallel lines, then it is perpendicular to the other.

Examples If line $a \parallel$ line b and line $a \perp$ line t , then line $b \perp$ line t .

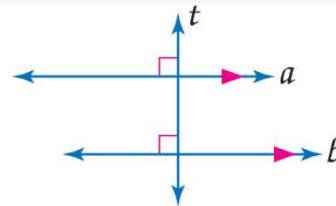

For numbers 1 – 6, use the figure with $m\angle 2 = 92^\circ$ and $m\angle 12 = 74^\circ$. Find the measure of each angle. Tell which postulate(s) or theorem(s) you used.

1. $m\angle 10 =$
2. $m\angle 8 =$
3. $m\angle 9 =$
4. $m\angle 5 =$
5. $m\angle 11 =$
6. $m\angle 13 =$

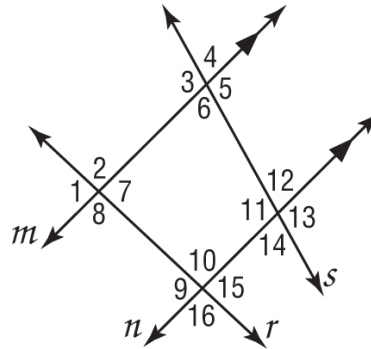

For numbers 7 and 8, find the value of the variable(s) in each figure. Explain your reasoning.

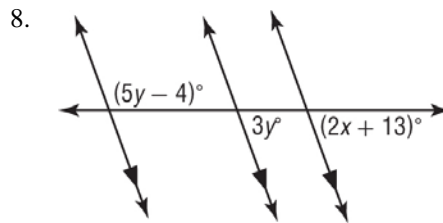
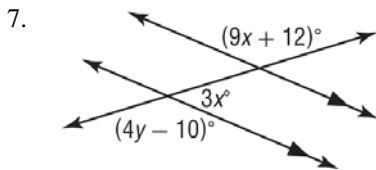

For numbers 9 and 10, solve for x . (*Hint*: Draw an auxiliary line.)

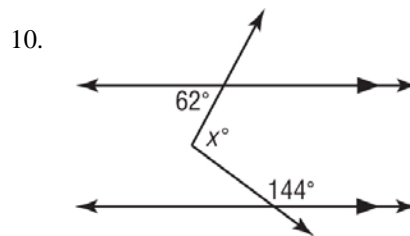
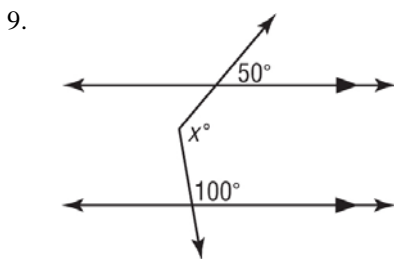

11. **PROOF** Write a paragraph proof of Theorem 3.3.

Given: $\ell \parallel m, m \parallel n$

Prove: $\angle 1 \cong \angle 12$

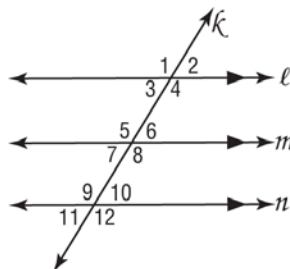

12. **FENCING** A diagonal brace strengthens the wire fence and prevents it from sagging. The brace makes a 50° angle with the wire as shown. Find the value of the variable.

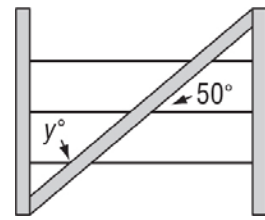

13. **RAMPS** A parking garage ramp rises to connect two horizontal levels of a parking lot. The ramp makes a 10° angle with the horizontal. What is the measure of angle 1 in the figure?

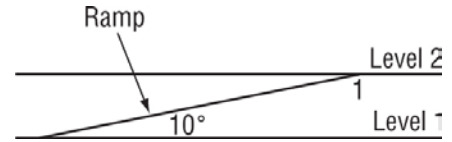

14. **BRIDGES** A double decker bridge has two parallel levels connected by a network of diagonal girders. One of the girders makes a 52° angle with the lower level as shown in the figure. What is the measure of angle 1?

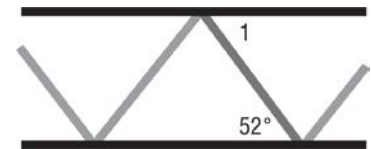

15. **CITY ENGINEERING** Seventh Avenue runs perpendicular to both 1st and 2nd Streets, which are parallel. However, Maple Avenue makes a 115° angle with 2nd Street. What is the measure of angle 1?

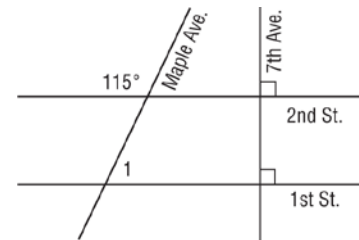

16. **PODIUMS** A carpenter is building a podium. The side panel of the podium is cut from a rectangular piece of wood. The rectangle must be sawed along the dashed line in the figure. What is the measure of angle 1?

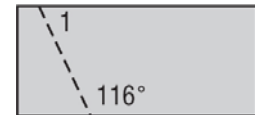

17. **SECURITY** An important bridge crosses a river at a key location. Because it is so important, robotic security cameras are placed at the locations of the dots in the figure. Each robot can scan x degrees. On the lower bank, it takes 4 robots to cover the full angle from the edge of the river to the bridge. On the upper bank, it takes 5 robots to cover the full angle from the edge of the river to the bridge.

a) How are the angles that are covered by the robots at the lower and upper banks related? Derive an equation that x satisfies based on this relationship.

b) How wide is the scanning angle for each robot? What are the angles that the bridge makes with the upper and lower banks?

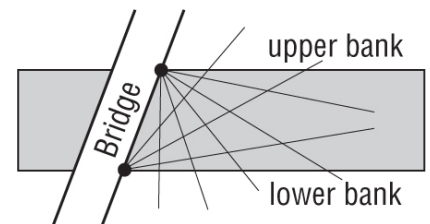

Geometry
Section 3.3 Notes: Slopes of Lines

The steepness or slope of a hill is described by the ratio of the hill's vertical rise to its horizontal run. In algebra, you learned that the slope of a line in the coordinate plane can be calculated using any two points on the line.

KeyConcept Slope of a Line

In a coordinate plane, the **slope** of a line is the ratio of the change along the y -axis to the change along the x -axis between any two points on the line.

The slope m of a line containing two points with coordinates (x_1, y_1) and (x_2, y_2) is given by the formula

$$m = \frac{y_2 - y_1}{x_2 - x_1}, \text{ where } x_1 \neq x_2.$$

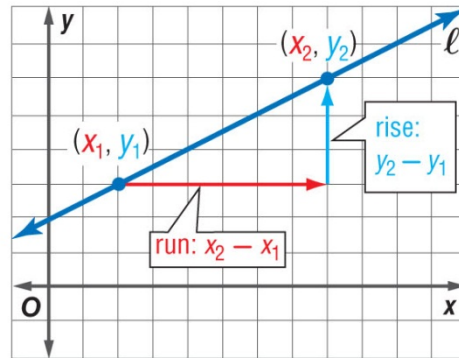

$$m = \frac{\text{rise}}{\text{run}} = \frac{y_2 - y_1}{x_2 - x_1}$$

Example 1: Find the slope of the given lines.

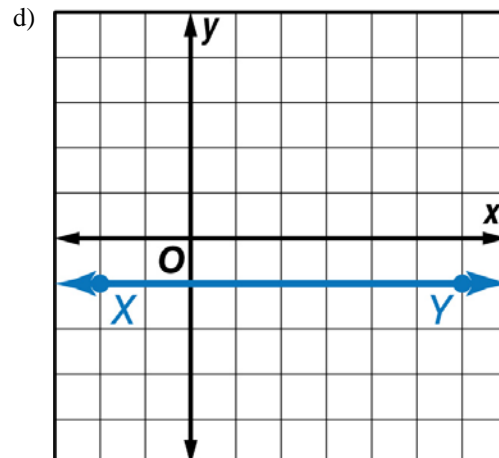
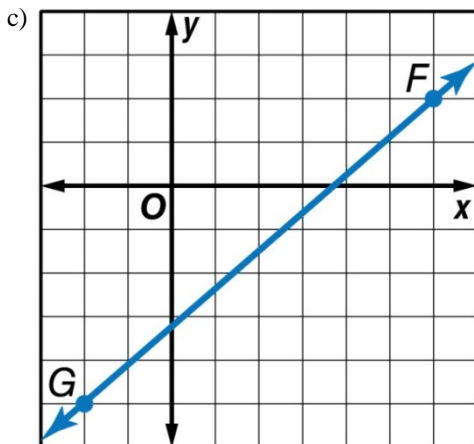
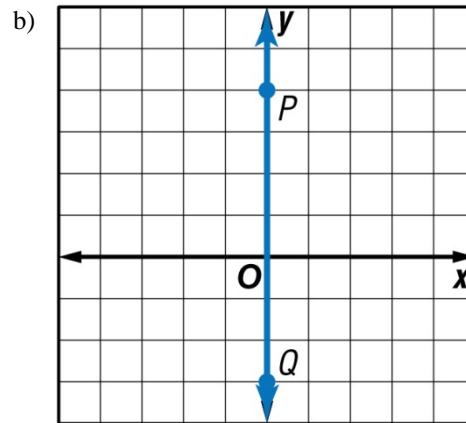
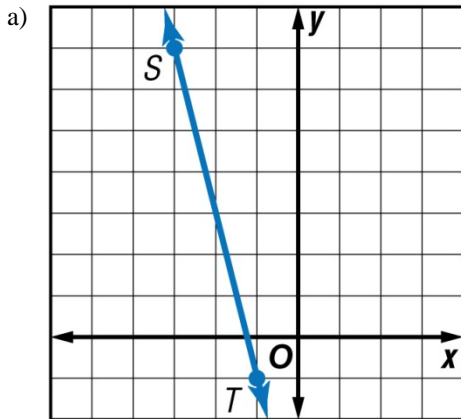

Example 1 illustrates the four different types of slopes.

ConceptSummary Classifying Slopes 

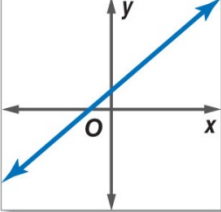
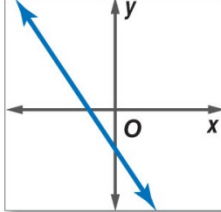
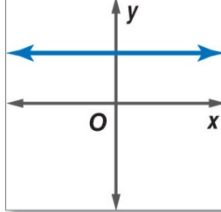
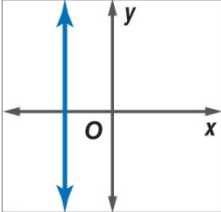
Positive Slope	Negative Slope	Zero Slope	Undefined Slope
			

Example 2: Find the slope of the lines that contain the given points:

a) $(-3, 4), (2, 1)$

b) $(-1, -3), (6, -3)$

c) $(2, -4), (5, 2)$

d) $(3, 5), (3, 2)$

Slope can be interpreted as a **rate of change**, describing how a quantity y changes in relation to quantity x . The slope of a line can also be used to identify the coordinates of any point on the line.

Example 3: In 2000, the annual sales for one manufacturer of camping equipment were \$48.9 million. In 2005, the annual sales were \$85.9 million. If sales increase at the same rate, what will be the total sales in 2015?

Example 4: Between 1994 and 2000, the number of cellular telephone subscribers increased by an average rate of 14.2 million per year. In 2000, the total subscribers were 109.5 million. If the number of subscribers increases at the same rate, how many subscribers will there be in 2010?

You can use the slopes of two lines to determine whether the lines are parallel or perpendicular. Lines with the same slope are parallel.

Postulates Parallel and Perpendicular Lines

3.2 Slopes of Parallel Lines Two nonvertical lines have the same slope if and only if they are parallel. All vertical lines are parallel.

Example Parallel lines ℓ and m have the same slope, 4.

3.3 Slopes of Perpendicular Lines Two nonvertical lines are perpendicular if and only if the product of their slopes is -1 . Vertical and horizontal lines are perpendicular.

Example line $m \perp$ line p
product of slopes = $4 \cdot -\frac{1}{4}$ or -1

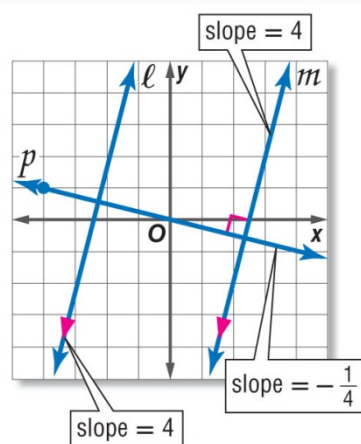

Example 5: Determine whether \overline{FG} and \overline{HJ} are *parallel*, *perpendicular*, or *neither* for $F(1, -3)$, $G(-2, -1)$, $H(5, 0)$, and $J(6, 3)$. Graph each line to verify your answer.

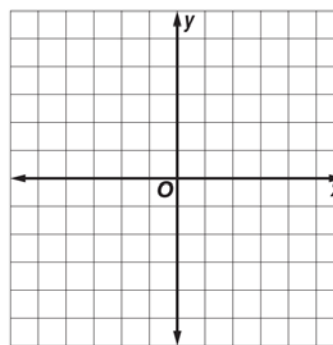

Example 6: Determine whether \overline{AB} and \overline{CD} are *parallel*, *perpendicular*, or *neither* for $A(-2, -1)$, $B(4, 5)$, $C(6, 1)$, and $D(9, -2)$.

Example 7: Graph the line that contains $Q(5, 1)$ and is parallel to \overline{MN} with $M(-2, 4)$ and $N(2, 1)$.

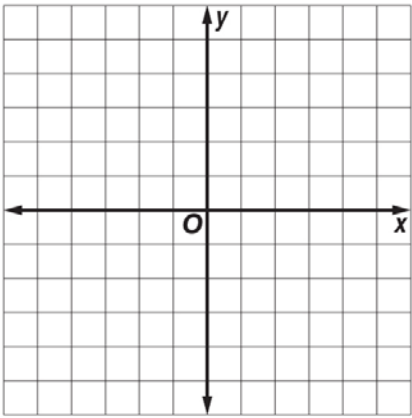

Example 8: Determine which graph represents the line that contains $R(2, -1)$ and is parallel to \overline{OP} with $O(1, 6)$ and $P(-3, 1)$.

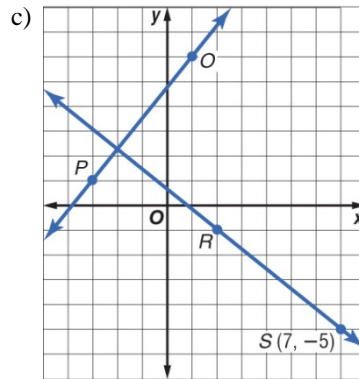
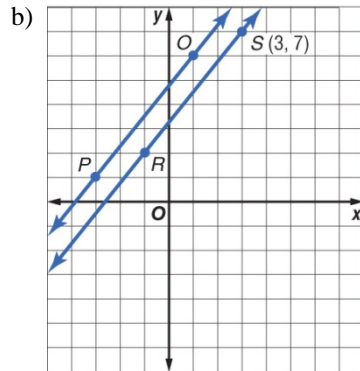
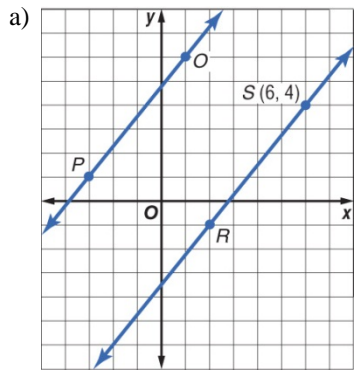

d) None of these

For numbers 1 and 2, determine the slope of the line that contains the given points.

1. $B(-4, 4), R(0, 2)$

2. $I(-2, -9), P(2, 4)$

For numbers 3 – 6, find the slope of each line.

3. \overline{LM}

4. \overline{GR}

5. a line parallel to \overline{GR}

6. a line perpendicular to \overline{PS}

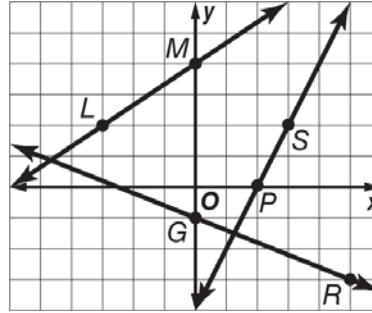

For numbers 7 – 10, determine whether \overline{KM} and \overline{ST} are *parallel*, *perpendicular*, or *neither*.

7. $K(-1, -8), M(1, 6), S(-2, -6), T(2, 10)$

8. $K(-5, -2), M(5, 4), S(-3, 6), T(3, -4)$

9. $K(-4, 10), M(2, -8), S(1, 2), T(4, -7)$

10. $K(-3, -7), M(3, -3), S(0, 4), T(6, -5)$

For numbers 11 – 14, graph the line that satisfies each condition.

11. slope = $-\frac{1}{2}$, contains $U(2, -2)$

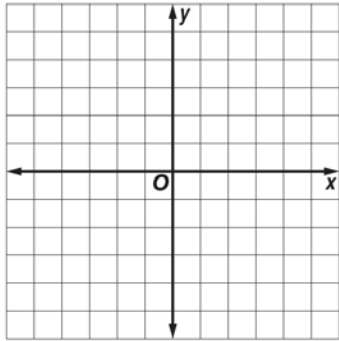

12. slope = $\frac{4}{3}$, contains $P(-3, -3)$

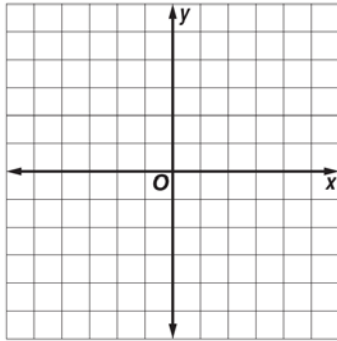

13. Contains $B(-4, 2)$, parallel to \overline{FG} with $F(0, -3)$ and $G(4, -2)$

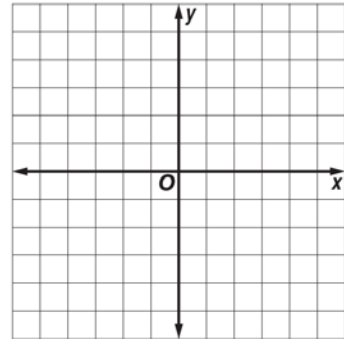

14. Contains $Z(-3, 0)$, perpendicular to \overline{EK} with $E(-2, 4)$ and $K(2, -2)$

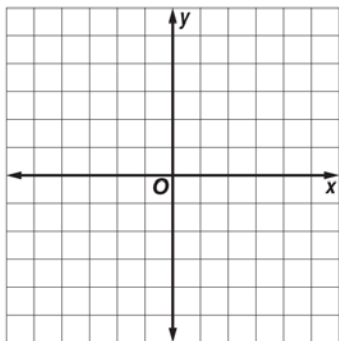

15. **PROFITS** After Take Two began renting DVDs at their video store, business soared. Between 2005 and 2010, profits increased at an average rate of \$9000 per year. Total profits in 2010 were \$45,000. If profits continue to increase at the same rate, what will the total profit be in 2014?

16. **HIGHWAYS** A highway on-ramp rises 15 feet for every 100 horizontal feet traveled. What is the slope of the ramp?

17. **DESCENT** An airplane descends at a rate of 300 feet for every 5000 horizontal feet that the plane travels. What is the slope of the path of descent?

18. **ROAD TRIP** Jenna is driving 400 miles to visit her grandmother. She manages to travel the first 100 miles of her trip in two hours. If she continues at this rate, how long will it take her to drive the remaining distance?

19. **WATER LEVEL** Before the rain began, the water in a lake was 268 inches deep. The rain began and after four hours of rain, the lake was 274 inches deep. The rain continued for one more hour at the same intensity. What was the depth of the lake when the rain stopped?

20. **CITY BLOCKS** The figure shows a map of part of a city consisting of two pairs of parallel roads. If a coordinate grid is applied to this map, Ford Street would have a slope of -3 .

a) The intersection of B Street and Ford Street is 150 yards east of the intersection of Ford Street and Clover Street. How many yards south is it?

b) What is the slope of 6th Street? Explain.

c) What are the slopes of Clover and B Streets? Explain.

d) The intersection of B Street and 6th Street is 600 yards east of the intersection of B Street and Ford Street. How many yards north is it?

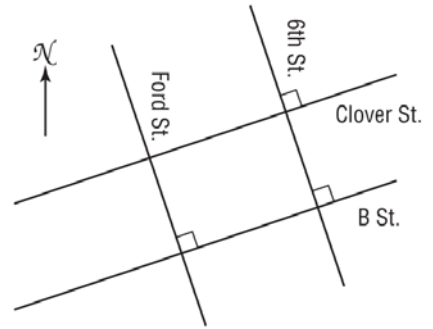

Geometry

3.4 Notes: Equations of Lines

You may remember from algebra that an equation of a nonvertical line can be written in different but equivalent forms.

KeyConcept Nonvertical Line Equations

The **slope-intercept form** of a linear equation is $y = mx + b$, where m is the slope of the line and b is the y -intercept.

$$y = mx + b \qquad y = 3x + 8$$

slope \swarrow \searrow
y-intercept \swarrow \searrow

The **point-slope form** of a linear equation is $y - y_1 = m(x - x_1)$, where (x_1, y_1) is any point on the line and m is the slope of the line.

$$y - 5 = -2(x - 3)$$

point on line (3, 5)
slope \swarrow \searrow

When given the slope and either the y -intercept or a point on a line, you can use these forms to write the equation of the line.

Example 1:

a) Write an equation in slope-intercept form of the line with slope of 6 and y -intercept of -3 . Then graph the line.

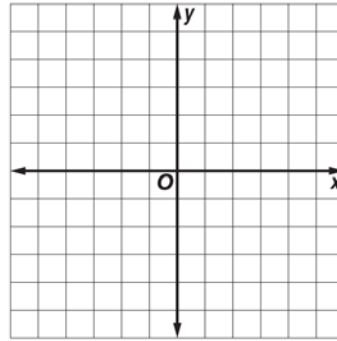

b) Write an equation in slope-intercept form of the line with slope of -1 and y -intercept of 4.

Example 2:

a) Write an equation in point-slope form of the line whose slope is $-\frac{3}{5}$ that contains $(-10, 8)$. Then graph the line.

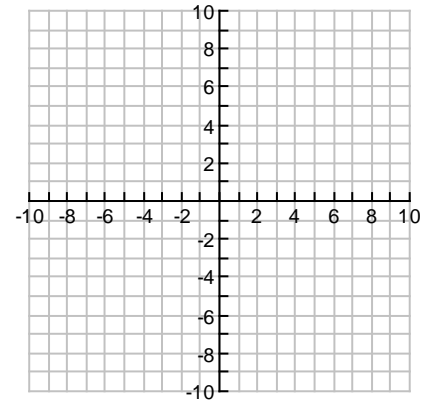

b) Write an equation in point-slope form of the line whose slope is $\frac{1}{3}$ that contains $(6, -3)$.

When the slope of a line is not given, use two points on the line to calculate the slope. Then use point-slope or slope-intercept form to write an equation of the line.

Example 3:

a) Write an equation in slope-intercept form for a line containing (4, 9) and (-2, 0).

b) Write an equation in slope-intercept form for a line containing (-3, -7) and (-1, 3).

Example 4: Write an equation of the line through (5, -2) and (0, -2) in slope-intercept form.

The equations of horizontal and vertical lines involve only one variable.

KeyConcepts Horizontal and Vertical Line Equations

The equation of a horizontal line is $y = b$, where b is the y -intercept of the line.

Example $y = -3$

The equation of a vertical line is $x = a$, where a is the x -intercept of the line.

Example $x = -2$

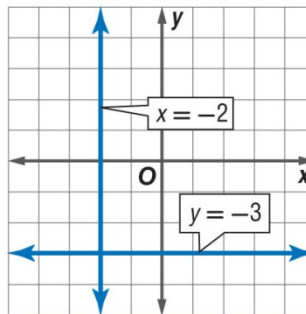

Parallel lines that are not vertical have equal slopes. Two nonvertical lines are perpendicular if the product of their slopes is -1 . Vertical and horizontal lines are always perpendicular to one another.

Example 5:

a) Write an equation in slope-intercept form for a line perpendicular to the line $y = \frac{1}{5}x + 2$ through (2, 0).

b) Write an equation in slope-intercept form for a line perpendicular to the line $y = \frac{1}{3}x + 2$ through $(0, 8)$.

Many real-world situations can be modeled using a linear equation.

Example 6: An apartment complex charges \$525 per month plus a \$750 annual maintenance fee.

a) Write an equation to represent the total first year's cost, A , for r months of rent.

b) Compare this rental cost to a complex which charges a \$200 annual maintenance fee but \$600 per month to rent. If a person expects to stay in an apartment for one year, which complex offers the better rate?

Example 7: A car rental company charges \$25 per day plus a \$100 deposit.

a) Write an equation to represent to the total cost, C , for d days of use.

b) Compare this rental cost to a company which charges a \$50 deposit but \$35 per day for use. If a person expects to rent a car for 9 days, which company offers the better rate?

For numbers 1 – 3, write an equation in slope-intercept form of the line having the given slope and y-intercept or given points. Then graph the line.

1. $m: \frac{2}{3}, b: -10$

2. $m: -\frac{7}{9}, \left(0, -\frac{1}{2}\right)$

3. $m: 4.5, (0, 0.25)$

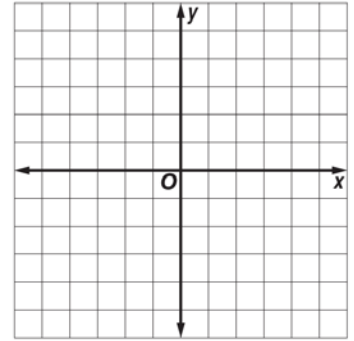
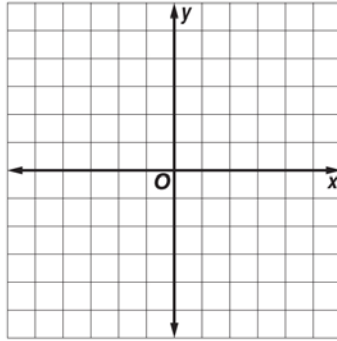
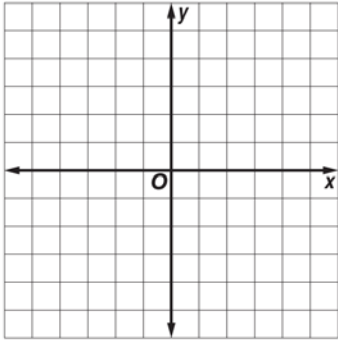

For numbers 4 – 7, write equations in point-slope form of the line having the given slope that contains the given point. Then graph the line.

4. $m: \frac{3}{2}, (4, 6)$

5. $m: -\frac{6}{5}, (-5, -2)$

6. $m: 0.5, (7, -3)$

7. $m: -1.3, (-4, 4)$

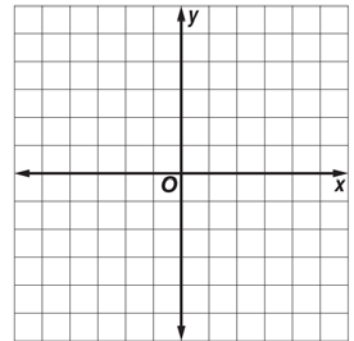
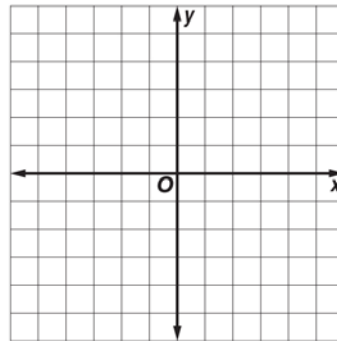
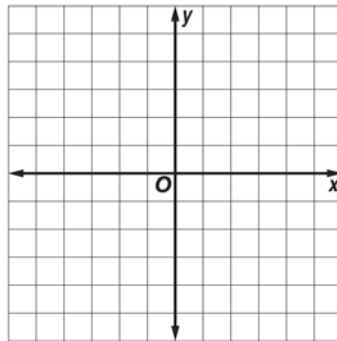
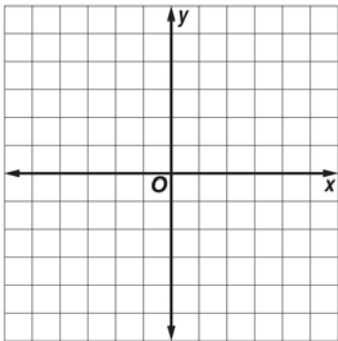

For numbers 8 – 17, write an equation in slope-intercept form for each line shown or described.

8. b

9. c

10. parallel to line b , contains $(3, -2)$

11. perpendicular to line c , contains $(-2, -4)$

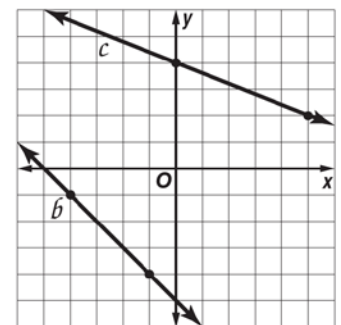

12. $m = -\frac{4}{9}$, $b = 2$

13. $m = 3$, contains $(2, -3)$

14. x -intercept is -6 , y -intercept is 2

15. x -intercept is 2 , y -intercept is -5

16. passes through $(2, -4)$ and $(5, 8)$

17. contains $(-4, 2)$ and $(8, -1)$

18. **COMMUNITY EDUCATION** A local community center offers self-defense classes for teens. A \$25 enrollment fee covers supplies and materials and open classes cost \$10 each. Write an equation to represent the total cost of x self-defense classes at the community center.

19. **GROWTH** At the same time each month over a one year period, John recorded the height of a tree he had planted. He then calculated the average growth rate of the tree. The height h in inches of the tree during this period was given by the formula $h = 1.7t + 28$, where t is the number of months. What are the slope and y -intercept of this line and what do they signify?

20. **DRIVING** Ellen is driving to a friend's house. The graph shows the distance (in miles) that Ellen was from home t minutes after she left her house. Write an equation that relates m and t .

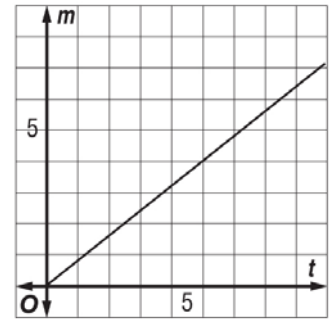

21. **COST** Carla has a business that tests the air quality in artist's studios. She had to purchase \$750 worth of testing equipment to start her business. She charges \$50 to perform the test. Let n be the number of jobs she gets and let P be her net profit. Write an equation that relates P and n . How many jobs does she need to make \$750?

22. **PAINT TESTING** A paint company decided to test the durability of its white paint. They painted a square all white with their paint and measured the reflectivity of the square each year. Seven years after being painted, the reflectivity was 85%. Ten years after being painted, the reflectivity dropped to 82.9%. Assuming that the reflectivity decreases steadily with time, write an equation that gives the reflectivity R (as a percentage) as a function of time t in years. What is the reflectivity of a fresh coat of their white paint?

23. **ARTISTRY** Gail is an oil painter. She paints on canvases made from Belgian linen. Before she paints on the linen, she has to prime the surface so that it does not absorb the oil from the paint she uses. She can buy linen that has already been primed for \$21 per yard, or she can buy unprimed linen for \$15 per yard, but then she would also have to buy a jar of primer for \$30.

a) Let P be the cost of Y yards of primed Belgian linen. Write an equation that relates P and Y .

b) Let U be the cost of buying Y yards of unprimed linen and a jar of primer. Write an equation that relates U and Y .

c) For how many yards would it be less expensive for Gail to buy the primed linen?

Postulate 3.4 Converse of Corresponding Angles Postulate

If two lines are cut by a transversal so that corresponding angles are congruent, then the lines are parallel.

Examples If $\angle 1 \cong \angle 3$, $\angle 2 \cong \angle 4$, $\angle 5 \cong \angle 7$,
 $\angle 6 \cong \angle 8$, then $a \parallel b$.

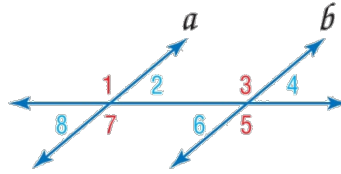

Postulate 3.5 Parallel Postulate

If given a line and a point not on the line, then there exists exactly one line through the point that is parallel to the given line.



Parallel lines that are cut by a transversal create several pairs of congruent angles. These special angle pairs can also be used to prove that a pair of lines are parallel.

Theorems Proving Lines Parallel

3.5 Alternate Exterior Angles Converse

If two lines in a plane are cut by a transversal so that a pair of alternate exterior angles is congruent, then the two lines are parallel.

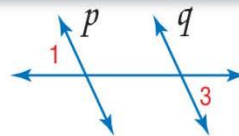

If $\angle 1 \cong \angle 3$, then $p \parallel q$.

3.6 Consecutive Interior Angles Converse

If two lines in a plane are cut by a transversal so that a pair of consecutive interior angles is supplementary, then the lines are parallel.

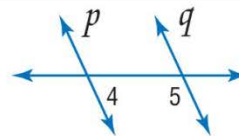

If $m\angle 4 + m\angle 5 = 180$, then $p \parallel q$.

3.7 Alternate Interior Angles Converse

If two lines in a plane are cut by a transversal so that a pair of alternate interior angles is congruent, then the lines are parallel.

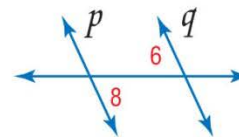

If $\angle 6 \cong \angle 8$, then $p \parallel q$.

3.8 Perpendicular Transversal Converse

In a plane, if two lines are perpendicular to the same line, then they are parallel.

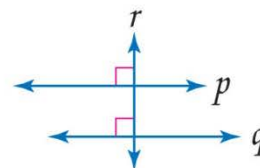

If $p \perp r$ and $q \perp r$, then $p \parallel q$.

Example 1: Use the diagram to the right.

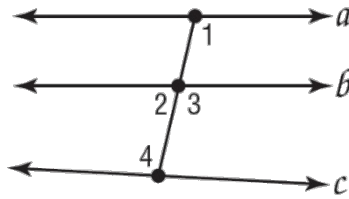

a) Given $\angle 1 \cong \angle 3$, is it possible to prove that any of the lines shown are parallel? If so, state the postulate or theorem that justifies your answer.

b) Given $m\angle 1 = 103^\circ$ and $m\angle 4 = 100^\circ$, is it possible to prove that any of the lines shown are parallel? If so, state the postulate or theorem that justifies your answer.

Example 2: Given $\angle 1 \cong \angle 5$, is it possible to prove that any of the lines shown are parallel?

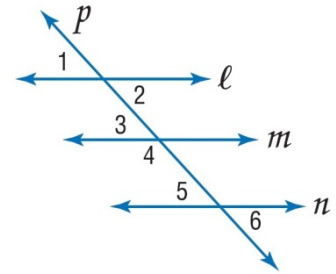

Angle relationships can be used to solve problems involving unknown values.

Example 3:

a) Find $m\angle ZYN$ so that $\overline{PQ} \parallel \overline{MN}$. Show your work.

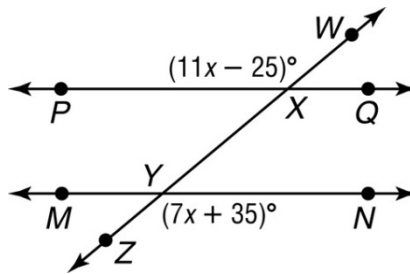

b) Find x so that $\overline{GH} \parallel \overline{RS}$.

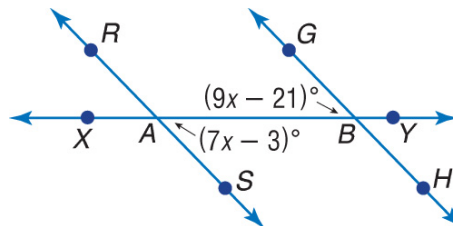

The angle pair relationship formed by a transversal can be used to prove that two lines are parallel.

Example 4: In the window shown, the diamond grid pattern is constructed by hand. Is it possible to ensure that the wood pieces that run the same direction are parallel? If so, explain how. If not, explain why not.

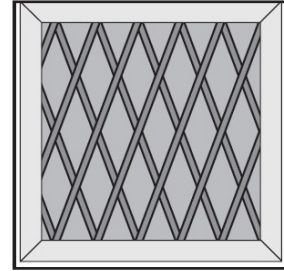

Example 5: In the game Tic-Tac-Toe, four lines intersect to form a square with four right angles in the middle of the grid. Is it possible to prove any of the lines parallel or perpendicular? Choose the best answer.

- a) The two horizontal lines are parallel.
- b) The two vertical lines are parallel.
- c) The vertical lines are perpendicular to the horizontal lines.
- d) All of these statements are true.

For numbers 1 – 4, use the given following information to determine which lines, if any, are parallel. State the postulate or theorem that justifies your answer.

1. $m\angle BCG + m\angle FGC = 180^\circ$

2. $\angle CBF \cong \angle GFH$

3. $\angle EFB \cong \angle FBC$

4. $\angle ACD \cong \angle KBF$

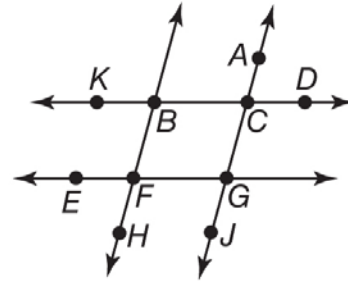

For numbers 5 – 7, solve for x so that $l \parallel m$. Identify the postulate or theorem you used.

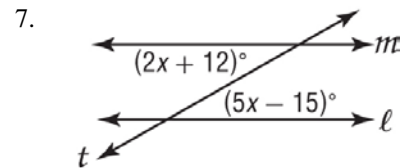
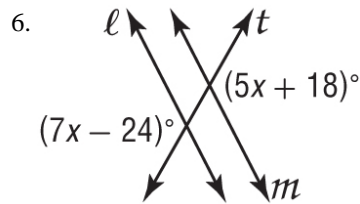
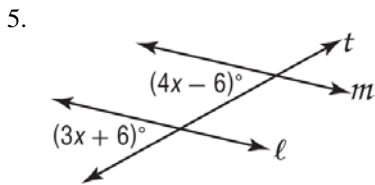

8. **PROOF** Write a two-column proof.
Given: $\angle 2$ and $\angle 3$ are supplementary.
Prove: $\overline{AB} \parallel \overline{CD}$

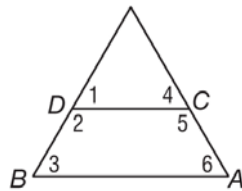

9. **LANDSCAPING** The head gardener at a botanical garden wants to plant rosebushes in parallel rows on either side of an existing footpath. How can the gardener ensure that the rows are parallel?

10. **RECTANGLES** Jim made a frame for a painting. He wants to check to make sure that opposite sides are parallel by measuring the angles at the corners and seeing if they are right angles. How many corners must he check in order to be sure that the opposite sides are parallel?

11. **BOOKS** The two gray books on the bookshelf each make a 70° angle with the base of the shelf. What more can you say about these two gray books?

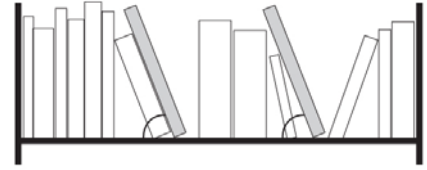

12. **PATTERNS** A rectangle is cut along the slanted, dashed line shown in the figure. The two pieces are rearranged to form another figure. Describe as precisely as you can the shape of the new figure. Explain.

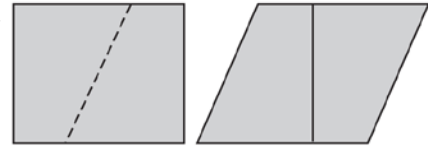

13. **FIREWORKS** A fireworks display is being readied for a celebration. The designers want to have four fireworks shoot out along parallel trajectories. They decide to place two launchers on a dock and the other two on the roof of a building. To pull off this display, what should the measure of angle 1 be?

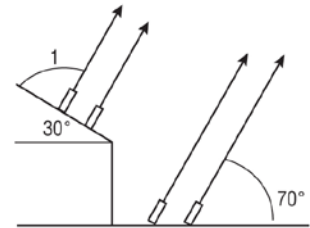

14. **SIGNS** Harold is making a giant letter “A” to put on the rooftop of the “A is for Apple” Orchard Store. The figure shows a sketch of the design.

a) What should the measures of angles 1 and 2 be so that the horizontal part of the “A” is truly horizontal?



b) When building the “A,” Harold makes sure that angle 1 is correct, but when he measures angle 2, it is not correct. What does this imply about the “A”?



KeyConcept Distance Between a Point and a Line

Words The distance between a line and a point not on the line is the length of the segment perpendicular to the line from the point.

Model

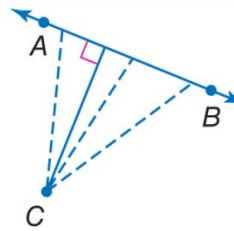

The construction of a line perpendicular to an existing line through a point not on the existing line in Extend Lesson 1-5 establishes that there is *at least one* line through a point, P , that is perpendicular to a line, AB . The following postulate states that this line is the *only* line through P perpendicular to \overline{AB} .

Postulate 3.6 Perpendicular Postulate

Words If given a line and a point not on the line, then there exists exactly one line through the point that is perpendicular to the given line.

Model

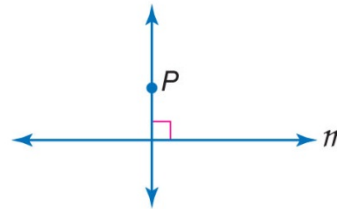

Example 1:

a) A certain roof truss is designed so that the center post extends from the peak of the roof (point A) to the main beam. Construct and name the segment whose length represents the shortest length of wood that will be needed to connect the peak of the roof to the main beam.

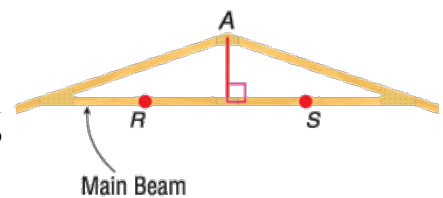

b) Which segment represents the shortest distance from point A to \overline{DB} .

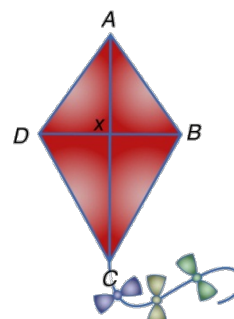

For numbers 1 – 3, construct the segment that represents the distance indicated.

1. O to \overline{MN}

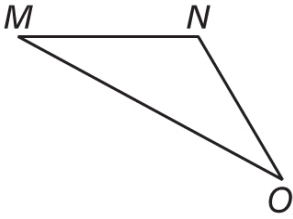

2. A to \overline{DC}

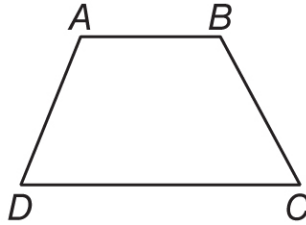

3. T to \overline{VU}

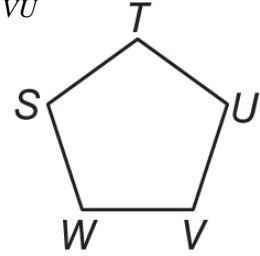

4. **DISTANCE** Paul is standing in the schoolyard. The figure shows his distance from various classroom doors lined up along the same wall. How far is Paul from the wall itself?

