

Flex-Rail (FR4.5) Guardrail Marker

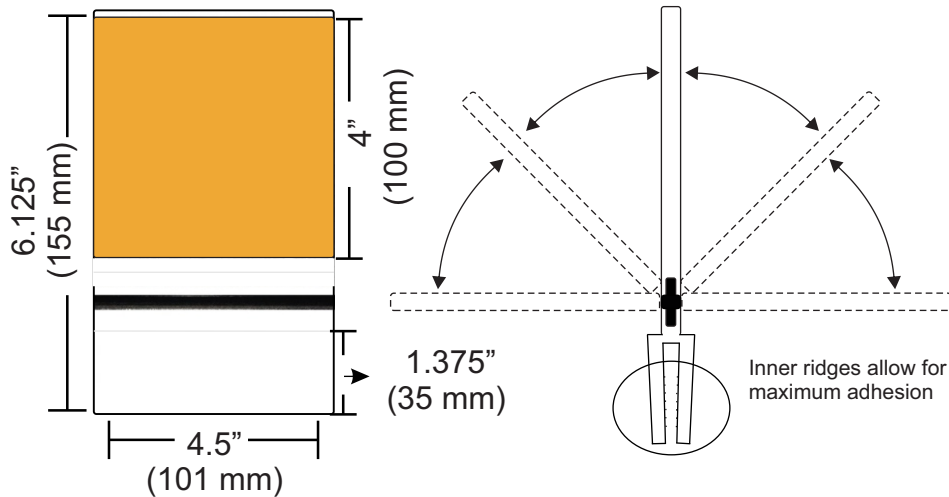

Available in **ANY** width



Pre-drilled holes available

The 4.50" wide **FLEX-RAIL (FR)** body will retain its original shape after being hit repeatedly. The marker body is made of rigid PVC with co-extruded 80 durometer polyurethane acting as a working hinge.

The polyurethane hinge material recesses into the base and body sections of the **Flex-Rail**. This allows the PVC to grab onto the polyurethane and ensures the bond between the hinge and body is never broken.

Artuk's **Flex-Rail** can meet ANY reflectivity level required by Federal, State, Local and International municipalities.

ASTM D-4956 Reflectivity Level

Type I, III/IV, VIII, IX & XI

Colors:

White, Yellow, Orange, Blue, Green, Red, Brown, Fluorescent Yellow, Fluorescent Yellow-Green, Fluorescent Orange

Part #

FR4.5-1 Single Sided Sheeting
FR4.5-2 Double Sided Sheeting

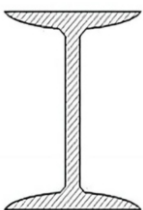

INSTALLATION INSTRUCTIONS:

FLEX-RAIL (FR) Delineators are mounted directly (slotting over the top) of a metal I Beam support post using our manufacturer recommended Adhesive that can be applied to the Slot of the FR

Application Rate: 35 Units/Tube of Adhesive Cement (3" wide FR's)