

***Owner's Manual
for DentaLaire Prestige
Dental Stations***

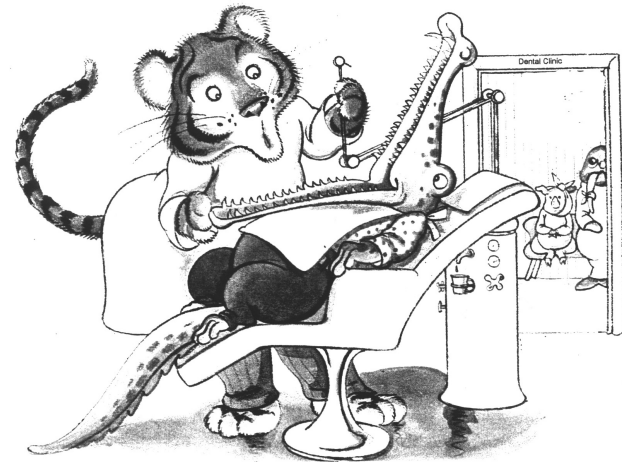

DENTALAIRE™ 

Toll Free (800) 866-6881
Fax (714) 540-9947
www.dentalaireproducts.com
17150 Newhope Street, Suite 407, Fountain Valley, CA 92708

DENTALAIRE™ 

CAUTION: Never, ever use worn out tips. This will result in severe damage to the handpiece and could cost you a lot to get it repaired. Please routinely check the tips by using the chart provided, which shows expected tip wear. Remember, if you are having to constantly adjust the power setting up, the tips are probably worn and need to be replaced.

To clean the tips, do the following:

1. Brush off and rinse the tip with water.
2. It can be sterilized with a cold sterile solution or put in a ultrasonic cleaner.
3. Autoclave the tips at 275°F for no longer than 15 minutes.

Enjoy your new dental unit. Please call us at (800)866-6881 if you have any questions. We are here to help in any way we can.

- For High-speed, slowspeed polisher, blue metal airscaler, prophyl angles and contra angles questions, ask for Debbie McCullah.
- For Technical Questions on dental machines, call Paul, Daniel and Wes.
- For all other questions, ask for Daniel Strange.

Please note: If you have any kind of damage, please notify Dentalaire right away. We have a two week window where we can make a claim if there are any damages to the dental station. After that, if you get a dental station from us, have it for a month, open it up and then find damages, we cannot get any kind of credit from our shipper. This makes it very difficult for all parties involved. Thanks for your help in this matter.

SELECTION OF HANDPIECES

Your dental station comes with a high-speed and a Low-speed handpiece. The high-speed is for drilling and sectioning of the teeth. The low speed is used mainly for polishing. It also can have an air scaler or a piezo scaler, which is used to scale (clean) the teeth.

OPERATION OF HANDPIECES

High-Speed Handpiece operates at pressures of 38 to 40 PSI and attains a speed of 350,000 to 400,000 RPM. The water mist helps to keep the handpiece motor and bur cool, as well as the patient's tooth cool while doing restorations, cutting or rotary prophyl scaling procedures.

Constant preventive maintenance is essential in caring for handpieces. If they are not properly cleaned and lubricated, abrasives such as finely ground tooth, metal will cause excessive wear and undue vibration.

When inserting and removing burs from handpieces, use the bur tool by holding it between the thumb and forefinger. Slide the bur tool over the head of the handpiece. Pull the wrench knob away from the head, then push the knob back to engage the chuck. The square tip of the wrench must fit into the square hole inside of the handpiece head (this is the chuck). To remove the bur, rotate the wrench one full turn Counter Clockwise until the bur is free. To tighten, rotate the wrench one full turn Clockwise until the bur is secure.

Never overtighten the bur, as serious damage can result to the chuck and bur tool.

On units that have a push button bur changer, to insert the bur simply push your thumb on the back cap of the high speed handpiece to engage the chuck. You will feel a click, and then you insert the bur all the way as far as you can. To take out repeat the above step and then pull out the bur.

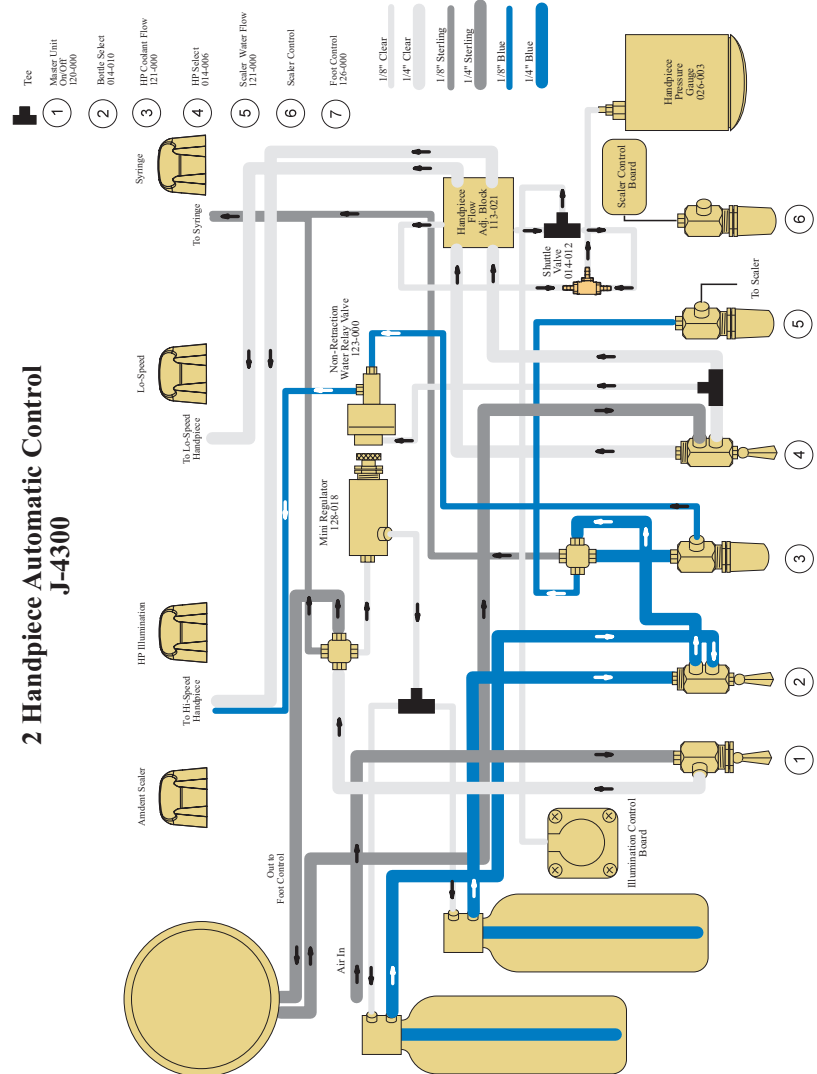

2 Handpiece Automatic Control J-4300

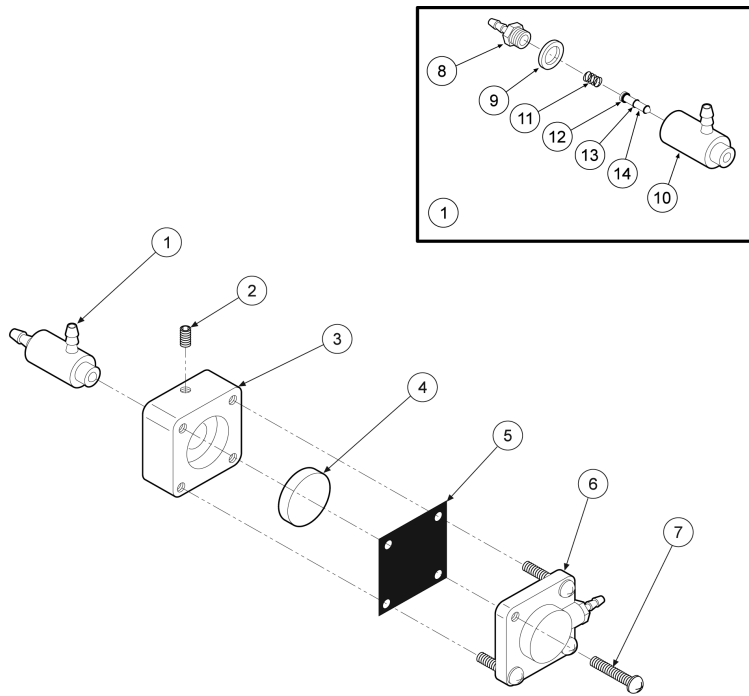

Non-Retraction Water Relay Valve



Push Button Bur



Bur Tool Changing

If you do not put the bur in all the way it will damage the chuck. You will then need to purchase a new turbine for your high speed handpiece.

Slow-Speed Handpiece operates at pressures of 40 PSI and generates speeds from a crawl to 5500 RPM depending on the pressure applied to the foot control. The slow speed should be placed on the right side of the delivery system (dry side), as no coolant is needed for the slow speed procedures.

As with the high speed handpiece, always read and follow manufacturer's instructions for operation, lubrication, cleaning, and sterilization for the slow speed motor and attachments.

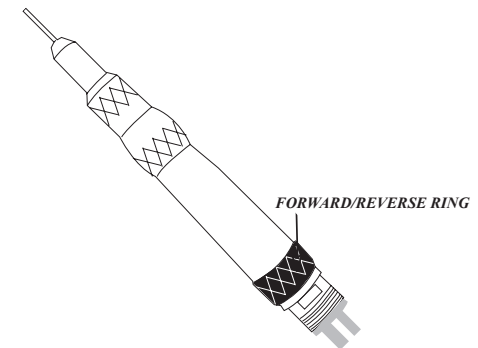

Slow-Speed Handpiece
Nose Portion Swivels 360° To Reduce Hand Fatigue

To attach prophyl angles, contra angles, cutting wheels or handpiece burs to the handpiece, simply turn lock ring to unlock position slide in prophyl angle then turn to lock position. Please note: If the prophyl angle ever gets stuck, once you have removed it you can squirt a little Once A Day Spray Lubricant into the bottom of the prophyl angle. This should help resolve the problem.

CAUTION: Do not run slow-speed unless an angle or bur is installed as serious chuck damage will result.

CLEANING OF HIGH-SPEED AND SLOW-SPEED HANDPIECES

Before cleaning procedures the bur must be removed from the handpiece. The handpiece must be cleaned with a brush or wiped with alcohol after each patient.

Never use any type of chemicals to clean these handpieces. This includes Nolvasan, Roccal D, chemicals used in Ultrasonic cleaners. These cleaners will ruin the turbines and bearings in the handpieces.

STERILIZATION OF HIGH AND SLOW-SPEED HANDPIECES

1. The handpiece must be sterilized by autoclave for 15 minutes at 135°C (275°F).
Do not exceed 275°F when autoclaving.
2. Only use non chlorine products, and no chemical solutions.
3. Do not sterilize the high speed handpiece with the bur inserted. Also, never sterilize the low speed with the prophyl angle attached.
4. Always lubricate the handpieces before you autoclave them, then once handpiece has returned to room temperature you should lubricate it again.

REPAIR AND REPLACING THE HIGH-SPEED CARTRIDGE

Only use the original replacement turbines, for total assurance of quality control and product life. The cartridge is a fragile instrument. Please call our service department if you have questions or need help in replacing this part.

DA400RC – Standard Type Turbine

DA400RCA – Push Button Turbine w/Cap

DASKA485 – Push Button Turbine Only

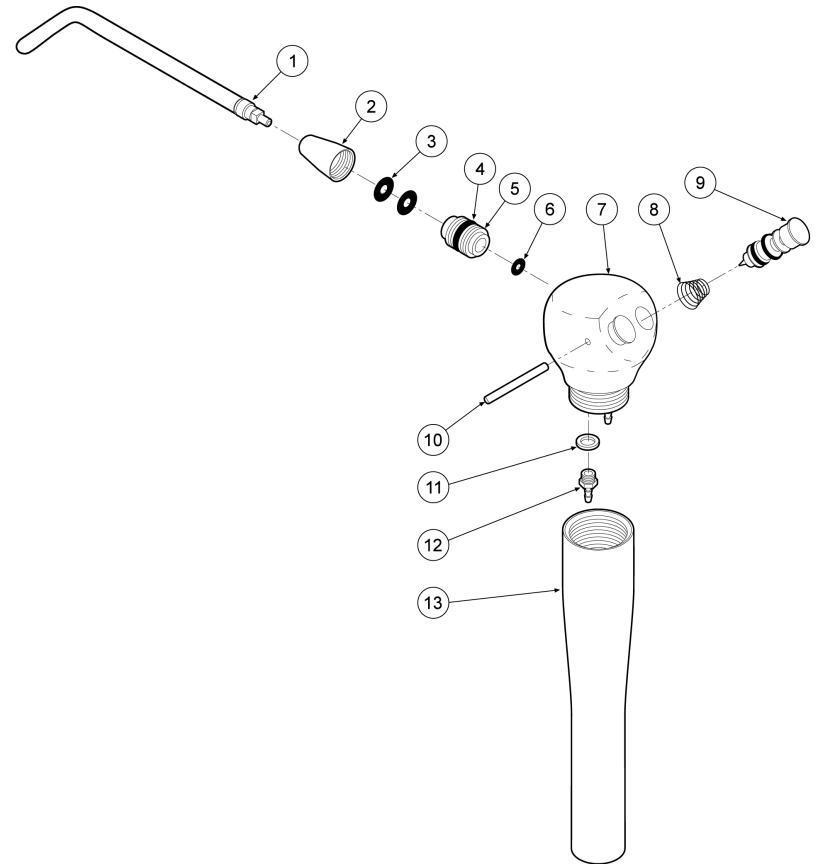

3-Way IC Syringe

Foot Control with Chip-Air Button

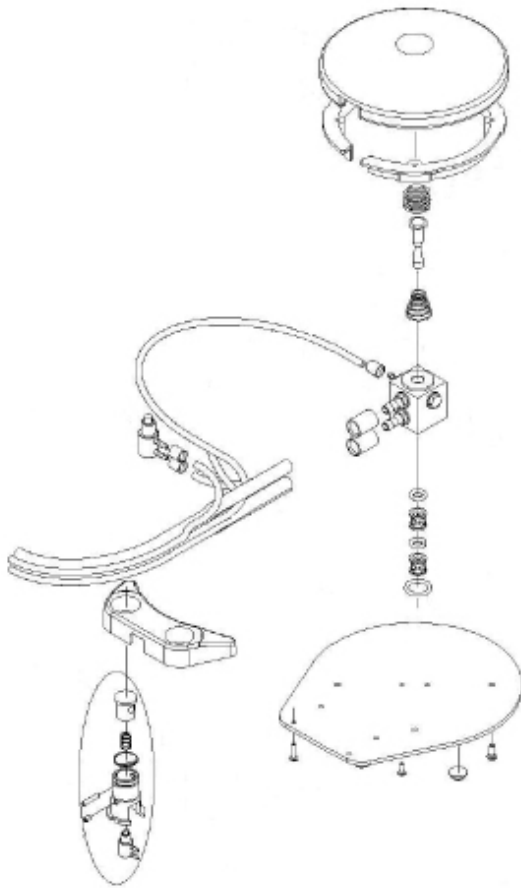

WATER COOLANT

ADDING WATER TO DENTAL SYSTEM

Slowly remove water bottle from pressure manifold assembly and add distilled water only. Leave approximately two inches of air space at the top. Replace bottle, tighten until secure.

AIR / WATER SYRINGE

All of our dental stations come with an air / water syringe installed and ready to use. Depress the left button for water only. Depress the right button for air only. Depress both buttons to get a mist spray.

MAINTENANCE OF THE DENTALAIRE DENTAL SYSTEMS

COMPRESSOR

Oil Change: Please change the oil in the compressor once a year. To change the oil, you want to start by taking the compressor out of the Cart Frame, unplugging the black power cord and main Air line then remove the white cover off of the compressor by removing the six bolts at the bottom. Now tilt the compressor away from you and unscrew the site glass indicator. Tip the compressor forward and pour the oil into a small bucket or coffee can. Next screw the site glass back on. Put the white cover back over the compressor and screw in the six bolts.

Please refer to our Compressor Maintenance Guide Chart below to help you keep the compressor running in top form.

COMPRESSOR MAINTENANCE GUIDE CHART

Maintenance Procedure	Daily	Weekly	Monthly	Annually
Purge Drain	X			
Vent Moisture Trap		X		
Check Oil Level			X	
Clean Air Filter Intake				X
Change Oil				X
Complete Check of System				X

SERVICE AND MAINTENANCE LOG

Service Performed	Date	Serviced By
1. Initial Installation		

AIR / WATER SYRINGE

Air or water leakage from the syringe is due to either worn or defective O-Rings or button assemblies.

To rebuild syringe first remove the pin on the side of the housing, and then simply pull out the button straight out of the syringe head. Remove all water deposits off buttons & cylinders. Lubricate the buttons with a non-petroleum based lubricant. Reinstall the Air/Water buttons. Reinsert the pin through housing. Syringe Rebuild Kit Item # A113-403

ORAL ILLUMINATION

This refers to the high speed handpieces that have a fiber-optic system. This unit will periodically require a change in the Halogen Light Bulb. Here's how to change the bulb:

1. Please make sure you are wearing gloves (before) handling the new bulb. The oils from your body will ruin the new halogen bulb.
2. Slide both sleeves back from the connector nut exposing bulb on side of housing.
3. Remove old bulb.
4. Install new bulb.
5. Place bulb back into housing
6. Slide sleeve over housing..
7. Reinstall high speed handpiece.

Parts-List of the Series "SIL Air"

C0004	Clip for Terminal Bloc	C0110	Capacitor 230V 53-64 MFD T 2134
C0011	Filter Air Intake	C0111	Overload Protector 230V T 2134
C0026	Gauge Pressure M1/8" 10 bar d=40mm	C0112	Relay Starting 230V T 2134
C0034	Strain Relief	C0113	Bolt
C0037	Bolt M6x20mm UNI 5931	C0114	Nut M8 UNI 5589
C0039	Washer 5.3x10mm UNI 6592	C0115	Gasket Exhaust-Valve T 2134
C0040	Fitting Reduction M1/4"-F 1/8"	C0116	Valve Plate cpl. T 2134
C0043	Bolt TE M6x10mm DIN 934	C0117	Gasket Intake-Valve T 2134
C0044	Handle Mod. 1080 135mm	C0120	Washer flat 6x24mm UNI 6593
C0045	Cable Electric 230V 600mm	C0124	Valve Safety 8 bar M1/4"
C0046	Valve Check M-F 1/8"	C0126	Foot Rubber
C0047	Fitting M5 d=6mm	C0136	Frame i Support 50/15A
C0048	Switch Pressure 4-P 230V	C0137	Tank 16lt 50/15A
C0049	Plug M 1/4"	C0138	Drain Cook M1/4"
C0051	Hose Nylon 6/4	C0144XX	Tank 50-9D
C0051	Bolt M8x15mm	C0150	Fitting "L" M1/8"-F 1/8"
C0062	Washer M10x20mm UNI 6592	C0151	Fitting Nipple M1/4"-M1/4" 60mm
C0063	Fitting "L" M1/4"-F 1/8"	C0154	Washer Aluminum d=6mm 2X10
C0064	Hose Air M1/8"xF 1/4" 170mm	C0156	Fitting Manifold 4F 1/4"-1xF 1/8"
C0065	Fitting "L"-rotating M1/4"x6.3mm	C0164	Filter Regulator WI
C0067	Bolt TE M8x35mm UNI 5739	C0164-1	Pressure Bowl WI
C0068	Power Cord 230V Euro-Plug	C0164-2	Filter Element WI
C0073	Hose Air M1/8"xF 1/4" 235mm	C0164-4	Filter Regulator SMC
C0076	Fitting "L" M1/4"-F 1/4"	C0164-5	Pressure Bowl SMC
C0077	Fitting Swivel Connector M1/4"	C0164-6	Filter Element SMC
C0081	Handle Rubber	C0164-7	Washer for Filter SMC
C0082	Switch Pressure 1-P Condor	C0171	Kit for Grounding
C0083	Fitting M1/4" 90mm	C0180	Power Cord 115V American Plug
C0088	Gauge Pressure 1/8" rear	C0200	Switch Pressure 1-P 230V
C0089	Fitting M1/4" M1/4" 95mm	C0202	Valve Head Pressure Release
C0091	Cable Electric 230V 500mm	C0205	Fitting Reduction M1/4"-F 1/8"
C0092	Fitting "T" M-F-F 1/4"	C0222	Pump Compressor 230V T 2134
C0093	Cover for Terminal Bloc	C0272	Check Valve 100/24
C0094	Foot Rubber	C0284	Pump Compressor 115V T 2134A
C0097	Foot Rubber	C0286	Washer 8.5x15mm UNI 3703
C0099	Screw M6x20mm UNI 5739	C0305	Kit Terminal-Bloc 230V T 2134
C0100	Washer M6	C0306	Kit for Spring-Clamp
C0101	Closing Band	C0308	Kit Motor-Parts 230V cpl. T21
C0102	Cap Plastic Transparent	C0309	Bolt for Cover T21
C0103	Gasket Housing	C0310	Pressure-Pipe T21
C0105	Bolt M8x30mm	C0311	Gasket Pressure-Pipe T21
C0106	Spacer T 2134	C0312	Bolt to Top-Bearing
C0108	Terminal-Bloc	C0313	Bearing Top T21
C0109	Bracket for Capacitor	C0314	Spring for Suspension T21
C0315	Cover T21	C0335	Capacitor 115V
C0316	Gasket to Cover T21	C0339	Nylon Tube D8/6
C0317	Overload Protector 115V T 2134	C0340	Switch Pressure 4-P 115V
C0320	Bolt to Mount Slaton T21	C0349	Spring for Overload
C0321	Stator 230V T21	C0354	Drain-Cook tanktop 15lt
C0322	Kit Motor-Parts 230V T2134 cpl. w/o Housing	C0356	Tube Plastic 6/4 blue
C0323	Valve Intake T 2134	C0357	Fitting "L"-F 1/8"-F 1/8"
C0324	Valve Exhaust T 2134	C0358	Oil-Level Indicator 1/2" Metal Frame
C0325	Relay Starting 115V T 2134	C0394XX	Tank 50-6
C0331	Kit Motor-Parts 115V cpl. T21	C0437XX	Tank 24lt 100/24 10CE D200
C0332	Stator 115V T21	C0451	Cable Electric 115V 600mm
C0333	Kit Terminal-Bloc 115V T 2134	C0458XX	Pump Compressor 115V T 2134
C0338	Capacitor 115V	C0461XX	Housing 50-9D
C0339	Nylon Tube D8/6	C0509	Fitting "L" M1/4"-F 1/4"
C0340	Switch Pressure 4-P 115V	C0516	Fitting Reduction M3/8"-F 1/4"
C0349	Spring for Overload	C0517	Plug Drain M 1"
C0354	Drain-Cook tanktop 15lt	C0522	Washer 1"
C0356	Tube Plastic 6/4 blue	C0567	Fitting Nipple M1/8"-M1/8"
C0357	Fitting "L"-F 1/8"-F 1/8"	C0563	Foot Rubber d=25mm
C0358	Oil-Level Indicator 1/2" Metal Frame	C0643	Valve Head Pressure Release
C0394XX	Tank 50-6	C0659	Bolt TC M5x14mm
C0437XX	Tank 24lt 100/24 10CE D200	C0661	Nut M5 UNI 5567
C0451	Cable Electric 115V 600mm	C0685	Wheel Rubber d=80x25mm
C0458XX	Pump Compressor 115V T 2134	C1094XX	Tank 24lt 50/24
C0461XX	Housing 50-9D	C1089	Oil-Level Indicator Plastic 1/2"
C0509	Fitting "L" M1/4"-F 1/4"	C1100	O-Ring T21
C0516	Fitting Reduction M3/8"-F 1/4"	C1235	Kit Valve Plate T 2134 cpl. with Gaskets
C0517	Plug Drain M 1"	R0103	Bolt M8
C0522	Washer 1"	R0153	Bolt M8x25mm UNI 5739 ZN
C0567	Fitting Nipple M1/8"-M1/8"		
C0563	Foot Rubber d=25mm		
C0643	Valve Head Pressure Release		
C0659	Bolt TC M5x14mm		
C0661	Nut M5 UNI 5567		
C0685	Wheel Rubber d=80x25mm		
C1094XX	Tank 24lt 50/24		
C1089	Oil-Level Indicator Plastic 1/2"		
C1100	O-Ring T21		
C1235	Kit Valve Plate T 2134 cpl. with Gaskets		
R0103	Bolt M8		
R0153	Bolt M8x25mm UNI 5739 ZN		

T2134A 230V - 50HZ
115V - 60HZ

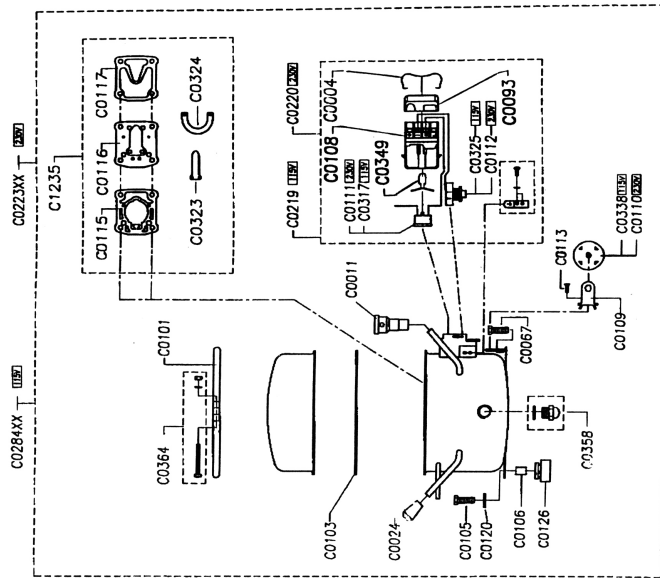

DA400FOB - Fiber-optic Halogen Replacement Bulb

Changing bulb on High-speed Handpiece

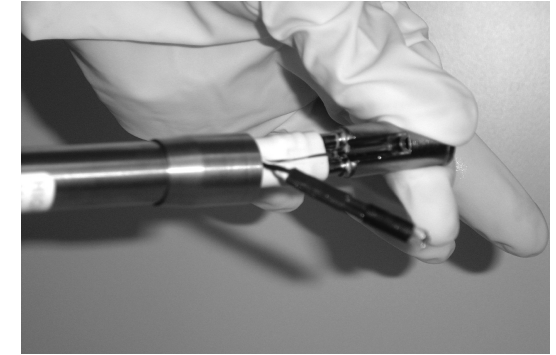

TRUBLE SHOOTING GUIDE

I. NO COOLANT WATER

1. Water bottle empty.
2. Flow control knob is closed.
3. On / Off toggle is off.
4. High speed handpiece is in the low speed position
5. Faulty water relay valve.
6. Plugged coolant port in handpiece

II. COOLANT WATER DOES NOT SHUT OFF

1. Faulty water relay valve.
2. Water On / Off toggle left on

III. COOLANT WATER LEAKING FROM HANDPIECE

1. Missing or damaged handpiece connector gasket.
2. Faulty water relay valve.
3. Slow speed handpiece is in the high speed position.

IV. MORE THAN ONE HANDPIECE RUNS AT THE SAME TIME

1. Handpieces are not positioned all the way down in the holders.
2. Faulty auto block diaphragm.

V. AIR / WATER SYRINGE PROBLEMS

1. Water drips from tip.
 - a) Faulty valve core
2. Button blow out.
 - a) Tip is plugged at the end.

SIL AIR 50-9 D

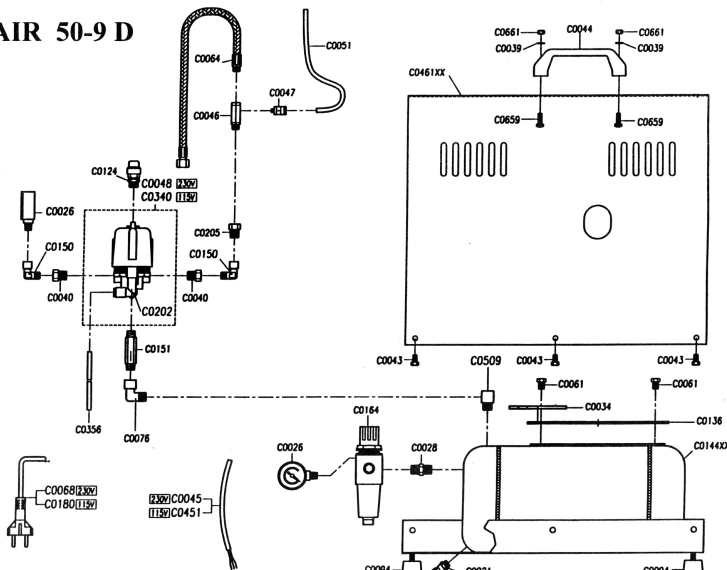

- b) Tip is not installed all the way into the into the Air Water Sprayer. (Loosen nut, press tip further into connector and tighten nut while holding the tip in)
- c) Faulty o-ring in tip adapter.
- 3. Air or water leaks from buttons when in use.
 - a) Faulty buttons.
- 4. Low air or water flow cont:
 - a) Improper regulator adjustment
 - b) Empty water bottle
 - c) Kinked supply tubing.
 - d) Plugged tubing.
 - e) Plugged syringe head

VI. FOOT CONTROL HISSES

1. Faulty foot control popped valve.
2. Foot control tubing connected backwards.

VII. HANDPIECE TUBING BLOWS OFF

1. Handpiece has been over pressurized.

VIII. COMPRESSOR WON'T TURN ON

1. Check power source. Check tank pressure (compressor will not turn on if tank is fully pressurized).
3. Faulty starting capacitor (replace).
4. Compressor is over-heated and the thermal safety switch is off. (Let unit cool and it will come on automatically, usually in 20 - 30 minutes).

IX. HANDPIECE LACKS POWER

1. Inadequate tank pressure.
2. Improper regulator pressure (reset regulator).
3. Improper individual handpiece pressure adjustment.
4. Faulty foot control.
5. Handpiece connector gasket is missing.
6. Directional selector ring is not rotated all the way into forward or reverse. (Slow speed handpiece only)
7. Faulty handpiece tubing.

X. COMPRESSOR RUNS, BUT WON'T PRESSURIZE FULLY

1. Plug is on the air inlet. Replace with air filter.
2. Compressor tank drain valve is leaking air.
3. Faulty check valve between compressor and filter tank.

XI. COMPRESSOR OVERHEATS

1. Air inlet is plugged.
2. Handpiece pressure is set too high.

3. Handpiece has been run for too long a time and the 50% duty cycle has been exceeded.

XII. UNIT IS PRESSURIZED BUT HANDPIECE DOES NOT RUN

1. Regulator pressure is low or off.
2. Supply tubing from regulator to control head is kinked.
3. Faulty foot control.
4. Handpiece directional ring is between forward and reverse (slow speed handpiece only).
5. Faulty handpiece turbine.

TROUBLE SHOOTING GUIDE FOR BUILT IN AMDENT PIEZO SCALER

I. THE SCALER WON'T RUN

1. Check main power , main fuse, On / Off Switch.

II. WEAK OR NO TIP VIBRATION

1. Increase the power control setting.
2. Check to see if tip is tightened properly.
3. The tip is worn out, replace with new tip.
4. Change to a new handpiece.
5. Faulty air switch.
6. Change back to the old handpiece and then replace the electronic part.
7. Replace both the handpiece and electronic part.

III. INSUFFICIENT WATER SPRAY

1. Turn the knob to full open position.
2. Check / replace water filter.
3. Check all water connections. Be sure there is no leakage or kinked tubing.
4. Remove the tip, if the water is dripping from the handpiece, replace the tip.
5. Check the delivery unit's control block that activates the water out to the scaler handpiece is working properly.

FOOT CONTROL TO ULTRASONIC "PIEZO" SCALER

This foot pedal has two buttons, one large and one small. The large button is for operating the high and low speed handpieces. The small button is for operating the piezo scaler only.

