

## End View

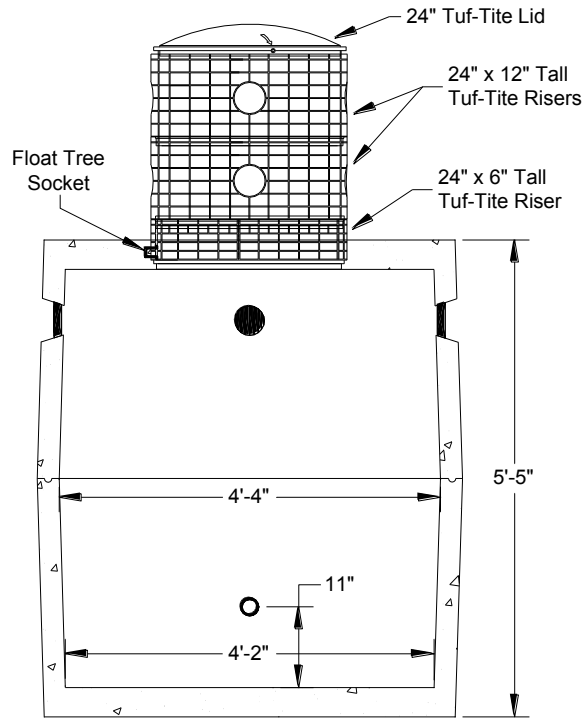

## Cross Section

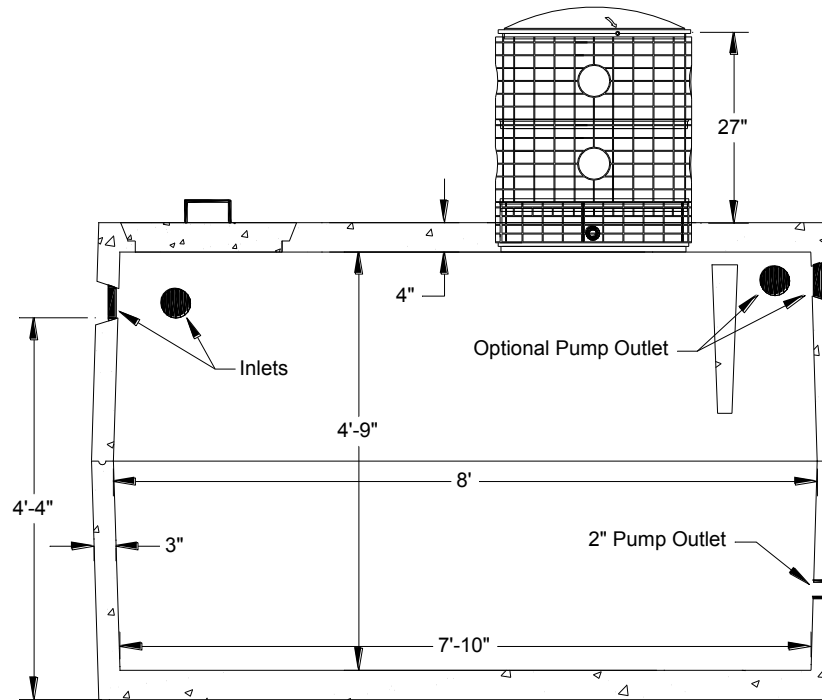

## SPECIFICATIONS

**Tank:** Manufactured per Montana Circular DEQ-4 Chapter 7 design standards for septic tanks, 4" dia. Pipe seals for inlet pipe penetrations, 1 EA 20" cleanout lid, 1 EA 24" dia. x 6" Tuf-Tite riser cast into tank lid for pump access, 1 EA 2" Sch40 PVC coupler cast in tank wall for pump outlet.

**Standard Components:** 2 EA 24" dia. x 12" tall Tuf-Tite access riser extensions, 1 EA 24" Tuf-Tite lid, SS screws, ConSeal CS-102 butyl rubber sealant to seal tank joint.

**NOTE 1):** Tank must be installed per Billings Precast's 'Tank Installation Guide' or warranty will be VOID.

**NOTE 2):** Tank shall **not** be placed in a traffic area (ie. parking lot, driveway, etc.) - Warranty will be VOID if driven on.

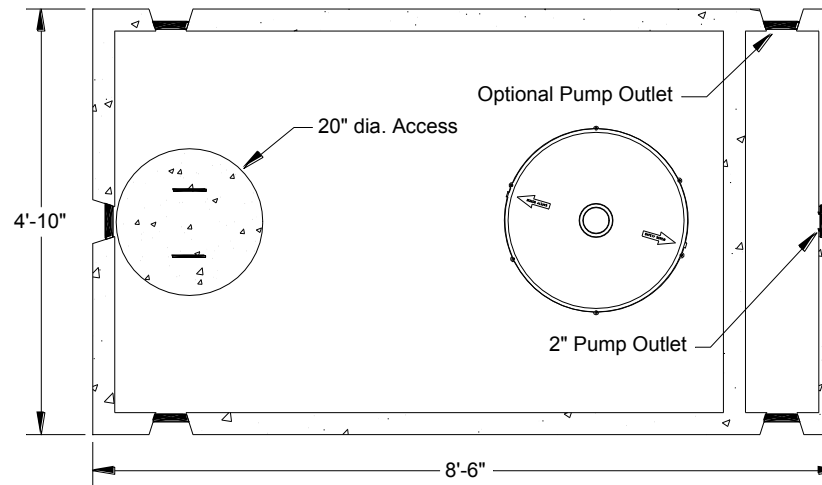

## Top View

WEIGHTS: 4000 lb. per 1/2 [ Total = 8000 lb. ]

**BILLINGS PRECAST**  
 CONCRETE RESULTS FOR HARD WORKING PEOPLE

5815 Interstate Avenue, Billings, Montana 59101  
 PH (406) 656-6098 FAX (406) 656-4942  
 www.billingsprecast.com

DWG. NO. **DT10**

1000 Gal Dosing Tank

SCALE: NONE  
 DATE: 7-13-12  
 REV: DRN: WDB