

CUSTOM-BURR®

**DUAL
FUNCTION**

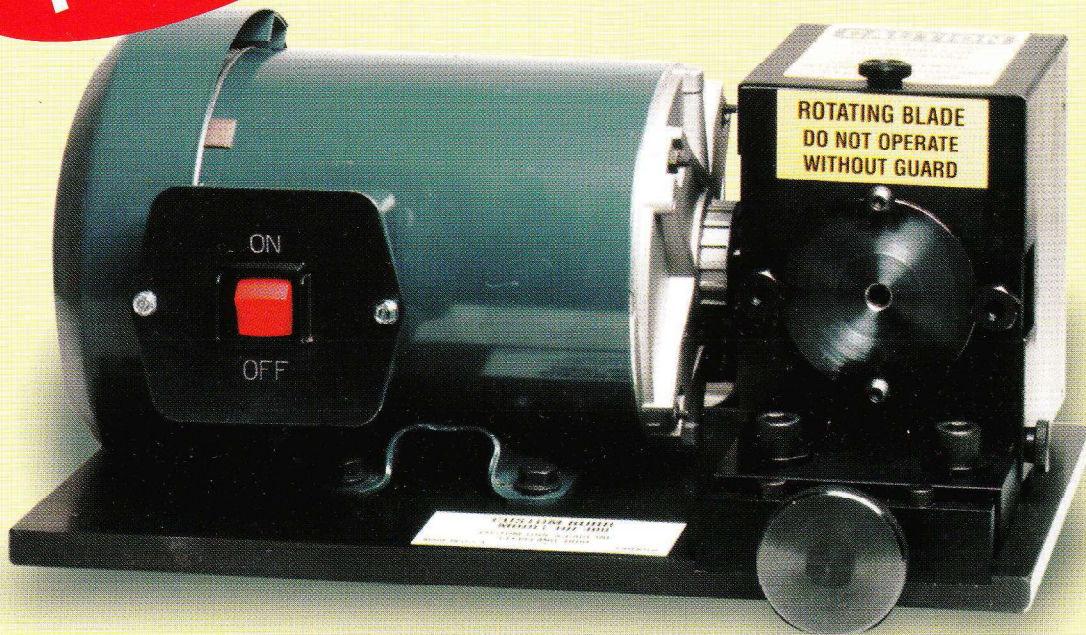

MODEL HH-400

Made in U.S.A.

Patented

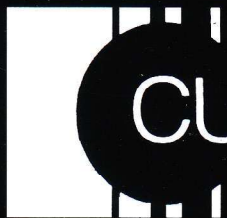

Manufactured by

CUSTOM TOOL & GAGE^{CO}

5765 CANAL ROAD ■ CLEVELAND, OH 44125

1-800-354-3543

216-447-0860



FAX 216-447-0381



Email: TOOLNGAGE@AOL.COM

CUSTOM-BURR®

CUSTOM-BURR® is designed specifically to remove cut-off burrs accurately and efficiently. Burrs are cut cleanly, without smearing, to exacting standards. As a bonus...CUSTOM-BURR® can also slot!



CAPABILITIES

DEBURR and/or SLOT

- Use for Metal or Plastic parts
- Do Round, Hexagon, Square, or Odd shapes
- Able to do Stubby parts
- Burrs are Milled Off
- Ideal for Tough Materials
- Deburr — Above, Flush, or Below surface



Before Deburr



After Deburr



Slot

**Fast — Perfect Part Everytime
Ideal for Screw Machines, CNC
Turning Centers, and Molded Parts.**

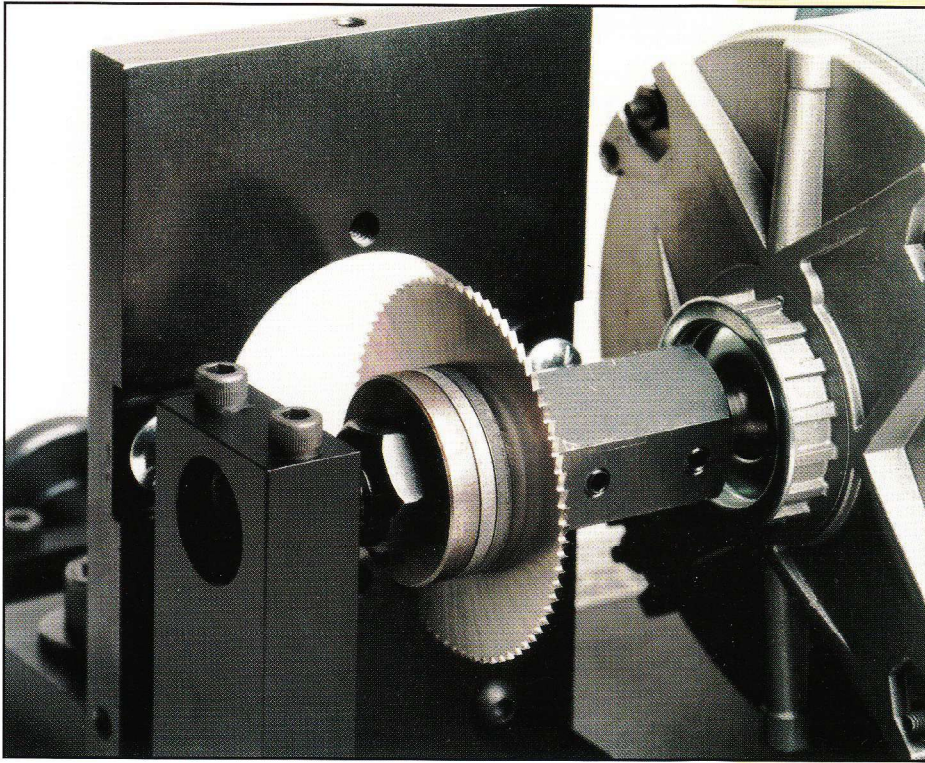

Cutter supported between motor bearing and outboard ball bearing support.

FEATURES

Positive Steel Stop

- Accurate —Consistent
- Part length unaffected
- Reversible
- Machinable for special applications

Permanent Lock Down

- Adjustment stays fixed

Non-cantilevered Shaft Design

- Minimizes deflection and bearing wear
- Provides outstanding rigidity

Built for the Industrial Environment

- Heavy-duty all metal construction

Fast — High Output

- Long or short runs

Easy Cutter Adjustment

- Change saw thickness or location on shaft
- Simple adjustments
- Quick changeover

Work Bushing

- Reworkable to accommodate different part sizes
- Up to 2" capacity

Ample Chip Clearance

Portable Unit

- Tabletop or stand alone
- Use in work cells

SAFETY FEATURES

Steel Cover

- Completely encloses cutter
- No flying chips

Guarded and Lighted on/off switch

CONSIDER THESE FACTS

- **Low initial cost**
- **Low operating cost**
- **Does not require skilled operator**
- **Utilize idle time during primary machine cycle**
- **Easy initial set-up**
- **Portable, tabletop unit fits easily into work cells**
- **Eliminate rejects caused by grinding or sanding**
- **High output for long or short run production**
- **Low cost saw blade replacement**
- **No special fixtures required**
- **Maintenance Free**

After initial set-up, no further machine adjustment is usually required. To run a different part, just change the work bushing & begin deburring.

CUSTOM-BURR®

MODEL HH-400
SPECIFICATIONS



OVERALL DIMENSIONS
14½" L x 9½" W x 7½" H

ELECTRICAL
115V 1ø 60c

CAPACITY
Up to 2" round

CUTTER
#15 HSS Screw Slotting saw supplied as standard
(2¾" O.D. x 1" bore x .057 wide)

SHIMS
Standard assortment — 1½" O.D. x 1" I.D.

STEEL WORK BUSHING
2 Supplied with machine

MACHINE WEIGHT
45 lbs.

SHIPPING WEIGHT
50 lbs.

NO ACCESSORIES REQUIRED

Manufactured by

CUSTOM TOOL & GAGE_{CO}

5765 CANAL ROAD ■ CLEVELAND, OH 44125

1-800-354-3543

216-447-0860

■ FAX 216-447-0381

■ Email: TOOLNGAGE@AOL.COM

EXAMPLES

C'Bore or Slot Bushing for additional chip clearance and/or saw clearance

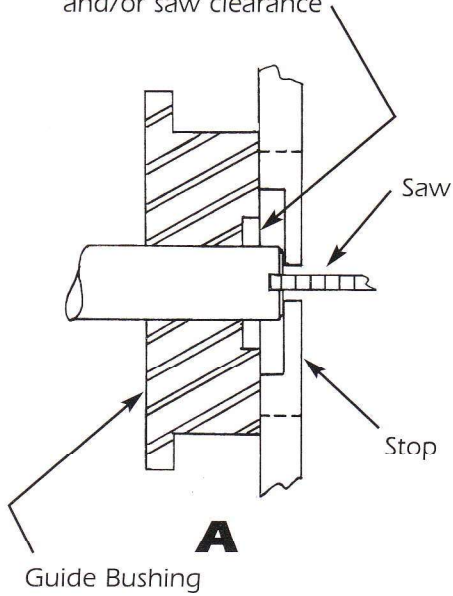

Machined cavity (on or off centerline) for shaped parts.

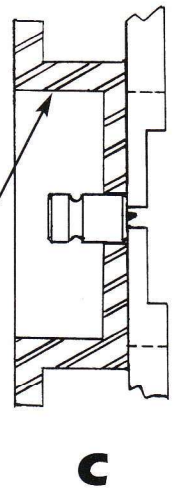
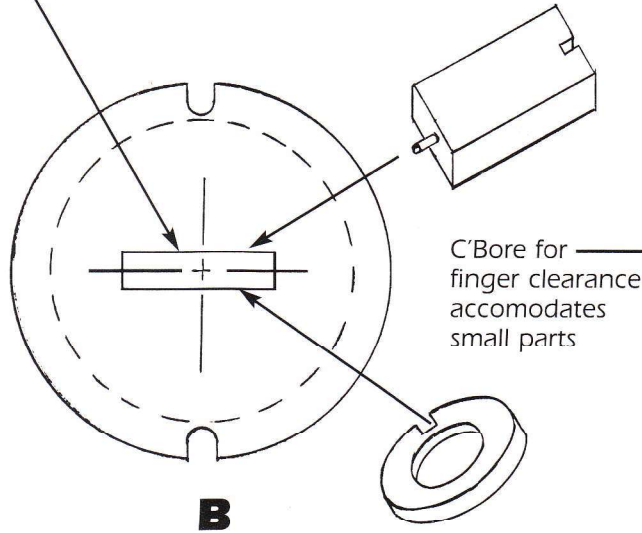

Carrier Bushing for shouldered parts

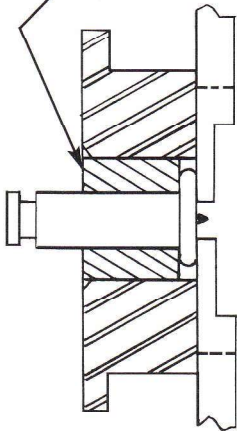

Locators can be fitted to front of work bushing.

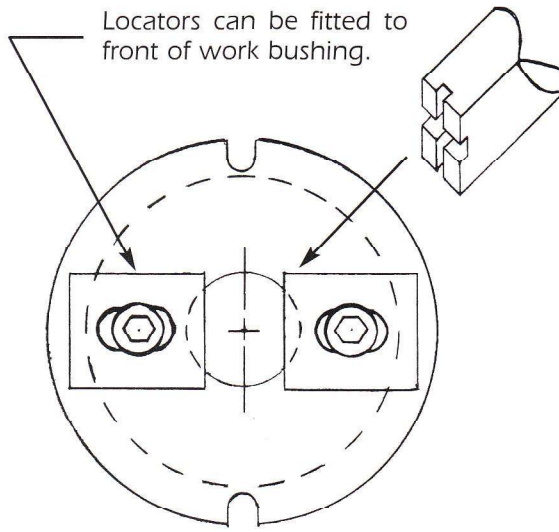

C'Bore to accomodate short locating diameter

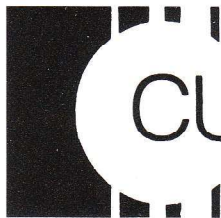
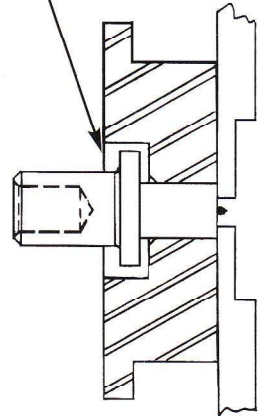

Manufactured by

CUSTOM TOOL & GAGE CO

5765 CANAL ROAD ■ CLEVELAND, OH 44125

1-800-354-3543

216-447-0860



FAX 216-447-0381



Email: TOOLNGAGE@AOL.COM