

零件样本
PARTS BOOK

目录/CONTENTS

A. 机体部分 / Machine body	1
B. 上轴、针杆装置 / Upper shaft and needle bar mechanism	3
C 1. 送料装置 / Feed mechanism	5
C 2. 送料装置 / Feed mechanism	7
C 3. 送料装置 / Feed mechanism	11
C 4. 送料装置 / Feed mechanism	13
D 1. 抬压装置 / Work clamp lifter mechanism	15
D 2. 抬压装置 / Work clamp lifter mechanism	17
D 3. 抬压装置 / Work clamp lifter mechanism	19
E. 下轴装置 / Lower shaft mechanism	21
F. 供油润滑装置 / Lubrication	23
G. 穿线装置 / Threading mechanism	27
H. 卷线装置 / Bobbin winder mechanism	29
J. 切线装置 / Thread trimmer mechanism	31
K. 扫线装置 / Thread wiper mechanism	35
L. 松线装置 / Tension release mechanism	37
P. 空压装置 / Air pressure mechanism	39
Q. 电气部品装置 / Power supply equipment mechanism	41
S. 马达装置 / Motor mechanism	43
T. 踏板关系 / Foot switch pedal mechanism	45
Z. 附件 / Accessories	47
Ga. 工模具一览表 / Gauge parts list	51

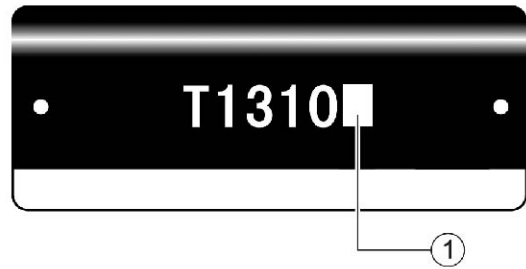

- ① — S: 电磁式抬压脚 / Solenoid-type work clamp lifter
A: 空压式抬压脚 / Pneumatic-type work clamp lifter



A. 机体部分 / Machine body

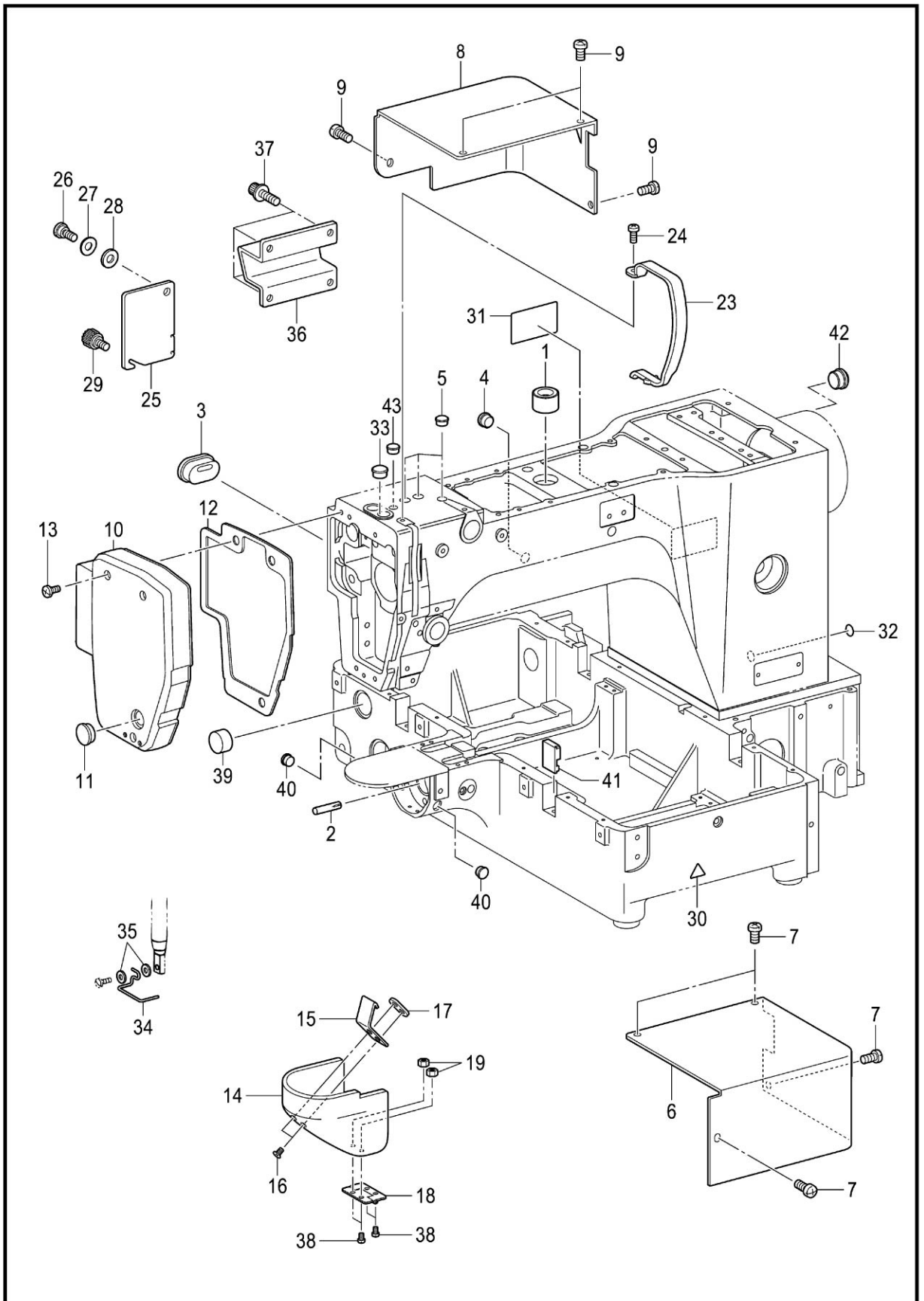

A、机体部分/Machine body

序号 No.	件号 Part. No.	参考件号 Ref. No.	零部件名称	NAME OF PARTS	数量 Amt.	备注
1	41703001	SA4594001	轴套 U	BUSHING U	1	T1310
2	41729001	117608001	开口销	DOWEL PIN	1	
3	41722001	SA4596001	橡皮塞 20-15	RUBBER CAP 20-15	1	
4	41722002	117934001	橡皮塞 13.5	RUBBER CAP, 13.5	1	
5	41722003	104821001	橡皮塞 10.5	RUBBER CAP, 10.5	3	
6	41711050	SA4597001	马达盖 R	MOTOR COVER R	1	
7	S04038	062061016	螺钉 M6×10	SCREW PAN M6×10	4	
8	41711051	SA4598001	马达盖 L	MOTOR COVER L	1	
9	S04038	062061016	螺钉 M6×10	SCREW PAN M6×10	4	
10	41701001	SA4600001	面板	FACE PLATE	1	
11	41722004	104449001	橡皮塞 15.5	RUBBER CAP, 15.5	1	
12	41712003	SA4601001	面板垫片	F-PLATE PACKING	1	
13	S04038	062061016	螺钉 M6×10	SCREW PAN M6×10	3	
14	41712004	SA4603101	大旋梭盖	SHUTTLE RACE COVER	1	
15	41712005	SA6272001	大旋梭盖挂钩 D	SHUTTLE RACE COVER HOOK D	1	
16	S02031	004300513	螺钉 M3×5	SCREW, PLAT M3×5	2	
17	41712006	SA3264001	板螺母	NUT PLATE	1	
18	4171220200	SA6207001	铰链	HINGE	1	
19	N01013	021300103	螺母 M3	STEPPING COVER	2	
23	41712007	SA3200101	挑线杆防护罩	THREAD TAKE-UP COVER	1	
24	S04079	062401006	螺钉 M4×10	SCREW PAN M4×10	1	
25	41712008	SA4604001	间歇盖板	STEPPING COVER	1	
26	417S30012	SA3306001	段螺钉 7-3	SHOULDER SCREW, 7-3	1	
27	41728020	120265002	弹簧垫圈	SPRING WASHER	1	
28	41728035	S07350002	垫圈	WASHER PLAIN	1	
29	41711005	S36475000	螺钉 M5	SCREW, M5	1	
30	41737001	S36924001	警告标记	MARK, INJRY	1	
			<用于日本>	<For Japan only>		
31	41737002	SA2040001	操作注意标签 (日/英)	LABEL, CAYTION JPN/END	1	
			<用于日本以外>	<For Except Japan>		
31	41737003	SA2040001	操作注意标签 (中/英)	LABEL, CAYTION CHN/END	1	
32	41737004	S37060001	接地标记	LABEL, GROUNDING	1	
33	41722009	S20164001	橡皮塞 13	RUBBER CAP, 13	1	
34	41712009	S02445001	护指器	FINGER GUARD	1	
35	41728025	025350332	平垫圈 L3.5	WASHER PLAIN L3.5	2	
36	41712010	SA4605001	机头撑杆	HEAD REST	1	
37	417S30037	S42446001	螺栓 M6×14	BOLT, SOCKET (S/P WASHER) M6×14	4	
38	S04075	062300506	螺钉 M3×5	SCREW PAN M3×5	4	
39	41722006	SA6194001	橡皮塞 26	RUBBER CAP 26	1	
40	41722007	S44010001	橡皮塞 11.5	RUBBER CAP 11.5	2	
41	41722008	SA6441001	橡皮盖	RUBBER CAP	2	
42	41722009	S20164001	橡皮塞 13	RUBBER CAP 13	1	
43	41722013	104450101	橡皮塞 8	RUBBER CAP 8	2	

B. 上轴 · 针杆装置 / Upper shaft and needle bar mechanism

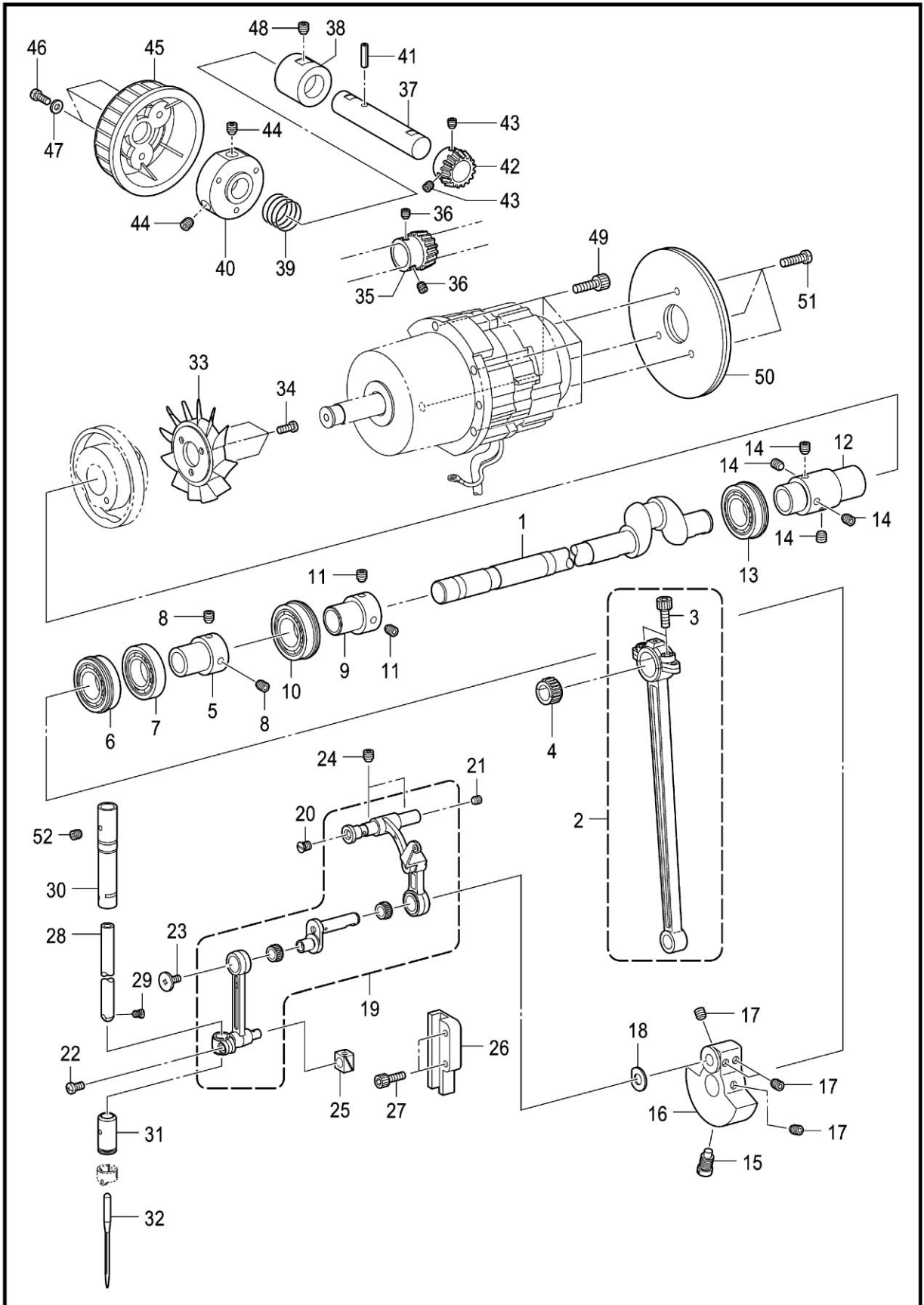

B、上轴·针杆装置/Upper shaft and needle bar mechanism

序号 No.	公司件号 Part. No.	参考件号 Ref. No.	零部件名称	NAME OF PARTS	数量 Amt.	备注
1	41702001	SA4606001	上轴	UPPER SHUFT	1	
2	4170501100	SA3499001	曲柄轴组件	CRANK ROD ASSY	1	
3	S05124	018501636	螺栓 M5×16	BOLT SOCKET M5×16	2	
4	41724001	SA4172001	滚针轴承 K15×18×14	NEEDLE BEARING:BLUE	2	
4	41724001	SA4173001	滚针轴承 K15×18×14	NEEDLE BEARING:BLACK	2	
4	41724001	SA4174001	滚针轴承 K15×18×14	NEEDLE BEARING:GRAY	2	
4	41724001	SA4175001	滚针轴承 K15×18×14	NEEDLE BEARING:YELLOW	2	
5	41703002	SA3206001	轴承套	BALL BEARING BUSH	1	
6	B10014	SA4179001	轴承 6904DDUNR	BALL BEARING 6904DDUNR	1	
7	B06005	SA4180001	轴承 R-6904DDU	BALL BEARING 6904DDU	1	
8	S10018	S23651001	固定螺钉 M6×0.75-6	SET SCREW SOCKET(FT)M6×6	2	
9	41703002	SA3206001	轴承套	BALL BEARING BUSH	1	
10	B10012	SA4177001	轴承 6004DDUNR	BALL BEARING 6004DDUNR	1	
11	S10018	S23651001	固定螺钉 M6×0.75-6	SET SCREW SOCKET(FT)M6×6	2	
12	41703004	SA4608101	管接头 G	JOINT G	1	
13	B10013	SA4178001	轴承 6204DDUNR	BALL BEARING 6204DDUNR	1	
14	S10018	S23651001	固定螺钉 M6×0.75-6	SET SCREW SOCKET(FT)M6×6	4	
15	417S30002	S25235001	螺钉 M8	SCREW, M8	1	
16	41704001	SA4609101	针杆曲柄 G	THREAD TAKE-UP CRANK G	1	
17	S10018	S23651001	固定螺钉 M6×0.75-6	SET SCREW SOCKET(FT)M6×6	4	
18	41712133	110367001	垫圈 8	WASHER, PLAIN SPECIAL 8	1	
19	4170501200	SA6182001	针杆连杆组件 FK	THREAD TAKE-UP LEVER FK SET	1	
20	417S17003	SA2958001	螺钉 M5×6	SCREW FLAT M5×6	1	
21	S09019	012500536	螺钉 M5×5	SET SCREW SOCKET(FT)M5×5	1	
22	S04078	062400816	螺钉 M4×8	SCREW PAN M4×8	1	
23	417S14001	145465001	螺钉 SM3. 57-40×6L	SCREW SM3. 57-40×6L	1	
24	S10019	012060636	螺钉 M6×6	SET SCREW SOCKET(FT)M6×6	1	
25	41709001	142211001	滑块	SLIDE BLOCK	1	
26	41709002	SA3528001	滑块导向 B	SLIDE BLOCK GUIDE	1	
27	S05118	018401636	螺栓 M4×16	BOLT SOCKET M4×16	2	
28	41702002	SA4622001	针杆	NEEDLE BAR	1	
29	417S15002	144458001	螺钉 SM3. 57-40×4.5	SET SCREW, SM3. 57-40×4.5	1	
30	41703005	SA4666001	针杆轴套 UK	NEEDLE BAR BUSH UK	1	
31	41703006	SA3224001	针棒轴套 D	NEEDLE BAR BUSH D	1	
32	40319006	*P. 67	机针	NEEDLE	1	
33	12411002	S38713100	叶轮	FAN	1	
34	S04078	062400816	螺钉 M4×8	SCREW PAN M4×8	3	
35	40325010	SA6108001	齿轮 R	PULLEY GEAR R	1	
36	S09019	012500536	螺钉 M5×5	SET SCREW SOCKET(FT)M5×5	2	
37	41702003	SA4626001	上轮轴	PULLEY SHUFT	1	
38	41703007	SA4627001	上轮轴套	PULLEY BUSH	1	
39	41727001	SA4628001	上轮弹簧	PULLEY SPRING	1	
40	41703008	SA4629001	上轮基座	PULLEY BASE	1	
41	P03027	047401242	弹簧销 4×12	PIN SPRING ROLL AW4	1	
42	41725002	SA4624001	齿轮	PULLEY GEARL	1	
43	S09019	012500536	螺钉 M5×5	SET SCREW SOCKET(FT)M5×5	2	
44	S10018	S23651001	固定螺钉 M6×0.75-6	SET SCREW SOCKET(FT)M6×6	2	
45	41711001	SA4630001	上轮	PULLEY	1	
46	S04079	062401006	螺钉 M4×10	SCREW PAN M4×10	3	
47	41728024	SA5158001	垫圈 L4	WASHER PLAIN L4	3	
48	S10019	012060636	螺钉 M6×6	SET SCREW SOCKET(FT)M6×6	1	
49	S05124	018501636	螺栓 M5×16	BOLT SOCKET M5×16	4	
50	41712011	SA5230001	惯性轮 2	FRIES WHEEL 2	2	
51	417S30021	062401016	螺钉 M4×10	SCREW PAN M4×10	3	
52	S09041	012060536	螺钉 M6×5	SET SCREW SOCKET(FT)M6×5	1	

C1 . 送料装置 / Feed mechanism

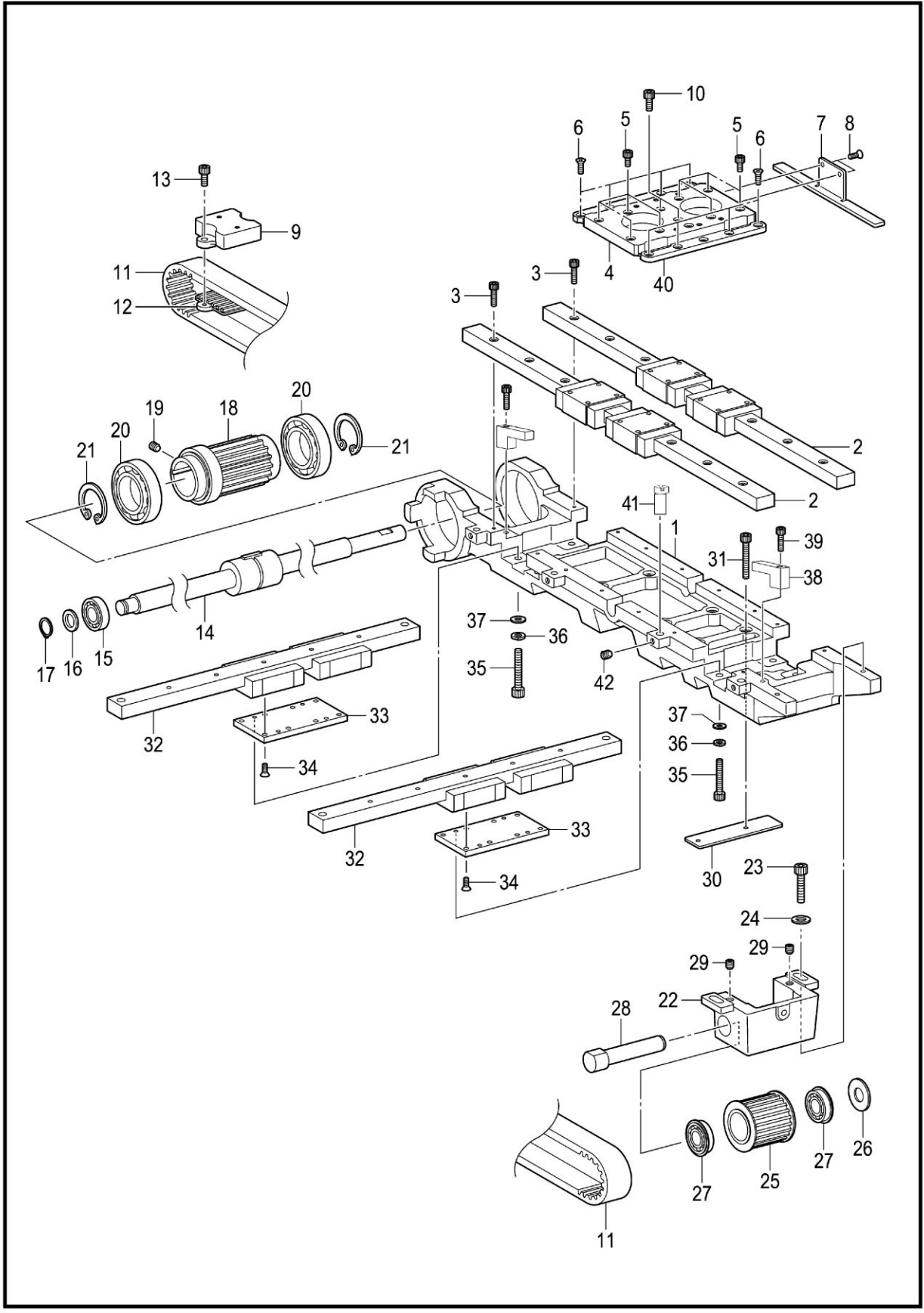

C1、送料装置/Feed mechanism

序号 No.	公司件号 Part. No.	参考件号 Ref. No.	零部件名称	NAME OF PARTS	数量 Amt.	备注
1	41701002	SA5229101	送布基座组件	FEED BRACKET ASSY	1	
2	41724006	SA4637001	X-LM 导向	X-LM GUIDE	2	
3	S05114	018301436	螺栓 M3×14	BOLT SOCKET M3×14	15	
4	41701003	SA4635101	送布台 (X)	FEED BRACKET X	1	
5	S05113	018300636	螺栓 M3×6	BOLT SOCKET M3×6	8	
6	S02032	061300616	螺钉 M3×6	SCREW FLAT M3×6	8	
7	41709004	SA4636101	传感器板 (X)	X-SENSOR PLATE	1	
8	S02032	061300616	螺钉 M3×6	SCREW FLAT M3×6	2	
9	41709005	SA4641001	皮带支架	X-BELT HOLDER	1	
10	S05116	018400836	螺栓 M4×8	BOLT SOCKET M4×8	2	
11	41735001	SA4649001	X-GT 皮带	X-GT BELT	1	
12	41712012	SA4640001	皮带支架板 (X)	X-BELT HOLDER PLATE	1	
13	S05116	018400836	螺栓 M4×8	BOLT SOCKET M4×8	2	
14	41702004	SA4639001	花键轴 (Y)	Y-BALL SPLINE	1	
15	B06006	076000600	球轴承 6000VV	BALL BEARING RADIAL 6000W	1	
16	41728001	S20356001	平垫圈 10	WASHER PLAIN 10	1	
17	H03008	048100142	轴用挡圈 C10	RETAINING RING EXTERNAL C10	1	
18	4173500200	SA4638001	X-左轮组件	X-LEFT PULLEY	1	
19	S10019	012060636	螺钉 M6×6	SET SCREW SOCKET (FT) M6×6	1	
20	B06007	076806606	球轴承 6806VV	BALL BEARING 6806VV	2	
21	H01004	048420242	孔用挡圈 C42	RETAINING RING EXTERNAL C42	2	
22	41701004	SA4642001	X-轮基座	X-PULLEY BRACKET	1	
23	S05124	018501636	螺栓 M5×16	BOLT SOCKET M5×16	2	
24	W01009	025050236	平垫圈 M5	WASHER PLAIN M5	2	
25	4173500300	SA4643001	X-右轮组件	X-RIGHT PULLEY ASSY	1	
26	41728001	S20356001	平垫圈 10	WASHER PLAIN 10	1	
27	B10015	SA4647001	球轴承 6900ZZNR	BALL BEARING 6900ZZNR	2	
28	41702005	SA4648001	X-轮支点轴	X-PULLEY FULCRUM SHAFT	1	
29	S10019	012060636	螺钉 M6×6	SET SCREW SOCKET (FT) M6×6	2	
30	41712013	SA4650001	Y-传感板	Y-SENSOR PLATE	1	
31	S05119	018402036	螺栓 M4×20	BOLT SOCKET M4×20	2	
32	41724007	SA4651101	Y-LM 导向	Y-LM GUIDE	2	
33	41728002	SA4652101	Y-LM 垫片	Y-LM SPACER	2	
34	S02032	061300616	螺钉 M3×6	SCREW FLAT M3×6	16	
35	S05119	018402036	螺栓 M4×20	BOLT SOCKET M4×20	8	
36	W01006	025040236	平垫圈 M4	WASHER PLAIN M4	8	
37	W02008	028040246	弹簧垫圈 2-4	WASHER SPRING 2-4	8	
38	41709032		挡块	CLAMP H-POSITION	2	T1310
39	S05119	018402036	螺栓 M4×20	BOLT SOCKET M4×20	2	T1310
40	41711062		固定板	HOLDER PLATE	2	
41	41726020	SA5220001	调节销	ADJUST PIN	4	
42	S09005	012030536	螺钉 M3×5	SCREW FLAT M3×5	4	

C2 . 送料装置 / Feed mechanism

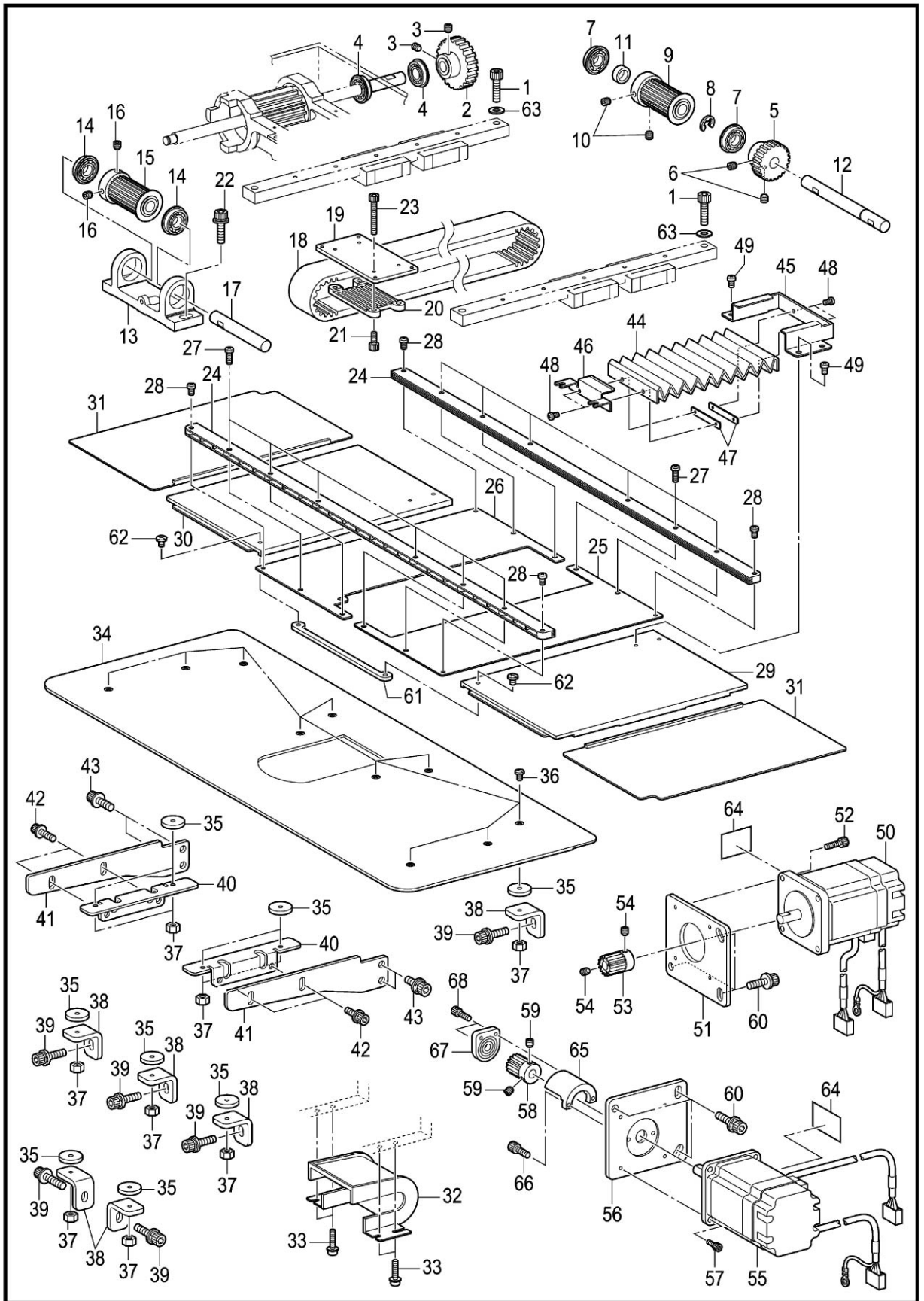

C2、送料装置/Feed mechanism

序号 No.	公司件号 Part. No.	参考件号 Ref. No.	零部件名称	NAME OF PARTS	数量 Amt.	备注
1	S05111	018062036	螺栓 M6×20	BOLT SOCKET M6×20	4	
2	41725003	SA4653001	X-送布齿轮	X-FEED GEAR	1	
3	S10019	012060636	螺钉 M6×6	SET SCREW SOCKET (FT) M6×6	2	
4	B10015	SA4647001	球轴承 6900ZZNR	BALL BEARING 6900ZZNR	2	
5	41725004	SA4654001	Y-送布齿轮	Y-FEED GEAR	1	
6	S10019	012060636	螺钉 M6×6	SET SCREW SOCKET (FT) M6×6	2	
7	B10015	SA4647001	球轴承 6900ZZNR	BALL BEARING 6900ZZNR	2	
8	H05033	048080342	挡圈 E8	RETAINING RING E8	1	
9	4173501100	SA4655101	Y-轮组件	Y-PULLEY ASSY	1	
10	S10019	012060636	螺钉 M6×6	SET SCREW SOCKET (FT) M6×6	2	
11	41703009	SA4658001	Y-轮轴套	Y-PULLEY COLLAR	1	
12	41702006	SA4659001	Y-驱动轴	Y-PULLEY DRIVING SHAFT	1	
13	41701005	SA4661001	Y-轮基座	Y-PULLEY BRACKET	1	
14	B10015	SA4647001	球轴承 6900ZZNR	BALL BEARING 6900ZZNR	2	
15	4173502100	SA4655101	基座带轮组件	Y-PULLEY ASSY	1	
16	S10019	012060636	螺钉 M6×6	SET SCREW SOCKET (FT) M6×6	2	
17	41702007	SA4662001	Y-轮支点轴	Y-PULLEY FULCRUM SHAFT	1	
18	41735005	SA4663001	Y-GT 皮带	Y-GT BELT	1	
19	41712014	SA4664001	Y-皮带支架板	BELT SUPPORT PLATE Y	1	
20	41712015	SA4665001	Y-皮带支撑板	Y-BELT WORK CLAMP PLATE	1	
21	S05116	018400836	螺栓 M4×8	BOLT SOCKET M4×8	4	
22	417S30304	SA2972001	螺栓 M6×20	BOLT SOCKET (S/P WASHER) M6×20	2	
23	S05119	018402036	螺栓 M4×	BOLT SOCKET M4×20	4	
24	41711061	SA4667101	盖轨道	COVER RAIL	2	
25	41712017	SA4671001	固定盖 (R)	FIXATION R	1	
26	41712018	SA4672001	固定盖 (L)	FIXATION L	1	
27	417S30021	062401016	螺钉 M4×10	SCREW FAN M4×10	12	
28	417S30009	062400416	螺钉 M4×6	SCREW FAN M4×6	4	
29	4171201900	SA4860101	内盖组件 R	INSIDE COVER R ASSY	1	
30	4171202000	SA4861101	内盖组件 L	INSIDE COVER L ASSY	1	
31	4171202100	SA4670101	外盖组件	OUTSIDE COVER ASSY	2	
32	41711002	SA4673001	Y-皮带轮盖	BELT COVER Y	1	
33	417S30025	0A5401006	螺栓 (带垫圈) M4×10DB	SCREW PAN (S/P WASHER) M4×10	2	
34	41712022	SA4675201	补助板	AUXILIARY PLATE	1	
35	41722010	SA4677101	补助板缓冲	AUXILIARY PLATE CUSHION	10	
36	417S15003	S23849001	螺钉 M4×12	SCREW M4×12	10	
37	N01015	021400216	六角螺母 M4	NUT 2 M4	10	
38	41712023	SA4676001	补助板支架	AUXILIARY PLATE BRACKET	6	
39	417S30037	S42446001	螺栓 M6×14	BOLT SOCKET (S/P WASHER) M6×14	6	
40	41712024	SA6434001	补助板支架 U	SUPPORT PLATE GUIDE U	2	
41	41712025	SA6435001	补助板支架 D	SUPPORT PLATE GUIDE D	2	
42	417S30035	S55484002	螺栓 (带垫圈) M5×10	BOLT SOCKET (S/P WASHER) M5×10	4	
43	417S30037	S42446001	螺栓 M6×14	BOLT SOCKET (S/P WASHER) M6×14	4	
44	41722011	SA4679101	蛇纹管	BELLOW	1	
45	41712026	SA4680101	蛇纹管支架 R	BELLOW PRESSER R	1	
46	41712027	SA4681001	蛇纹管支架 F	BELLOW PRESSER F	1	
47	41712060	SA4682001	板螺母	BELLOW NUT	2	
48	S04036	062300416	螺钉 M3×4	SCREW FAN M3×4	4	
49	S04080	062400416	螺钉 M4×4	SCREW FAN M4×4	4	
50	41730041	SA4820201	脉冲马达组件 X	PULSE MOTOR ASSY X	1	
51	41712029	SA4684001	马达安装板	MOTOR BRACKET PLATE	1	
52	S05048	018401036	螺钉 M4×10	BOLT SOCKET M4×10	4	
53	41725005	SA3707001	驱动齿轮 16	GEAR 16	1	
54	S09041	012060536	螺钉 M6×5	SET SCREW SOCKET (FT) M6×5	2	
55	41730042	SA4823101	脉冲马达组件 Y	PULSE MOTOR ASSY Y	1	
56	41712029	SA4684001	马达安装板	MOTOR BRACKET PLATE	1	
57	S05048	018401036	螺钉 M4×10	BOLT SOCKET M4×10	4	
58	41725005	SA3707001	驱动齿轮 16	GEAR 16	1	
59	S09041	012060536	螺钉 M6×5	SET SCREW SOCKET (FT) M6×5	2	
60	417S30037	S42446001	螺栓 M6×14	BOLT SOCKET (S/P WASHER) M6×14	6	
61	41712030	SA6306001	盖连接板	COVER CONNECT PLATE	1	

C2 . 送料装置 / Feed mechanism

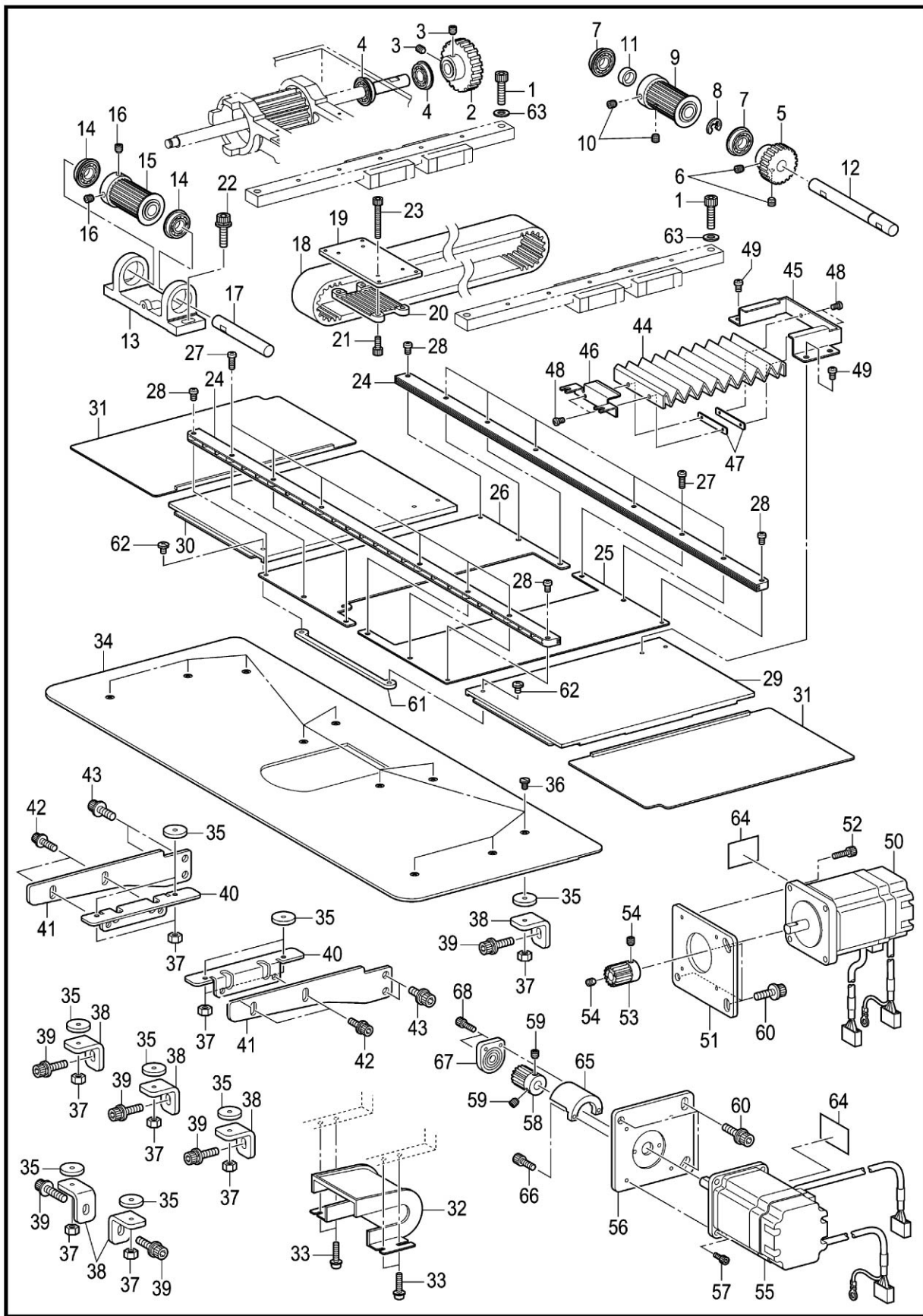

C2、送料装置/Feed mechanism

序号 No.	公司件号 Part. No.	参考件号 Ref. No.	零部件名称	NAME OF PARTS	数量 Amt.	备注
62	417S15006	S23418002	螺钉 M4×5	SCREW M4×5	2	
63	41728012	118735001	垫圈	WASHER	4	
64	41737005	SA4224001	注意符号 30×40	MARK ATTENTION 30×40	2	
65	41712100	SA6450101	轴承支架座	BEARING HOLDER BASE	1	
66	S05121	018501036	螺栓 M5×10	BOLT SOCKET M5×10	2	
67	4171210100	SA6451101	轴承支架组件	BEARING HOLDER ASSY	2	
67	41712101	SA6449001	轴承支架	BEARING HOLDER	2	
67	41724005		调心球轴承 126	BALL BEARING 126	1	
68	S05048	018401036	螺钉 M4×10	BOLT SOCKET M4×10	2	

C3、送料装置/Feed mechanism (T1310)

序号 No.	公司件号 Part. No.	参考件号 Ref. No.	零部件名称	NAME OF PARTS	数量 Amt.	备注
			<电磁式>	<For Solenoid type>		
1	41701006	SA4686101	压脚臂	WORK CLAMP	1	
2	41711007	SA4687101	滑块	SLIDER	1	
3	H03008	048100142	轴用挡圈 C10	RETAINING RING EXTERNAL C10	1	
4	41712031	SA4688001	滑块支架	SUPPORT SLIDER	1	
5	41726001	SA4689001	滑块支架轴	SUPPORT SHAFT SLIDER	1	
6	H03018	048040142	轴用挡圈 C4	RETAINING RING EXTERNAL C4	2	
7	41712032	SA4690001	压脚柄 R	WORK CLAMP LIFTER LEVER R	1	
8	41712033	SA4691001	压脚柄 L	WORK CLAMP LIFTER LEVER L	1	
9	41702012	SA4692001	压脚臂杆轴	WORK CLAMP LIFTER SHAFT	1	
10	S10019	012060636	螺钉 M6×6	SET SCREW SOCKET (FT) M6×6	1	
11	H03006	048080142	轴用挡圈 C8	RETAINING RING EXTERNAL C8	1	
12	41712133	110367001	垫圈 8	WASHER PLAIN SPECIAL 8	1	
13	41708002	SA3231001	紧圈 B	SET SCREW COLLAR B	1	
14	S09041	012060536	螺钉 M6×5	SET SCREW SOCKET (FT) M6×5	2	
15	41712034	SA4696001	连杆	CONNECTING ROD	2	
16	41702021	SA4693001	弹簧挂钩轴A	SPRING HOLDER SHAFT A	1	
17	417S30003	SA4697001	段螺钉 M5	SHOULDER SCREW M5	2	
18	41702009	SA4694001	弹簧挂钩轴B	SPRING HOLDER SHAFT B	1	
19	S10019	012060636	螺钉 M6×6	SET SCREW SOCKET (FT) M6×6	2	
20	41727002	SA4695001	弹簧	SPRING LIFT	1	
21	41712035	SA4698001	连接板	CONNECTING LINK	2	
22	417S12002	SA4700001	弹簧挂钩	WORK CLAMP SPRING HOLDER	2	
23	N01017	021500216	六角螺母 M5	NUT 2 M5	2	
24	41727003	SA4701001	弹簧	WORK CLAMP SPRING	2	
25	41712036	SA4702001	压脚臂杆 R	WORK CLAMP LIFTER LEVER R	1	
26	41712037	SA4703001	压脚臂杆 L	WORK CLAMP LIFTER LEVER L	1	
27	41702012	SA4692001	压脚臂杆轴	WORK CLAMP LIFTER LEVER L	1	
28	S10019	012060636	螺钉 M6×6	SET SCREW SOCKET (FT) M6×6	1	
29	H03006	048080142	轴用挡圈 C8	RETAINING RING EXTERNAL C8	1	
30	41712133	110367001	垫圈 8	WASHER PLAIN SPECIAL 8	1	
31	41708002	SA3231001	紧圈 B	SET SCREW COLLAR B	1	
32	S09041	012060536	螺钉 M6×5	SET SCREW SOCKET (FT) M6×5	2	
33	41712038	SA4699001	定位	STOPPER	2	
34	S05120	018500836	螺栓 M5×8	BOLT SOCKET M5×8	4	
35	W01009	025050236	平垫圈 M5	WASHER PLAIN M5	4	
36	W02001	028050246	弹簧垫圈 2-5	WASHER SPRING 2-5	4	
37	4170901300	SA4863001	压脚导向组件 A	WORK CLAMP GUIDE A ASSY	1	
38	417S15003	S23849001	螺钉 M4×16	SCREW M4×16	2	
39	4170901400	SA4864001	压脚导向组件 B	WORK CLAMP GUIDE B ASSY	2	
40	417S30034	S55482001	螺栓 (带垫圈) M4×14	BOLT SOCKET (S/P WASHER) M4×14	4	
41	4170901500	SA4712001	压脚滑块组件 R	WORK CLAMP SLIDER ASSY R	1	
42	4170901600	SA4714001	压脚滑块组件 L	WORK CLAMP SLIDER ASSY L	1	
43	41724002	SA4706101	压脚挡板组件	WORK CLAMP RETAINER ASSY	4	
44	41712039	SA4708001	压脚	WORK CLAMP	1	
45	417S30036	S55485001	螺栓 (带垫圈) M5×12	BOLT SOCKET (S/P WASHER) M5×12	2	
46	S09009	012501031	螺钉 M5×10	SET SCREW SOCKET (FT) M5×10	2	
47	N01017	021500216	六角螺母 M5	NUT 2 M5	2	
48	417S20001	SA4709001	定位段螺钉	SHOULDER SCREW	2	
49	41712040	SA4866101	压板组件 1310	WORK CLAMP 1310 ASSY	1	
50	417S30035	S55484002	螺栓 (带垫圈) M5×10	BOLT SOCKET (S/P WASHER) M5×10	2	
51	L02006	017501616	螺栓 M5×16	BOLT M5×16	4	
52	W01009	025050236	平垫圈 M5	WASHER PLAIN M5	4	
53	W02001	028050246	弹簧垫圈 2-5	WASHER SPRING 2-5	4	
54	41712041	SA4715001	送料板 1310	FEED PLATE 1310	1	
55	417S30035	S55484002	螺栓 (带垫圈) M5×10	BOLT SOCKET (S/P WASHER) M5×10	2	

C4 . 送料装置 / Feed mechanism

< 空压式 / For Pneumatic type >

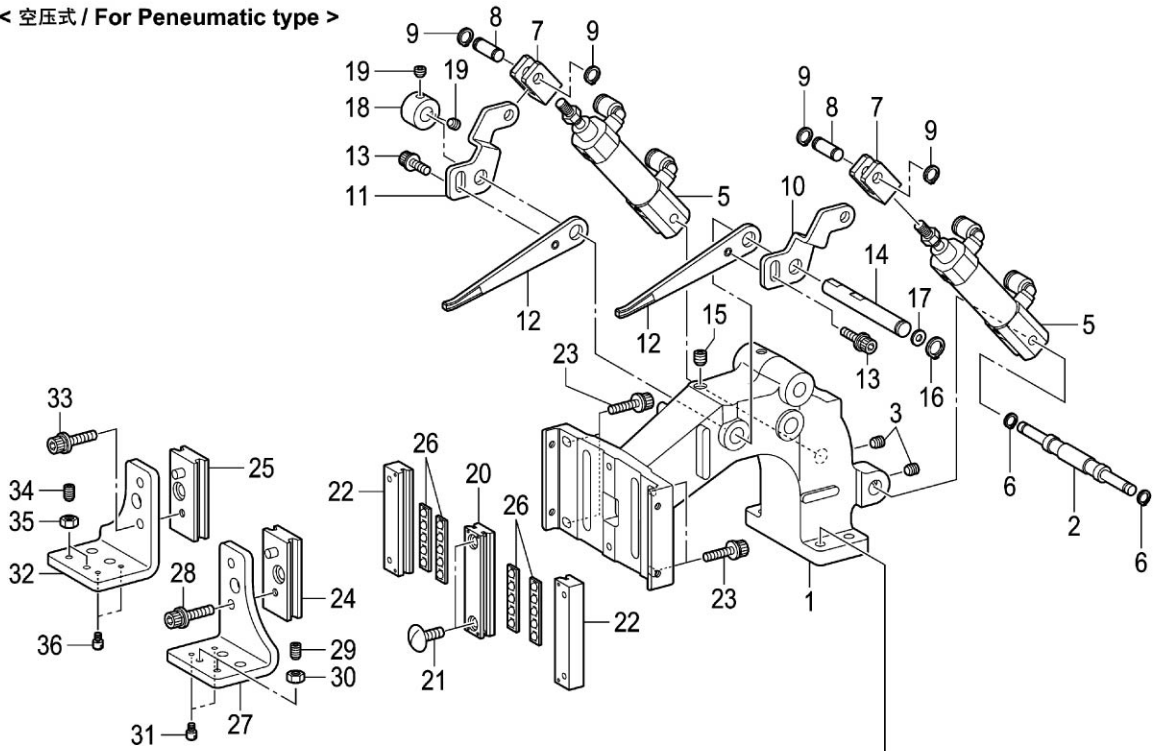

< 用于 311G / For 311G >

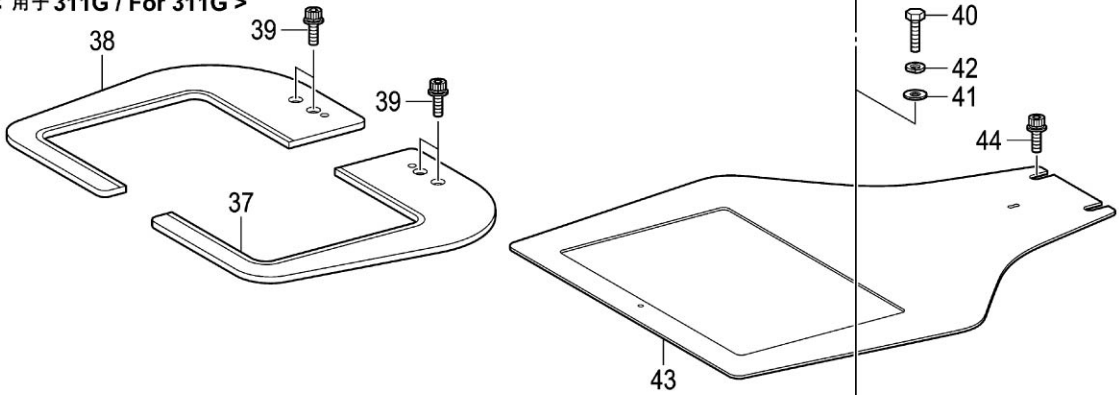

< 用于 326G / For 326G >

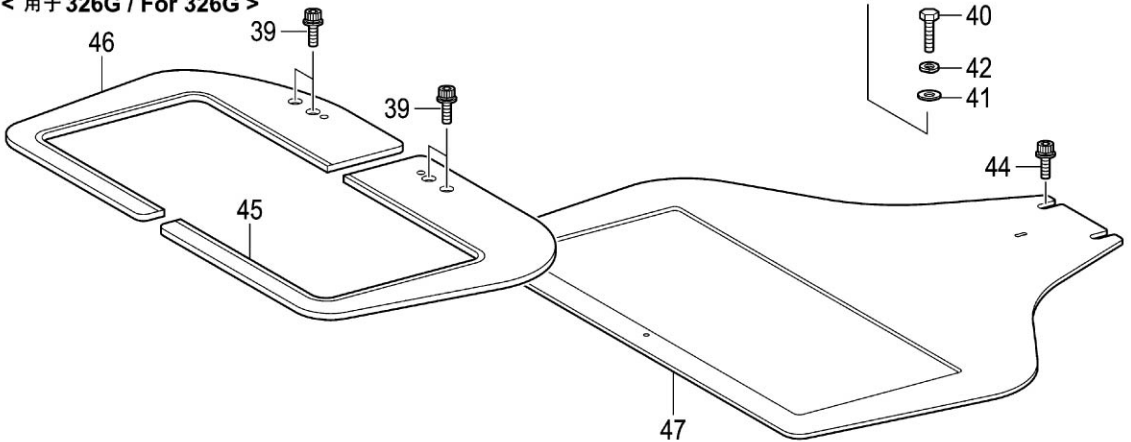

C4、送料装置/Feed mechanism

序号 No.	公司件号 Part. No.	参考件号 Ref. No.	零部件名称	NAME OF PARTS	数量 Amt.	备注
1	41701006	SA4686101	压脚臂	WORK CLAMP	1	
2	41702011	SA4717001	气缸轴	CYLINDER SHAFT	1	
3	S10019	012060636	螺钉 M6×6	SET SCREW SOCKET (FT) M6×6	2	
5	41730035	SA4719001	气缸组件 R	AIR CYLINDER ASSY	2	
6	H03019	048050142	轴用挡圈 C5	RETAINING RING EXTERNAL C5	2	
7	41709012	SA4720001	气缸接头	CYLINDER JOINT	2	
8	41726002	SA4721001	气缸接头轴	CYLINDER JOINT SHAFT	2	
9	H03003	048060142	轴用挡圈 C6	RETAINING RING EXTERNAL C6	4	
10	41712042	SA4722001	压脚柄 R(气压)	WORK CLAMP LIFTER LEVER R AIR	1	
11	41712043	SA4723001	压脚柄 L(气压)	WORK CLAMP LIFTER LEVER L AIR	1	
12	41712044	SA4724001	压脚臂杆(气压)	WORK CLAMP LIFTER SHAFT AIR	2	
13	417S30033	S55479001	螺栓(带垫圈) M4×8	BOLT SOCKET(S/P WASHER) M4×8	2	
14	41702012	SA4692001	压脚臂杆轴	WORK CLAMP LIFTER SHAFT	1	
15	S10019	012060636	螺钉 M6×6	SET SCREW SOCKET (FT) M6×6	1	
16	H03006	048080142	轴用挡圈 C8	RETAINING RING EXTERNAL C8	1	
17	41712133	110367001	垫圈 8	WASHER PLAIN SPECIAL 8	1	
18	41708002	SA3231001	紧圈 B	SET SCREW COLLAR B	1	
19	S09041	012060536	螺钉 M6×5	SET SCREW SOCKET (FT) M6×5	2	
20	4170901300	SA4863001	压脚导向组件 A	WORK CLAMP GUIDE A ASSY	1	
21	417S15003	S23849001	螺钉 M4×16	SCREW M4×16	2	
22	4170901400	SA4864001	压脚导向组件 B	WORK CLAMP GUIDE B ASSY	2	
23	417S30034	S55482001	螺栓(带垫圈) M4×14	BOLT SOCKET(S/P WASHER) M4×14	4	
24	4170901500	SA4712001	压脚滑块组件 R	WORK CLAMP SLIDER ASSY R	1	
25	4170901600	SA4714001	压脚滑块组件 L	WORK CLAMP SLIDER ASSY L	1	
26	41724002	SA4706101	压脚挡板组件	WORK CLAMP RETAINER ASSY	4	
27	41712045	SA4725001	压脚 R	WORK CLAMP R	1	
28	417S30036	S55485001	螺栓(带垫圈) M5×12	BOLT SOCKET(S/P WASHER) M5×12	1	
29	S09009	012501031	螺钉 M5×10	SET SCREW SOCKET (FT) M5×10	2	
30	N01017	021500216	六角螺母 M5	NUT 2 M5	2	
31	417S20001	SA4709001	定位段螺钉	SHOULDER SCREW	2	
32	41712046	SA4726001	压脚 L	WORK CLAMP L	1	
33	417S30036	S55485001	螺栓(带垫圈) M5×12	BOLT SOCKET(S/P WASHER) M5×12	1	
34	S09009	012501031	螺钉 M5×10	SET SCREW SOCKET (FT) M5×10	2	
35	N01017	021500216	六角螺母 M5	NUT 2 M5	2	
36	417S20001	SA4709001	定位段螺钉	SHOULDER SCREW	2	
			<用于1310>	<For 1310>		
37	41712047	SA4868101	压板组件 1310R	WORK CLAMP 311R ASSY	1	
38	41712048	SA4869101	压板组件 1310L	WORK CLAMP 311L ASSY	1	
39	417S30035	S55484002	螺栓(带垫圈) M5×10	BOLT SOCKET(S/P WASHER) M5×10	4	
40	L02006	017501616	螺栓 M5×16	BOLT M5×16	4	
41	W01009	025050236	平垫圈 M5	WASHER PLAIN M5	4	
42	W02001	028050246	弹簧垫圈 2-5	WASHER SPRING 2-5	4	
43	41712049	SA4715001	送料板 1310	FEED PLATE 311G	1	
44	417S30035	S55484002	螺栓(带垫圈) M5×10	BOLT SOCKET(S/P WASHER) M5×10	2	
			<用于2210>	<For 2210>		
45	41712050	SA4870101	压板组件 2210R	WORK CLAMP 2210R ASSY	1	
46	41712051	SA4871101	压板组件 2210L	WORK CLAMP 2210L ASSY	1	
39	417S30035	S55484002	螺栓(带垫圈) M5×10	BOLT SOCKET(S/P WASHER) M5×10	4	
40	L02006	017501616	螺栓 M5×16	BOLT M5×16	4	
41	W01009	025050236	平垫圈 M5	WASHER PLAIN M5	4	
42	W02001	028050246	弹簧垫圈 2-5	WASHER SPRING 2-5	4	
44	417S30035	S55484002	螺栓(带垫圈) M5×10	BOLT SOCKET(S/P WASHER) M5×10	2	
47	41712052	SA4852001	送料板 2210	FEED PLATE 2210	1	

D1 . 拾压装置 / Work clamp lifter mechanism

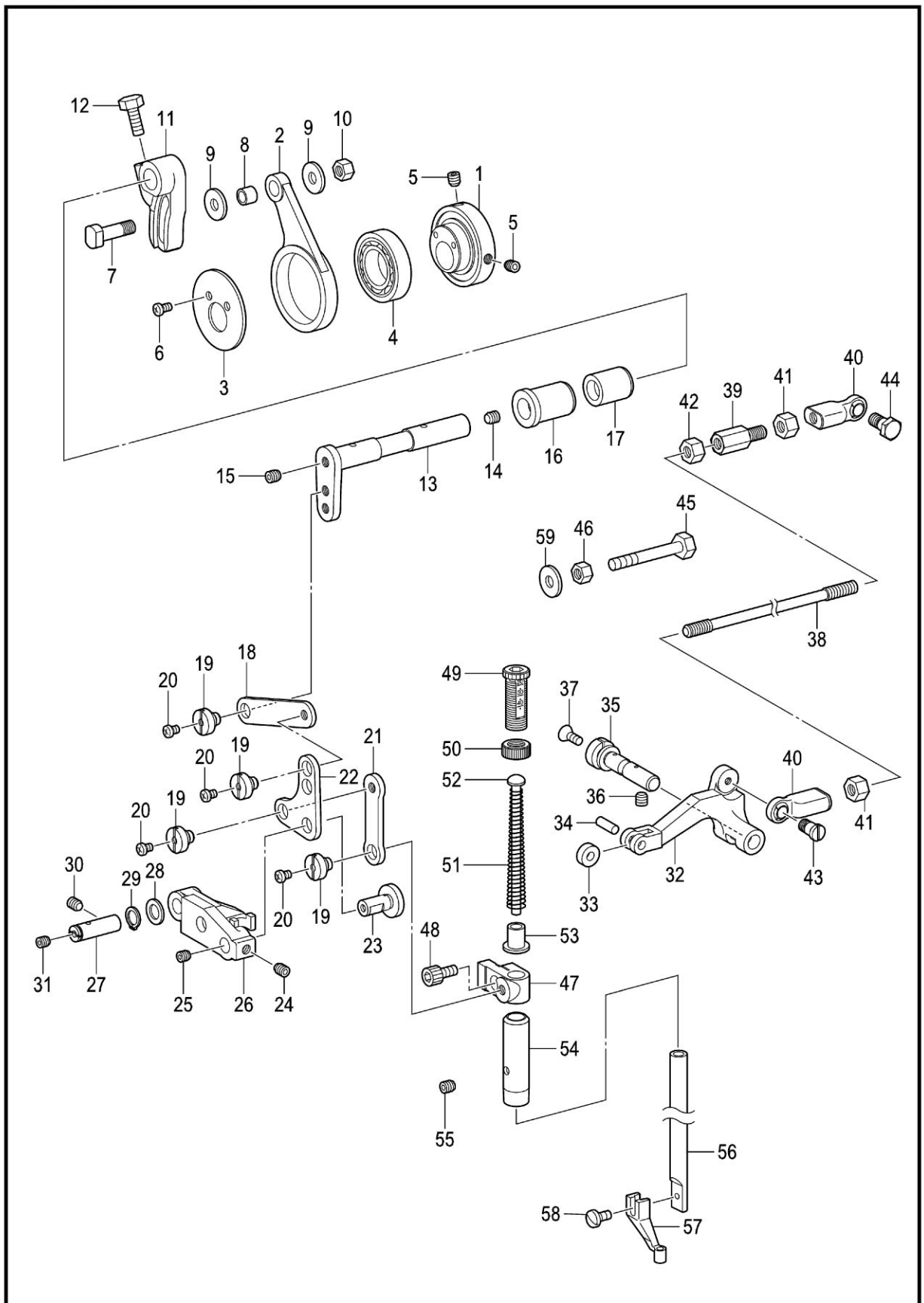

D1、抬压脚装置/Work clamp lifter mechanism

序号 No.	公司件号 Part. No.	参考件号 Ref. No.	零部件名称	NAME OF PARTS	数量 Amt.	备注
1	41710001	SA4759001	凸轮	STEPPING CLAMP CAM	1	
2	41705001	SA4760001	连杆	STEPPINGCLAMP CON. ROD	1	
3	41728003	SA4763001	垫圈	WASHER STEPPING CLAMP CAM	1	
4	B06008	623033000	轴承 6805VV	BALL BEARING 6805VV	1	
5	S10018	S23651001	固定螺钉 M6×0.75-6	SET SCREW SOCKET (FT)M6×6	2	
6	S04035	062400616	螺钉 M4×6	SCREW PAN M4×6	2	
7	41726003	SA4761001	滚轮轴	ROLLER SHAFT STEPPING CLAMP	1	
8	41703010	SA4762001	滚轮	ROLLER STEPPING CLAMP	1	
9	41728004	SA4302001	垫圈	WASHER	2	
10	N01021	021060106	螺母 M6	NUT 1 M6	1	
11	41709017	SA4764001	压臂 R	STEPPING CLAMP ARM R	1	
12	L02032	017061216	螺栓 M6×12	BOLT M6×12	1	
13	41702013	SA4765001	压臂 F	STEPPING CLAMP ARM F	1	
14	S10019	012060636	螺钉 M6×6	SET SCREW SOCKET (FT)M6×6	1	
15	S10018	S23651001	固定螺钉 M6×0.75-6	SET SCREW SOCKET (FT)M6×6	1	
16	41703011	SA4766001	压臂轴套 F	BUSH STEPPING CLAMP F	1	
17	41703012	SA4767001	压臂轴套 R	BUSH STEPPING CLAMP R	1	
18	41712053	SA4768001	间歇连杆 A	STEPPING CLAMP LINK A	1	
19	417S30007	SA4769001	段螺钉 6	SHOULDER SCREW 6	4	
20	S04036	062300416	螺钉 M3×4	SCREW PAN M3×4	4	
21	41712054	SA4770001	间歇连杆 B	STEPPING CLAMP LINK B	1	
22	41712055	SA4772001	间歇联杆	STEPPING CLAMP LINK	1	
23	41726004	SA4773001	联杆轴	SHAFT STEPPING CLAMP LINK	1	
24	S10019	012060636	螺钉 M6×6	SET SCREW SOCKET (FT)M6×6	1	
25	S09006	012400436	螺钉 M4×4	SET SCREW SOCKET (FT)M4×4	1	
26	41709018	SA4777001	联接板	STEPPING CLAMP LIFTER LINK	1	
27	41702014	SA4771001	联接板轴	SHAFT STEPPING CLAMP LIFTER LINK	1	
28	41728031	SA2161001	垫圈	WASHER	1	
29	H03006	048080142	轴用挡圈 C8	RETAINING RING EXTERNAL C8	1	
30	S10019	012060636	螺钉 M6×6	SET SCREW SOCKET (FT)M6×6	1	
31	S09006	012400436	螺钉 M4×4	SET SCREW SOCKET (FT)M4×4	1	
32	41709019	SA4779001	间歇提升杆	STEPPING CLAMP LIFTER	1	
33	41703013	SA4781001	提升杆滑轮	ROLLER STEPPING CLAMP LIFTER	1	
34	41726005	141362001	滚轮轴	ROLLER	1	
35	41702015	SA4780001	提升杆轴	SHAFT STEPPING CLAMP LIFTER	1	
36	S10019	012060636	螺钉 M6×6	SET SCREW SOCKET (FT)M6×6	1	
37	S02039	S25310101	螺钉 M4	SCREW FLAT M4	1	
38	41702016	SA4775001	提升连杆	STEPPING CLAMP LIFTER ROD	1	
39	417S12003	SA4853001	提升连杆接头	JOINT STEPPING CLAMP LIFTER	1	
40	4170500200	SA2663001	接头组件 R	BALL JOINT ASSY	2	
41	N01012	021060306	六角螺母 M6	NUT 3 M6	2	
42	417S16001	SA3227001	螺母 M6×0.75	NUT (FT)M6	1	
43	417S30008	SA4776001	段螺钉	SHOULDER SCREW	1	
44	417S12005	S32462001	段螺钉B M6	SHOULDER SCREW B M6	1	
45	L01007	017065002	螺栓 M6×50	BOLT M6×50	1	
46	N01021	021060106	螺母 M6	NUT 1 M6	1	
47	41709020	SA4778001	压紧杆接头	PRESSER BAR CLAMP	1	
48	S05116	018400836	螺栓 M4×8	BOLT SOCKET M4×8	1	
49	129S30003	SA1174001	调节螺栓 M14	PESSER ADJUSTING SCREW M14	1	
50	129S16001	SA1175001	调节螺母 M14	ADJUST SCREW NUT	1	
51	41727004	SA5300001	弹簧	PRESSER BAR SPRING	1	
52	41702017	S10112001	弹簧导向	PRESSER BAR SPRING GUIDE	1	
53	41703014	SA5301001	弹簧管套	COLLAR PRESSER BAR SPRING	1	
54	41703015	SA2195001	压紧杆轴套	PRESSER BAR BUSH	1	
55	S09041	012060536	螺钉 M6×5	SET SCREW SOCKET (FT)M6×5	1	
56	41702018	111466101	压紧杆	PRESSER BAR	1	
57	41716001	*P. 67	压脚	WORK CLAMP	1	
58	417S15011	S13399001	螺钉 SM3. 57×12	SCREW SM3. 57×12	1	
59	41728032	151439102	垫圈	WASHER	1	

D2 . 抬压装置 / Work clamp lifter mechanism

< 电磁式 / For Solenoid type >

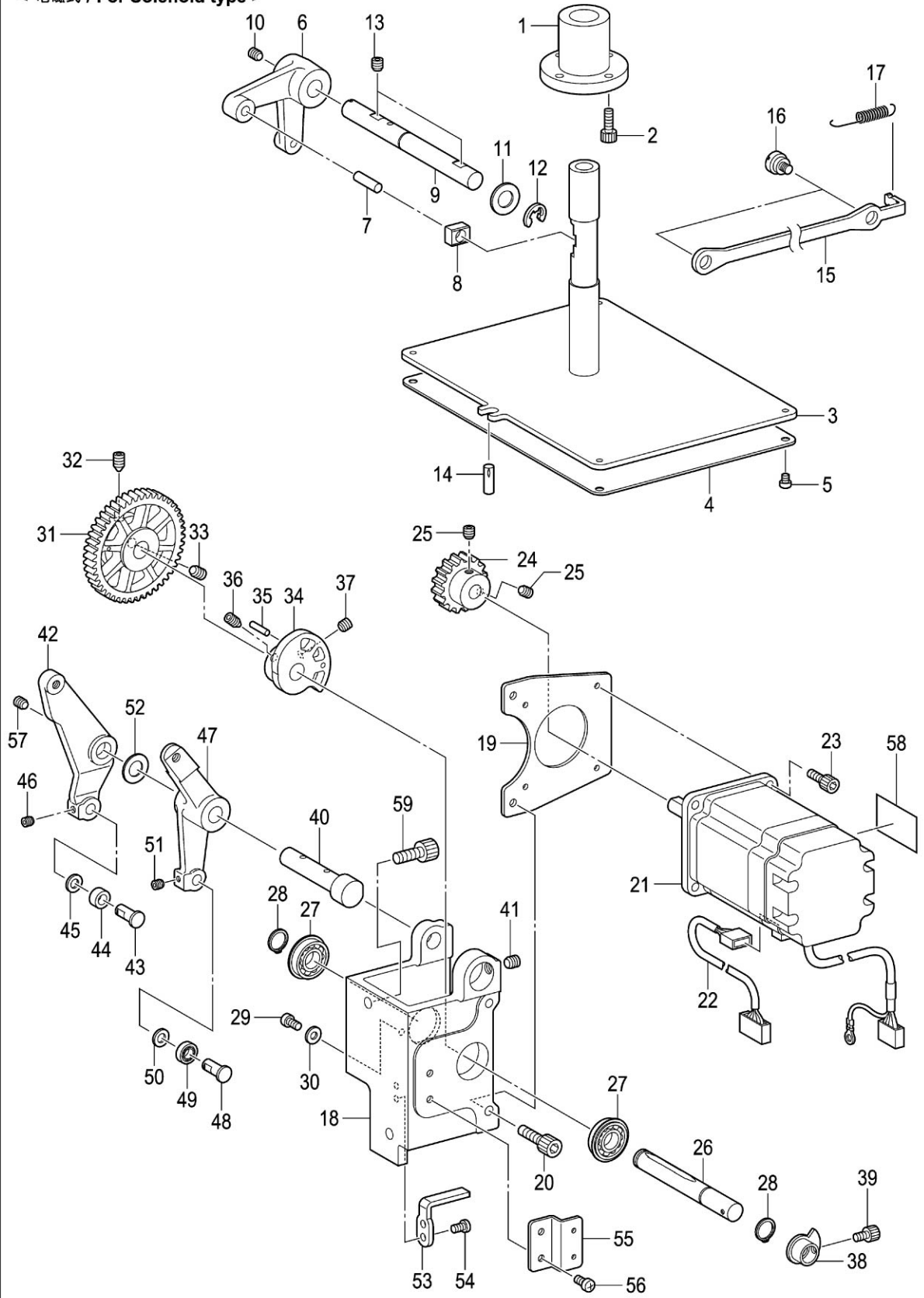

D2、抬压脚装置/Work clamp lifter mechanism (T1310)

序号 No.	公司件号 Part. No.	参考件号 Ref. No.	零部件名称	NAME OF PARTS	数量 Amt.	备注
			<电磁式>	<For Solenoid type>		
1	41724004	SA4729001	滑杆轴套	SLIDE BUSH	1	
2	S05048	018401036	螺钉 M4×10	BOLT SOCKET M4×10	4	
3	41712056	SA4731001	压脚提升板组件	WORK CLAMP LIFTER PATE ASSY	1	
4	41712057	SA4734001	底座板 E	SEAT E	1	
5	S04080	062400416	螺钉 M4×4	SCREW PAN M4×4	1	
6	41709021	SA4736001	压脚提升杆	WORK CLAMP LIFTER LEVER	1	
7	41726006	152744001	销	PIN	1	
8	41709022	102630001	压脚提升滑块	NEEDLE BAR GUIDE SLIDE BLOCK	1	
9	41702019	SA4737001	提升杆轴 B	WORK CLAMP LEVER SHAFT B	1	
10	S10019	012060636	螺钉 M6×6	SET SCREW SOCKET (FT) M6×6	1	
11	41728001	S20356001	平垫圈 10	WASHER PLAIN 10	1	
12	H05033	048080342	挡圈 E8	RETAINING RING E8	1	
13	S10019	012060636	螺钉 M6×6	SET SCREW SOCKET (FT) M6×6	2	
14	41729002	118208001	带槽销	DOWEL PIN	1	
15	41712058	SA4738001	压脚提升杆	WORK CLAMP LIFTER PATE ASSY	1	
16	417S20010	SA3438001	段螺钉	SHOULDER SCREW	2	
17	41727005	SA4739001	弹簧	PRESSER BAR SPRING	1	
18	41701008	SA4741101	马达座	MOTOR BRACKET	1	
19	41712063	SA4742001	压脚马达板	WORK CLAMP MOTOR PLATE	1	
20	S05121	018501036	螺栓 M5×10	BOLT SOCKET M5×10	2	
21	41730043	SA4826201	脉冲马达组件 P	PULSE MOTOR ASSY P	1	
22	41730044	SA4828001	马达端线 P	MOTOR HARNESS P	1	
23	S05048	018401036	螺钉 M4×10	BOLT SOCKET M4×10	4	
24	41725009	SA4743001	驱动齿轮	WORK CLAMP DRIVING GEAR	1	
25	S10019	012060636	螺钉 M6×6	SET SCREW SOCKET (FT) M6×6	2	
26	41702020	SA4744001	压脚支点轴	WORK CLAMP FULCRUM SHAFT	1	
27	B10015	SA4647001	球轴承 6900ZZNR	BALL BEARING 6900ZZNR	2	
28	H03008	048100142	轴用挡圈 C10	RETAINING RING EXTERNAL C10	2	
29	S04035	062400616	螺钉 M4×6	SCREW PAN M4×6	1	
30	W01001	025040236	平垫圈 M4	WASHER PLAIN M4	1	
31	41725010	SA4745001	凸轮齿轮	WORK CLAMP CAM GEAR	1	
32	S10021	016061031	螺钉 M6×10	SET SCREW SOCKET (CN) M6×10	1	
33	S10019	012060636	螺钉 M6×6	SET SCREW SOCKET (FT) M6×6	1	
34	41710002	SA4746001	压脚凸轮	WORK CLAMP CAM	1	
35	41724017	S35079000	滚针 3×11.8	NEEDLE ROLLER 3×11.8	1	
36	S10021	016061031	螺钉 M6×10	SET SCREW SOCKET (CN) M6×10	1	
37	S10019	012060636	螺钉 M6×6	SET SCREW SOCKET (FT) M6×6	1	
38	4170301700	SA4747001	压脚原点挡块	WORK CLAMP H-POSITION DOG	1	
39	S05115	018400636	螺栓 M4×6	BOLT SOCKET M4×6	1	
40	41702025	SA4748001	压脚柄轴	WORK CLAMP LEVER SHAFT	1	
41	S10019	012060636	螺钉 M6×6	SET SCREW SOCKET (FT) M6×6	1	
42	41709023	SA6210001	间歇驱动杆	STEPPING W-CLAMP DRIVING LEVER	1	
43	41702022	SA3441001	抬压滚轮轴	W-CLAMP LIFTER ROLLER SHAFT	1	
44	B04026	070696800	轴承 R-696ZZ	BALL BEARING RADIAL 696ZZ	1	
45	41728005	109763001	垫圈	WASHER	1	
46	S09019	012500536	螺钉 M5×5	SET SCREW SOCKET (FT) M5×5	1	
47	41709024	SA4750001	压脚驱动杆	WORK CLAMP DRIVING SHAFT	1	
48	41702022	SA3441001	抬压滚轮轴	W-CLAMP LIFTER ROLLER SHAFT	1	
49	B04026	070696800	轴承 R-696ZZ	BALL BEARING RADIAL 696ZZ	1	
50	41728005	109763001	垫圈	WASHER	1	
51	S09019	012500536	螺钉 M5×5	SET SCREW SOCKET (FT) M5×5	1	
52	41728001	S20356001	平垫圈 10	WASHER PLAIN 10	1	
53	41712061	SA4752001	凸轮定位	WORK CLAMP CAM STOPPER	1	
54	S04035	062400616	螺钉 M4×6	SCREW PAN M4×6	2	
55	41712062	SA4753001	压脚传感器板	WORK CLAMP SENSOR PLATE	1	
56	S04035	062400616	螺钉 M4×6	SCREW PAN M4×6	2	
57	S10019	012060636	螺钉 M6×6	SET SCREW SOCKET (FT) M6×6	1	
58	41737005	SA4224001	注意符号 30×40	MARK ATTENTION 30×40	1	
59	S05110	018061236	螺栓 M6×12	BOLT SOCKET M6×12	2	

D3 . 拾压装置 / Work clamp lifter mechanism

< 空压式 / For Pneumatic type >

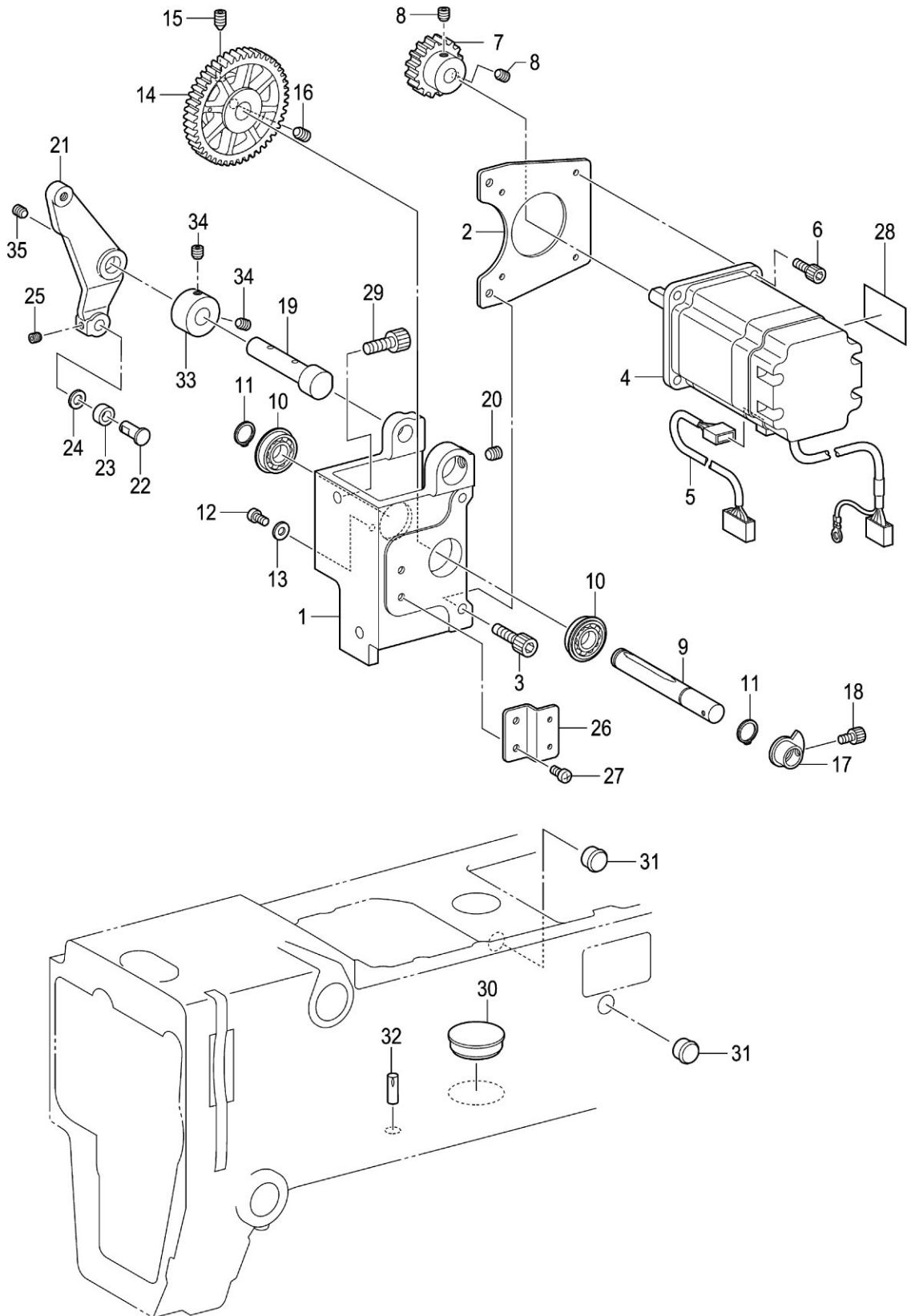

D3、抬压脚装置/Work clamp lifter mechanism

序号 No.	公司件号 Part. No.	参考件号Ref. No.	零部件名称	NAME OF PARTS	数量 Amt.	备注
			<空压式>	<For Penumatic type>		
1	41701008	SA4741101	马达座	MOTOR BRACKET	1	
2	41712063	SA4742001	压脚马达板	WORK CLAMP MOTOR PLATE	1	
3	S05121	018501036	螺栓 M5×10	BOLT SOCKET M5×10	2	
4	41730043	SA4826201	脉冲马达组件 P	PULSE MOTOR ASSY P	1	
5	41730044	SA4828001	马达端线 P	MOTOR HARNESS P	1	
6	S05048	018401036	螺栓 M4×10	BOLT SOCKET M4×10	4	
7	41725009	SA4743001	驱动齿轮	WORK CLAMP DRIVING GEAR	1	
8	S10019	012060636	螺钉 M6×6	SET SCREW SOCKET (FT)M6×6	2	
9	41702020	SA4744001	压脚支点轴	WORK CLAMP FULCRUM SHAFT	1	
10	B10015	SA4647001	球轴承 6900ZZNR	BALL BEARING 6900ZZNR	2	
11	H03008	048100142	轴用挡圈 C10	RETAINING RING EXTERNAL C10	2	
12	S04035	062400616	螺钉 M4×6	SCREW PAN M4×6	1	
13	W01001	025040236	平垫圈 M4	WASHER PLAIN M4	1	
14	41725010	SA4745001	凸轮齿轮	WORK CLAMP CAM GEAR	1	
15	S10021	016061031	螺钉 M6×10	SET SCREW SOCKET (CN)M6×10	1	
16	S10019	012060636	螺钉 M6×6	SET SCREW SOCKET (FT)M6×6	1	
17	4170301700	SA4747001	压脚原点挡块	WORK CLAMP H-POSITION DOG	1	
18	S05115	018400636	螺栓 M4×6	BOLT SOCKET M4×6	1	
19	41702025	SA4748001	压脚柄轴	WORK CLAMP LEVER SHAFT	1	
20	S10019	012060636	螺钉 M6×6	SET SCREW SOCKET (FT)M6×6	1	
21	41709023	SA6210001	间歇驱动杆	STEPPING W-CLAMP DRIVING LEVER	1	
22	41702022	SA3441001	抬压滚轮轴	W-CLAMP LIFTER ROLLER SHAFT	1	
23	B10015	070696800	轴承 R-696ZZ	BALL BEARING RADIAL 696ZZ	1	
24	41728005	109763003	垫圈	WASHER	1	
25	S09019	012500536	螺钉 M5×5	SET SCREW SOCKET (FT)M5×5	1	
26	41712062	SA4753001	压脚传感器板	WORK CLAMP SENSOR PLATE	1	
27	S04035	062400616	螺钉 M4×6	SCREW PAN M4×6	2	
28	41737005	SA4224001	注意符号 30×40	MARK ATTENTION 30×40	1	
29	S05110	018061236	螺栓 M6×12	BOLT SOCKET M6×12	2	
30	41722012	159163000	橡皮塞 29	RUBBER CAP 29	1	
31	41722003	104821001	橡皮塞 10.5	RUBBER CAP 10.5	2	
32	P01011	118550001	带槽销	PIN DOWEL	1	
33	41708004	SA4757001	紧圈	SET SCREW COLLAR	1	
34	S10019	012060636	螺钉 M6×6	SET SCREW SOCKET (FT)M6×6	2	
35	S10019	012060636	螺钉 M6×6	SET SCREW SOCKET (FT)M6×6	1	

E . 下轴装置 / Lower shaft mechanism

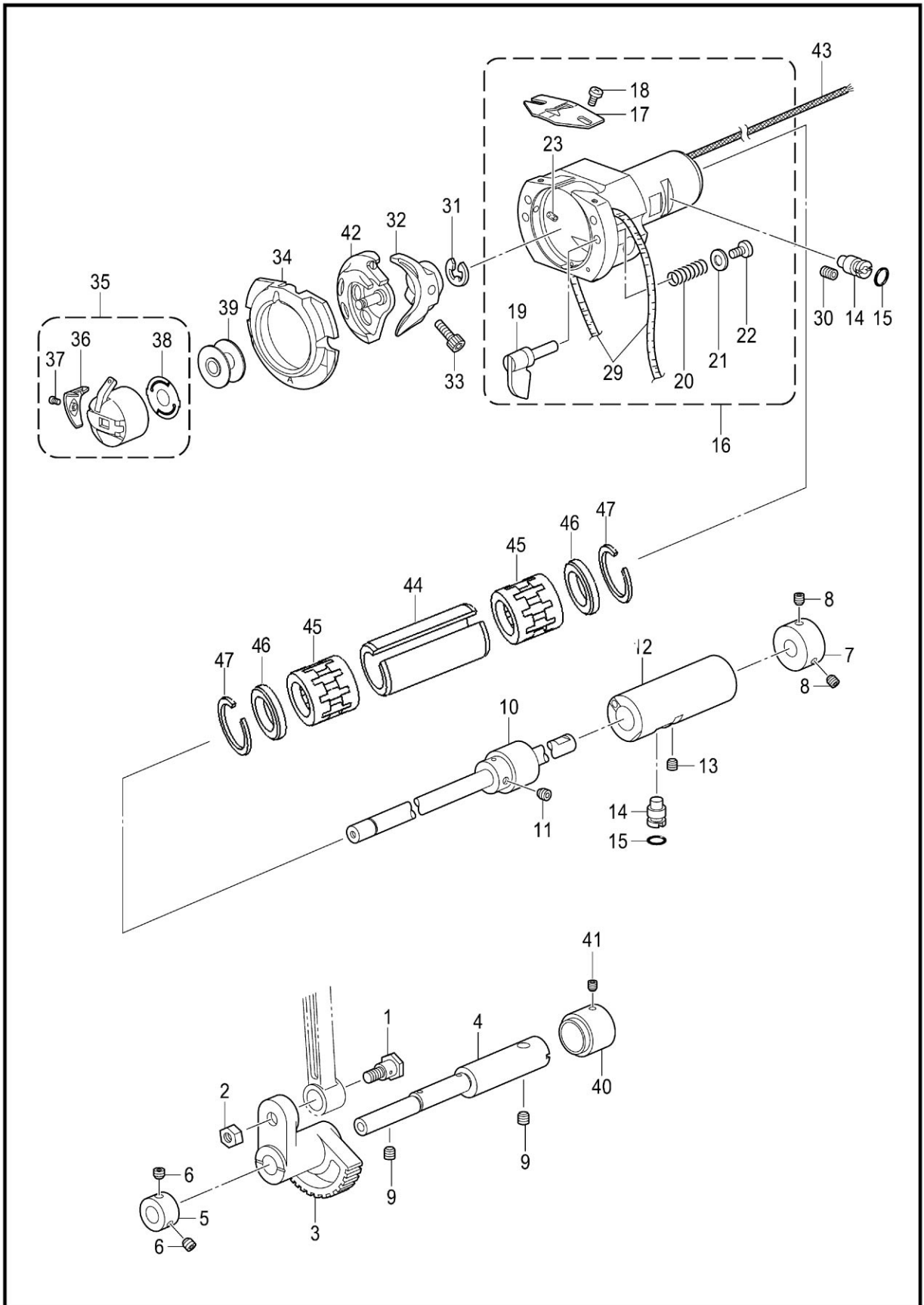

E、下轴装置/Lower shaft mechanism

序号 No.	公司件号 Part. No.	参考件号 Ref. No.	零部件名称	NAME OF PARTS	数量 Amt.	备注
1	417S30011	SA3226001	段螺钉	SHOULDER SCREW	1	
2	417S16001	SA3227001	螺母 M6×0.75	NUT (FT)M6	1	
3	41725011	SA3228101	摆动齿轮	ROCK GEAR	1	
4	41702027	SA4782001	摆动齿轮轴	ROCK GEAR SHAFT	1	
5	41708002	SA3231001	紧圈 B	SET SCREW COLLAR B	1	
6	S09011	012060536	螺钉 M6×5	SET SCREW SOCKET (FT)M6×5	2	
7	41708006	SA3233001	紧圈	SET SCREW COLLAR	1	
8	S10018	S23651001	固定螺钉 M6×0.75-6	SET SCREW SOCKET (FT)M6×6	2	
9	S10019	012060636	螺钉 M6×6	SET SCREW SOCKET (FT)M6×6	2	
10	4170202800	SA4783001	下轴组件	LOWER SHAFT ASSY	1	
11	S09019	012500536	螺钉 M5×5	SET SCREW SOCKET (FT)M5×5	1	
12	41703019	SA6216001	下轴轴套	LOWER SHAFT BUSH	1	
13	S10019	012060636	螺钉 M6×6	SET SCREW SOCKET (FT)M6×6	1	
14	41702029	SA3238101	旋梭调节轴	ADJUSTING STCD	2	
15	41722015	081003670	O形圈 PW3	O RING PW3	2	
16	41701009	SA6220001	大旋梭基座组件 G	SHUTTLE RACE BASE ASSY G	1	
17	41712190	S02429201	旋梭线导向	SHUTTLE RACE THREAD GUIDE	1	
18	417S15007	SA4199001	螺钉 M3×4	SCREW M3×4	2	
19	4172601500	SA3241001	大旋梭固定柄	S-RACE BASE SETTING CLAW	2	
20	41727006	152684101	弹簧	COMPRESSION SPRING	2	
21	W01002	026030236	垫圈 M3	WASHER PLAIN M3	2	
22	S04082	062300616	螺钉 M3×6	SCREW PAN M3×6	2	
23	41723013	153050000	油毡	S-RACE BASE FELT	2	
29	41723025	S59886001	油毡 L-360	FELT L-360	2	
30	S10019	012060636	螺钉 M6×6	SET SCREW SOCKET (FT)M6×6	1	
31	H05032	048070342	挡圈 E7	RETAINING RING E7	1	
32	41718001	SA3284101	梭托 D	DRIVER D	1	
33	S05122	018501232	螺栓 M5×12	BOLT SOCKET M5×12	1	
34	41718002	*P. 66	外旋梭	SHUTTLE RACE BASE	1	
35	4171801700	*P. 66	梭芯套组件	BOBBIN CASE ASSY	1	
36	41727015	*P. 66	调节弹簧	TENSION SPRING	1	
37	417S30005	*P. 66	螺钉	SCREW	1	
38	41727016	*P. 66	防空转弹簧	ANTI-SPIN SPRING	1	
39	41718004	*P. 66	梭芯	BOBBIN	1	
40	41703020	SA3283101	紧圈 R	SET SCREW COLLAR R	1	
41	S09019	012500536	螺钉 M5×5	SET SCREW SOCKET (FT)M5×5	1	
42	4171801800	*P. 66	中旋梭	SHUTTLE HOOK	1	
43	12923018	S32557001	油线 4×4 L=400	WICK 4×4 L=400	1	
44	41711027	SA3278001	轴圈	BUSH	1	
45	41711028	SA3276001	垫片	SPACER COLLER	2	
46	41724008		滚针轴承 K8×12×11	NEEDLE BEARING	2	
47	41729005		切口卡簧	RETAINING RING	2	

F. 供油润滑装置 / Lubrication

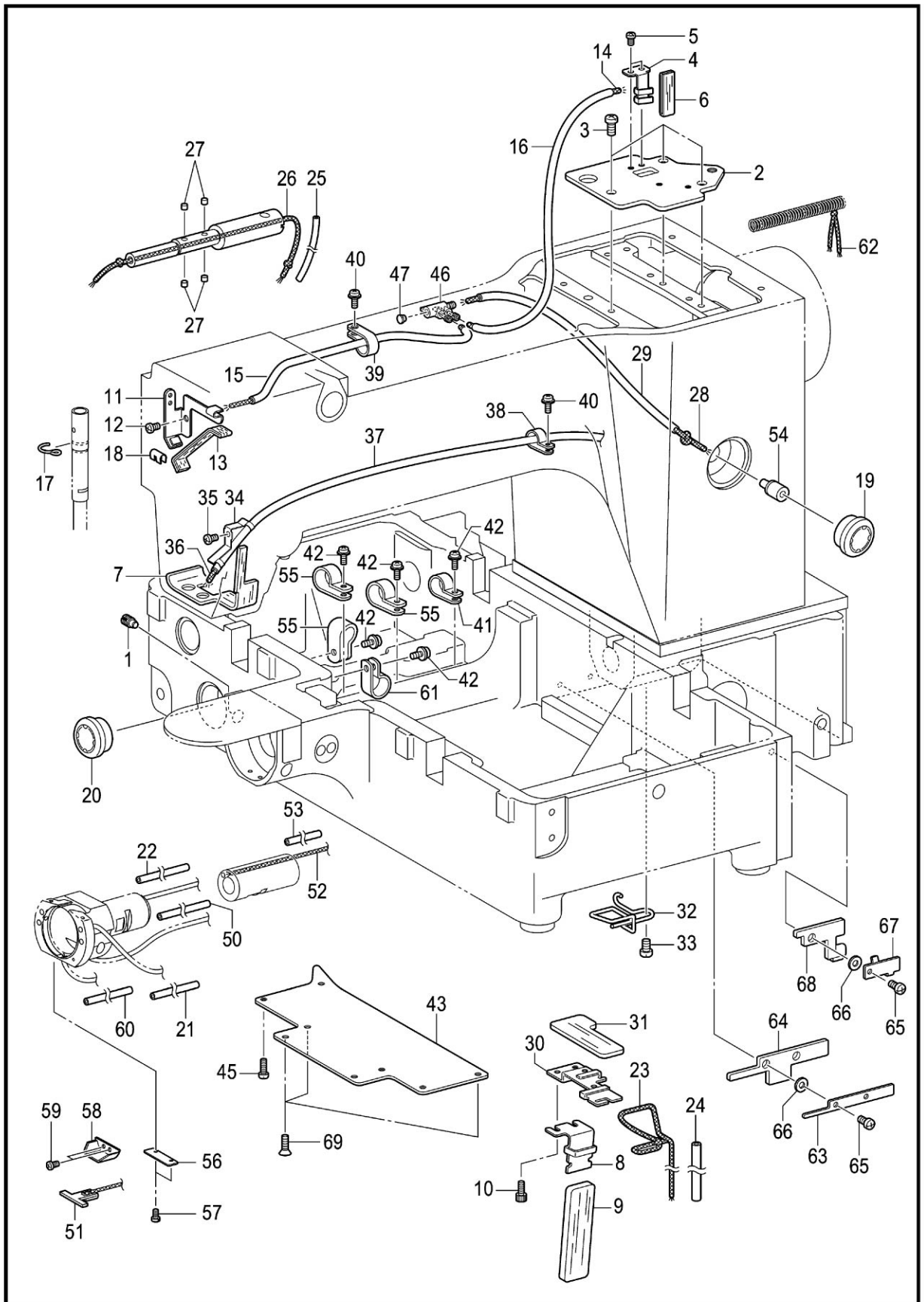

F、供油润滑装置/Lubrication

序号 No.	公司件号 Part. No.	参考件号 Ref. No.	零部件名称	NAME OF PARTS	数量 Amt.	备注
1	417S30022	SA3244001	螺钉	SET SCREW	1	
2	41712065	SA4785001	曲柄盖	CRANK COVER	1	
3	S04038	062061016	螺钉 M6×10	SCREW PAN M6×10	3	
4	41712066	SA4787001	曲柄供油板	CRANK WICK PLATE	1	
5	S04035	062400616	螺钉 M4×6	SCREW PAN M4×6	2	
6	41723008	SA5294001	毡油线 L=90	FLAT WICK L=90	1	
7	41723005	SA4786101	油毡	FELT	1	
8	41712067	SA3503201	下轴给油支架	LOWER SHAFT WICK SUPPORT	1	
9	41723006	SA3504201	下轴齿轮油毡	LOWER SHAFT GEAR FELT	1	
10	S05115	018400636	螺栓 M4×6	BOLT SOCKET M4×6	2	
11	41712068	SA4788001	供油支架	WICK SUPPORT	1	
12	S04035	062400616	螺钉 M4×6	SCREW PAN M4×6	1	
13	41723008	SA6593001	毡油线 L=180	FLAT WICK L=180	1	
14	41723026	SA5292001	油线 φ2.5 L=780	WICK L=780	1	
15	12921002	S07459100	油管 φ3×φ5 L=240	OIL TUBE L=240	1	
16	12921002	SA6576001	油管 φ3×φ5 L=210	OIL TUBE L=210	1	
17	41712069	SA6087001	油线挂钩	WICK SUPPORT	1	
18	41712070	104567101	油线支架	WICK SUPPORT	1	
19	4171100300	S49992000	油视窗	OIL GAUGE WINDOW	1	
20	4171100400	152948001	油视窗	OIL GAUGE WINDOW	1	
21	12921002	S50529000	油管 φ3×φ5 L=330	OIL TUBE L=320	1	
22	12921002	S07459100	油管 φ3×φ5 L=240	OIL TUBE L=240	1	
23	12923018	SA5292101	油线 4×4 L=680	WICK L=680	1	
24	12921002	S53175000	油管 φ3×φ5 L=450	OIL TUBE L=450	1	
25	12921002	SA5072001	油管 φ3×φ5 L=120	OIL TUBE L=120	1	
26	12923019	S45849000	油线 6×6 L=300	WICK 6×6 L=300	1	
27	41723011	S09043000	油毡	FELT	4	
28	12923018	S49982000	油线 4×4 L=400	WICK 4×4 L=400	1	
29	12921002	S48189000	油管 φ3×φ5 L=280	OIL TUBE L=280	1	
30	41712071	SA3246001	齿轮供油支架	GEAR WICK SUPPORT	1	
31	41723031	SA3280001	油毡	GEAR FELT	1	
32	41712072	SA4789101	油线夹 B	LOWER SHAFT WICK SUPPORT B	1	
33	S04033	062060816	螺钉 M6×8	SCREW PAN M6×8	1	
34	41712073	145547001	回油管管托	TUBE HOLDER	1	
35	S04035	062400616	螺钉 M4×6	SCREW PAN M4×6	1	
36	12923018	S49957000	油线 4×4 L=700	WICK 4×4 L=1370	1	
37	12921005	SA4791101	油管 φ4×φ6 L=620	OIL TUBE L=620	1	
39	41711014	149547000	压线板	CORD HOLDER 4N	1	
39	41711015	525567000	电线夹 #8	CORD HOLDER #8	1	
40	417S30025	0A5401006	螺栓(带垫圈) M4×10DB	SCREW PAN(S/P WASHER) M4×10	2	
41	41711016	525664000	电线夹 #6	CORD HOLDER #6	1	
42	417S30025	0A5401006	螺栓(带垫圈) M4×10DB	SCREW PAN(S/P WASHER) M4×10	5	
43	41712074	SA5259001	油盖	OIL COVER	1	
45	417S30021	062401016	螺钉 M4×10	SCREW PAN M4×10	5	
46	41736001	S38265000	管接头 L	TERMINAL L	1	
47	41722016	142274101	橡皮塞 4.2	RUBBER CAP 4.2	1	
50	12921003	SA6263001	油管 φ3×φ5 L=320	OIL TUBE L=320	1	
51	4172302100	SA6260001	油毡组件	FELT ASSY	1	
52	41723009	S00400000	油线 φ2.5 L=200	WICK 2.5×200	1	
53	12921002	SA6579001	油管 φ3×φ5 L=110	OIL TUBE L=110	1	
54	41736002	SA5339101	油嘴管	OIL FEEDING PIPE	1	
55	41711015	525567000	电线夹 #8	CORD HOLDER #8	3	
56	41712075	SA3242001	油毡支架	FELT HOLDER	1	
57	417S15009	S44924001	固定螺钉 M3×5.5	SCREW M3×5.5	2	
58	41711012	SA3274101	油毡支架	FELT HOLDER	1	
59	417S15010	S47307001	螺钉 M3×4	SCREW M3×4	2	
60	12921002	SA6577001	油管 φ3×φ5 L=300	OIL TUBE L=300	1	
61	41711017	552907000	电线夹 #10	CORD HOLDER #10	1	
62	41723014	SA6572001	油线 L=140	WICK L=140	1	
63	41712110	SA6581001	油毡压板 L	WICK SUPPORT L	1	
64	41723024	SA6583001	底板油毡 L	FELT BEDL	1	

F. 供油润滑装置 / Lubrication

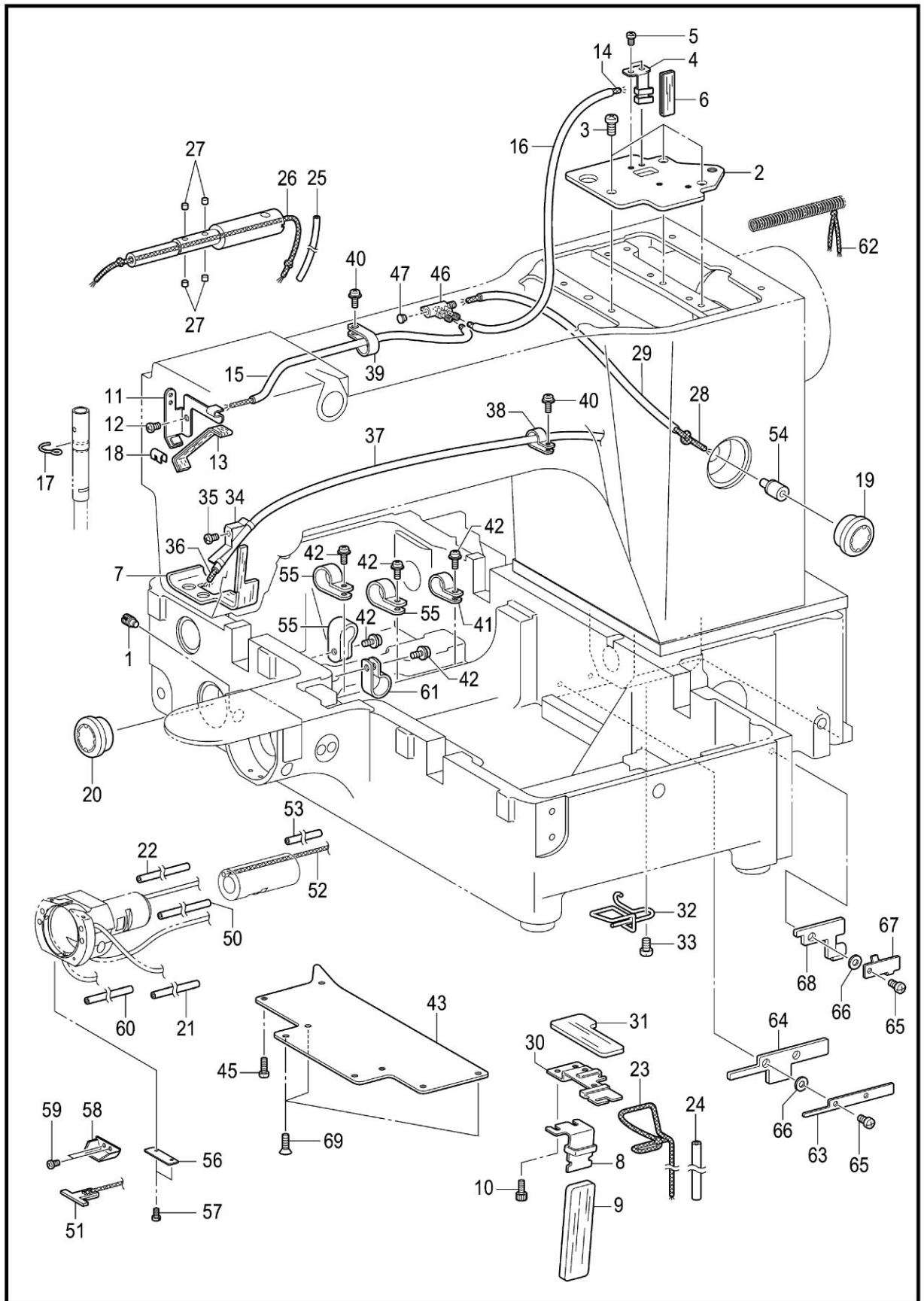

F、供油润滑装置/Lubrication

序号 No.	公司件号 Part. No.	参考件号 Ref. No.	零部件名称	NAME OF PARTS	数量 Amt.	备注
65	S04035	062400616	螺钉 M4×6	SCREW PAN M4×6	3	
66	W02008	028040246	弹簧垫圈 2-4	WASHER SPRING 2-4	3	
67	41712130	SA6582001	油毡压板 R	WICK SUPPORT R	1	
68	41723018	SA6584001	底板油毡 R	FELT BED R	1	
69	S02039	S25310101	螺钉 M4	SCREW FLAT M4	3	

G . 穿线装置 / Threading mechanism

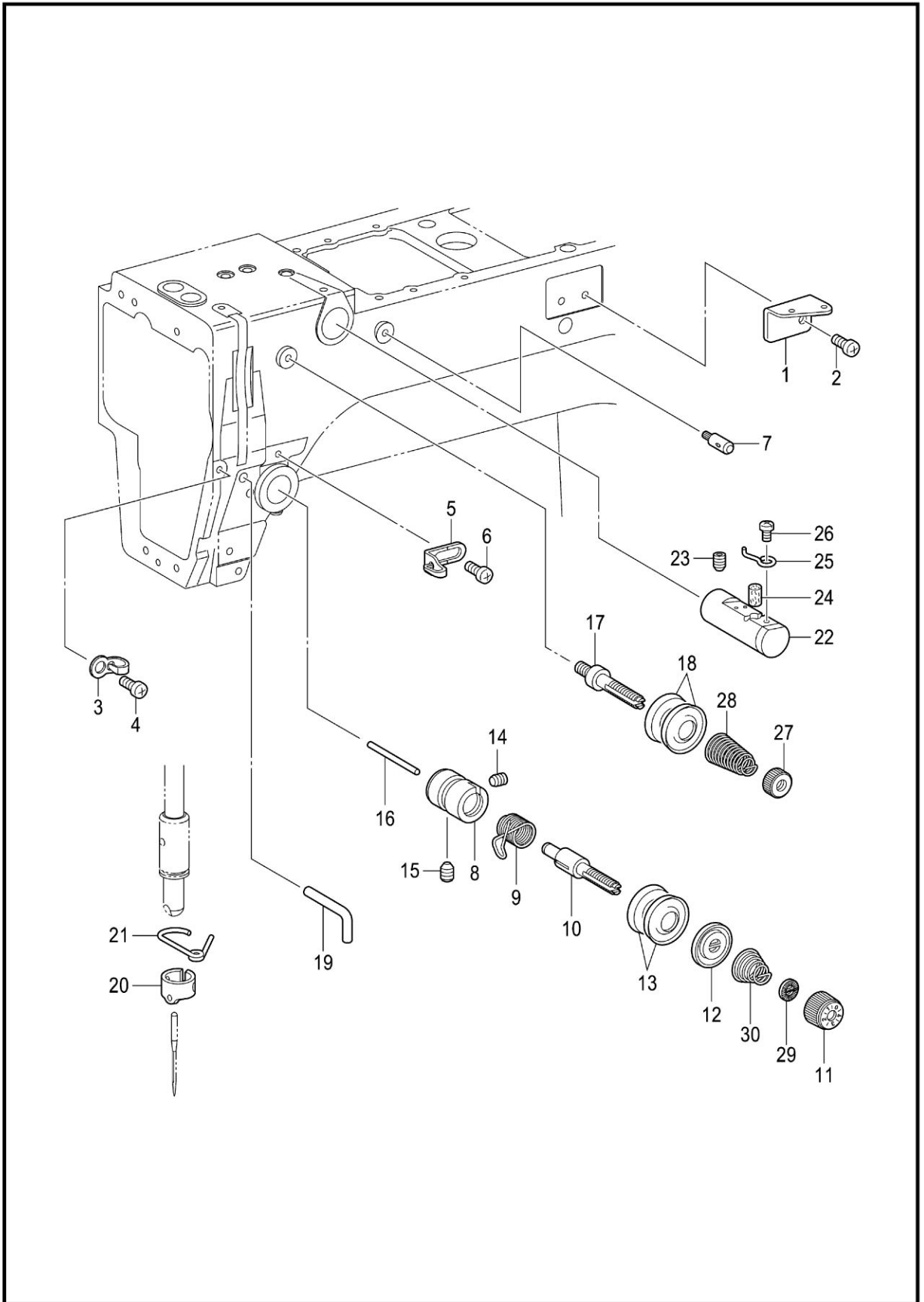

G、穿线装置/Threading mechanism

序号 No.	公司件号 Part. No.	参考件号 Ref. No.	零部件名称	NAME OF PARTS	数量 Amt.	备注
1	41712077	SA3250001	过线导向 A	ARM THREAD GUIDE A	1	
2	S04030	062500616	螺钉 M5×6	SCREW PAN M5×6	1	
3	41712078	SA4333001	过线导向 B	ARM THREAD GUIDE B	1	
4	S04030	062500616	螺钉 M5×6	SCREW PAN M5×6	1	
5	41712079	SA6391001	过线器 C	ARM THREAD GUIDE C	1	
6	S04030	062500616	螺钉 M5×6	SCREW PAN M5×6	1	
7	41702030	153049001	面线导向杆	UPPER THREAD GUIDE STUD	1	
8	41713001	SA3254001	夹线座	TENSION BRACKET	1	
9	41713002	*P. 66	调节弹簧	THREAD TAKE-UP SPRING	1	
10	41713003	SA3255001	夹线杆轴	TENSION STUP	1	
11	129S30013	S31032001	压线螺母	TENSION NUT	1	
12	41713005	159805001	夹线压盘	TENSION DISC PRESSER	1	
13	41713006	145446001	夹线盘	DISC TENSION	1	
14	417S15012	100402004	固定螺钉 SM3. 57	SET SCREW SM3. 75	1	
15	417S10004	SA4143001	螺钉 M6×6	SET SCREW (FT) M6×6	1	
16	41702031	S12699000	松线销	TENSION RELEASE PIN	1	
17	41713007	SA3256001	夹线杆轴 A	TENSION STUD A	1	
18	41713006	145446001	夹线盘	DISC TENSION	2	
19	41712080	159224001	线钩	THREAD GUIDE ARM	1	
20	41726014	*P. 67	针杆线导向	NEEDLE BAR THREAD GUIDE	1	
21	41712082	SA3258001	针杆轴套线导向 D	N-BAR BUSH THREAD GUIDE D	1	
22	41203018	152881001	线冷却器组件	NEEDLE COOLER ASSY	1	
23	S10019	012060636	螺钉 M6×6	SET SCREW SOCKET (FT) M6×6	1	
24	41223043	152883000	油毡 8×15.5	FELT 8×15.5	1	
25	41213008	152884001	过线钩	NEEDLE COOLER THREAD GUIDE	1	
26	409S11017	062670412	螺钉 SM3. 57-40×4	SCREW PAN SM3. 57-40×4	1	
27	41713009	100136001	夹线螺母	TENSION NUT	1	
28	41713010	SA4146001	弹簧	SUB TENSION SPRING	1	
29	41713011	S12441001	止动垫圈	WASHER	1	
30	41713012	*P. 66	夹线簧	TENSION SPRING	1	

H. 卷线装置 / Bobbin winder mechanism

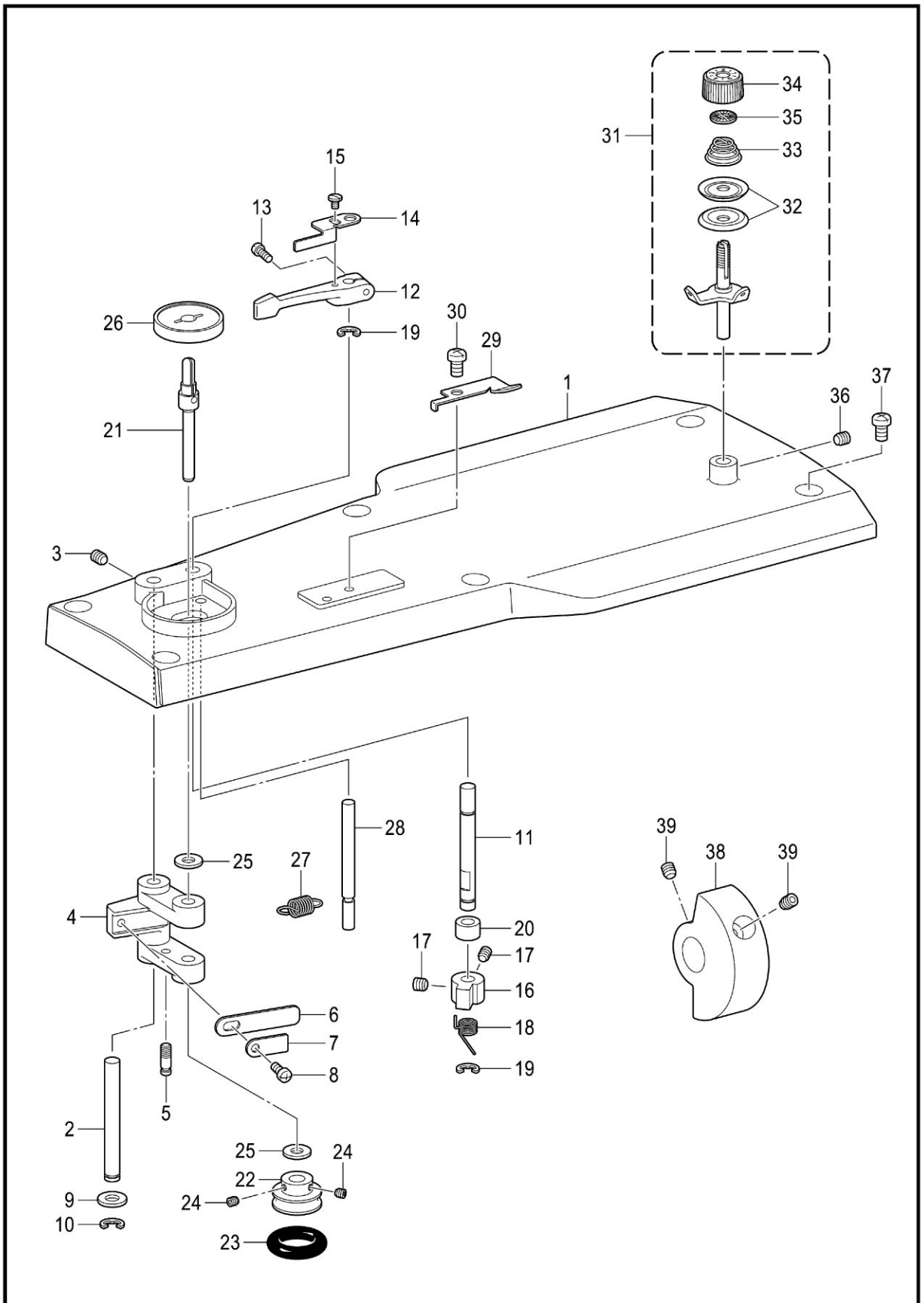

H、卷线装置/Bobbin winder mechanism

序号 No.	公司件号 Part. No.	参考件号 Ref. No.	零部件名称	NAME OF PARTS	数量 Amt.	备注
1	41701010	SA4795001	顶盖	TOP COVER	1	
2	41702033	SA3290001	卷线手柄轴	SHAFT BW-LEVER	1	
3	S09019	012500536	螺钉 M5×5	SET SCREW SOCKET (FT)M5×5	1	
4	41709026	SA3291001	卷线手柄	BOBBIN WINDER LEVER	1	
5	41702034	SA4171001	弹簧挂钩	SPRING HOOK	1	
6	41712084	152936001	板弹簧	PLATE SPRING	1	
7	41712085	152937001	垫圈	WASHER	1	
8	S04077	062350616	螺钉 M3.5×6	SCREW PAN M3.5×6	1	
9	W01015	159486001	垫圈	WASHER	1	
10	H05006	048050342	挡圈 E5	RETAINING RING E5	1	
11	41702035	SA3293001	卷线卡爪轴	STUD B-WINDER	1	
12	41709027	SA1984001	梭芯压臂柄	BOBBINPRESSER ARM	1	
13	S04081	062401216	螺钉 M4×12	SCREW PAN 4×12	1	
14	41712086	SA3294001	梭芯压杆	BOBBIN PRESSER	1	
15	417S15006	S23418002	螺钉 M4×5	SCREW M4×5	1	
16	41709028	SA3295001	卷线卡爪	CLAW B-WINDER	1	
17	S09006	012400436	螺钉 M4×4	SET SCREW SOCKET (FT)M4×4	2	
18	41727007	S10438001	弹簧	SPRING TWIST	1	
19	H05006	048050342	挡圈 E5	RETAINING RING E5	2	
20	41708025	SA4796001	垫片	SPACER COLLER	1	
21	41702036	SA3296001	卷线轴	BOBBIN WINDER SHAFT	1	
22	41703021	SA3297001	卷线器	WHEEL B-WINDER	1	
23	41722017	120448001	橡皮圈	BOBBIN WINDER RUBBER BAND	1	
24	S09006	012400436	螺钉 M4×4	SET SCREW SOCKET (FT)M4×4	2	
25	W01015	159486001	垫圈	WASHER	2	
26	41711063	SA1988001	梭芯座	BOBBIN SUPPORT	1	
27	41727008	S10268001	拉簧	SPRING	1	
28	41702037	SA3298001	止动轴	STPPER SHAFT B-WINDER	1	
29	41719001	SA3299001	切刀	KNIFT	1	
30	S04030	062500616	螺钉 M5×6	SCREW PAN M5×6	1	
31	1291301100	SA1994101	卷线器夹线组件	BOBBIN WINDER TENSION ASSY	1	
32	12913007	145446002	夹线盘	DISC TENSION	2	
33	12927016	100401022	夹线弹簧	TENSION SPRING	1	
34	129S30013	S31032001	压线螺母	TENSTON NUT	1	
35	12928014	S12441001	止动垫圈	WASHER	1	
36	S09019	012500536	螺钉 M5×5	SET SCREW SOCKET (FT)M5×5	1	
37	S04038	062061016	螺钉 M6×10	SCREW PAN M6×10	6	
38	41704002	SA4797101	卷线驱动轮	DRIVING WHEEL B-WINDER	1	
39	S10018	S23651001	固定螺钉 M6×0.75-6	SET SCREW SOCKET (FT)M6×6	2	

J . 切线装置 / Thread trimmer mechanism

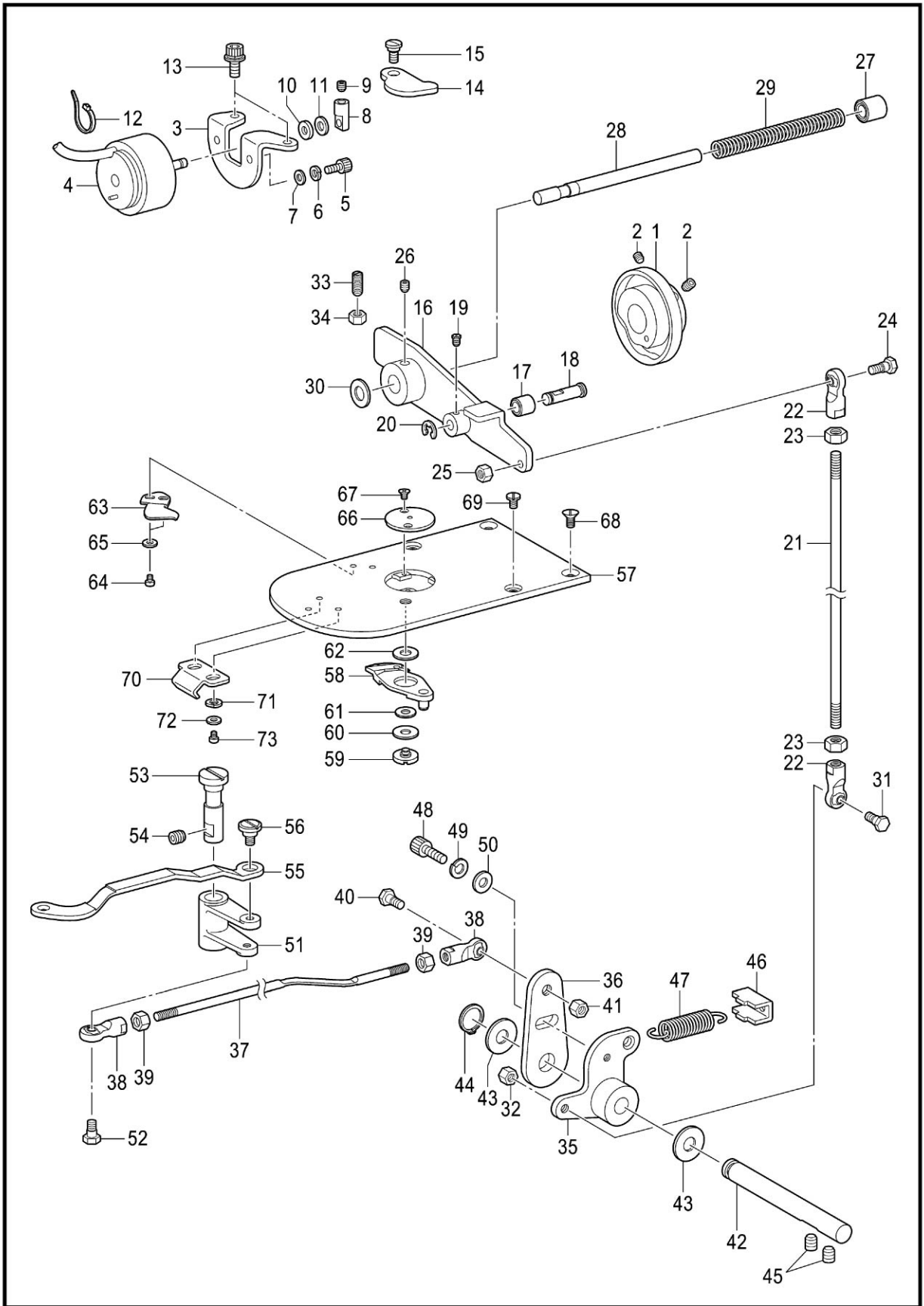

J、切线装置/Thread trimmer mechanism

序号 No.	公司件号 Part. No.	参考件号 Ref. No.	零部件名称	NAME OF PARTS	数量 Amt.	备注
1	41710003	SA3301101	切线凸轮	THREAD TRIMMER CAM	1	
2	S10018	S23651001	固定螺钉 M6×0.75-6	SET SCREW SOCKET (FT)M6×6	2	
3	41712087	SA4798001	电磁铁安装板	SETTING PLATE SOLENOID	1	
4	41730001	SA5135001	切线电磁铁	THREAD TRIMMER SOLENOID	1	
5	L02031	017400802	螺栓 M4×8	BOLT M4×8	2	
6	W02008	028040246	弹簧垫圈 2-4	WASHER SPRING 2-4	2	
7	W01001	025040236	平垫圈 M4	WASHER PLAIN M4	2	
8	41702038	SA3307001	电磁铁杆	SOLENOID LEVER	1	
9	S09006	012400436	螺钉 M4×4	SET SCREW SOCKET (FT)M4×4	1	
10	41722020	154599000	电磁铁缓冲垫圈	SOLENOID CUSHION	1	
11	41728033	S02445001	垫圈	WASHER	1	
12	11211005	S04159000	线夹 1M	BAND 1M	1	
13	417S30035	S55484002	螺栓 (带垫圈) M5×10	BOLT SCREW SOCKET (S/P WASHER)M5×10	2	
14	41712088	SA4799001	驱动压杆	PUSHING LEVER D-LEVER	1	
15	417S30012	SA3306001	段螺钉 7-3	SHOULDER SCREW 7-3	1	
16	4171211100	SA3309101	切线驱动杆组件	TR-DRIVING LEVER	1	
17	41703022	SA3310001	切线滚轮	COLLAR TR-TRIMMER	1	
18	41702039	SA3311001	切线滚轮轴	COLLAR SHAFT	1	
19	417S12009	S46903001	螺钉 M4×5	SET SCREW M4×5	1	
20	H05029	048040342	挡圈 E4	RETAINING RING E4	1	
21	41702040	SA3315001	切线杆 V	THREAD TRIMMER RODV	1	
22	4170500300	S32465001	接头组件	BALL JOINT ASSY	2	
23	N01021	021060106	螺母 M6	NUT 1 M6	2	
24	417S12005	S32462001	段螺钉B M6	SHOULDER SCREW B M6	1	
25	N01012	021060306	六角螺母 M6	NUT 3 M6	1	
26	S10018	S23651001	固定螺钉 M6×0.75-6	SET SCREW SOCKET (FT)M6×6	1	
27	41703023	231071001	轴套 8×15	BUSH 8×15	1	
28	41702041	SA3312001	驱动杆导向轴	GUIDE SHAFT	1	
29	41727009	SA3313101	弹簧	SPRING COMPRESSION	1	
30	41722018	154596000	减震垫圈	CUSHION	1	
31	417S12005	S32462001	段螺钉B M6	SHOULDER SCREW B M6	1	
32	N01012	021060306	六角螺母 M6	NUT 3 M6	1	
33	417S10003	S25475101	螺钉 M6×19	SET SCREW M6×19	1	
34	N01021	021060106	螺母 M6	NUT 1 M6	1	
35	41712089	SA4546001	切线杠杆 V	THREAD TRIMMER LEVER V	1	
36	41712090	SA3317001	切线杠杆 H	THREAD TRIMMER LEVER H	1	
37	41712091	SA4801001	切线杆 H	THREAD TRIMMER ROD H	1	
38	4170500300	S32465001	接头组件	BALL JOINT ASSY	2	
39	N01021	021060106	螺母 M6	NUT 1 M6	2	
40	417S12005	S32462001	段螺钉B M6	SHOULDER SCREW B M6	1	
41	N01012	021060306	六角螺母 M6	NUT 3 M6	1	
42	41702042	SA3319101	切线杠杆轴	SHAFT TR-TRIMMER LEVER	1	
43	41728023	SA4545001	垫片	SPACER	2	
44	H03006	048080142	轴用挡圈 C8	RETAINING RING EXTERNAL C8	1	
45	S10019	012060636	螺钉 M6×6	SET SCREW SOCKET (FT)M6×6	2	
46	41712092	SA3320101	弹簧挂钩	SPRING HOOK	1	
47	41727010	SA3321001	切线复位弹簧	SPRING EXTENSION	1	
48	S05123	018501236	螺栓 M5×12	BOLT SOCKET M5×12	1	
49	W02001	028050246	弹簧垫圈 2-5	WASHER SPRING 2-5	1	
50	41728028	146354002	垫圈 5	WASHER PLAIN 5	1	
51	41709029	SA3324001	动刀曲柄	MOVING KNIFE LEVER	1	
52	417S12007	SA3325001	段螺钉 6.35-6	SHOULDER SCREW 6.35-6	1	
53	41702043	SA4802001	动刀杆轴	SHAFT MOVABLE KNIFE LEVER	1	
54	S10019	012060636	螺钉 M6×6	SET SCREW SOCKET (FT)M6×6	1	
55	41712093	SA3327101	动刀连杆	M-KNIFE CONNECTING PLATE	1	
56	417S30013	SA4354001	段螺钉 6-1.8	SHOULDER SCREW 6-1.8	1	
57	41715001	SA5157001	针板A	NEEDLE PLATE A	1	
58	4170903000	SA3330001	动刀组件 F	MOVABLE KNIFE ASSY F	1	
59	417S30014	SA4518001	段螺钉	MOVABLE KNIFE SHOULDER SCREW	1	
60	41728007	SA4519001	动刀圈套	THRUST WASHER	1	
61	41728008	S00705001	动刀圈套	MOVABLE KNIFE COLLAR	1	

J . 切线装置 / Thread trimmer mechanism

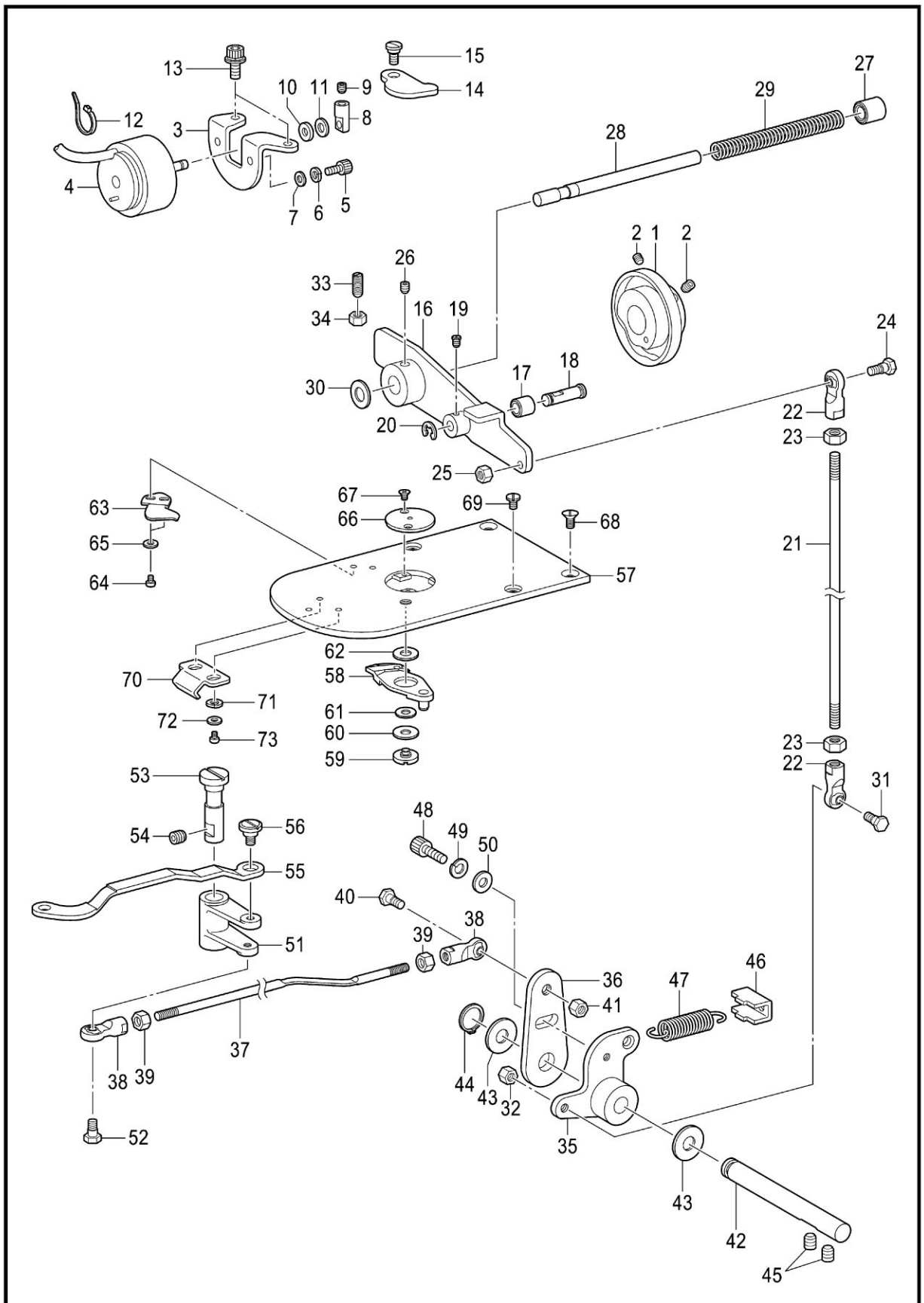

J、切线装置/Thread trimmer mechanism

序号 No.	公司件号 Part. No.	参考件号 Ref. No.	零部件名称	NAME OF PARTS	数量 Amt.	备注
62	41728009	SA6297001	垫片 0.2	M-KNIFE SPACER T0.2	1	
62	41728009	SA3334001	垫片 0.3	M-KNIFE SPACER T0.3	1	
62	41728009	SA6398001	垫片 0.4	M-KNIFE SPACER T0.4	1	
63	41719002	SA3335001	定刀 F	FIXED KNIFE F	1	
64	S04036	062300416	螺钉 M3×4	SCREW PAN M3×4	2	
65	W01002	026030236	垫圈 M3	WASHER PLAIN M3	2	
66	41712094	*P.66	针孔板	NEEDLE HOLE PLATE	1	
67	417S17001	100360003	螺钉 SM2.38	SCREW	2	
68	S02039	S25310101	螺钉 M4	SCREW FLAT M4	2	
69	417S15008	SA3538001	螺钉 M4×8	SCREW M4×8	2	
70	41712095	SA6273001	大旋梭盖挂钩 U	SHUTTLE BASE COVER HOOK U	1	
71	W02007	028030246	弹簧垫圈 2-3	WASHER SPRING 2-3	2	
72	W01002	026030236	垫圈 M3	WASHER PLAIN M3	2	
73	S04036	062300416	螺钉 M3×4	SCREW PAN M3×4	2	

K . 扫线装置 / Thread wiper mechanism

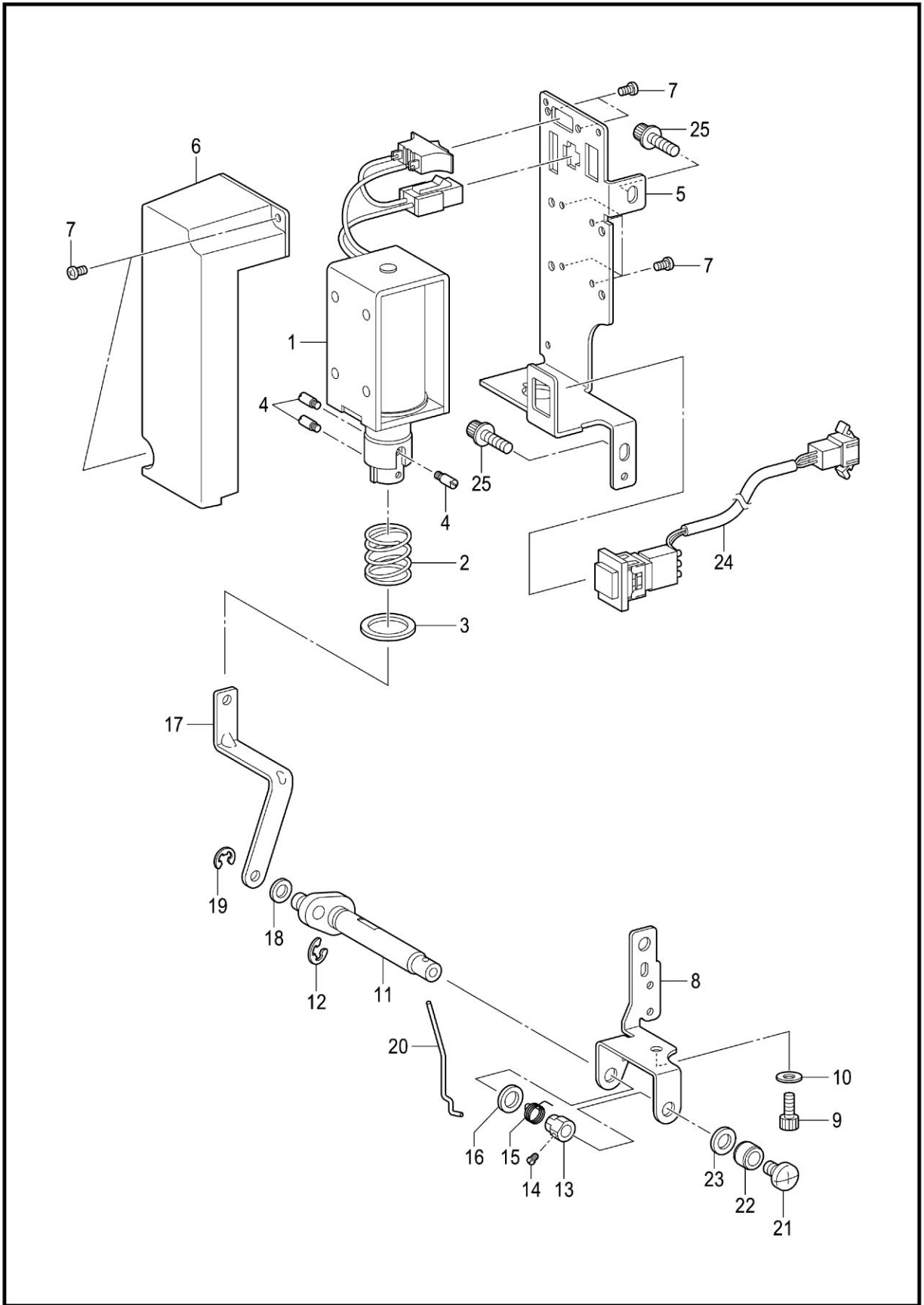

K、扫线装置/Thread wiper mechanism

序号 No.	公司件号 Part. No.	参考件号 Ref. No.	零部件名称	NAME OF PARTS	数量 Amt.	备注
1	41730002	SA5208001	扫线电磁铁组件	THREAD WIPER SOLENOID ASSY	1	
2	41727011	S41206001	挡线弹簧	THREAD WIPER SPRING	1	
3	41728011	S41205001	平垫圈	WASHER PLAIN	1	
4	41726007	S25456001	柱塞销	PLUNGER PIN	3	
5	41712210	SA5217001	扫线电磁铁安装板	T-WIPER SOLENOID SETTING PLATE	1	
6	41711011	SA4806001	电磁铁盖	SOLENOID COVER	1	
7	S04082	062300616	螺钉 M3×6	SCREW PAN M3×4	8	
8	41712096	SA5218001	扫线轴托架	THREAD WIPER SHAFT BRACKET	1	
9	S05116	018400836	螺栓 M4×8	BOLT SOCKET M4×8	1	
10	W01001	025040236	平垫圈 M4	WASHER PLAN M4	1	
11	4170204400	SA1967001	扫线曲柄组件	THREAD WIPER CRANK ASSY	1	
12	H05029	048040342	挡圈 E4	RETAINING RING E4	1	
13	41708007	S25454001	螺纹紧圈	SET SCREW COLLAR	1	
14	417S15005	S25279001	螺钉 M3.5-5	SET SCREW (CP)M3.5-5	1	
15	41727012	SA2287001	扭簧	SPRING	1	
16	41722019	149097000	消音垫	SILENT SHEET	1	
17	41712097	SA5219001	扫线杆	THREAD WIPER ROD	1	
18	W01024	110735001	垫圈	WASHER	1	
19	H05002	048030342	挡圈 E3	RETAINING RING E3	1	
20	41712098	S10470101	扫线钢丝	WIPER	1	
21	417S15013	060400516	螺钉 M4×5	SCREW BIND M4×5	1	
22	41708008	146288001	挡线轴挡圈	THREAD WIPER STUD COLLAR	1	
23	41728034	S03677001	垫圈	WASHER	1	
24	41730003	SA5213001	停止开关组件	STOP SWITCH ASSY	1	
25	417S30036	S55485001	螺栓 (带垫圈) M5×12	BOLT SOCKET (S/P WASHER)M5×12	2	

L . 松线装置 / Tension release mechanism

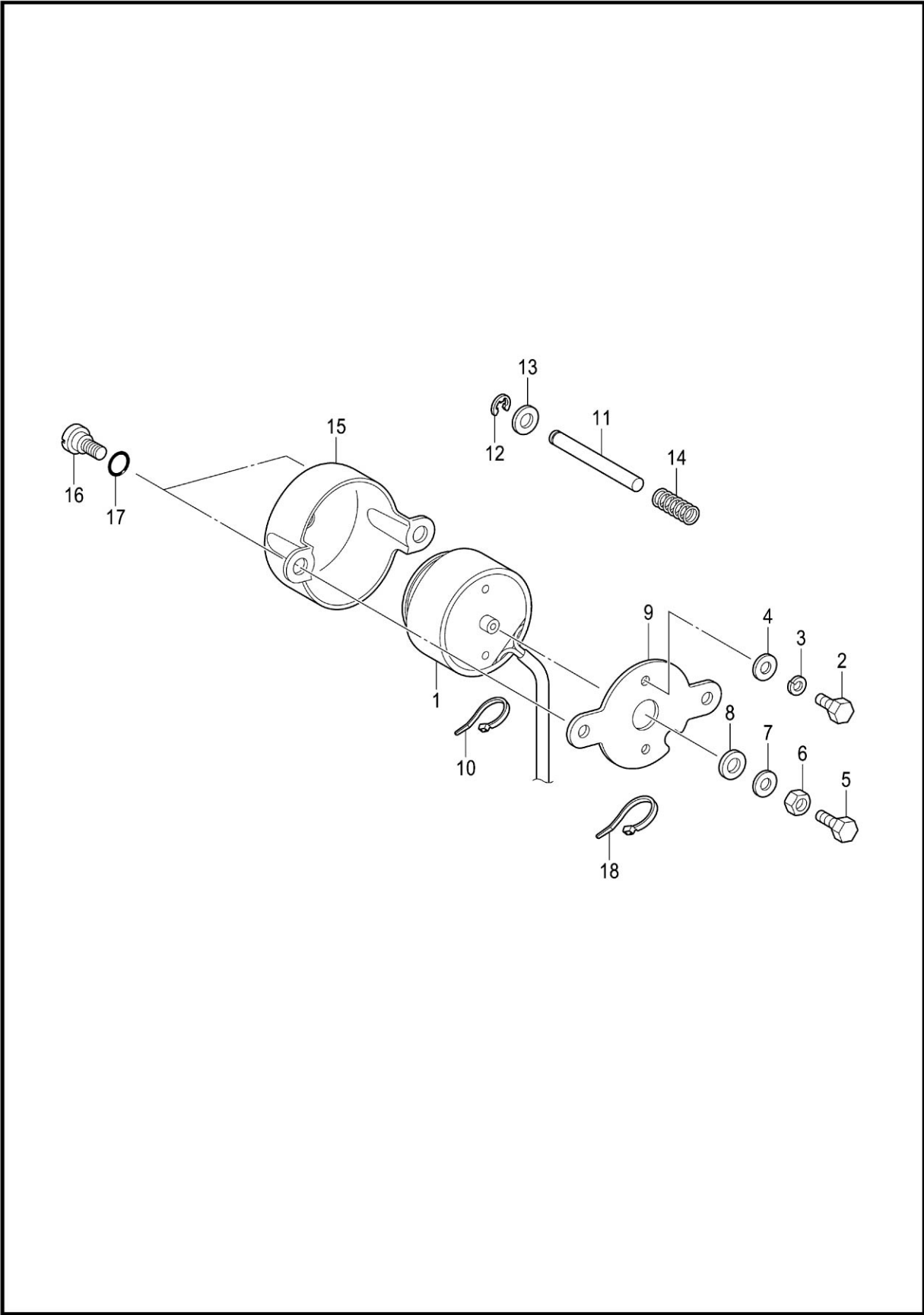

L、松线装置/Tension release mechanism

序号 No.	公司件号 Part. No.	参考件号 Ref. No.	零部件名称	NAME OF PARTS	数量 Amt.	备注
1	41730004	SA4855001	松线电磁铁HV	TENSION RELEASE SOLENOID HV	1	
2	L02031	017400802	螺栓 M4×8	BOLT M4×8	2	
3	W02008	028040246	弹簧垫圈 2-4	WASHER SPRING 2-4	2	
4	W01001	025040236	平垫圈 M4	WASHER PLAIN M4	2	
5	L02036	017401415	螺栓 M4×14	BOLT M4×14	1	
6	N01024	021400306	六角螺母 M4	NUT 3 M4	1	
7	W01001	025040236	平垫圈 M4	WASHER PLAIN M4	1	
8	41722020	154599000	电磁铁缓冲垫圈	SOLENOID CUSHION	1	
9	41712099	SA6389001	电磁铁安装板	SETTING PLATE SOLENOID	1	
10	11211005	S04159000	线夹 1M	BAND 1M	1	
11	41702045	SA3347001	松线杆	TENSION RELEASE BAR	1	
12	H05029	048040342	挡圈 E4	RETAINING RING E4	1	
13	W01009	025050236	平垫圈 M5	WASHER PLAIN M5	1	
14	41727013	SA3348001	弹簧	SPRING COMPRESSION	1	
15	41711013	SA3349001	电磁铁盖	SOLENOID COVER	1	
16	417S30012	SA3306001	段螺钉 7-3	SHOULDE SCREW 7-3	2	
17	41722021	081007070	O形圈 P7	O RING P7	2	
18	11211005	218859001	电线夹 M150	BINDER M150	1	

P . 空压装置 / Air pressure mechanism

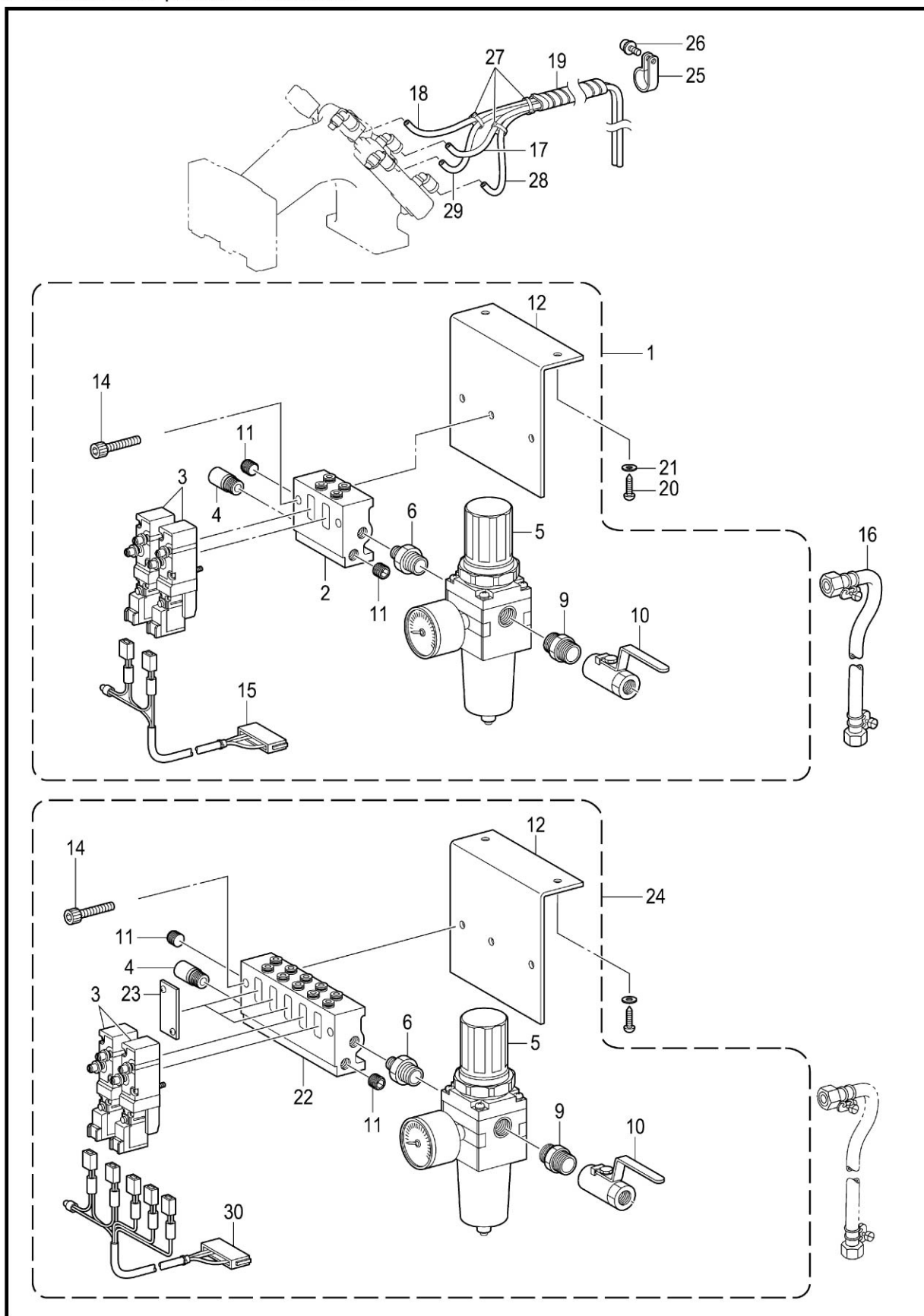

P、空压装置/Air pressure mechanism

序号 No.	公司件号 Part. No.	参考件号 Ref. No.	零部件名称	NAME OF PARTS	数量 Amt.	备注
			<空压式>	<For Pneumatic type>		
1	4173001100	SA5281001	电磁阀组件 2A	SOLENOID VALVE ASSY 2A	1	
2	40730028	SA5289001	双通汇流板	MANIFOLD2	1	
3	40730082	S39116100	电磁阀 SY3120-5L0ZD-C4	VALVE SY3120-5L0ZD-C4	2	
4	40728003	SA5283001	消声器	SILENCER	1	
5	40730024	SA5282001	气压阀	AIR VALVE	1	
6	417S30026	S09228000	管接头	JOINT	1	
10	40730046	SA6573001	手动阀	VALVE	1	
11	407S12002	153274001	汇流板密封螺钉	SCREW	3	
12	41712106	SA5286001	阀安装板	SETTING PLATE VALVE	1	
14	417S30024	018503036	螺栓 M5×30	BOLT SOCKET M5×30	2	
15	41730022	SA5191001	阀门接线2连组件	VALVE HARNESS X2 ASSY	2	
16	4073001000	149796001	橡皮管带接头	AIR HOSE, W/CONNECTOR	1	
17	61911006	SA6405001	空气管 R	AIR TUBE R	1	
18	61911006	SA6406001	空气管 L	AIR TUBE L	1	
28	61911006	SA6405002	空气管 R	AIR TUBE R	1	
29	61911006	SA6406002	空气管 L	AIR TUBE L	1	
19	41711008	SA6407001	保护用弹性管 470S (φ12)	SPIRAL 470S	1	
20	417S30015	032422003	木螺钉 M4.1×20	WOOD SCREW, ROUND 2 M4.1×20	2	
21	W01001	025040236	平垫圈 M4	WASHER PLAIN M4	2	
25	41711016	525664000	电线夹 #6	CORD HOLDER, #6	1	
26	417S30025	0A5401006	螺栓 (带垫圈) M4×10DB	SCREW PAN (S/P WASHER) M4×10	1	
27	11211005	228475000	电线夹 1.9×80	FASTENING BAND, 1.9×80	3	
24	4173003100	SA5288001	电磁阀组件 5A	SOLENOID VALVE ASSY 5A	1	
22	41730032	SA5290001	集合管 5	CORD HOLDER #5	1	
23	41730033	S53982000	隔板	BLANKING PLATE ASSY	3	
3	40730082	S39116100	电磁阀 SY3120-5L0ZD-C4	VALVE SY3120-5L0ZD-C4	2	
4	40728003	SA5283001	消声器	SILENCER	1	
5	40730045	SA5282001	气压阀	AIR VALVE	1	
6	417S30026	S09228000	管接头	JOINT	1	
10	40730046	SA6573001	手动阀	VALVE	2	
11	407S12002	153274001	汇流板密封螺钉	SCREW	1	
12	41712106	SA5286001	阀安装板	SETTING PLATE VALVE	2	
14	417S30024	018503036	螺栓 M5×30	BOLT SOCKET M5×30	2	
30	41730031	SA5192001	阀门接线5连组件	VALVE HARNESS X5 ASSY	1	

Q . 电气部品装置 / Power supply equipment mechanism

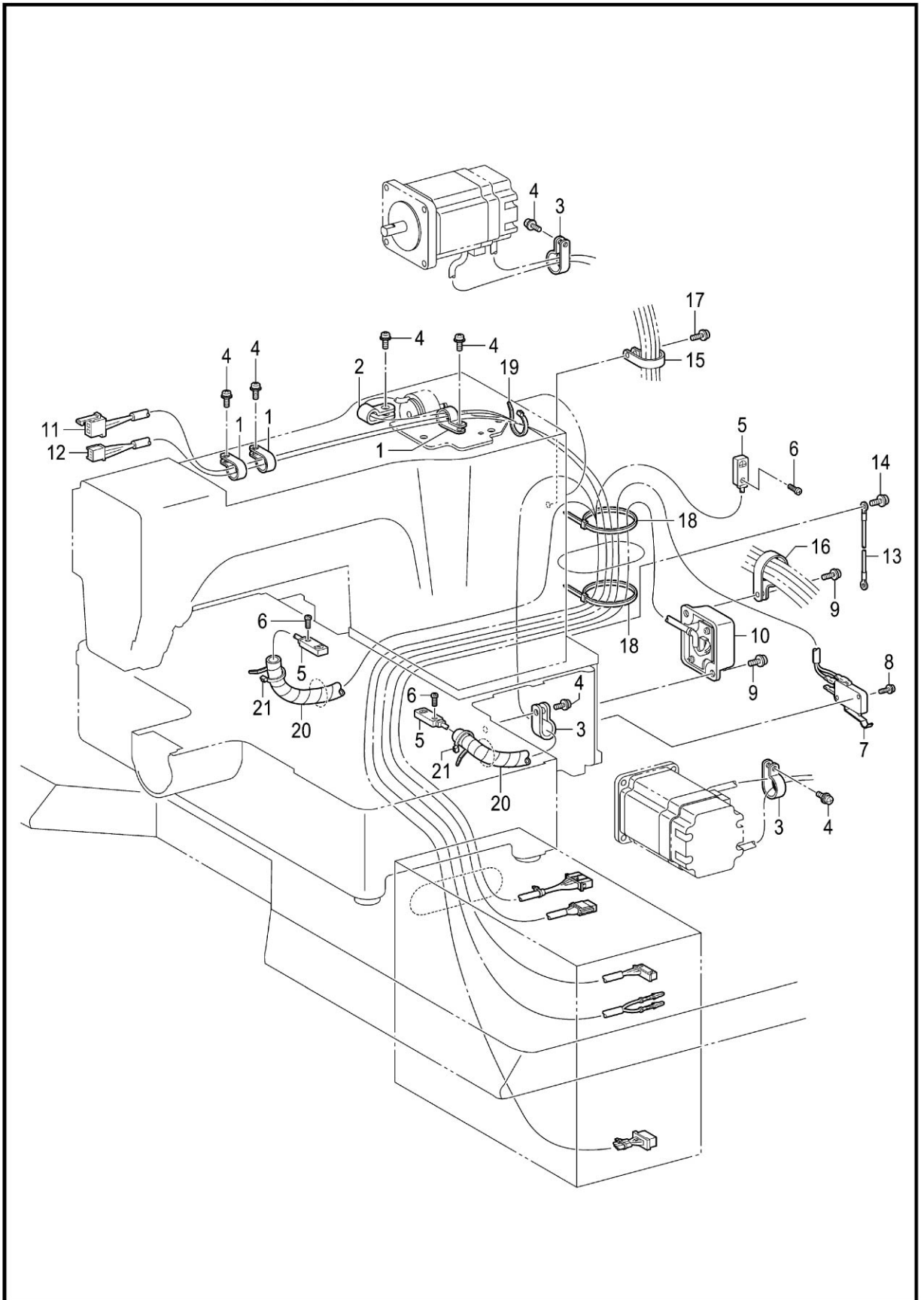

Q、电气部品装置/Power supply equipment mechanism

序号 No.	公司件号 Part. No.	参考件号 Ref. No.	零部件名称	NAME OF PARTS	数量 Amt.	备注
1	41711015	525567000	电线夹 #8	CORD HOLDER #8	3	
2	41711014	149547000	压线板	CORD HOLDER 4N	1	
3	41711015	525567000	电线夹 #8	CORD HOLDER #8	3	
4	417S30025	0A5401006	螺栓 (带垫圈) M4×10DB	SCREW PAN(S/P WASHER)M4×10DB	7	
5	4173000500	SA4830001	传感器组件	H-POSITION SENSOR ASSY	2	
6	S04076	062300816	螺钉 M3×8	SCREW PAN M3×8	2	
7	41730006	SA3481001	机头开关组件	SWITCH ASSY MACHINE HEAD	1	
8	417S30023	0A5301605	螺栓 (带垫圈) M3×16DB	SCREW PAN(S/PWASHER)M4×16DB	2	
9	417S30025	0A5401006	螺栓 (带垫圈) M4×10DB	SCREW PAN(S/PWASHER)M4×10DB	2	
10	41730030	SA4824001	头部检出复合件	HEAD DETECTOR UNIT ASSY	1	
11	41730007	SA5210001	电磁铁接线	THREAD WIPER SOLENOID HARNESS	1	
12	41730008	SA5214001	开关接线	STOP SWITCH HARNESS	1	
13	41730009	SA5261001	接底线 450	GROUND WIRE 450	1	
14	417S30025	0A5401006	螺栓 (带垫圈) M4×10DB	SCREW PAN(S/P WASHER)M4×10DB	1	
15	41711025	554482000	电线夹 #12	CORD HOLDER #12	1	
16	41711025	554482000	电线夹 #12	CORD HOLDER #12	1	
17	417S30025	0A5401006	螺栓 (带垫圈) M4×10DB	SCREW PAN(S/P WASHER)M4×10	2	
18	41711019	218859001	电线夹 M150	BINDER M150	2	
19	11211005	S04159000	线夹 1M	BAND 1M	1	
20	41711009	SA6560101	保护用螺旋管 140SS (Φ	SPIRAL 140SS	2	
21	11211005	S04159000	线夹 1M	BAND 1M	2	

S . 马达装置 / Motor mechanism

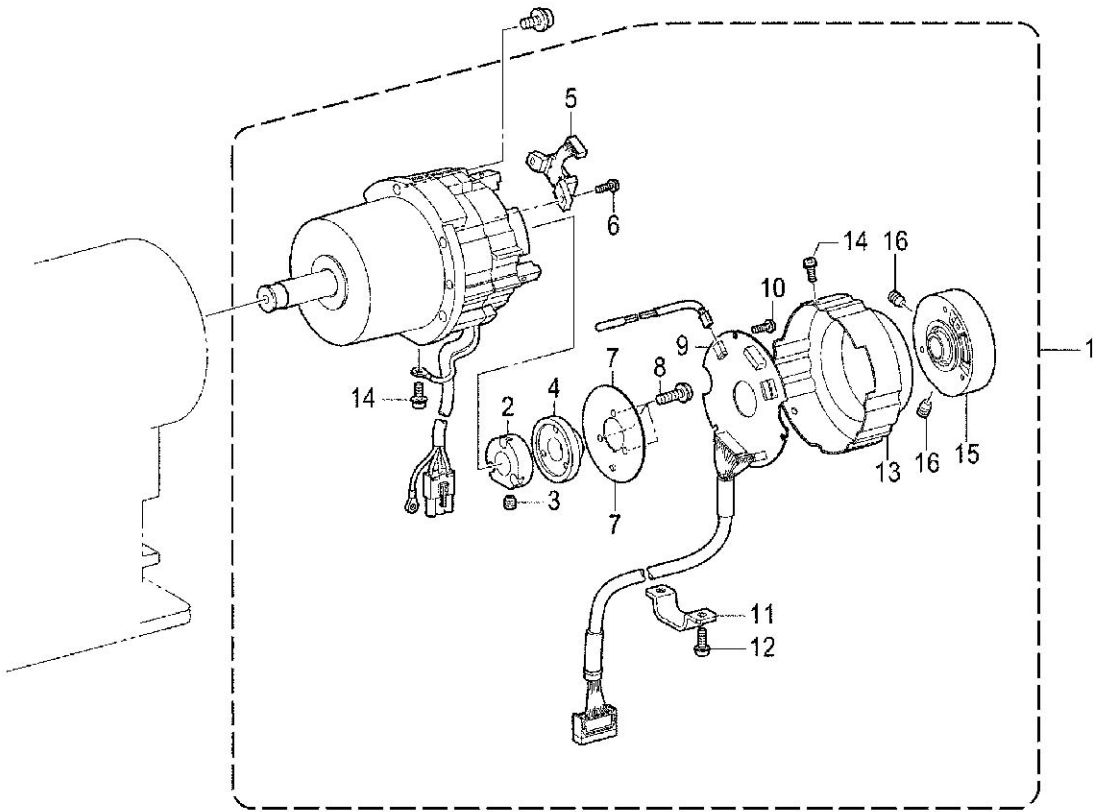

5、马达装置/Motor mechanism

序号 No.	公司件号 Part. No.	参考件号 Ref. No.	零部件名称	NAME OF PARTS	数量 Amt.	备注
1	41730047	J80991001	马达组件 CDD-430D	MOTOR ASSY CDD-430D	1	
2	41730048	J03955001	磁鼓 CDD	DRUM CDD	1	
3	S09044	014400632	螺钉 M4×6	SET SCREW SOCKET (CP)M4×6	1	
4	41730049	J03956001	磁铁 180P36	MAGNET 180P36	1	
5	41730050	J03957001	MR感应器组件 180P	MR SENSOR ASSY 180P	1	
6	S13003	0A4300805	螺栓(带垫圈) M3×8DA	SCREW PAN(S/P WASHER)M3×8	1	
7	41730051	J03958001	屏蔽板CDD	SHIELD PLATE CDD	1	
8	417S30017	0A4261005	螺栓(带垫圈) M2.6×10	SCREW PAN(S/P WASHER)M2.6×10	3	
9	41730052	J04488001	ENC 基板组件 430#2	ENC PCB ASSY 430D#2	1	
10	417S30018	0A5300606	螺栓(带垫圈) M3×6DB	SCREW PAN(S/P WASHER)M3×6	3	
11	41712118	J04230001	电线固定夹CDD-IIT	CORD HOLDER CDD-IIT	1	
12	417S30019	0A4401005	螺栓(带垫圈) M4×10DA	SCREW PAN(S/P WASHER)M4×10	3	
13	41730053	J04388001	编码器盖 430D	ENCODER COVER 430D	1	
14	S13003	0A4300805	螺栓(带垫圈) M3×8DA	SCREW PAN(S/P WASHER)M3×8	3	
15	41709003	J04303001	同步轮组件 430D	PULLEY HOLDER ASSY 430D	1	
16	S09045	014500632	螺钉 M5×6	SET SCREW SOCKET (CP)M5×6	2	

T. 踏板关系 / Foot switch pedal mechanism

< 电磁式 / For solenoid type >

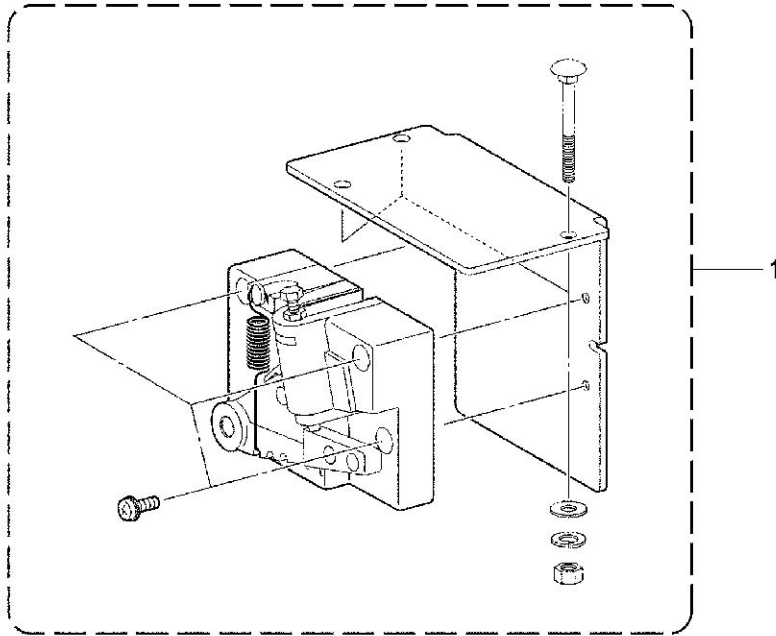

< 空压式 / For Pneumatic type >

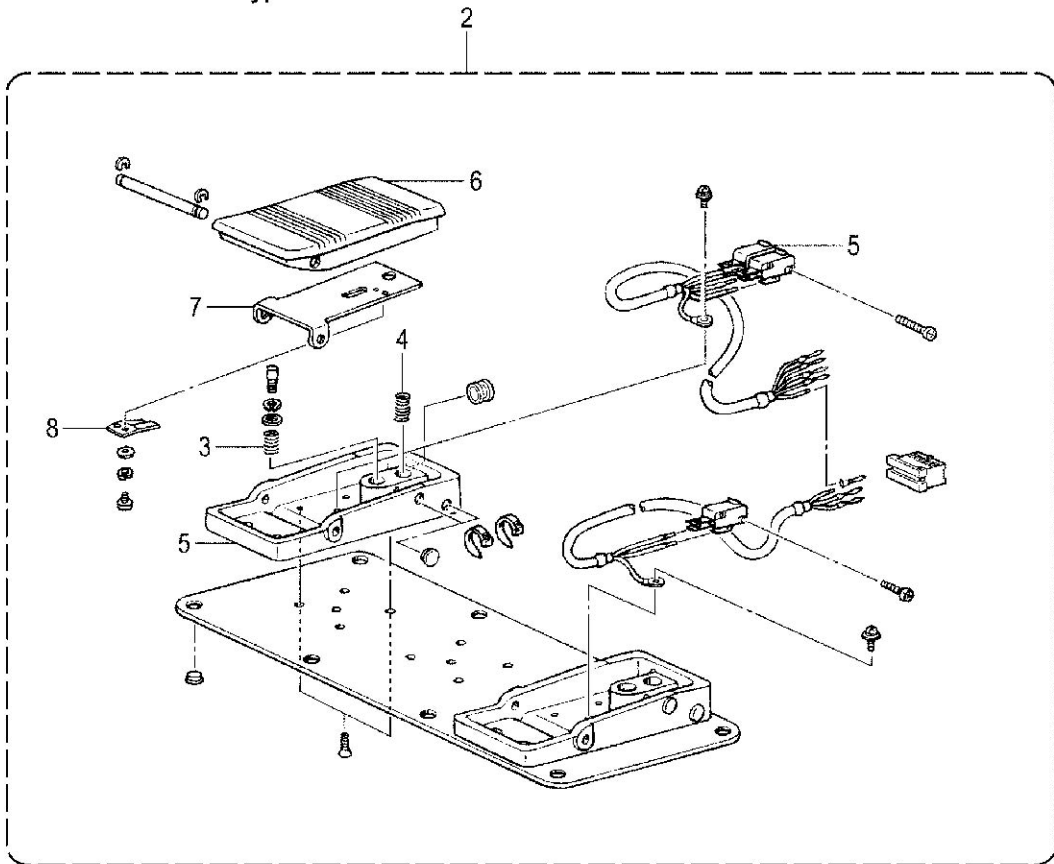

T、踏板关系/Foot switch pedal mechanism

序号 No.	公司件号 Part. No.	参考件号 Ref. No.	零部件名称	NAME OF PARTS	数量 Amt.	备注
			<电磁式>	<For Solenoid type>		
1	4173004200	SA3519101	脚踏复合件 A	TREADLE UINT. A ASSY	1	
			<空压式>	<For Pneumatic type>		
2	4173004500	SA6038001	2连脚踏开关组件	2-PEDAL FOOT SWITCH SW ASSY	1	
3	41727018	S38168001	弹簧	SPRING COMPRESSION 10×30	1	
4	41727018	S38170001	弹簧	FOOT PEDAL SPRING	2	
5	41730046	S36260000	开关 VX	PIK BUTTON MICRO SWITCH VX	3	
6	41712115	S38174000	脚踏板	FOOT PEDAL	2	
7	41712116	S38175001	脚踏护板	PROTECTION PLATE PEDAL	2	
8	41712117	S38176101	弹簧板	SPRING PLATE	2	

Z、附件/Accessories

序号 No.	公司件号 Part. No.	参考件号 Ref. No.	零部件名称	NAME OF PARTS	数量 Amt.	备注
1	41711060	SA4842001	马达盖	MOTOR COVER	1	
3	S04038	062061016	螺钉 M6×10	SCREW PAN M6×10	4	
4	41711031	SA4841001	油盘	OIL PAN	1	
5	41711006	154167001	废油回收壶盖	DUST OILER	1	
6	417S30010	037301215	螺销 M3×12	TAPPING SCREW PAN V M3×12	2	
7	41722005	SA3540001	缓冲橡皮垫	RUBBER CUSHION	3	
8	101S30010	109714000	钉	NAIL	7	
9	11631008	114486002	油壶	OILER	1	
10	20131076	122991001	附属品塑料袋	ACCESSORY BAG	1	
11	20131038	S06706001	硅油	SILICONE OIL	1	
12	41718004	S44633001	梭芯 LAN	BOBBIN LAN	3	
13	40319006	*P. 67	机针组件 (4支装)	NEEDLE 4PIECE ASSY	1	
14	40319006	*P. 67	机针	NEEDLE	4	
15	11631008	114183002	油壶组件	OILER ASSY	1	
16	20131037	S55663001	油罐组件	OIL TANK ASSY	1	
17	10131004	142413001	小起子 1.9×52	SCREW-DRIVER 1.9×52	1	
18	10131003	118837001	起子 3.4×70	SCREW-DRIVER 3.4×70	1	
19	10131002	101572102	起子 5.5×190	SCREW-DRIVER 5.5×190	1	
20	30131005	107779001	扳手 6×7	WRENCH 6×7	1	
21	41731011	100887001	双头扳手 8×9	WRENCH 8×9	1	
22	11631003	107780001	扳手 10×12	WRENCH 10×12	1	
23	30131007	S07783001	内六角扳手 1.5	HEXAGONAL WRENCH 1.5	1	
24	20131046	142002001	内六角扳手 2	HEXAGONAL WRENCH 2	1	
25	30131010	154125001	内六角扳手 2.5	HEXAGONAL WRENCH 2.5	1	
26	30131012	142721001	内六角扳手 3	HEXAGONAL WRENCH 3	1	
27	20131047	118064001	内六角扳手 4	HEXAGONAL WRENCH 4	1	
28	20131056	150335001	内六角扳手 5	HEXAGONAL WRENCH 5	1	
29	1013100700	S40574209	线架组件 2DTHF	COTTON STAND ASSY 2DTHF	1	
76	30112024	200190001	U形卡钉	STAPLE 10×20	7	
78	40131017	144226001	机头罩	HEAD COVER	1	
79	S05088	032461606	螺栓 M6×45	BOLT SOCKET M6×45	4	
82	417S30016	032461606	木螺钉 M4.5×16	WOOD SCREW ROUND 2 M4.5×16	2	
83	4121208100	S44483001	铰链组件	HINGE ASSY	1	
84	41212082	S44484001	护眼板铰链	EYE GUARD HINGE	1	
88	41211005	S44485001	护眼板	EYE GUARD	1	
89	412S17004	061660806	螺钉 SM3.18-40×8	SCREW FLAT SM3.18-40×8	2	
90	412S16012	021660102	螺母 M3.18	NUT M3.18	2	
91	41228047	026030232	平垫圈 M3	WASHER PLAIN M3	2	
92	41211005	S44486101	护眼板架 A	EYE GUARD HOLDER A	2	
93	401S11022	062670512	螺钉 SM3.57-40×5	SCREW PAN SM3.57-40×5	2	
94	S04035	062400616	螺钉 M4×6	SCREW PAN M4×6	2	
95	W01024	110735001	垫圈	WASHER	2	
97	41722033	SA3395001	橡皮铰链	RUBBER CLSHION	2	
98	41712131	SA3392001	垫片	SPACER	2	
99	41726019	SA3384001	机头支承销	PIN	2	
100	S10019	012060636	螺钉 M6×6	SET SCREW SOCKET (CP)M6×6	2	
101	41712132	SA3385001	头部铰链座	HINGE HOLDER	2	
102	S05112	018066036	螺栓 M6×60	BOLT SOCKET M6×60	4	
103	41728030	213650001	垫圈 2.3×8.5×38	WASHER 2.3×8.5×38	4	
105	N01021	021060106	螺母 M6	NUT 1 M6	4	
106	41722005	SA3540001	缓冲橡皮垫	RUBBER CUSHION	4	
107	41730010	SA4845001	缓冲器	SHOCK ABSORBER GAS	1	
108	41712113	SA4846001	缓冲器支架	HOLDER ABSORBPR	2	
109	41703027	SA5251001	垫圈	SPACER	1	
110	S05117	018064031	螺栓 M6×40	BOLT SOCKET M6×40	1	
111	N01021	021060106	螺母 M6	NUT 1 M6	1	
112	41702023	SA4847001	轴 U	SHAFT U	1	
113	S10019	012060636	螺钉 M6×6	SET SCREW SOCKET (CP)M6×6	1	

Z. 附件 / Accessories

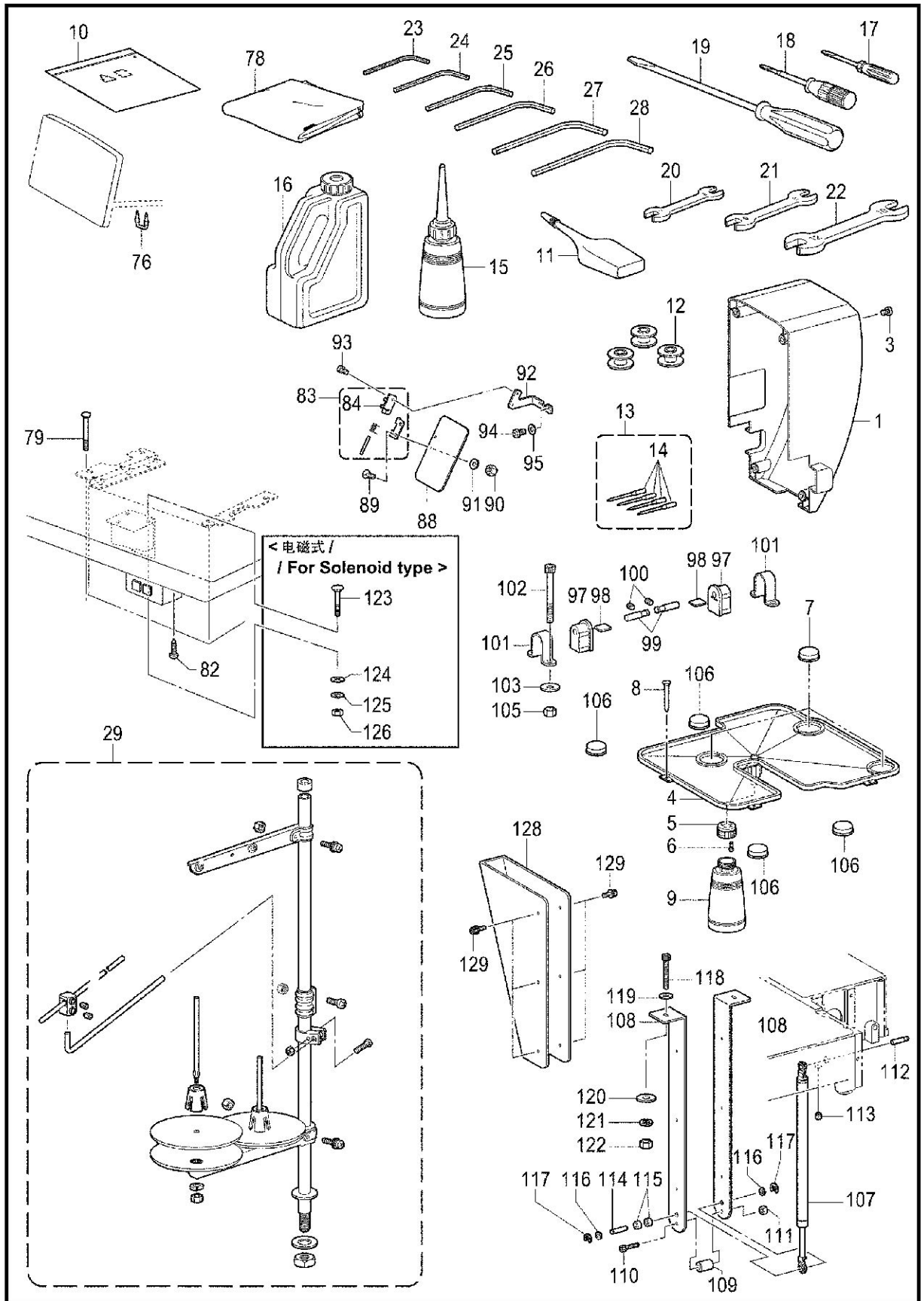

Z、附件/Accessories

序号 No.	公司件号 Part. No.	参考件号 Ref. No.	零部件名称	NAME OF PARTS	数量 Amt.	备注
114	41702024	S17974001	轴 D	SHAFT D	1	
115	41703028	S17975100	轴套 GS	SHAFT COLLAR GAS	2	
116	41728018	025080132	垫圈 S8	WASHER PLAIN S8	2	
117	H05031	048060342	挡圈 E6	RETAINING RING E6	2	
118	S05112	SA3387001	螺栓 M6×60	BOLT SOCKET M6×60	2	
119	W01003	025060236	平垫圈 M6	WASHER PLAIN M6	2	
120	41728030	213650001	垫圈 2.3×8.5×38	WASHER 2.3×8.5×38	2	
121	W02009	028060246	弹簧垫圈 2-6	WASHER SPRING 2-6	2	
122	N01021	021060106	螺母 M6	NUT 1 M6	2	
			<电磁式>	<For Solenoid type>		
123	S05112	119755001	螺栓 M6×60	BOLT M6×60	2	
124	W01003	025060236	平垫圈 M6	WASHER PLAIN M6	2	
125	W02009	028060246	弹簧垫圈 2-6	WASHER SPRING 2-6	2	
126	N01021	021060106	螺母 M6	NUT 1 M6	2	
128	41712114	SA6261001	支架盖	HOLDER ABSORBER COVER	1	
129	417S30033	S55479001	螺栓 (带垫圈) M4×8	BOLT SOCKET (S/P WASHER) M4×8	6	

Ga . 工模具一览表 / Gauge parts list

压脚 / Presser foot			
A / S42843-001 *	B / S42844-001	C / S42845-001	D / S42846-001
E / S42847-001	F / 157237-001	G / 158592-001	J / S42848-001
A-CUT / S40214-001	B-L / S49448-001	XA / S42849-101	H / SA4811-001 *

针孔板 / Needle hole plate		
2.4 C0.4 / SA3336-001 *	2.2 / SA5221-001 *	3.0 C1.5 / SA5222-001 *

印有*记号的为标准零部件
The * symbol is for Standard parts.