



Smooth Ride
www.srcasters.com



www.srcasters.com

Smooth Ride Casters, Inc.
2620 Loma Ave.
South El Monte, CA 91733
Tf. 800.772.1599

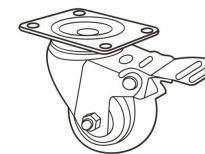

SR CASTERS
PRODUCT CATALOG

INTRODUCTION

Smooth Ride Casters (SRC), based in Southern California, is a one-stop-shop casters manufacturing company. From design to production to quality control to delivery, we make the entire process seamless.

SRC is a U.S.-based company with principle design and production platforms in China. This set-up allows for even the most radical and audacious casters to be manufactured. Furthermore, China-based manufacturing creates a cost-effectiveness that is unparalleled in the industry. Our quality control measures are as stringent as mandated by the internationally accepted standards. Our factory is ISO 9001 certified.

Our commitment to quality and performance, cost-effective and service, and attention to detail brings value to all. We welcome low volume OEM. Between SRC and our factory partners, we serve customers from all over the world.



Factory



Injection Workshop



Assembling Workshop



Braking Performance Testing Equipment



Obstacle Dynamic Testing Equipment for Linear Track



Non-obstacle Dynamic Testing Equipment For Cylindrical Track



Corrosion Testing Equipment



Abrasion Resistant Testing Equipment

































Temperature Testing Equipment



Fatigue Testing Equipment for Braking



Durometer Testing Equipment

Series		Plating	Bearing	Wheel Size	York	Brake	Wheel Material
UL	ULTRA LIGHT DUTY CASTER SERIES	Zinc Plated / Z	NO Bearing / 0	1"	Top Plate Rigid / PR	Side Lock Brake (Metal) / SLM	PP106 YUPA(One moulding Advanced Polyolefin)  PP116 YUPA(Twice moulding Advanced Polyolefin) 
L	LIGHT DUTY CASTER SERIES	Black Color Paint / B	Single Ball Bearing / 1	1.6"	Top Plate Swivel / PS	Wheel Lock Brake (Metal) / WLM	PP125/PP126 PP Polyolefin(flat tread)  PP135 PP H-tech Polyolefin(flat tread)  PP146 PP Polyolefin(round tread) 
M1/M2	MEDIUM DUTY CASTER SERIES	Yellow Zinc Plated / Y	Double Ball Bearing / 2	2"	Threaded Stem / TH	Total Lock Brake (Metal) / TLM	PU205/PU206 PU Super strong PU wheel(flat tread)  PU212/PU215 PU Hi-class PU wheel(flat tread)  PU216/PU217 PU Hi-class PU wheel(flat tread)  PU222/PU226 PU Polyurethane(flat tread)  PU235/PU236 PU Hi-tech Polyurethane (flat tread) 
MH	MEDIUM/HEAVY DUTY CASTER SERIES	Wrinkle Black Color Paint /WB	Four Ball Bearing / 4	2.5"	Hollow Rivet / H	Wheel Lock Brake (Plastic) / WLP	PU246 PU Upgrade PU(flat tread)  PU276 PU Hi-tech Polyurethane (round tread)  PU286 PU Polyurethane(round tread)  PU296 PU Hi-tech Polyurethane(round tread) 
H1/H2	HEAVY DUTY CASTER SERIES		Annular Bearing / A	3"	Grip Ring Stem / GR	Total Lock Brake (Plastic) / TLP	PU306/PU307 PU Iron/Urethane wheel (flat tread)  PU326 PU Aluminium/Urethane wheel(flat tread)  PU346 PU Iron/Urethane wheel(round tread) 
LP1/LP2/LP3	LOW PROFILE CASTER SERIES		Nylon Bushing Bearing / N	4"	Expandable Stem / EXP		PA400/PA402/PA406 PA Plastic Nylon(flat tread)  PA426 Nylon w/pattern(round tread) 
ESD	ELECTICAL STATIC DISCHARGE CASTER SERIES			5"	Round Stem / RS		HT1 482/HT2 486/HT3 486 PA Nylon(Hi-temp)  ER505 ER Elastic rubber(flat tread)  ER516 ER Super strong elastic rubber(flat tread)  ER526 ER Iron casing elastic rubber(flat tread)  ER537 ER Iron elastic rubber(flat tread)  TR552 HR hard rubber(flat tread) 
HT1/HT2/HT3	HIGH TEMP.RESISTANCE CASTER SERIES			6"			TPR612/TPR615 TPR wheel(flat tread)  TPR615B/TPR616 TPR wheel(flat tread)  TPR625/PR626 TPR wheel(flat tread) 
SA	SHOCK ABSORBING CASTER SERIES			8"			TPR633 TPR wheel (conductive)  PN726 ER Pneumatic rubber 
FM	FOAM CASTER SERIES			10"			
PN	PNEUMATIC CASTER SERIES			12"			
MED1/MED2/MED3/MED4	MEDICAL CASTER SERIES						
SF	SCAFFOLD CASTER SERIES						
TI	PLASTIC HAND TRUCK CASTER SERIES						
PF	DOUY/PLATFORM TRUCK						

INDEX

INTRODUCTION	P-01
INTRODUCTION OF PRODUCTION AND TESTING EQUIPMENTS	P-02
ARTICLE NO. INTRUCTION	P-03/04
INDEX	P-05/06
UL SERIES LIGHT DUTY CASTER ULTRA SERIES	P-07/08
L SERIES LIGHT DUTY DOUBLE BALL BEARING SERIES	P-09/10
MI/M2 SERIES MEDIUM DUTY SINGLE BALL BEARING SERIES	P-11/14
MH SERIES MEDIUM/HEAVY DUTY DOUBLE BALL BEARING SERIES	P-15/16
HI/H2 SERIES HEAVY DUTY DOUBLE BALL BEARING SERIES	P-17/20
LP/LP1/LP2 /LP3 SERIES LOW PROFILE NYLONY BUSHING (TWINS WHEEL)	P-21/24
HT1/HT2/HT3 SERIES HIGH TEMP.RESISTANCE NYLON SERIES	P-25/27
FM SERIES FOAM DOUBLE BALL BEARIN SERIES	P-28
SA SERIES SHOCK ABSORSIN DOUBLE BALL BEARING SERIES	P-29/30
PN SERIES PNEUMATIC DOUBLE BALL BEARING SERIES	P-31
MED1/MED2/MED3 SERIES MEDICAL NYLOIN BUSHING BEARING SERIES	P-32/34
MED4 SERIES MDICAL CASTER(TPR WHEEL)	P-35
ESD SERIES ELECTICAL STATIC DISCHARGE ANNULAR BEARING SERIES	P-36
SF SERIES SCAFFOLD CASTER : MEDIUM DUTY/HEAVY DUTY	P-37/38
DL SERIES DOLLY	P-39
PF SERIES PLATFORM TRUCK	P-40
T1 SERIES PLASTIC HAND TRUCK CASTER	P-41





UL LIGHT DUTY CASTER ULTRA SERIES

Wheels Dia 1"~4"

KG 8~65kg

Wheel Option 1"~4" | UL Series Capacity 8~65kg



PU222

- 1" /12kg
- 1.25" /16kg
- 1.5" /20kg
- 2" /30kg
- 2.5" /40kg
- 3" /50kg
- 4" /65kg



TRP612

- 1" /8kg
- 1.25" /10kg
- 1.5" /15kg
- 2" /20kg
- 2.5" /30kg
- 3" /35kg
- 4" /40kg



TRP615

- 1" /10kg
- 1.25" /15kg
- 1.5" /20kg
- 2" /25kg

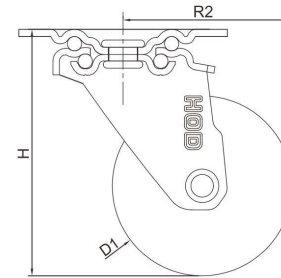

Spec. Demonstration



1"~4" Yoke Option Black



- Top Plate Swivel**
- 1" ULBO-1PS
 - 1.25" ULBO-125PS
 - 1.5" ULBO-15PS
 - 2" ULBO-2PS
 - 2.5" ULBO-25PS
 - 3" ULBO-3PS
 - 4" ULBO-4PS



- Swivel Side Lock (Metal)**
- 1" ULBO-1PSSLM
 - 1.25" ULBO-125PSSLM
 - 1.5" ULBO-15PSSLM
 - 2" ULBO-2PSSLM
 - 2.5" ULBO-25PSSLM
 - 3" ULBO-3PSSLM
 - 4" ULBO-4PSSLM



- Threaded Stem**
- 1" ULBO-1TH
 - 1.25" ULBO-125TH
 - 1.5" ULBO-15TH
 - 2" ULBO-2TH
 - 2.5" ULBO-25TH
 - 3" ULBO-3TH
 - 4" ULBO-4TH



- Threaded Side Lock (Metal)**
- 1" ULBO-1THSLM
 - 1.25" ULBO-125THSLM
 - 1.5" ULBO-15THSLM
 - 2" ULBO-2THSLM
 - 2.5" ULBO-25THSLM
 - 3" ULBO-3THSLM
 - 4" ULBO-4THSLM



- Top Plate Rigid**
- 1" ULBO-1PR
 - 1.25" ULBO-125PR
 - 1.5" ULBO-15PR
 - 2" ULBO-2PR
 - 2.5" ULBO-25PR
 - 3" ULBO-3PR
 - 4" ULBO-4PR

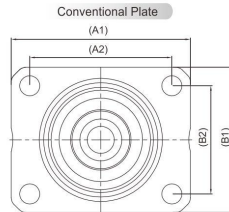

Wheel Dia (in)	Tread Width (mm)	Load Height (mm)	Swivel Radius (mm)	Plate Size (mm)	Plate Size (mm)	Hole Size (mm)	Thread Size (mm)
25/1"	13	37	28/31	38x30	29x21	4.2	M8x15
32/1.25"	14	44	32.5/35	38x30	29x21	4.2	M8x15
38/1.5"	17	52	37/40	46x38	36x28	5.2	M8x15
50/2"	22	68.5	47/52	58.5x47	46x35	6.5	M10x20
63/2.5"	22	81.5	56.5/61.5	70x52	54x36	8.5	M10x25
75/3"	22	95.5	64.5/69.5	70x52	54x36	8.5	M10x25
100/4"	25	122	83/88	80x58	63x40	8.5	M12x25



Yoke Finished Options

Brake Materials Options



ULBO-1PSSTLM-TPR612

Ultra Light Duty
Black Color Paint
NO bearing
Wheel Size
Top plate swivel
Side Lock Metal
Wheel Type

Sample Item Number

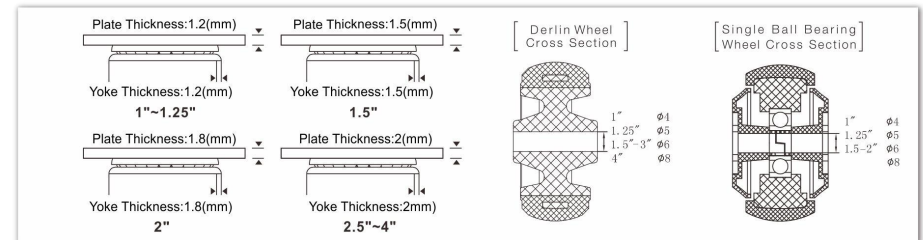



L SERIES LIGHT DUTY DOUBLE BALL BEARING SERIES

Wheel Option 2.5"~4" | L Series Capacity 55~100kg



PP116

- 2.5" / 75kg
- 3" / 85kg
- 4" / 100kg



PU236

- 2.5" / 70kg
- 3" / 80kg
- 4" / 95kg



PU286

- 2.5" / 65kg
- 3" / 70kg
- 4" / 90kg



TPR626

- 2.5" / 55kg
- 3" / 65kg
- 4" / 70kg

2.5"~4" Yoke Option Black/Zinc



Top Plate Swivel
2.5" LB2-25PS
3" LB2-3PS
4" LB2-3PS



Swivel Total Lock(Plastic)
2.5" LB2-25PSTLP
3" LB2-3PSTLP
4" LB2-4PSTLP



Threaded Stem
2.5" LB2-25TH
3" LB2-3TH
4" LB2-4TH



Threaded Total Lock
2.5" LB2-25HTLP
3" LB2-3HTLP
4" LB2-4HTLP



Hollow Rivet
2.5" LB2-25H
3" LB2-3H
4" LB2-4H



Hollow Rivet Total Lock(Plastic)
2.5" LB2-25HTLP
3" LB2-3HTLP
4" LB2-3HTLP



Grip Ring
2.5" LB2-25GR
3" LB2-3GR
4" LB2-3GR



Grip Ring Total Lock(Plastic)
2.5" LB2-25GRTP
3" LB2-3GRTP
4" LB2-3GRTP



Top Plate Rigid
2.5" LB2-25PR
3" LB2-3PR
4" LB2-3PR



Sample Item Number

LB 2-3 GRTLP-TPR626

Light Duty Black Color Paint | Double Bearing | Wheel Size | Grip Ring Fastening Type | Total Lock Brake (Plastic) | Wheel Type

Wheel Dia 2.5"~4"

Load Capacity 55~100kg

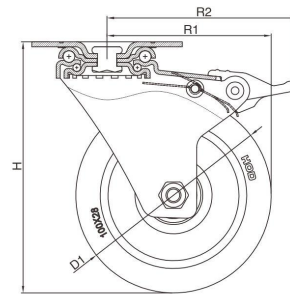

Spec.Demonstration



Wheel Dia (in)	Tread Width (mm)	Load Height (mm)	Swivel Radius (mm)	Plate Size (mm) (A1xB1)	Plate Size (mm) (A2xB2)	Hole Size (mm)	Thread Size (mm)	Hollow Size (mm)	Grip Ring Stem (mm)
63 / 2.5"	28	91.5	62.5 / 93	80 X 58	60.5x40	8.2	M12x25	∅10.2	11x38
75 / 3"	28	103	69.5 / 93	80 X 58	60.5x40	8.2	M12x25	∅10.2	11x38
100 / 4"	28	128.5	84 / 97	80 X 58	60.5x40	8.2	M12x25	∅10.2	11x38

Blue Zinc | Black Color Paint

Yoke Finished Options

Brake Materials Options

Metal Total Lock | Plastic Total Lock

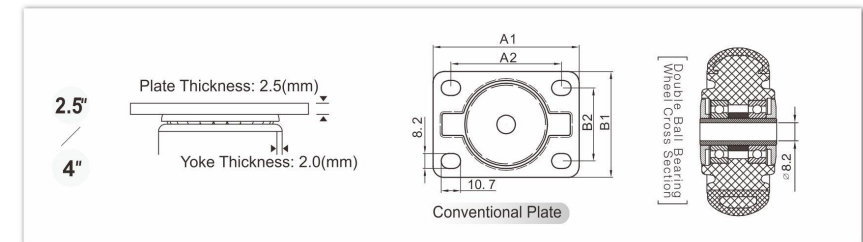



M1 MEDIUM DUTY SINGLE BALL BEARING SERIES

Wheel Dia 1.6"~5"

Load Capacity 30~160kg

Wheel Option 1.6"~5" | M1 Series Capacity 30~160Kg

PP125	PP135	PU205	PU215	PU235	PU246	ER505	TPR625
1.6" / 40kg 2" / 55kg 2.5" / 100kg 3" / 120kg 4" / 140kg 5" / 150kg	1.6" / 40kg 2" / 55kg 2.5" / 100kg 3" / 120kg 4" / 140kg 5" / 150kg	1.6" / 30kg 2" / 45kg 2.5" / 95kg 3" / 110kg 4" / 135kg 5" / 150kg	2.5" / 100kg 3" / 115kg 3" / 120kg 4" / 140kg 5" / 155kg	1.6" / 35kg 2" / 50kg 2.5" / 105kg 3" / 120kg 4" / 145kg 5" / 160kg	2.5" / 100kg 3" / 115kg 4" / 140kg 5" / 155kg	2.5" / 70kg 3" / 90kg 4" / 120kg 5" / 130kg	1.6" / 30kg 2" / 35kg 2.5" / 65kg 3" / 85kg 4" / 110kg 5" / 125kg

1.6"~5" Yoke Option Zinc/Black

Top Plate Swivel	Swivel Side Lock (Metal)	Swivel Total Lock (Metal)	Threaded Stem	Threaded Side Lock (Metal)	Threaded Total Lock (Metal)	Hollow Rivet
1.6" M1Z1-16PS 2" M1Z1-2PS 2.5" M1Z1-25PS 3" M1Z1-3PS 4" M1Z1-4PS 5" M1Z1-5PS	1.6" M1Z1-16PSSLM 2" M1Z1-2PSSLM 2.5" M1Z1-25PSSLM 3" M1Z1-3PSSLM 4" M1Z1-4PSSLM 5" M1Z1-5PSSLM	1.6" M1Z1-16PSTLM 2" M1Z1-2PSTLM 2.5" M1Z1-25PSTLM 3" M1Z1-3PSTLM 4" M1Z1-4PSTLM 5" M1Z1-5PSTLM	1.6" M1Z1-16TH 2" M1Z1-2TH 2.5" M1Z1-25TH 3" M1Z1-3TH 4" M1Z1-4TH 5" M1Z1-5TH	1.6" M1Z1-16THSLM 2" M1Z1-2THSLM 2.5" M1Z1-25THSLM 3" M1Z1-3THSLM 4" M1Z1-4THSLM 5" M1Z1-5THSLM	1.6" M1Z1-16HTLM 2" M1Z1-2HTLM 2.5" M1Z1-25HTLM 3" M1Z1-3HTLM 4" M1Z1-4HTLM 5" M1Z1-5HTLM	1.6" M1Z1-16H 2" M1Z1-2H 2.5" M1Z1-25H 3" M1Z1-3H 4" M1Z1-4H 5" M1Z1-5H
Hollow Rivet Side Lock (Metal)	Hollow Rivet Total Lock (Metal)	Top Plate Rigid	Type B Expandable Stem Total Lock (Plastic)	Type C Expandable Stem Total Lock (Plastic)	Type D Expandable Stem Total Lock (Plastic)	
1.6" M1Z1-16HSLM 2" M1Z1-2HSLM 2.5" M1Z1-25HSLM 3" M1Z1-3HSLM 4" M1Z1-4HSLM 5" M1Z1-5HSLM	1.6" M1Z1-16HTLM 2" M1Z1-2HTLM 2.5" M1Z1-25HTLM 3" M1Z1-3HTLM 4" M1Z1-4HTLM 5" M1Z1-5HTLM	1.6" M1Z1-16PR 2" M1Z1-2PR 2.5" M1Z1-25PR 3" M1Z1-3PR 4" M1Z1-4PR 5" M1Z1-5PR	2.5" M1Z1-25EXPTLP 3" M1Z1-3EXPTLP 4" M1Z1-4EXPTLP 5" M1Z1-5EXPTLP	2.5" M1Z1-25EXPTLP 3" M1Z1-3EXPTLP 4" M1Z1-4EXPTLP 5" M1Z1-5EXPTLP	2.5" M1Z1-25EXPTLP 3" M1Z1-3EXPTLP 4" M1Z1-4EXPTLP 5" M1Z1-5EXPTLP	



M1 Z 1-4 PS TLM-PU205

Medium Duty Zinc Plated Yoke Single Bearing Wheel Size Top Plate Swivel Total Lock Brake (Metal) Wheel Type

Sample Item Number

Spec Demonstration

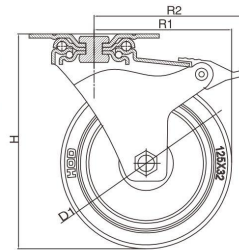

Conventional Plate

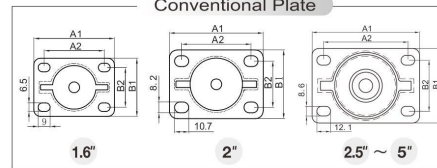

Wheel Dia (in)	Tread Width (mm)	Load Height (mm)	Swivel Radius (mm)	Plate Size (A1xB1)	Plate Size (A2xB2)	Hole Size (mm)	Thread Size (mm)	Hollow Size (mm)
40 / 1.6"	22	61.5	45 / 67	61 X 44	45.5x30	6.5	M8x20	/
50 / 2"	26	74.5	53 / 76	71 X 52	52.5x35	8.2	M10x25	/
63 / 2.5"	32	94	66.5 / 70 / 102	95x66.5	74.5x45	8.5	M12x25	∅12
75 / 3"	32	106	72.5 / 72.5 / 102	95x66.5	74.5x45	8.5	M12x25	∅12
100 / 4"	32	131	85 / 85 / 107	95x66.5	74.5x45	8.5	M12x25	∅12
125 / 5"	32	157	100.5 / 100.5 / 113	95x66.5	74.5x45	8.5	M12x25	∅12

Brake Options

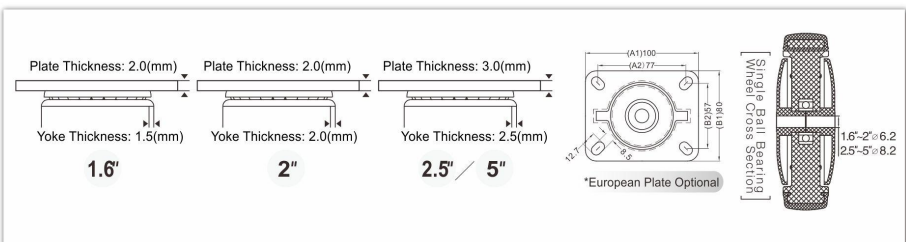



M2 SERIES MEDIUM DUTY DOUBLE BALL BEARING SERIES

Wheel Option 1.6"~5" | M2 Series Capacity 35~170Kg

PP106	PU206	PU226	PU236	PU286	PA406	TPR616
1.6" / 45kg 2" / 60kg 3" / 115kg 4" / 140kg 5" / 160kg	1.6" / 35kg 2" / 50kg 3" / 115kg 4" / 140kg 5" / 155kg	3" / 120kg 4" / 145kg 5" / 160kg	1.6" / 40kg 2" / 55kg 3" / 120kg 4" / 145kg 5" / 160kg	3" / 100kg 4" / 130kg 5" / 140kg	1.6" / 45kg 2" / 60kg 3" / 135kg 4" / 155kg 5" / 170kg	1.6" / 35kg 2" / 40kg 3" / 90kg 4" / 110kg 5" / 120kg

1.6"~5" Yoke Option Zinc/Black

Top Plate Swivel	Swivel Side Lock (Metal)	Swivel Total Lock (Metal)	Threaded Stem	Threaded Side Lock (Metal)	Threaded Total Lock (Metal)	Hollow Rivet
1.6" M222-16PS 2" M222-2PS 2.5" M222-25PS 3" M222-3PS 4" M222-4PS 5" M222-5PS	1.6" M222-16PSSLM 2" M222-2PSSLM 2.5" M222-25PSSLM 3" M222-3PSSLM 4" M222-4PSSLM 5" M222-5PSSLM	1.6" M222-16PSTLM 2" M222-2PSTLM 2.5" M222-25PSTLM 3" M222-3PSTLM 4" M222-4PSTLM 5" M222-5PSTLM	1.6" M222-16TH 2" M222-2TH 2.5" M222-25TH 3" M222-3TH 4" M222-4TH 5" M222-5TH	1.6" M222-16THSLM 2" M222-2THSLM 2.5" M222-25THSLM 3" M222-3THSLM 4" M222-4THSLM 5" M222-5THSLM	1.6" M222-16HTLM 2" M222-2HTLM 2.5" M222-25HTLM 3" M222-3HTLM 4" M222-4HTLM 5" M222-5HTLM	1.6" M222-16H 2" M222-2H 2.5" M222-25H 3" M222-3H 4" M222-4H 5" M222-5H

Hollow Rivet Side Lock (Metal)	Hollow Rivet Total Lock (Metal)	Top Plate Rigid
1.6" M222-16HSLM 2" M222-2HSLM 2.5" M222-25HSLM 3" M222-3HSLM 4" M222-4HSLM 5" M222-5HSLM	1.6" M222-16HTLM 2" M222-2HTLM 2.5" M222-25HTLM 3" M222-3HTLM 4" M222-4HTLM 5" M222-5HTLM	1.6" M222-16PR 2" M222-2PR 2.5" M222-25PR 3" M222-3PR 4" M222-4PR 5" M222-5PR

Conventional Plate

M2 B 2-4 TH TLP-PU226

Medium Duty Black Color Paint Double Bearing

Wheel Size Threaded Stem Total Lock Brake (Plastic) Wheel Type

Sample Item Number

Wheel Dia 1.6"~5"

Load Capacity 35~170kg

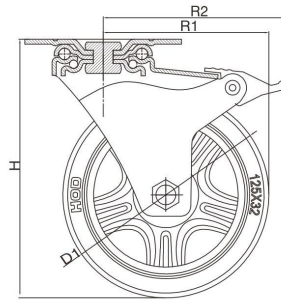

Spec. Demonstration



Wheel Dia (in)	Tread Width (mm)	Load Height (mm)	Swivel Radius (mm)	Plate Size (mm) (A1xB1)	Plate Size (mm) (A2xB2)	Hole Size (mm)	Thread Size (mm)	Hollow Size (mm)
40 / 1.6"	22	61.5	45 / 67	61 X 44	45.5 X 30	6.5	M8x20	/
50 / 2"	26	74.5	53 / 76	71 X 52	52.5 X 35	8.2	M10x25	/
75 / 3"	32	106	72.5 / 72.5 / 102	95 X 66.5	74.5 X 45	8.5	M12x25	∅12
100 / 4"	32	131	85 / 85 / 107	95 X 66.5	74.5 X 45	8.5	M12x25	∅12
125 / 5"	32	157	100.5 / 100.5 / 113	95 X 66.5	74.5 X 45	8.5	M12x25	∅12

Blue Zinc

Black Color Paint

Yoke Finished Options

Brake Options

Brake Options

Plate Thickness: 2.0(mm) Yoke Thickness: 1.5(mm) 1.6"	Plate Thickness: 2.0(mm) Yoke Thickness: 2.0(mm) 2"	Plate Thickness: 3.0(mm) Yoke Thickness: 2.5(mm) 3" / 5"
--	--	---

*European Plate Optional



MH SERIES MEDIUM/HEAVY DUTY DOUBLE BALL BEARING SERIES

Wheels Dia 3"~6"

Load Capacity 90~330kg

Wheel Option 3"~6" | MH Series Capacity 80~330Kg

PP126	PU226	PU236	PA406	ER516	ER526	TPR626
38mm	38mm	3"/4"=38mm 5"/6"=40mm	3"/4"=38mm 5"/6"=40mm	3"/4"=38mm 5"/6"=40mm	38mm	3"/4"=38mm 5"/6"=40mm
3" / 170kg	3" / 140kg	3" / 150kg	3" / 150kg	3" / 90kg	5" / 160kg	3" / 80kg
4" / 210kg	4" / 170kg	4" / 180kg	4" / 215kg	4" / 135kg	6" / 175kg	4" / 120kg
5" / 280kg	5" / 210kg	5" / 220kg	5" / 300kg	5" / 160kg		5" / 150kg
6" / 310kg	6" / 240kg	6" / 250kg	6" / 330kg	6" / 175kg		6" / 170kg

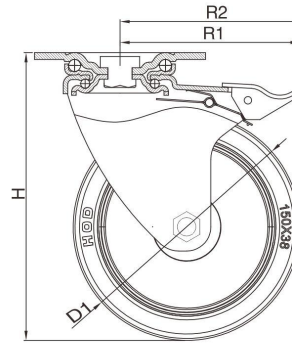

Spec. Demonstration



3"~6" Yoke Option Black/Zinc

Top Plate Swivel	Swivel Side Lock(Metal)	Swivel Total Lock(Metal)	Threaded Stem	Threaded Side Lock(Metal)
3" MHB2-3PS 4" MHB2-4PS 5" MHB2-5PS 6" MHB2-6PS	3" MHB2-3PSSLM 4" MHB2-4PSSLM 5" MHB2-5PSSLM 6" MHB2-6PSSLM	3" MHB2-3PSTLM 4" MHB2-4PSTLM 5" MHB2-5PSTLM 6" MHB2-6PSTLM	3" MHB2-3TH 4" MHB2-4TH 5" MHB2-5TH 6" MHB2-6TH	3" MHB2-3THSLM 4" MHB2-4THSLM 5" MHB2-5THSLM 6" MHB2-6THSLM
Threaded Total Lock(Metal)	Hollow Rivet	Hollow Rivet Side Lock(Metal)	Hollow Rivet Total Lock(Metal)	Top Plate Rigid
3" MHB2-3HTLM 4" MHB2-4HTLM 5" MHB2-5HTLM 6" MHB2-6HTLM	3" MHB2-3H 4" MHB2-4H 5" MHB2-5H 6" MHB2-6H	3" MHB2-3HSLM 4" MHB2-4HSLM 5" MHB2-5HSLM 6" MHB2-6HSLM	3" MHB2-3HTLM 4" MHB2-4HTLM 5" MHB2-5HTLM 6" MHB2-6HTLM	3" MHB2-3PR 4" MHB2-4PR 5" MHB2-5PR 6" MHB2-6PR

Wheel Dia (in)	Tread Width (mm)	Load Height (mm)	Swivel Radius (mm)	Plate Size (mm) (A1xB1)	Plate Size (mm) (A2xB2)	Hole Size (mm)	Thread Size (mm)	Hollow Size (mm)
75 / 3"	38	111	72.5/76.5/104.5	101.5x82.5	76.5x56.5	11	M16x35	∅16
100 / 4"	38	136	85 / 85 / 109	101.5x82.5	76.5x56.5	11	M16x35	∅16
125 / 5"	38~40	163	102.5/102.5/124.5	113x99	84.5x71.5	11	M20x40	∅16
150 / 6"	38~40	190	119/119/129.5	113x99	84.5x71.5	11	M20x40	∅16



Yoke Finished Options



Brake Options

MHB2-5PSTLM-PA406

Medium/Heavy Duty Black Color Double Bearing Wheel Size Top Plate Swivel Total Lock Brake (Metal) Wheel Type

Sample Item Number

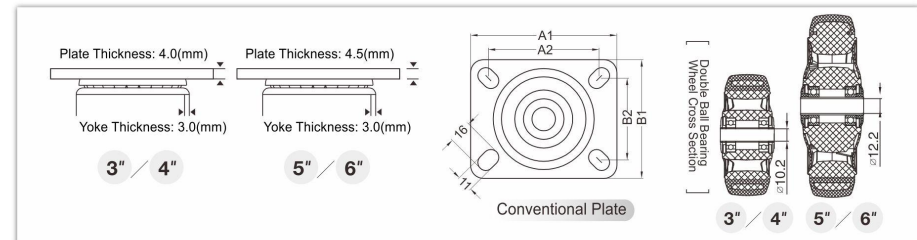



H1 HEAVY DUTY DOUBLE BALL BEARING SERIES

4"~8"

120~480kg

Wheel Option 4"~8" | H1 Series Capacity 120~480Kg



YUPA106

Tread Width 45(mm)
4" / 290kg
5" / 350kg
6" / 420kg
8" / 480kg



PU206

Tread Width 48(mm)
4" / 230kg
5" / 300kg
6" / 360kg
8" / 410kg



PU226

Tread Width 48(mm)
4" / 250kg
5" / 320kg
6" / 380kg
8" / 430kg



ER546

Tread Width 48(mm)
4" / 120kg
5" / 150kg
6" / 200kg
8" / 240kg

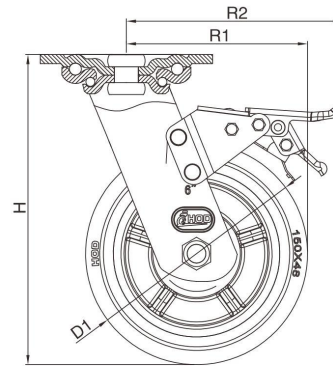

Spec.Demonstration

Wheel Dia (in)	Tread Width (mm)	Load Height (mm)	Swivel Radius (mm)	Plate Size (mm) (A1xB1)	Plate Size (mm) (A2xB2)	Hole Size (mm)
100 / 4"	45-48	144	82 / 92 / 125	115 x 100	84 x 71.5	11
125 / 5"	45-48	165	96.5 / 96.5 / 130	115 x 100	84 x 71.5	11
150 / 6"	45-48	191	114 / 114 / 140	115 x 100	84 x 71.5	11
200 / 8"	45-48	242	150 / 150 / 150	115 x 100	84 x 71.5	11

4"~8" Zinc Plated Yoke



Top Plate Swivel
4" H1Z2-4PS
5" H1Z2-5PS
6" H1Z2-6PS
8" H1Z2-8PS



Swivel Side Lock(Metal)
4" H1Z2-4PSSLM
5" H1Z2-5PSSLM
6" H1Z2-6PSSLM
8" H1Z2-8PSSLM



Swivel Total Lock(Metal)
4" H1Z2-4PSTLM
5" H1Z2-5PSTLM
6" H1Z2-6PSTLM
8" H1Z2-8PSTLM



Top Plate Rigid
4" H1Z2-4PR
5" H1Z2-5PR
6" H1Z2-6PR
8" H1Z2-8PR

Brake Options



Sample Item Number

H1 Z 2-6 P S T L M - P U 2 0 6

Heavy Duty Zinc Plated Double Wheel Top Plate Swivel Total Lock Brake (Metal) Wheel Type

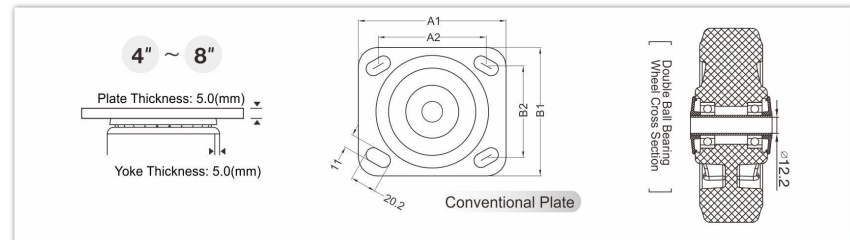



H2 HEAVY DUTY DOUBLE BALL BEARING SERIES

Wheel Dia 4"~8"

KG 130~505kg

Wheel Option 4"~8" | H2 Series Capacity 130~505Kg



YUPA146

Tread Width 50(mm)
4" / 280kg
5" / 340kg
6" / 420kg
8" / 450kg



PU246

Tread Width 48(mm)
4" / 280kg
5" / 350kg
6" / 400kg
8" / 450kg



PU276

Tread Width 49(mm)
4" / 240kg
5" / 295kg
6" / 355kg
8" / 385kg



PU296

Tread Width 45(mm)
4" / 270kg
5" / 330kg
6" / 380kg
8" / 420kg



PU306

Tread Width 50(mm)
4" / 280kg
5" / 350kg
6" / 400kg
8" / 450kg



PU346

Tread Width 48(mm)
4" / 290kg
5" / 385kg
6" / 440kg
8" / 505kg



PA426

Tread Width 45(mm)
4" / 300kg
5" / 360kg
6" / 430kg
8" / 480kg



ER516

Tread Width 48(mm)
4" / 200kg
5" / 250kg
6" / 340kg
8" / 430kg



TPR626

Tread Width 50(mm)
4" / 130kg
5" / 160kg
6" / 210kg
8" / 250kg

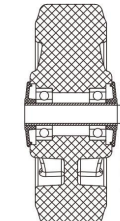

Double Ball Bearing Wheel Cross Section

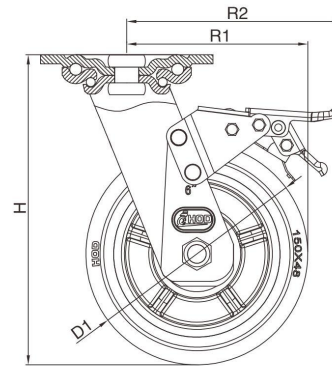

Spec. Demonstration



Wheel Dia (in)	Tread Width (mm)	Load Height (mm)	Swivel Radius (mm)	Plate Size (mm) (A1xB1)	Plate Size (mm) (A2xB2)	Hole Size (mm)
100 / 4"	45~50	144	81 / 91 / 129	118x103	84x71.5	11
125 / 5"	45~50	165	96 / 96 / 129	118x103	84x71.5	11
150 / 6"	45~50	191	115 / 115 / 141	118x103	84x71.5	11
200 / 8"	45~50	242	150 / 150 / 150	118x103	84x71.5	11

4"~8" Yoke Option Zinc/black Color Paint



Top Plate Swivel
4" H2Z2-4PS
5" H1Z2-6PS
6" H1Z2-6PS
8" H1Z2-8PS



Swivel Side Lock (Metal)
4" H2Z2-4PSSLM
5" H2Z2-5PSSLM
6" H2Z2-6PSSLM
8" H2Z2-8PSSLM



Swivel Lock (Metal)
4" H2Z2-4PSTLM
5" H2Z2-5PSTLM
6" H2Z2-6PSTLM
8" H2Z2-8PSTLM



Top Plate Rigid
4" H2Z2-4PR
5" H2Z2-5PR
6" H2Z2-6PR
8" H2Z2-8PR

Yoke Finished Options



Brake Options

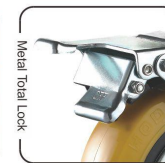

4" ~ 8"
Plate Thickness: 6.0(mm)
Yoke Thickness: 6.0(mm)

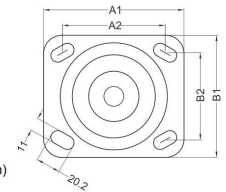

Sample Item Number

H2 Z 2-6 PSTLM-PU346

Medium/Heavy Duty | Zinc Plated Yoke | Double Bearing | Wheel Size | Top Plate Swivel | Total Lock Brake (Metal) | Wheel Type



LP LOW PROFILE NYLON
SERIES BUSHING (TWINS WHEEL)



1.6"~3"



130~250kg

LP1 LOW PROFILE DOUBLE
SERIES BALL BEARING



2.5"/3"



200 / 280kg

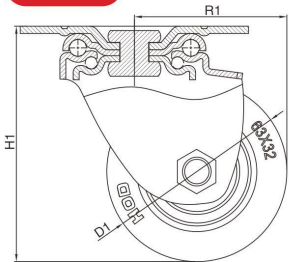

Spec.Demonstration

1.6" ~ 3"

Plate Thickness: 3.0(mm)

Yoke Thickness: 2.5(mm)

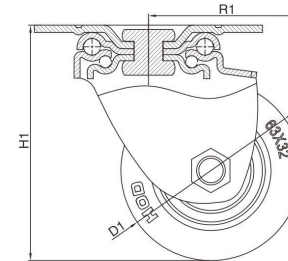

Spec.Demonstration

2.5" / 3"

Plate Thickness: 3.0(mm)

Yoke Thickness: 2.5(mm)



Wheel Option 1.6"~3"

1.6"~3" Black Color Paint Yoke



PA402

- 1.6" / 130kg
- 2" / 150kg
- 2.5" / 200kg
- 3" / 250kg

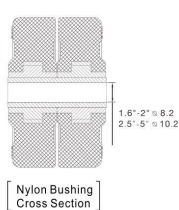

[Nylon Bushing Cross Section]

1.6"-2" ≈ 8.2
2.5"-5" ≈ 10.2



Top Plate Swivel
1.6" LPBN-16PS
2" LPBN-2PS
2.5" LPBN-25PS
3" LPBN-3PS



Hollow Rivet
1.6" LPBN-16H
2" LPBN-2H
2.5" LPBN-25H
3" LPBN-3H

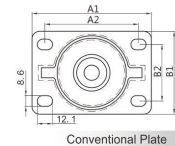

Conventional Plate



Threaded Stem
1.6" LPBN-16TH
2" LPBN-2TH
2.5" LPBN-25TH
3" LPBN-3TH

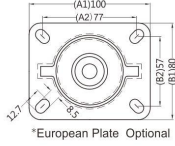

*European Plate Optional



Top Plate Rigid
1.6" LPBN-16PR
2" LPBN-2PR
2.5" LPBN-25PR
3" LPBN-3PR

Wheel Dia (in)	Tread Width (mm)	Load Height (mm)	Swivel Radius (mm)	Plate Size (A1xB1)	Plate Size (A2xB2)	Hole Size (mm)	Thread Size (mm)	Hollow Size (mm)
40/1.6"	22	62	44	95x66.5	74.5x45	8.5	M12x25	∅12
50/2"	22	72	49	95x66.5	74.5x45	8.5	M12x25	∅12
63/2.5"	22	85	56.5	95x66.5	74.5x45	8.5	M12x25	∅12
75/3"	22	98	63.5	95x66.5	74.5x45	8.5	M12x25	∅12

Wheel Option 2.5"~3"

2.5"/3" Black Color Paint Yoke



PP106

- 2.5" / 200kg
- 3" / 250kg



PP126

- 2.5" / 220kg
- 3" / 280kg

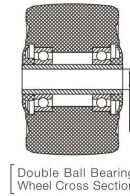

[Double Ball Bearing Wheel Cross Section]



Top Plate Swivel
2.5" LP1B2-25PS
3" LP1B2-3PS



Top Plate Rigid
2.5" LP1B2-25PR
3" LP1B2-3PR

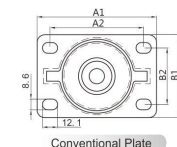

Conventional Plate

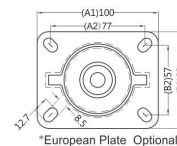

*European Plate Optional

Wheel Dia (in)	Tread Width (mm)	Load Height (mm)	Swivel Radius (mm)	Plate Size (A1xB1)	Plate Size (A2xB2)	Hole Size (mm)
63 / 2.5"	45	85	57	95x66.5	74.5x45	8.5
75 / 3"	45	98	64	95x66.5	74.5x45	8.5



LPBN-2TH-PA402

- Low Profile
- Black Color Paint
- Nylon Bushing
- Wheel Size
- Threaded
- Wheel Type

Sample Item Number



LP1B2-3PS-PP106

- Low Profile
- Black Color Paint
- Double Bearing
- Wheel Size
- Top Plate Swivel
- Wheel Type

Sample Item Number



LP2 LOW PROFILE DOUBLE BALL BEARING SERIES



2.5" / 3"



400 / 500kg

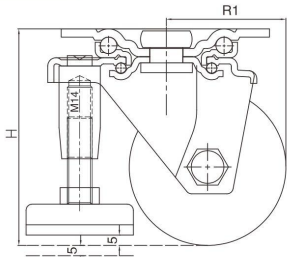

Spec. Demonstration



2.5" / 3"

Plate Thickness: 5.0(mm)

Yoke Thickness: 4.0(mm)

LP3 LOW PROFILE FOUR BALL BEARING SERIES



2.5" / 3"



600 / 700kg

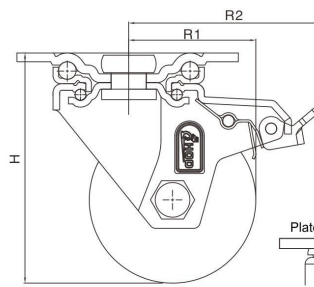

Spec. Demonstration



2.5" / 3"

Plate Thickness: 5.0(mm)

Yoke Thickness: 4.0(mm)

Wheel Option 2.5"~3"

2.5"/3" Black Color Paint Yoke

PA406
2.5" / 400kg
3" / 500kg

[Double Ball Bearing Wheel Cross Section]

Top Plate Swivel
2.5" LP2B2-25PS
3" LP2B2-3PS

Top Plate Swivel (With Lever)
2.5" LP2B2-25PSL
3" LP2B2-3PSL

Swivel Wheel Lock (Metal)
2.5" LP2B2-25PSTLM
3" LP2B2-3PSTLM

Top Plate Rigid
2.5" LP2B2-25PR
3" LP2B2-3PR

Top Plate Rigid (With Lever)
2.5" LP2B2-25PRL
3" LP2B2-3PRL

Conventional Plate

American Plate Optional

Wheel Option 2.5"~3"

2.5"/3" Black Color Paint Yoke

PA400
2.5" / 600kg
3" / 700kg

[Four Ball Bearing Wheel Cross Section]

Top Plate Swivel
2.5" LP3B4-25PS
3" LP3B4-3PS

Swivel Total Lock (Metal)
2.5" LP3B4-25PSWLM
3" LP3B4-3PSWLM

Top Plate Rigid
2.5" LP3B4-25PR
3" LP3B4-3PR

Conventional Plate

American Plate Optional

Wheel Dia (in)	Tread Width (mm)	Load Height (mm)	Swivel Radius (mm)	Plate Size (mm) (A1xB1)	Plate Size (mm) (A2xB2)	Hole Size (mm)
63 / 2.5"	50	96	58 / 98	101.5x82.5	76.5x56.5	11
75 / 3"	50	108	68 / 108	101.5x82.5	76.5x56.5	11

Wheel Dia (in)	Tread Width (mm)	Load Height (mm)	Swivel Radius (mm)	Plate Size (mm) (A1xB1)	Plate Size (mm) (A2xB2)	Hole Size (mm)
63 / 2.5"	50	96	58 / 98	101.5x82.5	76.5x56.5	11
75 / 3"	50	108	68 / 108	101.5x82.5	76.5x56.5	11



LP2 B 2-3 PRL-PA406

Sample Item Number

- Low Profile
- Black Color Double Paint
- Double Bearing
- Wheel Size
- Top Plate Rigid (With Lever)
- Wheel Type



LP3 B 4-3 PSWLM-PA400

Sample Item Number

- Low Profile
- Black Color Paint
- Four Bearing
- Wheel Size
- Top Plate Swivel
- Wheel Lock Brake (Metal)
- Wheel Type



HT1/HT2 HIGH TEMP.RESISTANCE NYLON SERIES

3"~5"

100~150kg

Wheel Option 3"~5" | HT1/HT2 Series Capacity 100~150Kg

HT1 SERIES
 200°C/392°F
 Maximum Temperature

HT1 482

3" / 100kg
 4" / 115kg
 5" / 150kg

Nylon Bushing
 [Cross Section]

HT2 SERIES
 260°C/500°F
 Maximum Temperature

HT2 486

3" / 100kg
 4" / 115kg
 5" / 150kg

Double Ball Bearing
 [Wheel Cross Section]

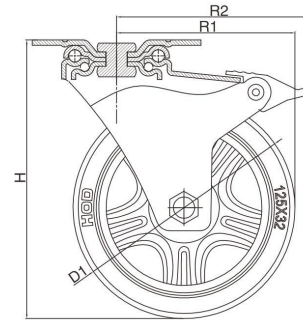

Spec.Demonstration



3"~5" Black Color Paint Yoke

Top Plate Swivel
 3" HT1BN-3PS
 4" HT1BN-4PS
 5" HT1BN-5PS

Swivel Side Lock (Metal)
 3" HT1BN-3PSSLM
 4" HT1BN-4PSSLM
 5" HT1BN-5PSSLM

Swivel Total Lock (Metal)
 3" HT1BN-3PSTLM
 4" HT1BN-4PSTLM
 5" HT1BN-5PSTLM

Threaded Stem
 3" HT1BN-3TH
 4" HT1BN-4TH
 5" HT1BN-5TH

Threaded Side Lock (Metal)
 3" HT1BN-3THSLM
 4" HT1BN-4THSLM
 5" HT1BN-5THSLM

Threaded Total Lock (Metal)
 3" HT1BN-3THTLM
 4" HT1BN-4THTLM
 5" HT1BN-5THTLM

Hollow Rivet
 3" HT1BN-3H
 4" HT1BN-4H
 5" HT1BN-5H

Hollow Rivet Side Lock (Metal)
 3" HT1BN-3HSLM
 4" HT1BN-4HSLM
 5" HT1BN-5HSLM

Hollow Rivet Total Lock (Metal)
 3" HT1BN-3HTLM
 4" HT1BN-4HTLM
 5" HT1BN-5HTLM

Top Plate Rigid
 3" HT1BN-3PR
 4" HT1BN-4PR
 5" HT1BN-5PR

Plate Thickness: 3.0(mm)
 Yoke Thickness: 2.5(mm)
 3" ~ 5"

Wheel Dia (in)	Tread Width (mm)	Load Height (mm)	Swivel Radius (mm)	Plate Size (mm) (A1xB1)	Plate Size (mm) (A2xB2)	Hole Size (mm)	Thread Size (mm)	Hollow Size (mm)
75 / 3"	32	106	72.5 / 72.5 / 102	95x66.5	74.5x45	8.5	M12x25	∅12
100 / 4"	32	131	85 / 85 / 107	95x66.5	74.5x45	8.5	M12x25	∅12
125 / 5"	32	157	100.5 / 100.5 / 113	95x66.5	74.5x45	8.5	M12x25	∅12

Brake Options

Metal Side Lock

Metal Total Lock

Conventional Plate

*European Plate

Optional

*Variety of threaded stem and grip ring stem are optional



HT2B 2-4 HTLM-HT2486

Sample Item Number

High temp Resistance Black color Paint Double ball Bearing Wheel Size Hollow Swivel Total Lock Brake (Metal) Wheel Type

Features:

The product has high temperature, wear resistance, weight resistance, impact resistance and other functions, unique formula and nylon material for injection molding, professional application in industries with special requirements for high temperature.

Application: It is especially suitable for use in food industry, oven, and other equipment.

Note: It is recommended that this series of products adopt black color paint finish and metal brake pedal, which is more resistant to high temperature.



HT3 HIGH TEMP. RESISTANCE NYLON SERIES

5" / 6" **KG** 370 / 450kg

FM FOAM DOUBLE BALL BEARING SERIES

6" ~ 10" **KG** 160 ~ 260kg

Wheel Option 5"/6"

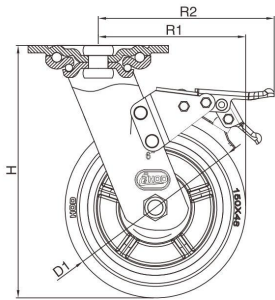

Spec. Demonstration

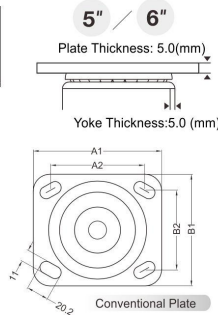

5" / 6"

Plate Thickness: 5.0 (mm)

Yoke Thickness: 5.0 (mm)

Conventional Plate



HT3 SERIES
260°C / 500°F
Maximum Temperature

5"/6" Black Color Paint Yoke



HT3 486

5" / 370kg

6" / 450kg

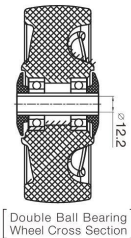

Double Ball Bearing Wheel Cross Section



Top Plate Swivel

5" HT3B2-5PS
6" HT3B2-6PS

Swivel Side Lock (Metal)

5" HT3B2-5HSLM
6" HT3B2-6HSLM

Swivel Total Lock (Metal)

5" HT3B2-5HTLM
6" HT3B2-6HTLM

Top Plate Rigid

5" HT3B2-5PR
6" HT3B2-6PR

Wheel Dia (in)	Tread Width (mm)	Load Height (mm)	Swivel Radius (mm)	Plate Size (mm) (A1xB1)	Plate Size (mm) (A2xB2)	Hole Size (mm)
125 / 5"	48	165	96.5/96.5/130	115 X 100	84x71.5	11
150 / 6"	48	191	114/114/140	115 X 100	84x71.5	11

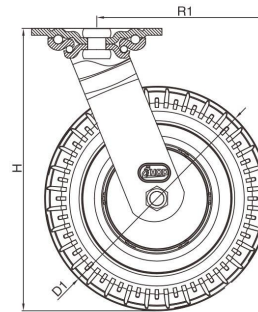

Spec. Demonstration



6" ~ 10"

Plate Thickness: 5.0 (mm)

Yoke Thickness: 5.0 (mm)

Conventional Plate



Wheel Option 6"~10"

6"~10" Olivaceous Zinc plated Yoke



FM716

6" / 160kg

8" / 210kg

10" / 260kg



Double Ball Bearing Wheel Cross Section



Top Plate Swivel

6" FMY2-6PS
8" FMY2-8PS
10" FMY2-10PS

Swivel Wheel Lock (Metal)

6" FMY2-6PSWLM
8" FMY2-8PSWLM
10" FMY2-10PSWLM

Top Plate Rigid

6" FMY2-6PR
8" FMY2-8PR
10" FMY2-10PR

Wheel Dia (in)	Tread Width (mm)	Load Height (mm)	Swivel Radius (mm)	Plate Size (mm) (A1xB1)	Plate Size (mm) (A2xB2)	Hole Size (mm)
150 / 6"	57	190	116 / 163	115 x 100	84x71.5	11
200 / 8"	64	250	153 / 189	115 x 100	84x71.5	11
250 / 10"	70	295	186 / 202	115 x 100	84x71.5	11



HT3 B 2-5 PS - HT3486

Sample Item Number

High temp Resistance

Black color Paint

Double ball Bearings

Wheel Size

Top Plate Swivel

Wheel Type



FM Y 2-6 PSWLM-F716

Sample Item Number

Foam Series

Olivaceous Zinc plated Yoke

Double Bearing

Wheel Size

Top Plate Swivel

Swivel Wheel Lock (Metal)

Wheel Type



SA
SERIES

SHOCK ABSORBIN DOUBLE BALL BEARING SERIES

Wheel Dia **5"~8"**

KG **200~400kg**

Wheel Option **5"~8"** | SA Series Capacity **200~400Kg**



AI.PU326



5" / 300kg

6" / 350kg

8" / 400kg



PU346



5" / 280kg

6" / 320kg

8" / 380kg



ER516



5" / 200kg

6" / 250kg

8" / 350kg

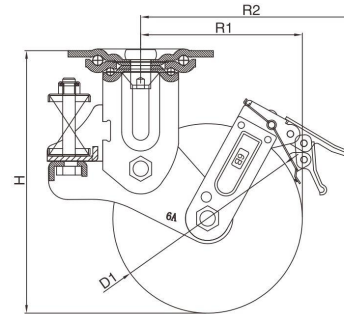

Spec.Demonstration

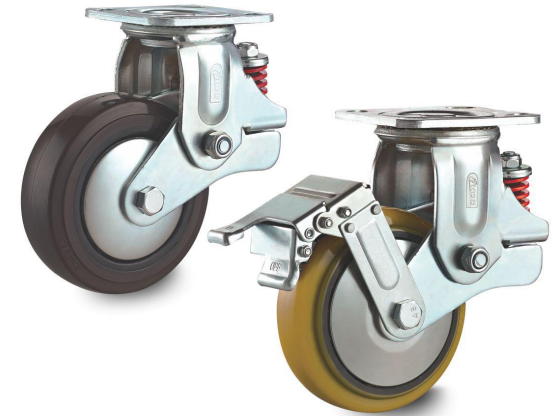

5"~8" Zinc Plated Yoke



Top Plate Swivel

5" SAZ2-5PS
6" SAZ2-6PS
8" SAZ2-8PS



Swivel Wheel Lock(Metal)

5" SAZ2-5PSWLM
6" SAZ2-6PSWLM
8" SAZ2-6PSWLM



Top Plate Rigid

5" SAZ2-5PR
6" SAZ2-6PR
8" SAZ2-8PR

Brake Detailed View

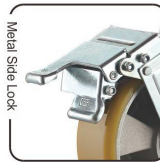

Metal Side Lock

Wheel Dia (in)	Tread Width (mm)	Load Height (mm)	Swivel Radius (mm)	Plate Size (mm) (A1xB1)	Plate Size (mm) (A2xB2)	Hole Size (mm)
125 / 5"	48	186	112 / 162	118x103	84x71.5	11
150 / 6"	48	210	128 / 171	118x103	84x71.5	11
200 / 8"	48	245	155 / 195	118x103	84x71.5	11

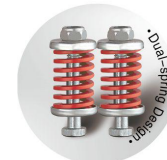

Application

- Reduce load capacity by 25% if caster is continually moving for 45 minutes.
- Reduce load capacity by 20% if caster is moving at the speed of 6kmph-10kmph(3.7 mph-6.2 mph).
- Reduce load capacity by 30% if caster is moving at the speed of 10kmph-13 kmph(6.2 mph - 8.08mph).
- The load capacities which are listed on this catalog are static load capacity.

For best performance use load capacity between 120 to 400 kg.



SA Z 2-6 PSWLM-ALPU326

Heavy Duty Zinc Plated Double Bearing Wheel Size Top Plate Swivel Swivel Wheel Lock (Metal) Wheel Type

Sample Item Number

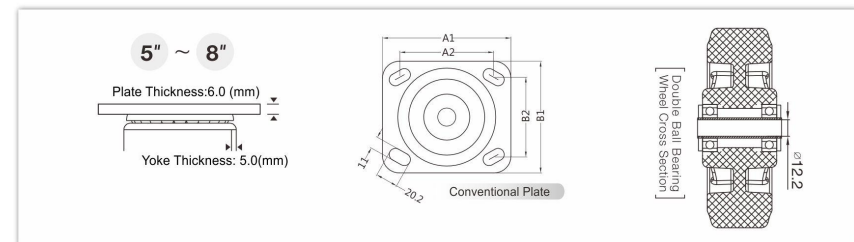



PN PNEUMATIC DOUBLE BALL BEARING SERIES



8" / 10"



160 / 220kg

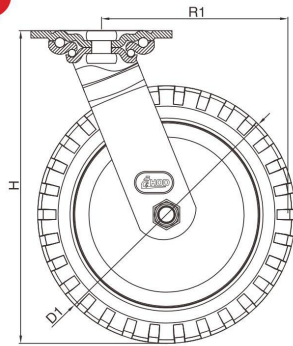

Spec.Demonstration



MED1 MEDICAL DOUBLE BALL BEARING SERIES



2.5"~4"



55~100kg

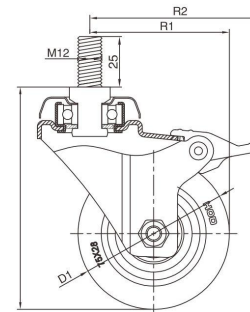

Spec.Demonstration

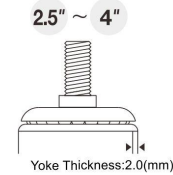

Wheel Option 8"/10"

8"/10" Olivaceous Zinc plated Yoke



PN726

8" / 160kg
10" / 220kg

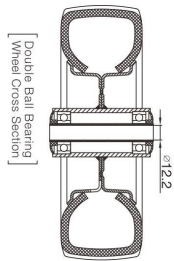

Top Plate Swivel
8" PNY2-8PS
10" PNY2-10PS



Top Plate Rigid
8" PNY2-8PR
10" PNY2-10PR

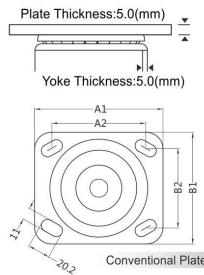

Conventional Plate

Wheel Dia (in)	Tread Width (mm)	Load Height (mm)	Swivel Radius (mm)	Plate Size (mm) (A1xB1)	Plate Size (mm) (A2xB2)	Hole Size (mm)
200 / 8"	64	258	156	115 x 100	84x71.5	11
250 / 10"	88	308	195	115 x 100	84x71.5	11

Wheel Option 2.5"~4"

2.5"~4" Zinc Plated Yoke



PU276

2.5" / 70kg
3" / 85kg
4" / 100kg



TPR626

2.5" / 55kg
3" / 65kg
4" / 70kg

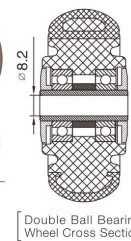

Double Ball Bearing Wheel Cross Section



Threaded Stem
2.5" MED1Z2-25TH
3" MED1Z2-3TH
4" MED1Z2-4TH



Threaded Total Lock (Plastic)
2.5" MED1Z2-25HTLP
3" MED1Z2-3HTLP
4" MED1Z2-4HTLP



Grip Ring
2.5" MED1Z2-25GR
3" MED1Z2-3GR
4" MED1Z2-4GR



Grip Ring Total Lock (Plastic)
2.5" MED1Z2-25GRTLTP
3" MED1Z2-3GRTLTP
4" MED1Z2-4GRTLTP

Wheel Dia (in)	Tread Width (mm)	Load Height (mm)	Swivel Radius (mm)	Thread Size (mm)	Grip Ring Stem 4#R*3 (mm)
63 / 2.5"	28	97	62.5 / 93	M12x25	∅11x38
75 / 3"	28	112	69.5 / 93	M12x25	∅11x38
100 / 4"	28	137	84 / 97	M12x25	∅11x38



PN Y 2-10 PS - PN726

Pneumatic series Olivaceous Zinc Plated Yoke Double Bearings Wheel Size Top Plate Swivel Wheel Type

Sample Item Number



MED1Z 2-3 GRTLTP - PU276

Medical series Zinc Plated Yoke Double Bearing Wheel Size Grip Ring Stem Total Lock Brake (Plastic) Wheel Type

Sample Item Number



MED2 MEDICAL NYLON BUSHING BEARING SERIES

Wheels Dia 3" Load Capacity 50 kg

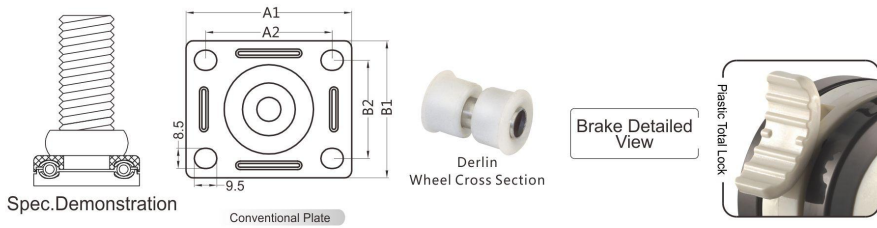

Wheel Dia (in)	Tread Width (mm)	Load Height (mm)	Swivel Radius (mm)	Plate Size (mm) (A1xB1)	Plate Size (mm) (A2xB2)	Hole Size (mm)	Thread Size (mm)	Hollow Size (mm)
75/3"	60	90/97	60/73	70x58	53.5x41.5	8.5	M12x25	∅11x38



MED2Z N-3 PS TLP-PU212

Sample Item Number

Medical series Zinc Plated Yoke Nylon Bushing Bearing Wheel Size Top Plate Swivel Total Lock Brake (Plastic) Wheel Type

MED3 MEDICAL DOUBLE BALL BEARING SERIES

Wheels Dia 2.5" Load Capacity 50 kg



Wheel Dia (in)	Tread Width (mm)	Load Height (mm)	Swivel Radius (mm)	Plate Size (mm) (A1xB1)	Plate Size (mm) (A2xB2)	Hole Size (mm)	Thread Size (mm)	Grip Ring Stem (mm)
63/2.5"	50	80/73	49/62	71x52	52.5x35	8.2	M10x15	∅11x38

MED3 MEDICAL NYLON BUSHING BEARING SERIES

Wheels Dia 4" Load Capacity 70 kg



Wheel Dia (in)	Tread Width (mm)	Load Height (mm)	Swivel Radius (mm)	Plate Size (mm) (A1xB1)	Plate Size (mm) (A2xB2)	Hole Size (mm)	Thread Size (mm)	Grip Ring Stem (mm)
100/4"	65	130/122	80/100	88x73	65x52.5	8.5	M12x25	∅11x38



MED3Z N-4 PS TLP-PU212

Sample Item Number

Medical series Zinc Plated Yoke Nylon Bushing Bearing Wheel Size Top Plate Swivel Total Lock Brake (Plastic) Wheel Type



MED4 MEDICAL CASTER (TPR WHEEL)



3"/4"



70/90kg

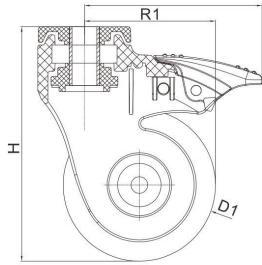

Beating Plate Spec. Demonstration

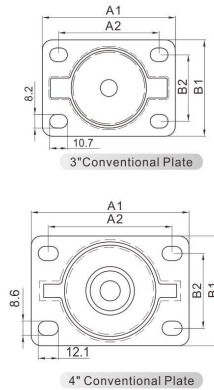

4" Conventional Plate

Wheel Option 3"/4"



- Top Plate Swivel**
3" MED4P1-3PS
4" MED4P1-4PS
- Swivel Total Lock (Plastic)**
3" MED4P1-3PSSLM
4" MED4P1-4PSSLM
- Threaded Stem**
3" MED4P1-3TH
4" MED4P1-4TH
- Threaded Total Lock (Plastic)**
3" MED4P1-3THTLPL
4" MED4P1-4THTLPL
- Hollow Rivet**
3" MED4P1-3H
4" MED4P1-4H
- Hollow Rivet Total Lock (Plastic)**
3" MED4P1-3HPR
4" MED4P1-4HPR

Single Ball Bearing
Wheel Cross Section

Wheel Dia (in)	Tread Width (mm)	Load Height (mm)	Swivel Radius (mm)	Plate Size (mm) (A1xB1)	Plate Size (mm) (A2xB2)	Hole Size (mm)	Thread Size (mm)	Hollow Size (mm)
75/3"	28	115.5	74.5/87.5	80x58	60.5x40	8.2	M12x25	∅12.2
100/4"	28	145	92/108.5	95x66.5	74.5x45	8.6	M12x25	∅12.2

ESD ELECTRICAL STATIC DISCHARGE ANNULAR BEARING SERIES



3"~5"



85~115kg

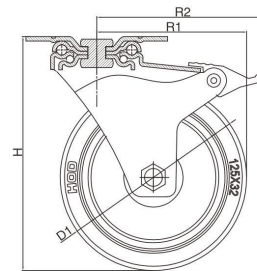

Spec. Demonstration

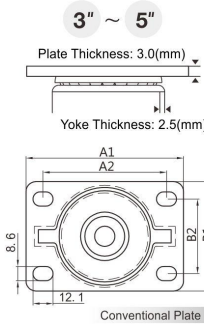

Conventional Plate



Conductivity Coefficient $10^3 \sim 10^5$

Wheel Option 3"~5"

3"~5" Zinc Plated Yoke

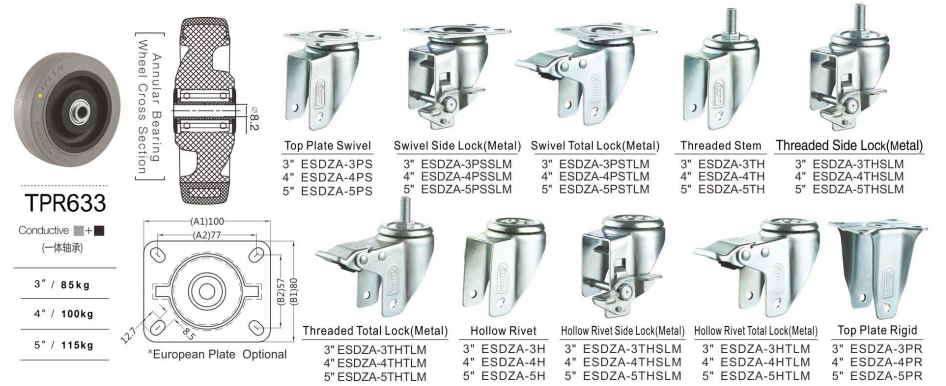

TPR633
Conductive (一体轴承)

3" / 85kg
4" / 100kg
5" / 115kg

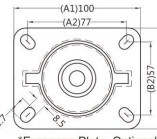

*European Plate Optional

Wheel Dia (in)	Tread Width (mm)	Load Height (mm)	Swivel Radius (mm)	Plate Size (mm) (A1xB1)	Plate Size (mm) (A2xB2)	Hole Size (mm)	Thread Size (mm)	Hollow Size (mm)
75/3"	32	106	72.5/72.5/102	95x66.5	74.5x45	8.5	M12x25	12
100/4"	32	131	85/85/107	95x66.5	74.5x45	8.5	M12x25	12
125/5"	32	157	100.5/100.5/113	95x66.5	74.5x45	8.5	M12x25	12



MED4 D 1-3 TH-TPR615B

Medical Caster Plastic Single ball Bearing Wheel Size Thread Stem Wheel Type

Sample Item Number



ESDZA-4 PSTLM-TPR633

Electrical Static Discharge Series Zinc Plated Annular Bearing Wheel Size Top Plate Swivel Total Lock Brake (Metal) Wheel Type

Sample Item Number



SF SCAFFOLD CASTER : MEDIUM DUTY
SERIES



5"



160kg

SF SCAFFOLD CASTER : HEAVY DUTY
SERIES



6"/8"



380/430kg



HR552



5" / 160kg



PU217



6" / 380kg
8" / 430kg

PU307



6" / 380kg
8" / 430kg

ER537



6" / 180kg
8" / 250kg

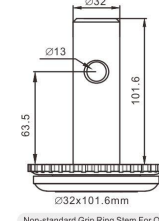
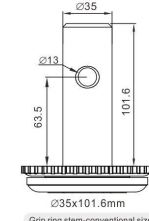
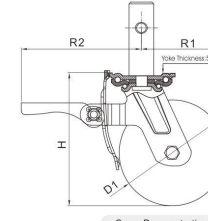
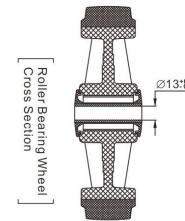
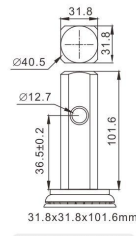
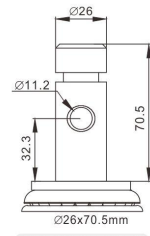
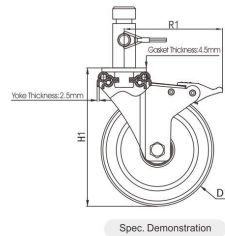
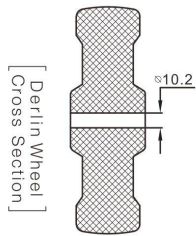

Wheel Dia (in)	Tread Width (mm)	Load Height (mm)	Brake Swivel Radius (mm)	Square stem (mm)	Grip Ring Stem (mm)
125/5"	35	158.5	113	31.8x31.8x101.6	∅26x70.5

Wheel Dia (in)	Tread Width (mm)	Load Height (mm)	Brake Swivel Radius (mm)	Grip Ring Stem (mm)
150/6"	50	188.5	119	∅35x101.6
200/8"	50	236	154	∅35x101.6



SF ZO-5 RSTLM-HR552

Scaffold Caster Zinc Plated Yoke Nylon Bushing Bearing Wheel Size Grip ring stem total lock(Metal) Wheel Type

Sample Item Number



SF ZR-6 RSTLM-PU217

Scaffold Caster Zinc Plated Yoke Nylon Bushing Bearing Wheel Size Grip ring stem total lock(Metal) Wheel Type

Sample Item Number



DL DOLLY

Portable/ Infinitely Expand/ Space Saving

KG 330Lbs
(Load Capacity)

PF PLATFORM TRUCK

Labor-saving/ Mute/ Innovative Button Handle

KG 400~840Lbs
(Load Capacity)

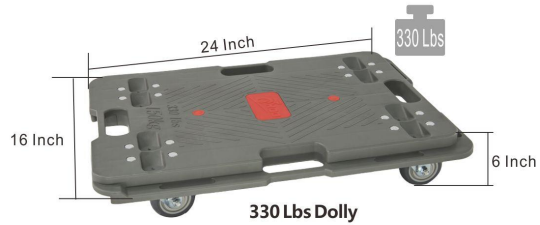

Products Configuration

Platform : PP **Wheel :** 4 pcs Swivel Caster
Fork finish : Zinc **Wheel materials :** PU

Features

Labor saving, more quiet and weight resistance.

Application

Widely used in hotels and logistics.

Model No.	Product Size (Inch)	Platform Height (Inch)	Wheel Dia (Inch)	Weight (Lbs)	Loading Capacity (Lbs)
D-150P	24x16	6	3	8	330

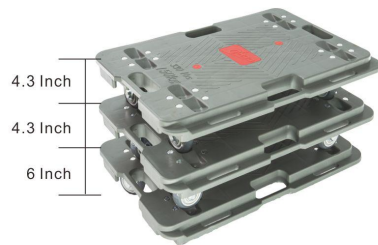

STACKABLE FOR STORAGE

First layer is 125MM, The second and third layer is 110MM to increase by degree.

Infinitely Expandable by Interlocking

STTD RING METHOD

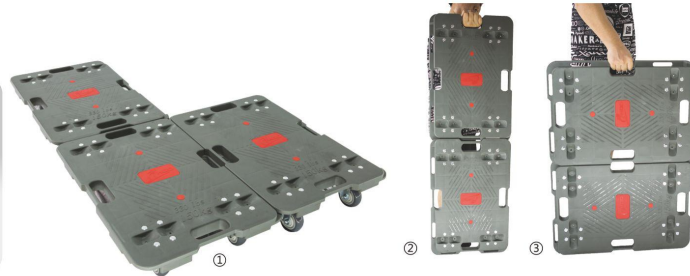

Product Configuration

Platform : PP **Handle :** 2.0MM Powder coated steel tube
Wheel : 2 pcs rigid and 2 pcs Swivel caster
Finish : Black color paint **Wheel Material :** TPR

Features

TPR wheels can be labor saving and more quiet.

Application

Widely used in hotels and warehouse.

Model No.	Product Size (Inch)	Platform Height (Inch)	Handle Height (Inch)	Wheel Dia (Inch)	Weight (Lbs)	Loading Capacity (Lbs)
PF180P	19x28	9	32	4	23	400
PF380P	24x35	8	36	5	35	840

INNOVATIVE BUTTON HANDLE



The reinforced platform structure makes the loading weight higher and more durable. No matter how much force the platform, it will not break.

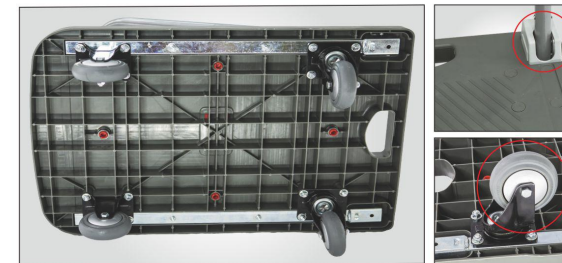

The unique design of mechanical protection that the truck will not break like traditional one.

Quiet caster



T1 SERIES **PLASTIC HAND TRUCK CASTER**



4" / 5"



140/150kg

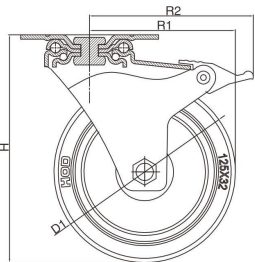

Spec.Demonstration



Wheel Option 4"/5"

4"/5" Black Color Paint Yoke



ER505

4" / 140kg

5" / 150kg

[Single Ball Bearing]
[Wheel Cross Section]

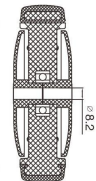

Top Plate Swivel

4" T1B1-4PS
5" T1B1-5PS

Top Plate Rigid

4" T1B1-4PR
5" T1B1-5PR

4" / 5"

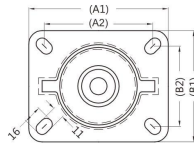
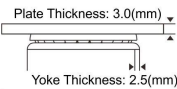

Conventional Plate

Wheel Dia (in)	Tread Width (mm)	Load Height (mm)	Swivel Radius (mm)	Plate Size (mm) (A1xB1)	Plate Size (mm) (A2xB2)	Hole Size (mm)
100 / 4"	32	131	85 / 107	100 x 80	77x57	11
125 / 5"	32	157	100.5 / 113	110 x 90	84.5x71	11



Sample Item Number

T1 B 1-4PR-ER505

Truck Caster Black Color Paint Single Ball Bearing Wheel Size Top Plate Rigid Wheel Type

WARRANTY

Each **SRC** product is warranted against defects in material and workmanship for one year from the date of original purchase, unless it has been misused, abused, modified, or improperly installed. Any product that is claimed to be defective and is returned to **SRC** with its prior written approval will be repaired or replaced free of charge, excluding freight and installation. This warranty is exclusive and there are no other warranties, express or implied, such as an implied warranty or merchantability or fitness for particular purchase. This remedy is the sole remedy in contract, tort, or otherwise, and **SRC** is not liable for incidental, consequential, or special damages.



Smooth Ride