

AN001 - 2.5kW Boost Power Factor Correction (PFC)

碳化硅MOSFET 2.5kW 功率因数校正模块

AZ-SiC-EVB-2.5kW-PFC

About this document

Scope and purpose

This application note provides an overview of the evaluation board AZ-SiC-EVB-2.5kW-PFC including its main features, key data, pin assignments and mechanical dimensions.

AZ-SiC-EVB-2.5kW-PFC is a complete evaluation board including one full-bridge diode rectifier that is composed by four Si switching devices and a boost power factor correction (PFC) that is composed by one SiC MOSFET and one SiC power diode. In combination with the control boards equipped with TI DSP TMS320F28379D, it features and demonstrates AZ Power's SiC MOSFETs for power factor correction applications.

The evaluation board AZ-SiC-EVB-2.5kW-PFC was developed to support customers to speed up their product development during their initial hardware design with the SiC power devices. The used SiC power device has a rated blocking voltage of 1200 V. It is optimized for power factor correction applications with very high switching frequency operation.

Intended audience

This application note is intended for power electronic engineers who wants to evaluate the performance of SiC devices in power factor correction applications.

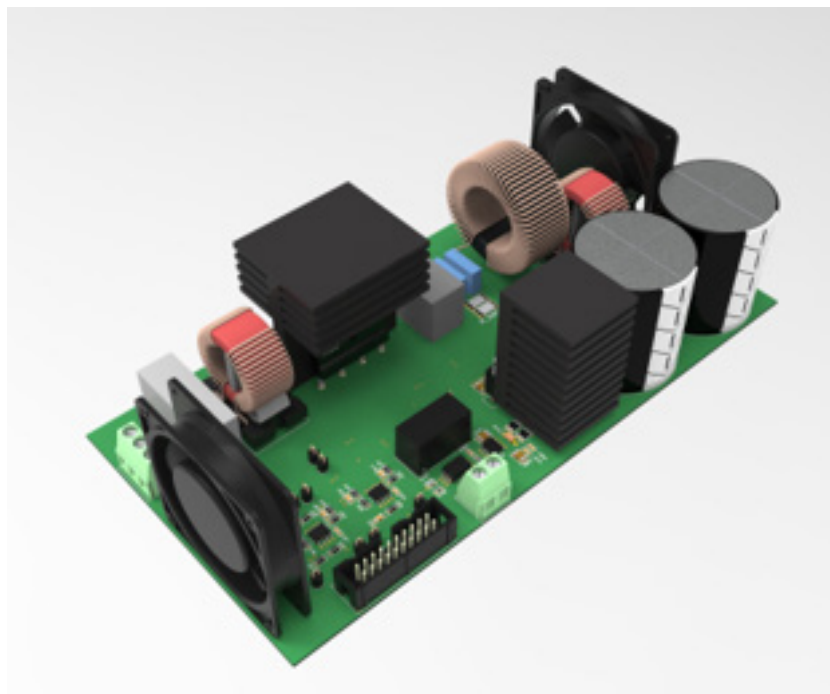

Table of Contents

About this document	1
1.Safety Precautions	3
2.Introduction	4
3.Design features	6
3.1. Detailed Specifications of The Evaluation Board	7
3.2. Functional Groups	8
3.3. Power Interface Pin Assignment	11
3.4. Sensing for Closed-loop Control	12
4. Revision History	12

1. Safety Precautions



CAUTION: DURING THE OPERATION OF THE BOARD DO NOT TOUCH THE EVALUATION BOARD WHEN IT IS POWERED BY ANY EXTERNAL POWER SOURCE. AND NEVER LEAVE THE EVALUATION BOARD UNATTENDED. THERE MAY HAVE VERY HIGH VOLTAGE PRESENTS ON THE EVALUATION BOARD.



CAUTION: BEFORE OPERATING THE BOARD THE EVALUATION BOARD MAY PRESENTS HIGH VOLTAGE DURING OPERATION. THE BULKY CAPACITORS WILL BE CHARGED BY EXTERNAL POWER SUPPLIES. BEFORE OPERATING THE BOARD, WAIT FOR 10 SECONDS TO ALLOW THE POWER SUPPLIES TO FULLY CHARGE ALL THE CAPACITORS AND GET THE WHOLE SYSTEM READY FOR OPERATION.



CAUTION: AFTER POWERING DOWN THE BOARD THE EVALUATION BOARD MAY PRESENTS HIGH VOLTAGE DURING OPERATION. THE BULKY CAPACITORS WILL BE CHARGED BY EXTERNAL POWER SUPPLIES. BEFORE WORKING ON THE EVALUATION BOARD, ALLOW THE BULKY CAPACITORS DISCHARGING FOR THREE MINUTES.



CAUTION: MEASUREMENT WHEN MEASUREMENT EQUIPMENTS ARE ABOUT TO CONNECT TO THE EVALUATION BOARD, USE HIGH-VOLTAGE DIFFERENTIAL PROBES. IF PASSIVE PROBES ARE INTENDED TO BE USED FOR MEASUREMENT, CONSULT POWER ELECTRONICS PROFESSIONALS FIRST. DO NOT CONNECT THE PROBE WHEN THE EVALUATION BOARD IS POWERED BY POWER SOURCE.



CAUTION: CONSEQUENCES PLEASE MAKE SURE THAT ALL MENTIONED SAFTY PROCEDURES ARE FOLLOWED WHEN USING THE EVALUATION BOARD. FAILED TO FOLLOW THE INSTRUCTIONS MAY LEAD TO:

- DEATH
- HEAT BURN
- SERIES INJURY
- ELECTROCUTION
- ELECTRICAL SHOCK
- ELECTRICAL BURN

2.Introduction

The AZ-SiC-EVB-2.5kW-PFC evaluation board is designed for the power factor correction application.

The boost PFC board is intended for use with a various of control boards. This evaluation board can be easily interfaced to control board via interface pin connectors.

This evaluation board is designed as an easy-to-use power stage based on AZ Power’s Silicon Carbide power devices. The evaluation board includes a main power connector for connecting the single-phase AC power grid, a main power connector for connecting the DC output, EMI filter, diode rectifier and a boost PFC power stage. The power stage also contains isolated current and voltage sensing circuits.

The AZ-SiC-EVB-2.5kW-PFC evaluation board is available via regular AZ Power distribution partners as well as on AZ Power’s website. The features of this board are described in the design feature chapter of this document. The remaining paragraphs provide information enabling customers to copy, modify and qualify the design for production according to their own specific requirements.

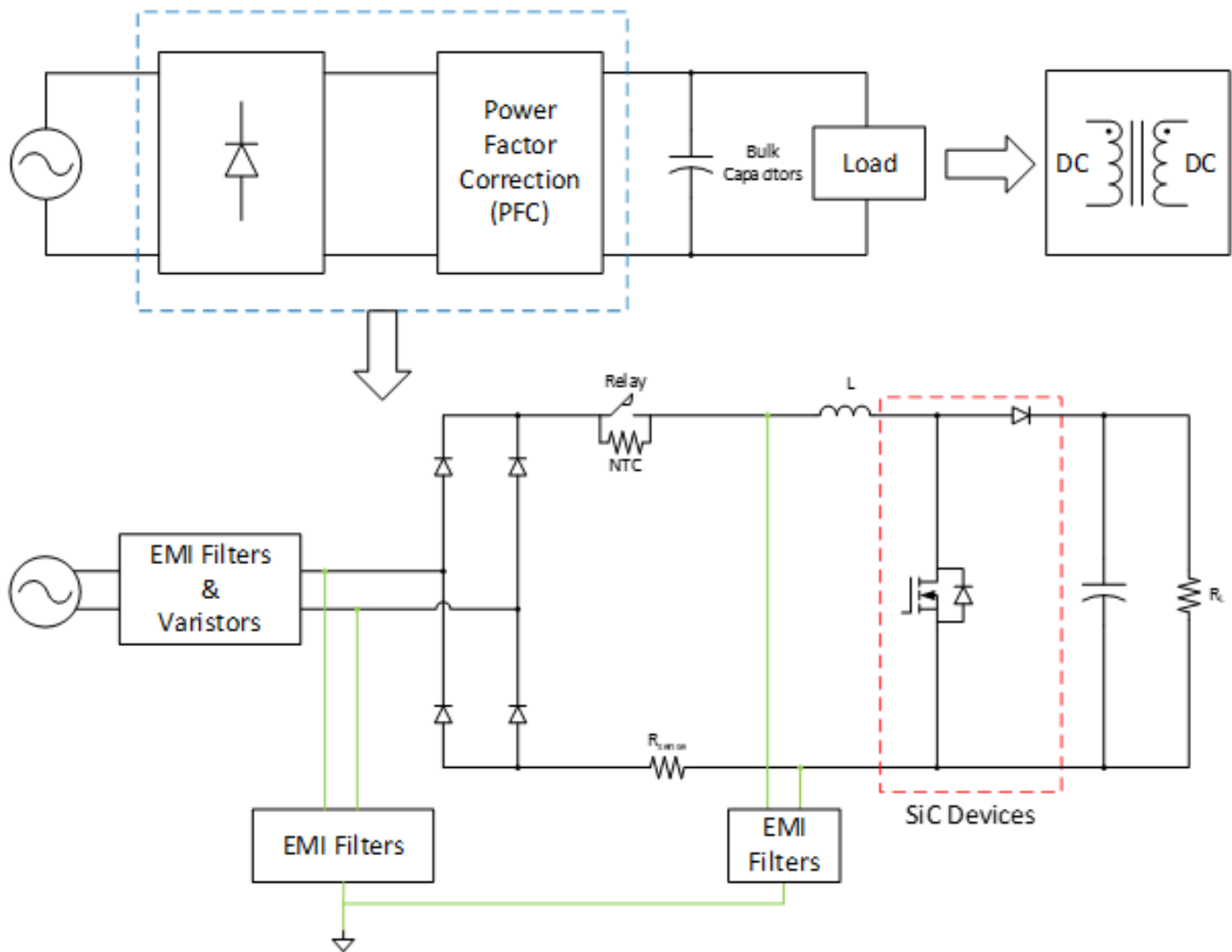

Figure 1. The schematic of the AZ-SiC-EVB-2.5kW-PFC evaluation board

Environmental conditions were considered in the design of the AZ-SiC-EVB-2.5kW-PFC. The design was tested as described in this document, but not qualified in terms of safety requirements, manufacturing and operation over the entire operating temperature range or lifetime. The boards provided by AZ Power are subject to functional testing only.

Evaluation boards are not subject to the same procedures as regular products regarding returned material analysis, process change notification and product discontinuation. Evaluation boards are intended to be used under laboratory conditions and by trained specialists only.

The block diagram of the AZ-SiC-EVB-2.5kW-PFC is depicted in Figure 1. This evaluation board includes EMI filters, a single-phase diode rectifier with a soft charge-up circuit, a series of auxiliary power supply to provide 12V, 5V and 3.3V, a series of voltage sensing and current sensing circuits and the PFC converter composed by silicon carbide power semiconductors. All the important control signals can be measured and observed via test points on the evaluation board. The hardware circuit relative to overcurrent protection can be implemented through programming the control board.

The signal processing circuitry of the evaluation board is fully isolated from the power circuitry by using isolated power supplies, isolated ICs and optocouplers. The design can be easily upgraded to a circuitry safe electrical insulation by replacing the present MOSFET drivers and the auxiliary power supplies that meets the safety requirement.

3.Design features

AZ-SiC-EVB-2.5kW-PFC is an evaluation board for PFC applications, which is composed of both silicon and silicon carbide power devices. By connecting to an appropriate control board that has compatible interface, it demonstrates AZ Power's silicon carbide power device technology.

Main features of the used power device from AZ Power:

- 1200 V SiC device with TO-247 package
- Lead-free terminal plating; RoHS compliant
- High reliability

The features of the evaluation board:

- Wide range AC voltage input
- Nominal 2.5 kW DC power output
- Continuous current operation
- On-board EMI filter
- Insulation between power circuitry and signal circuitry
- Isolated current sensing with current shunt resistors
- Isolated sensing by using high-linearity analog optocouplers
- Open loop protection (software)
- Auxiliary power needs to be provided separately in addition to the main AC power
- Measurement test points compatible with standard oscilloscope probes
- RoHS compliant
- Higher than 95% efficiency at 110 VAC
- THD < 5% and power factor > 99%

3.1. Detailed Specifications of The Evaluation Board

Parameters	Values	Comments
Input		
Input Voltage Range	90 VAC ~ 265 VAC	Single-Phase AC Voltage
Input Voltage Frequency	47 Hz ~ 63 Hz	
Output		
Output DC Voltage	400 VDC	
Nominal Output Power	2.5 kW	Ta=25°C, forced air cooling
Switching Frequency		
Nominal Switching Frequency f_{nom}	70 kHz	
Maximum Switching Frequency f_{max}	150 kHz	
Current Feedback		
Analog Signal to DSP	5mV/A	FCSL90R005FER shunt resistor
DC-Link Voltage Feedback		
Analog Signal to DSP	4.975 mV/V	
On Board Power Supply		
+12V	±5%	Used for analog circuits and power replay (e.g. AZ762)
5V	±5%	Used for analog circuits
3.3V	±2%	Used for analog circuits
System Environment		
Ambient Temperature	From 0 to 50°C	
PCB Information		
Material	FR4	
Dimension	TBA	

3.2. Functional Groups

The next two figures illustrate the functional groups on the top and bottom side of the evaluation board. And a third figure shows the side view of the evaluation board. The functional groups are explained in Table 1.

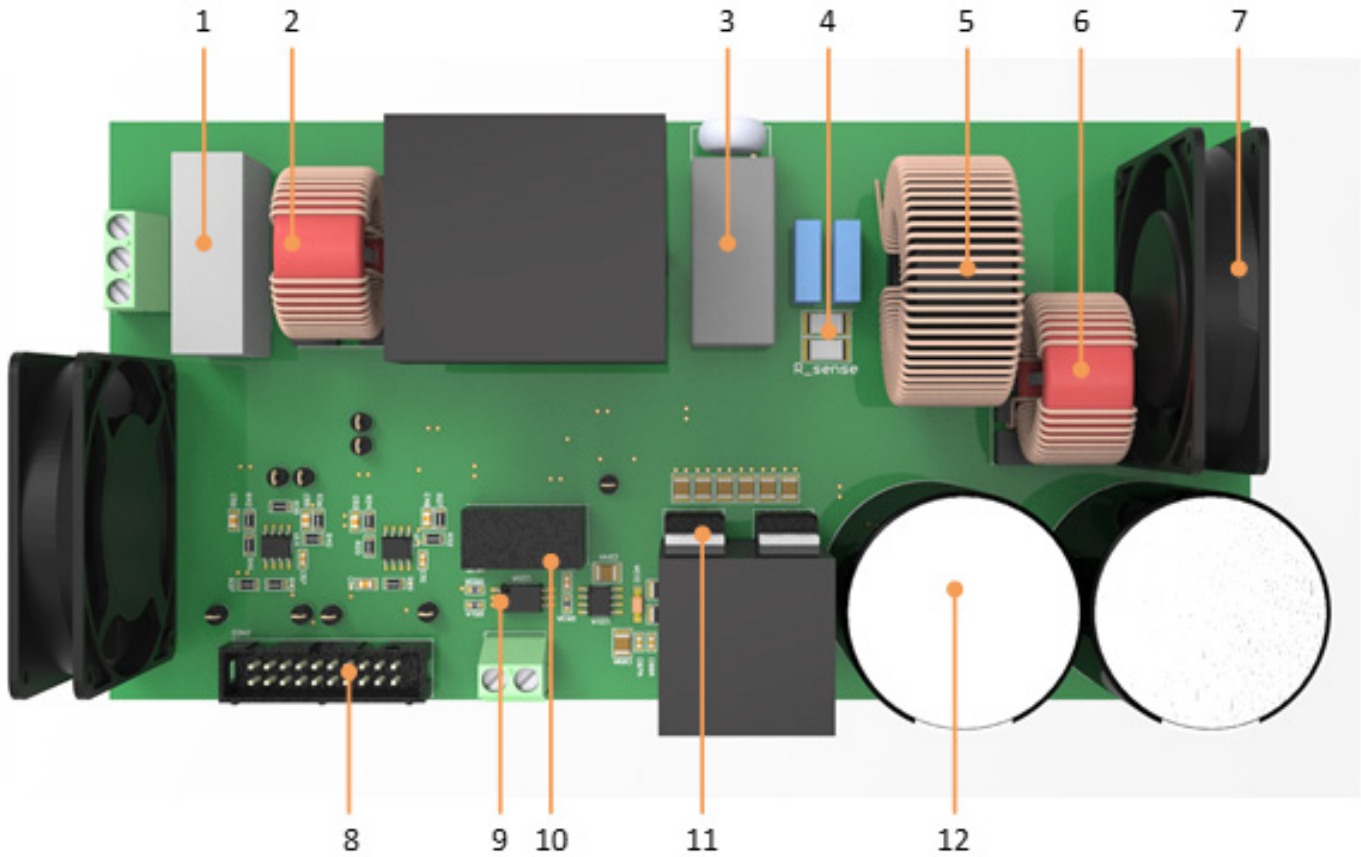

Figure 2. The top view of the AZ-SiC-EVB-2.5kW-PFC evaluation board

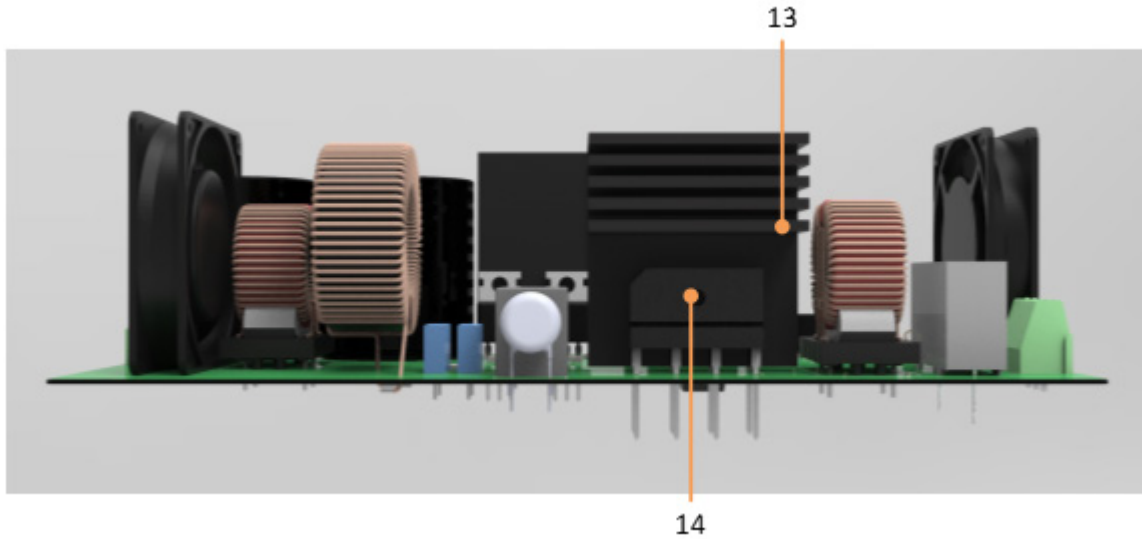

Figure 3. The side view of the AZ-SiC-EVB-2.5kW-PFC evaluation board

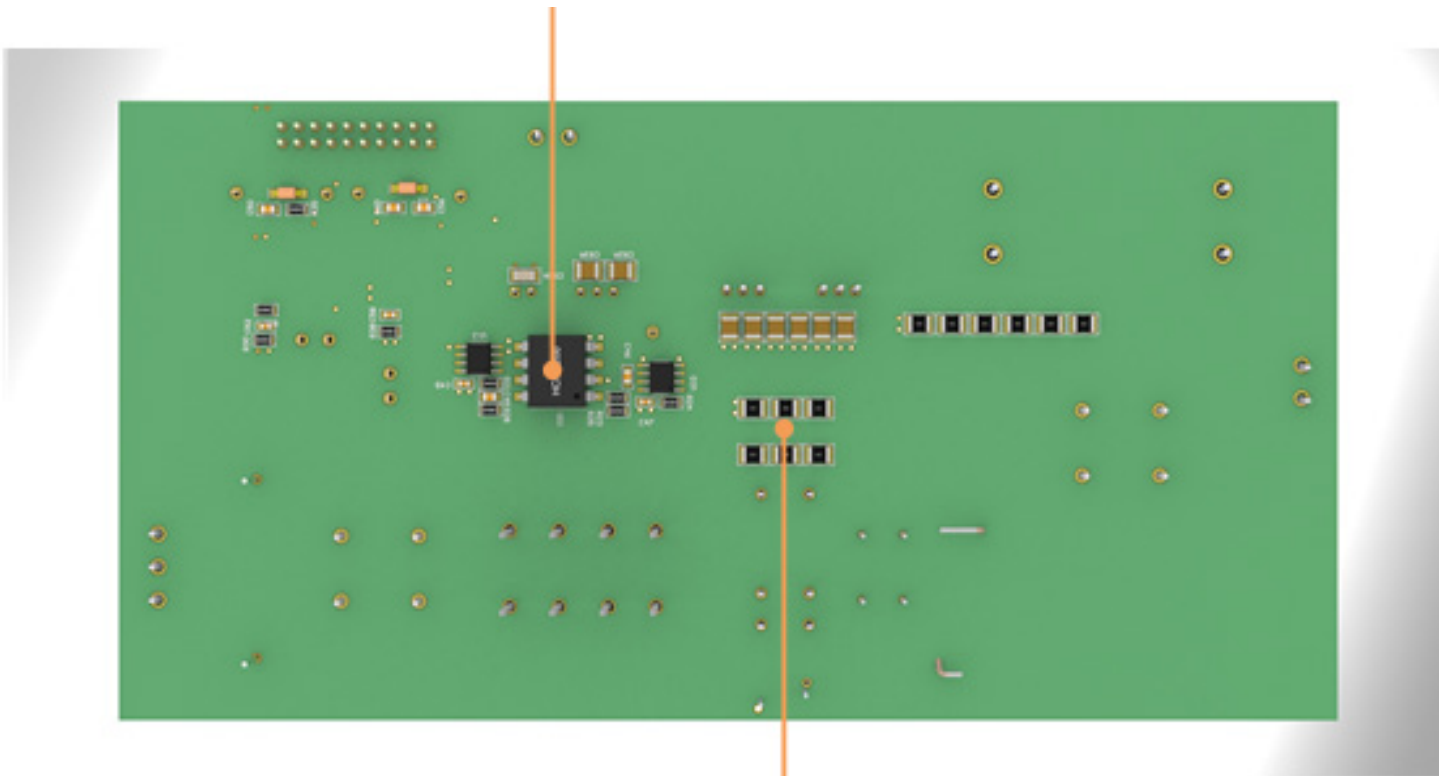

Figure 4. The bottom view of the AZ-SiC-EVB-2.5kW-PFC evaluation board

Table 1. Functional Groups of The Evaluation Board

Number	Functional Group
1	Varistors
2	single-phase common mode choke
3	Main power relay
4	Current sensing resistor
5	Main power inductor
6	Output choke
7	Cooling fan
8	Control board interface
9	Optocoupler signal processing circuitry
10	Isolated power supplies for gate driving circuitry
11	Power MOSFETS
12	Input DC-link capacitors
13	Heatsink
14	Rectifier
15	Input voltage sensing circuitry
16	Resistor voltage divider

3.3. Power Interface Pin Assignment

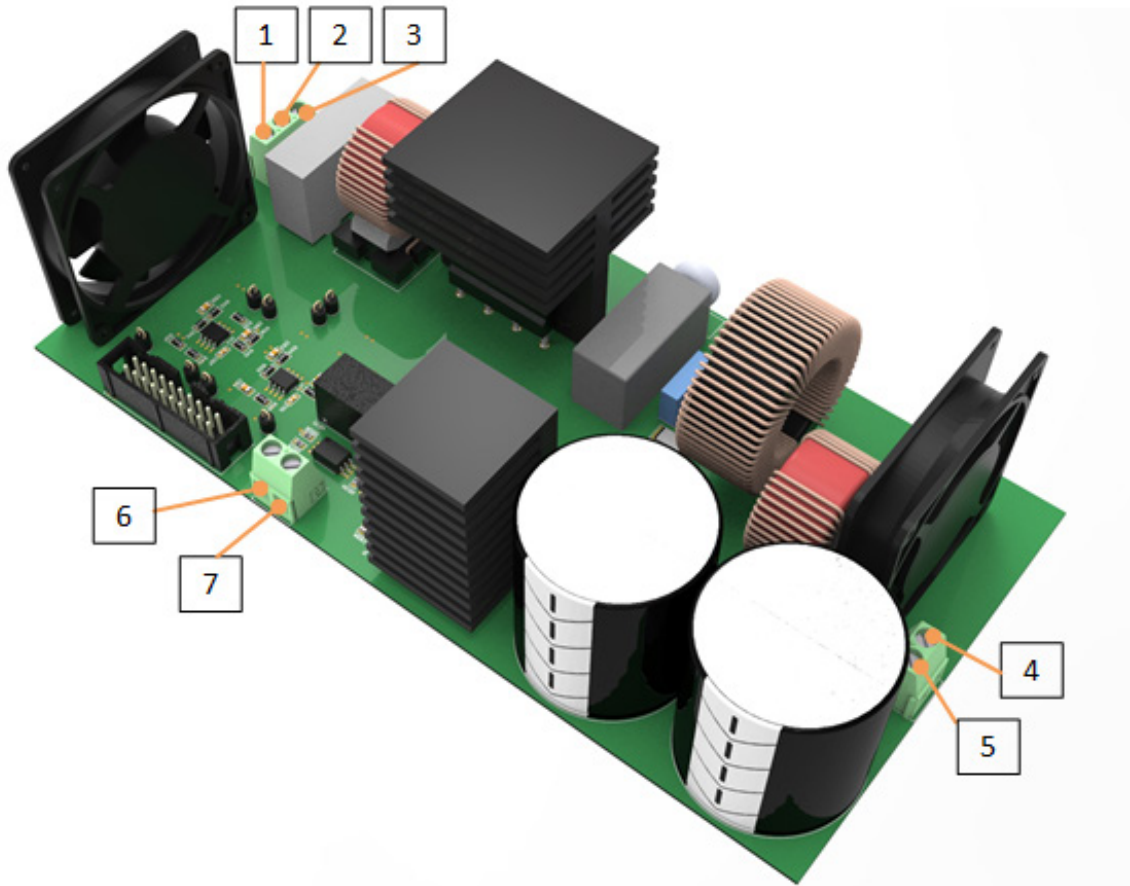

Figure 5. The power interface of the AZ-SiC-EVB-2.5kW-PFC evaluation board

Number	Pin	Comments
1	VAC_L	Phase A voltage input
2	VAC_N	Phase B voltage input
3	Earth	Earth ground
4	VDC+	DC voltage positive output
5	VDC-	DC voltage negative output
6	Aux_12V+	Auxiliary power positive input
7	Aux_12V-	Auxiliary power negative input

3.4. Sensing for Closed-loop Control

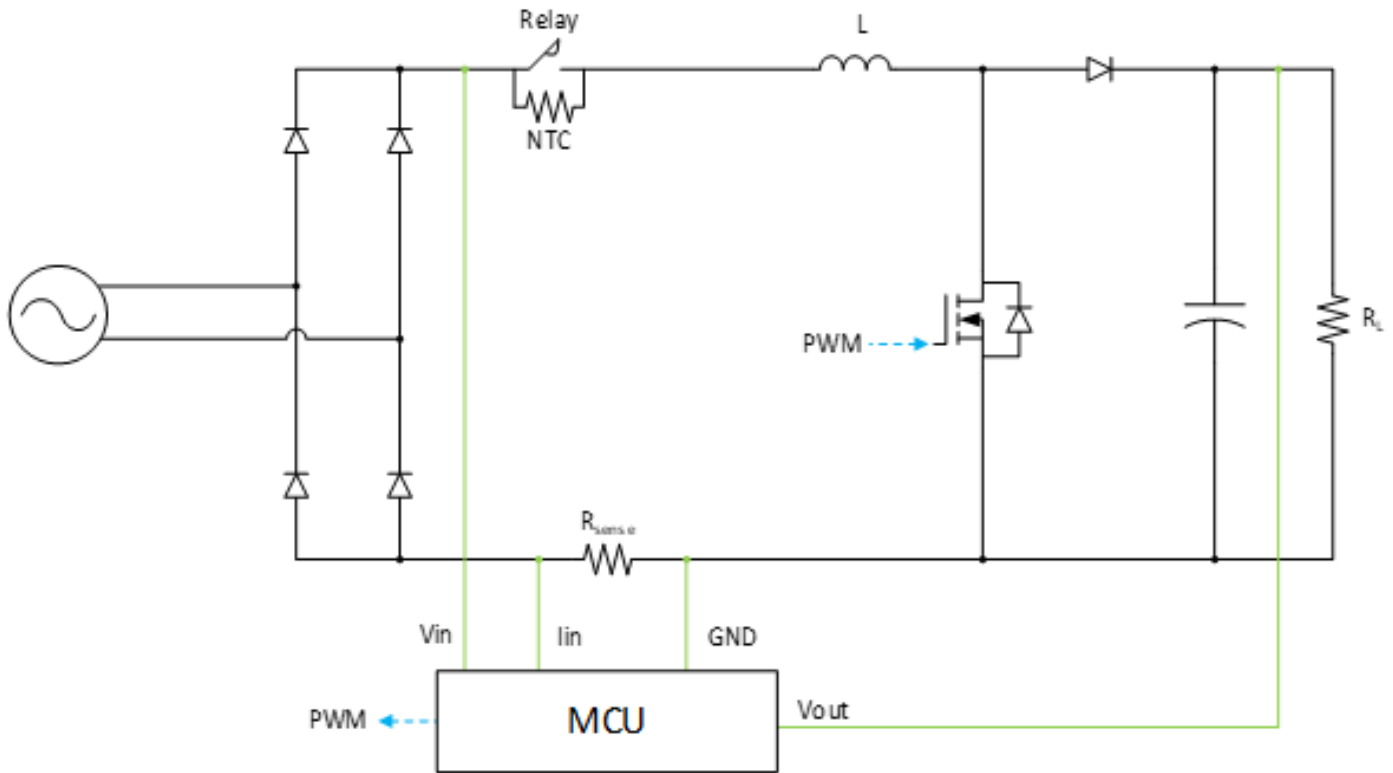

Figure 6. The PFC topology with sensing

4. Revision History

Major changes since last revision

Document version	Description of Change
1.0	Initial Version