

# AN002 - SiC MOSFET Evaluation Board for 10 kW Motor Drives

碳化硅 MOSFET 10kW 电机驱动器

**AZ-SiC-EVB-10kW-MD**

## About this document

### Scope and purpose

This application note provides an overview of the evaluation board AZ-SiC-EVB-10kW-MD including its main features, key data, pin assignments and mechanical dimensions.

AZ-SiC-EVB-10kW-MD is a complete evaluation board including three half-bridges that are composed by six SiC switching devices for motor drive applications. In combination with the control boards equipped with DSP TMS320F28379D, it features and demonstrates AZ Power's SiC MOSFETs for motor drive applications.

The evaluation board AZ-SiC-EVB-10kW-MD was developed to support customers to speed up their product development during their initial hardware design with the SiC power devices. The used power device has a rated blocking voltage of 1200 V at a typical on-state resistance of 25 mOhm. It is optimized for motor drive applications with very high switching frequency operation.

### Intended audience





This application note is intended for power electronic engineers who wants to evaluate the performance of SiC devices in motor drive applications.



## Table of Contents

About this document.....	1
Scope and purpose.....	1
Intended audience.....	1
1.Safety Precautions.....	3
2.Introduction.....	4
Figure 1. The block diagram of the AZ-SiC-EVB-10kW-MD.....	4
3.Design features.....	5
3.1. Detailed Specifications of The Evaluation Board.....	6
Figure 2. The top view of the AZ-SiC-EVB-10kW-MD evaluation board.....	7
Figure 3. The bottom view of the AZ-SiC-EVB-10kW-MD evaluation board.....	8
Table 1. Functional Groups of The Evaluation Board.....	9
3.3. Power Interface Pin Assignment.....	10
Figure 5. The power interface of the AZ-SiC-EVB-10kW-MD evaluation board.....	10
4. Revision History.....	11

## 1.Safety Precautions

	<p>CAUTION: DURING THE OPERATION OF THE BOARD DO NOT TOUCH THE EVALUATION BOARD WHEN IT IS POWERED BY ANY EXTERNAL POWER SOURCE. AND NEVER LEAVE THE EVALUATION BOARD UNATTENDED. THERE MAY HAVE VERY HIGH VOLTAGE PRESENTS ON THE EVALUATION BOARD.</p>
	<p>CAUTION: BEFORE OPERATING THE BOARD THE EVALUATION BOARD MAY PRESENTS HIGH VOLTAGE DURING OPERATION. THE BULKY CAPACITORS WILL BE CHARGED BY EXTERNAL POWER SUPPLIES. BEFORE OPERATING THE BOARD, WAIT FOR 10 SECONDS TO ALLOW THE POWER SUPPLIES TO FULLY CHARGE ALL THE CAPACITORS AND GET THE WHOLE SYSTEM READY FOR OPERATION.</p>
	<p>CAUTION: AFTER POWERING DOWN THE BOARD THE EVALUATION BOARD MAY PRESENTS HIGH VOLTAGE DURING OPERATION. THE BULKY CAPACITORS WILL BE CHARGED BY EXTERNAL POWER SUPPLIES. BEFORE WORKING ON THE EVALUATION BOARD, ALLOW THE BULKY CAPACITORS DISCHARGING FOR THREE MINUTES.</p>
	<p>CAUTION: MEASUREMENT WHEN MEASUREMENT EQUIPMENTS ARE ABOUT TO CONNECT TO THE EVALUATION BOARD, USE HIGH-VOLTAGE DIFFERENTIAL PROBES. IF PASSIVE PROBES ARE INTENDED TO BE USED FOR MEASUREMENT, CONSULT POWER ELECTRONICS PROFESSIONALS FIRST. DO NOT CONNECT THE PROBE WHEN THE EVALUATION BOARD IS POWERED BY POWER SOURCE.</p>
	<p>CAUTION: CONSEQUENCES PLEASE MAKE SURE THAT ALL MENTIONED SAFTY PROCEDURES ARE FOLLOWED WHEN USING THE EVALUATION BOARD. FAILED TO FOLLOW THE INSTRUCTIONS MAY LEAD TO:</p> <ul style="list-style-type: none"> <li>• DEATH</li> <li>• HEAT BURN</li> <li>• SERIES INJURY</li> <li>• ELECTROCUTION</li> <li>• ELECTRICAL SHOCK</li> <li>• ELECTRICAL BURN</li> </ul>

## 2.Introduction

The AZ-SiC-EVB-10kW-MD evaluation board is designed for the motor drive application.

The motor drive evaluation board is intended for use with a various of control boards. This evaluation board can be easily interfaced to control board via fiber optic and ribbon wires.

This evaluation board is designed as an easy-to-use power stage based on AZ Power's Silicon Carbide power devices. The evaluation board includes a three-phase AC connector for connecting the power grid, a three-phase AC connector for connecting the motor, EMI filter, diode rectifier and a three-phase power stage. The power stage also contains isolated current and voltage sensing circuits.

The AZ-SiC-EVB-10kW-MD evaluation board is available via regular AZ Power distribution partners as well as on AZ Power's website. The features of this board are described in the design feature chapter of this document. The remaining paragraphs provide information enabling customers to copy, modify and qualify the design for production according to their own specific requirements.

Environmental conditions were considered in the design of the AZ-SiC-EVB-10kW-MD. The design was tested as described in this document, but not qualified in terms of safety requirements, manufacturing and operation over the entire operating temperature range or lifetime. The boards provided by AZ Power are subject to functional testing only.

Evaluation boards are not subject to the same procedures as regular products regarding returned material analysis, process change notification and product discontinuation. Evaluation boards are intended to be used under laboratory conditions and by trained specialists only.

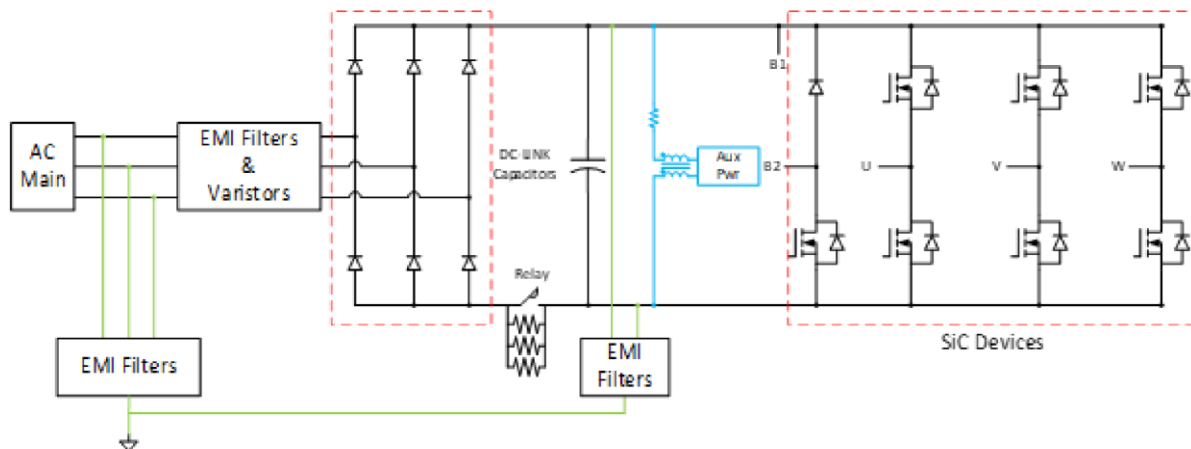

**Figure 1. The block diagram of the AZ-SiC-EVB-10kW-MD**

The block diagram of the AZ-SiC-EVB-10kW-MD is depicted in Figure 1. This evaluation board includes an EMI filter, a three-phase diode rectifier with a soft charge-up circuit, a series of auxiliary power supply to provide 12V, 5V and 3.3V, and the silicon carbide power semiconductors. All the important control signals can be measured and observed via test points on the evaluation board. The hardware circuit relative to overcurrent protection can be implemented through programming control board.

The signal processing circuitry of the evaluation board is fully isolated from the power circuitry by using isolated power supplies, isolated ICs, fiber optics and optocouplers. The design can be easily upgraded to a circuitry safe electrical insulation by replacing the present MOSFET drivers and the auxiliary power supplies that meets the safety requirement.

### **3.Design features**

AZ-SiC-EVB-10kW-MD is an evaluation board for motor drive applications, which is composed of multiple silicon carbide power devices. By connecting to an appropriate control board with compatible interface, it demonstrates AZ Power's silicon carbide power device technology.

Main features of the power device:

- 1200 V / 25 mΩ SiC MOSFET with TO-247 package
- Lead-free terminal plating; RoHS compliant
- Low inductive design

The features of the evaluation board:

- 220 VAC input voltage
- Nominal 10 kW motor power output
- Maximum 20 kW motor power output
- On-board EMI filter
- Insulation between power circuitry and signal circuitry
- Isolated current sensing with LEM current sensors
- Isolated sensing of dc-link voltage by high-linearity analog optocouplers
- Overload and short-circuit software protection
- Overtemperature software protection
- All six switches turn off during protection
- Auxiliary power abstracted from the main power source directly
- Measurement test points compatible with standard oscilloscope probes
- PCB is 295mm\*267mm in size, and has four layers with 3oz copper for each
- RoHS compliant
- Max efficiency 99%

### 3.1. Detailed Specifications of The Evaluation Board

Parameters	Values	Comments
<b>Input</b>		
Voltage	3 Phase 220 V <sub>L-L</sub>	3 Phase Line-to-Line Voltage
<b>Output</b>		
Output Line-to-Line Voltage	220 VAC	
3-Phase Output Power (Max)	20 kW	Ta=25°C, forced air cool
3-Phase Output Power (Nominal)	10 kW	Ta=25°C, forced air cooling
<b>Switching Frequency</b>		
Nominal Switching Frequency $f_{nom}$	20 kHz	
Maximum Switching Frequency $f_{max}$	100 kHz	
<b>Current Feedback</b>		
Analog Signal to DSP	9.2 mV/A	
<b>DC-Link Voltage Feedback</b>		
Analog Signal to DSP	4.975 mV/V	
<b>On Board Power Supply</b>		
+12V	±5%	Used for analog circuits and power replay
5V	±5%	Used for analog circuits
3.3V	±2%	Used for analog circuits
<b>System Environment</b>		
Ambient Temperature	From 0 to 50°C	
<b>PCB Information</b>		
Material	FR4	
Dimension	295 x 267 mm	

### 3.2 Functional Groups

The next two figures illustrate the functional groups on the top and bottom side of the evaluation board. And a third figure shows the side view of the evaluation board. The functional groups are explained in Table 1.

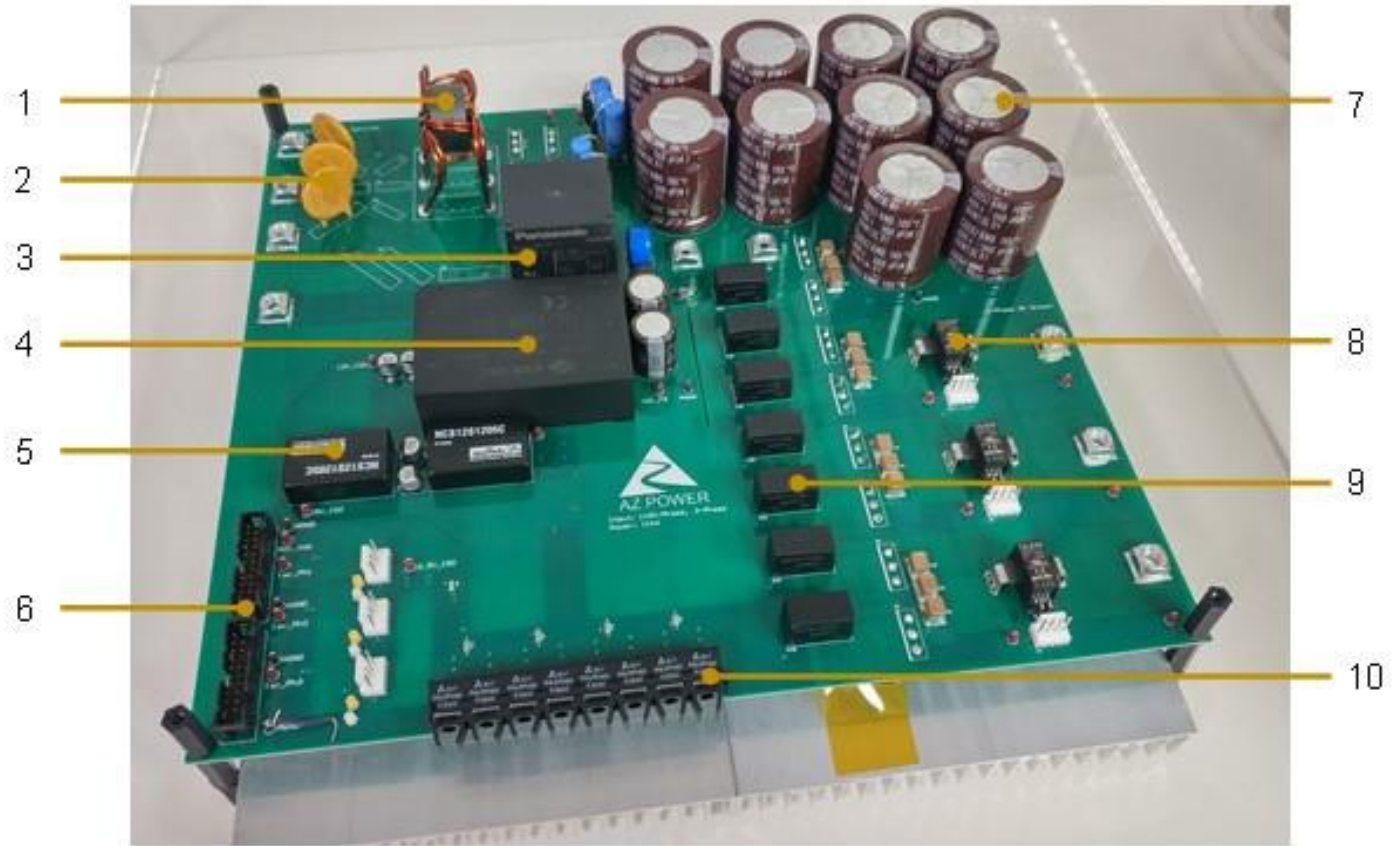

**Figure 2. The top view of the AZ-SiC-EVB-10kW-MD evaluation board**

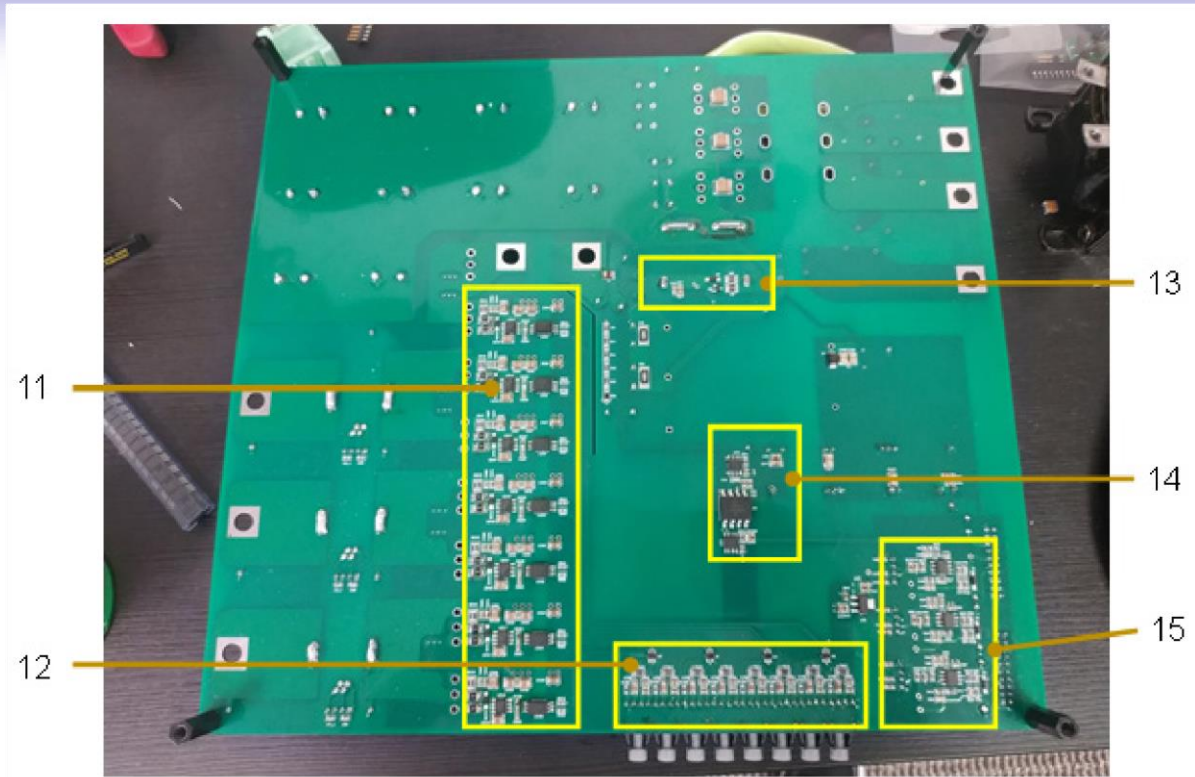

**Figure 3. The bottom view of the AZ-SiC-EVB-10kW-MD evaluation board**

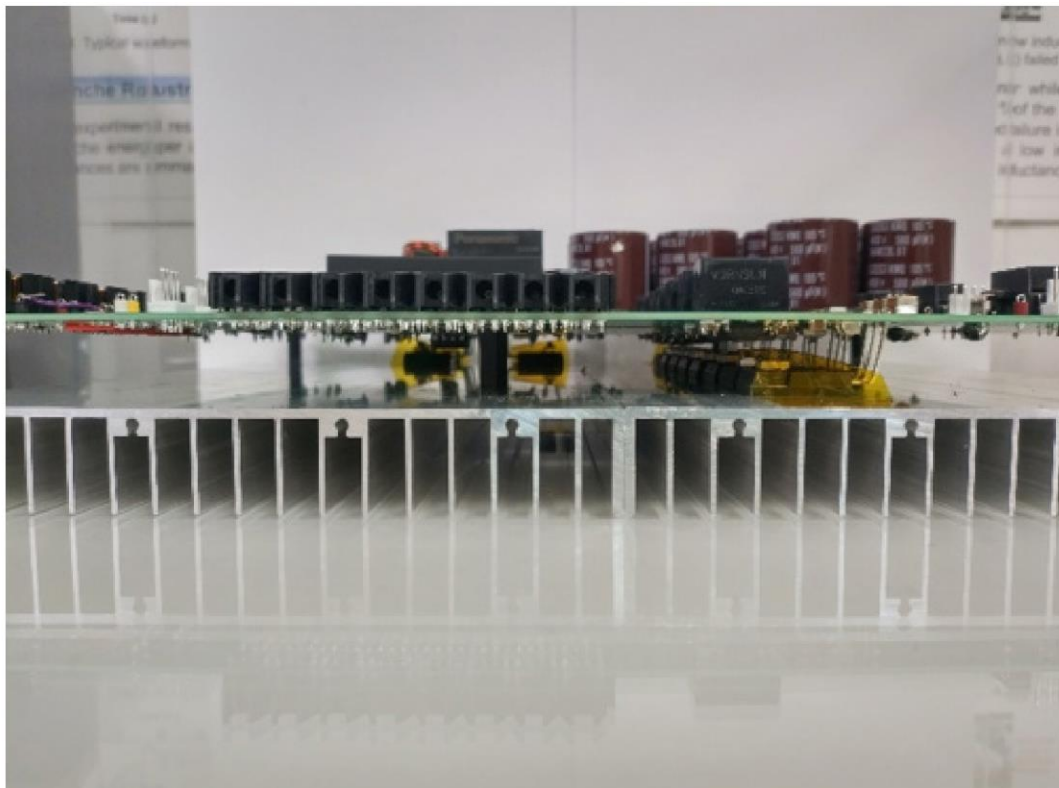

**Figure 4. The side view of the AZ-SiC-EVB-10kW-MD evaluation board**



**Table 1. Functional Groups of The Evaluation Board**

Number	Functional Group
1	3-phase common mode choke
2	Varistors
3	Main power relay
4	Isolated auxiliary power supply for all analog circuits and power replay
5	Isolated auxiliary power supply
6	Sensing signal feedback interface
7	DC-link capacitors
8	Hall effect current sensors
9	Isolated power supplies for gate driving circuitry
10	Fiber optic receivers and transmitters
11	MOSFET gate driving circuitry
12	Fiber optic signal processing circuitry
13	Power replay driving circuitry
14	DC-link voltage sensing circuitry
15	Signal conditioning circuitry for all sensed signals

### 3.3. Power Interface Pin Assignment

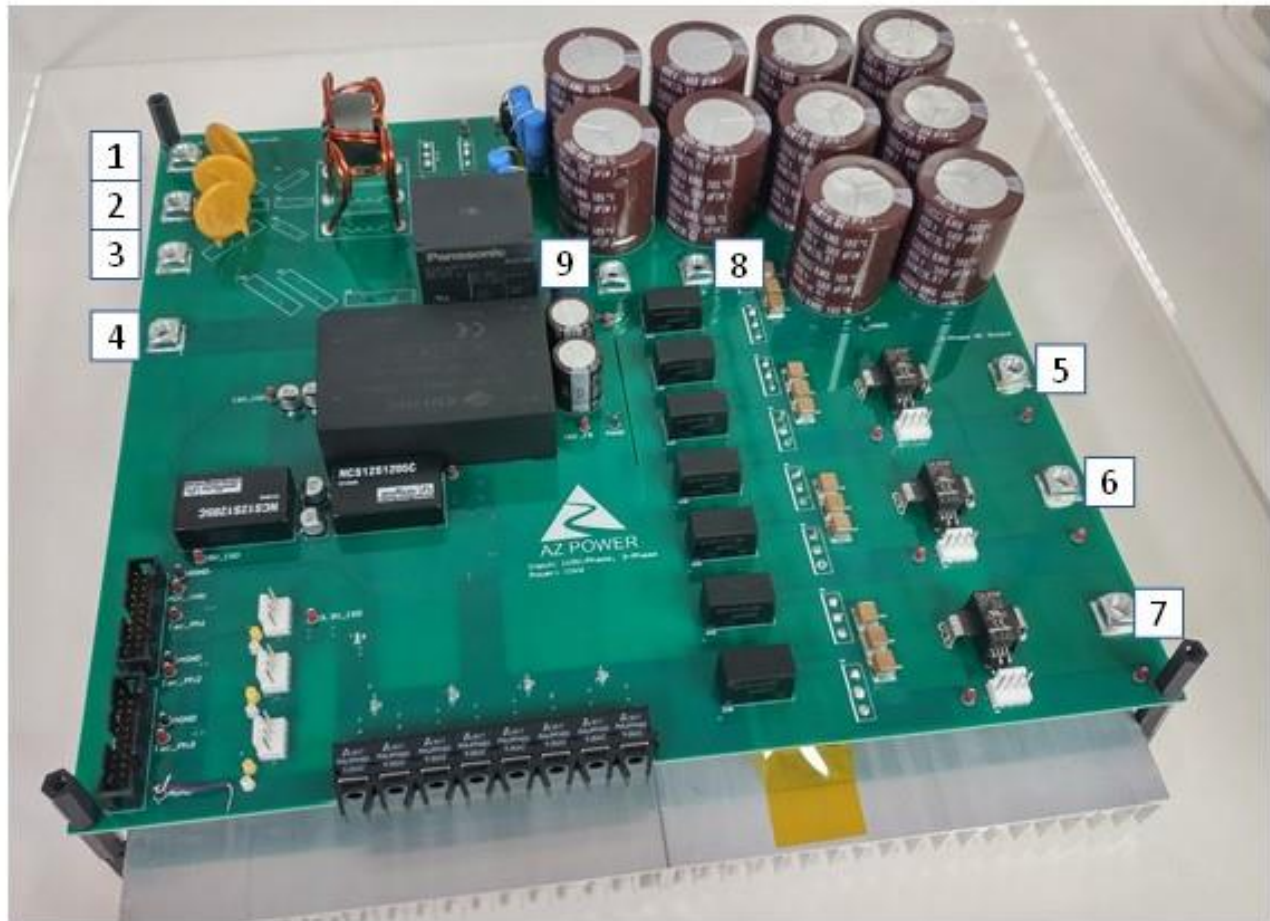

**Figure 5. The power interface of the AZ-SiC-EVB-10kW-MD evaluation board**

Number	Pin	Comments
1	V_A	Phase A voltage input
2	V_B	Phase B voltage input
3	V_C	Phase C voltage input
4	Earth	Earth ground
5	I_U	Phase U current output
6	I_V	Phase V current output
7	I_W	Phase W current output
8	B2	Break
9	B1	DC+

#### **4. Revision History**

Major changes since last revision

<b>Document version</b>	<b>Description of change</b>
1.0	Initial version