

AN006 – 45W Flyback Converter

碳化硅MOSFET 45W 反激变换器

AZ-SiC-EVB-45W-FB

About this document

Scope and purpose

This application note provides an overview of the evaluation board AZ-SiC-EVB-45W-FB including its main features, key data, pin assignments and mechanical dimensions.

AZ-SiC-EVB-45W-FB is a complete evaluation board including one SiC power switching devices, synchronous rectifier that is composed of multiple Si MOSFET and an output Si MOSFET. In combination with the on-board controllers, it features and demonstrates AZ Power's SiC MOSFETs for data center and telecom power supply applications.

The evaluation board AZ-SiC-EVB-45W-FB was developed to support customers to speed up their product development during their initial hardware design with the SiC power devices. The used SiC power device has a rated blocking voltage of 1200 V. It is optimized for quasi-resonant flyback converters with very high switching frequency operation.

Intended audience

This application note is intended for power electronic engineers who want to evaluate the performance of SiC devices in soft-switching flyback converter applications.

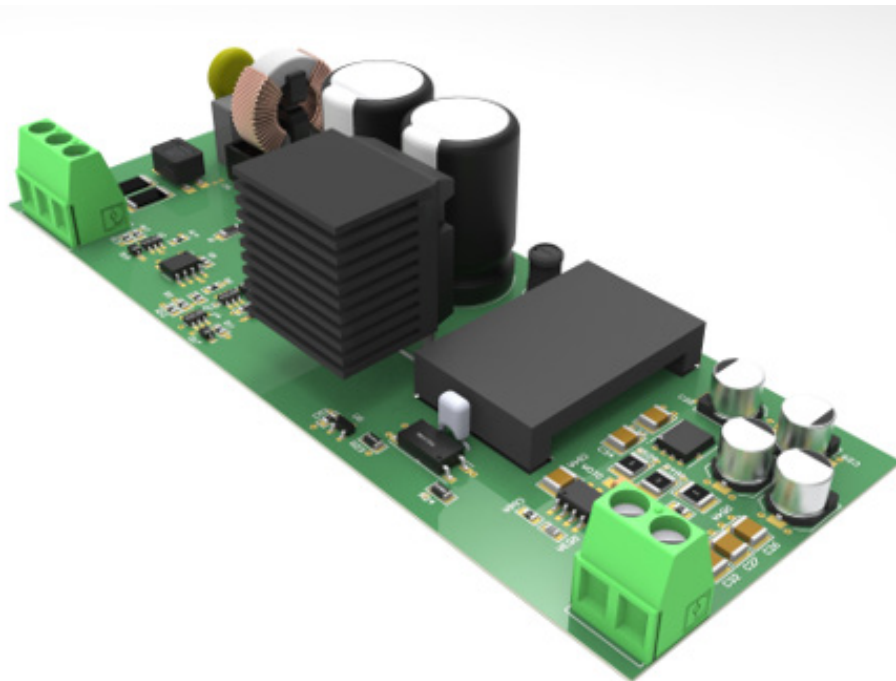









Table of Contents

About this document	1
1.Safety Precautions	3
2.Introduction	4
3.Design features	5
3.1. Detailed Specifications of The Evaluation Board	6
3.2. Functional Groups	7
3.3. Power Interface Pin Assignment.....	10
4. Revision History	11

1. Safety Precautions

	<p>CAUTION: DURING THE OPERATION OF THE BOARD DO NOT TOUCH THE EVALUATION BOARD WHEN IT IS POWERED BY ANY EXTERNAL POWER SOURCE. AND NEVER LEAVE THE EVALUATION BOARD UNATTENDED. THERE MAY HAVE VERY HIGH VOLTAGE PRESENTS ON THE EVALUATION BOARD.</p>
	<p>CAUTION: BEFORE OPERATING THE BOARD THE EVALUATION BOARD MAY PRESENTS HIGH VOLTAGE DURING OPERATION. THE BULKY CAPACITORS WILL BE CHARGED BY EXTERNAL POWER SUPPLIES. BEFORE OPERATING THE BOARD, WAIT FOR 10 SECONDS TO ALLOW THE POWER SUPPLIES TO FULLY CHARGE ALL THE CAPACITORS AND GET THE WHOLE SYSTEM READY FOR OPERATION.</p>
	<p>CAUTION: AFTER POWERING DOWN THE BOARD THE EVALUATION BOARD MAY PRESENTS HIGH VOLTAGE DURING OPERATION. THE BULKY CAPACITORS WILL BE CHARGED BY EXTERNAL POWER SUPPLIES. BEFORE WORKING ON THE EVALUATION BOARD, ALLOW THE BULKY CAPACITORS DISCHARGING FOR THREE MINUTES.</p>
	<p>CAUTION: MEASUREMENT WHEN MEASUREMENT EQUIPMENTS ARE ABOUT TO CONNECT TO THE EVALUATION BOARD, USE HIGH-VOLTAGE DIFFERENTIAL PROBES. IF PASSIVE PROBES ARE INTENDED TO BE USED FOR MEASUREMENT, CONSULT POWER ELECTRONICS PROFESSIONALS FIRST. DO NOT CONNECT THE PROBE WHEN THE EVALUATION BOARD IS POWERED BY POWER SOURCE.</p>
	<p>CAUTION: CONSEQUENCES PLEASE MAKE SURE THAT ALL MENTIONED SAFTY PROCEDURES ARE FOLLOWED WHEN USING THE EVALUATION BOARD. FAILED TO FOLLOW THE INSTRUCTIONS MAY LEAD TO:</p> <ul style="list-style-type: none"> • DEATH • HEAT BURN • SERIES INJURY • ELECTROCUTION • ELECTRICAL SHOCK • ELECTRICAL BURN

2.Introduction

The AZ-SiC-EVB-45W-FB evaluation board is designed for the portable power adaptor and auxiliary power supply application, based on quasi-resonant flyback converter topology.

The quasi-resonant flyback converter board is equipped with on-board controllers, on both of the primary side and secondary side of the evaluation board. An additional control board is not needed.

This evaluation board is designed as an easy-to-use power stage based on AZ Power's Silicon Carbide power devices. The evaluation board includes a main power connector for connecting the high voltage AC line, a main power connector for connecting the low voltage DC output, EMI filter, bulky capacitors, transformer and flyback converter power stage. The power stage also contains control circuits.

The AZ-SiC-EVB-45W-FB evaluation board is available via regular AZ Power distribution partners as well as on AZ Power's website. The features of this board can be found in the design feature chapter of this document. The remaining paragraphs provide information enabling customers to copy, modify and qualify the design for production according to their own specific requirements.

Environmental conditions were considered in the design of the AZ-SiC-EVB-45W-FB. The design was tested as described in this document, but not qualified in terms of safety requirements, manufacturing and operation over the entire operating temperature range or lifetime. The boards provided by AZ Power are subject to functional testing only.

Evaluation boards are not subject to the same procedures as regular products regarding returned material analysis, process change notification and product discontinuation. Evaluation boards are intended to be used under laboratory conditions and by trained specialists only.

The block diagram of the AZ-SiC-EVB-45W-FB is depicted in Figure 1. This evaluation board includes EMI filters, one primary side PWM controller, one secondary side synchronous rectifier controller, current sensing circuits and quasi-resonant flyback converter composed by silicon carbide semiconductor. All the important control signals can be measured and observed via test points on the evaluation board. The hardware circuit relative to overcurrent protection is implemented through the controller ICs.

The signal processing circuitry of the evaluation board is fully isolated from the power circuitry by using optocouplers. The design may be easily upgraded to a circuitry safe electrical insulation by replacing the present MOSFET drivers, opto-coupler and the controller ICs that meets the safety requirement.

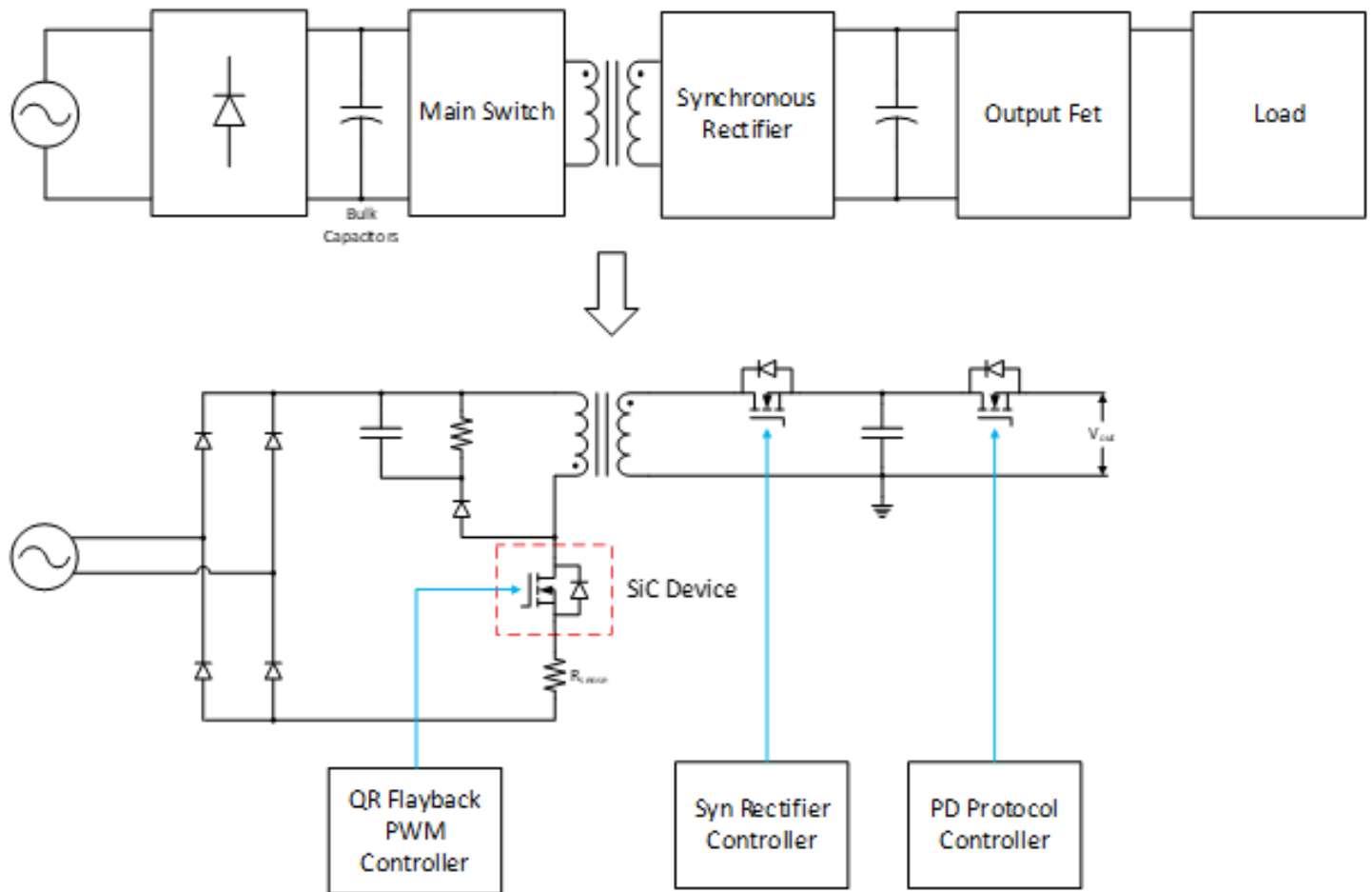

Figure 1. The schematic of the AZ-SiC-EVB-45W-FB evaluation board

3.Design features

AZ-SiC-EVB-45W-FB is an evaluation board for portable power adaptor and auxiliary power supply applications, which is composed of both silicon and silicon carbide power devices. By using appropriate controller ICs that are specially designed for quasi-resonant flyback converter application, it demonstrates AZ Power's silicon carbide power device technology.

Main features of the used power device from AZ Power:

- 1200V SiC MOSFET with TO-220 package
- Lead-free terminal plating; RoHS compliant
- High reliability

The features of the evaluation board:

- Wide range AC voltage input
- Nominal 45W DC power output
- Configurable output voltage (e.g. 5V, 9V, 12V, 15V)
- Resonant operation
- On-board EMI filter
- On-board controllers
- Insulation between primary side circuit and secondary side circuit
- Non-Isolated voltage sensing on the secondary side, feedback to IC through opto-coupler
- Over current protection and short circuit protection
- Auxiliary power provided through the main AC power
- Measurement test points compatible with standard oscilloscope probes
- RoHS compliant
- Higher than 95% peak efficiency

3.1. Detailed Specifications of The Evaluation Board

Parameters	Values	Comments
Input		
Input Voltage	90 VAC ~ 240 VAC	
Output		
Typical Output DC Voltage #1	5 VDC	
Maximum Output Current #1	3 A	Ta=25°C
Typical Output DC Voltage #2	9 VDC	
Maximum Output Current #2	3 A	Ta=25°C
Typical Output DC Voltage #3	12 VDC	
Maximum Output Current #3	3 A	Ta=25°C
Typical Output DC Voltage #4	15 VDC	
Maximum Output Current #4	3 A	Ta=25°C
Voltage Ripple	0.1 V	
Switching Frequency		
Nominal Switching Frequency f_{nom}	100 kHz	
Maximum Switching Frequency f_{max}	200 kHz	
Current Feedback		
Analog Signal to DSP (Primary)	50 mV/A	Use current sense transformer
Analog Signal to DSP (Secondary)	10 mV/A	Based on paralleled 1mOhm shunt
Output Voltage Feedback		
Analog Signal to Controller	0.5 V	Vout = 15V
Standby Power		
Maximum Power @ 5 V	50 mW	Input 230 VAC (No load)
System Environment		
Ambient Temperature	From 0 to 50°C	
PCB Information		
Material	FR4	
Dimension	TBA	

3.2. Functional Groups

The next two figures illustrate the functional groups on the top and bottom side of the evaluation board. And a third figure shows the side view of the evaluation board. The functional groups are explained in Table 1.

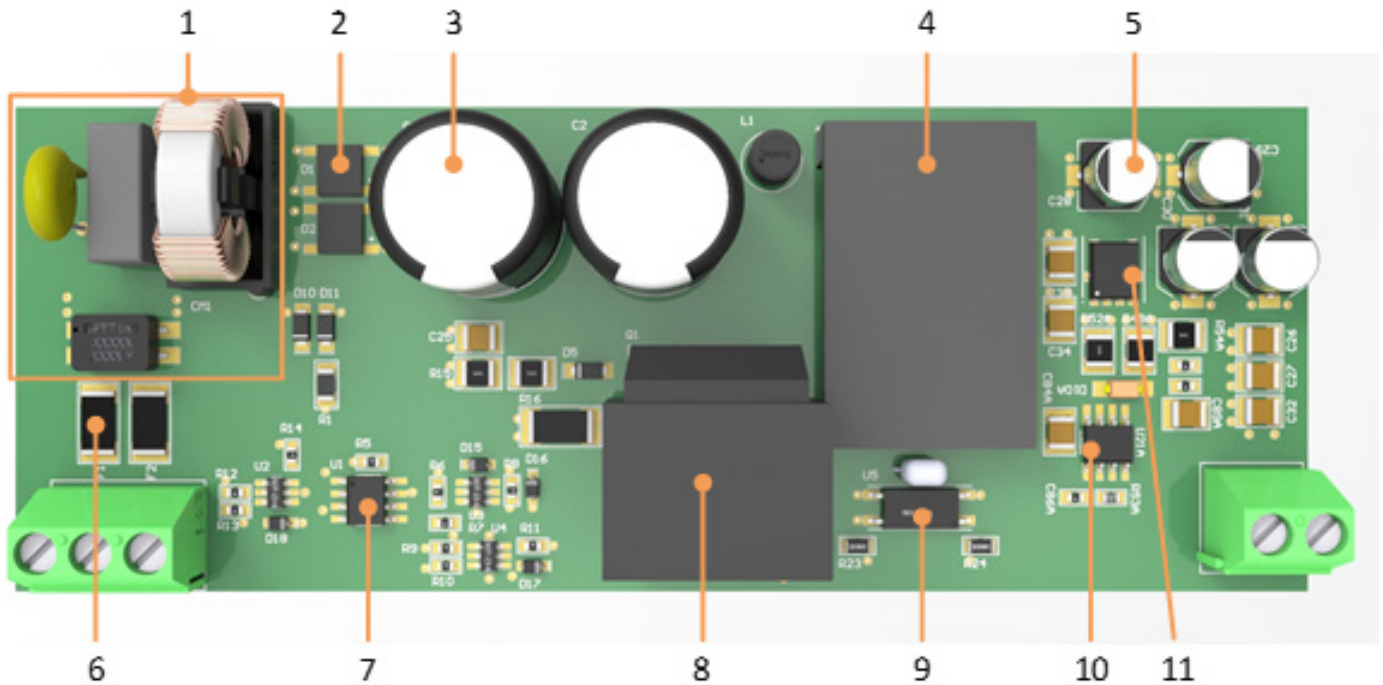

Figure 2. The top view of the AZ-SiC-EVB-45W-FB evaluation board

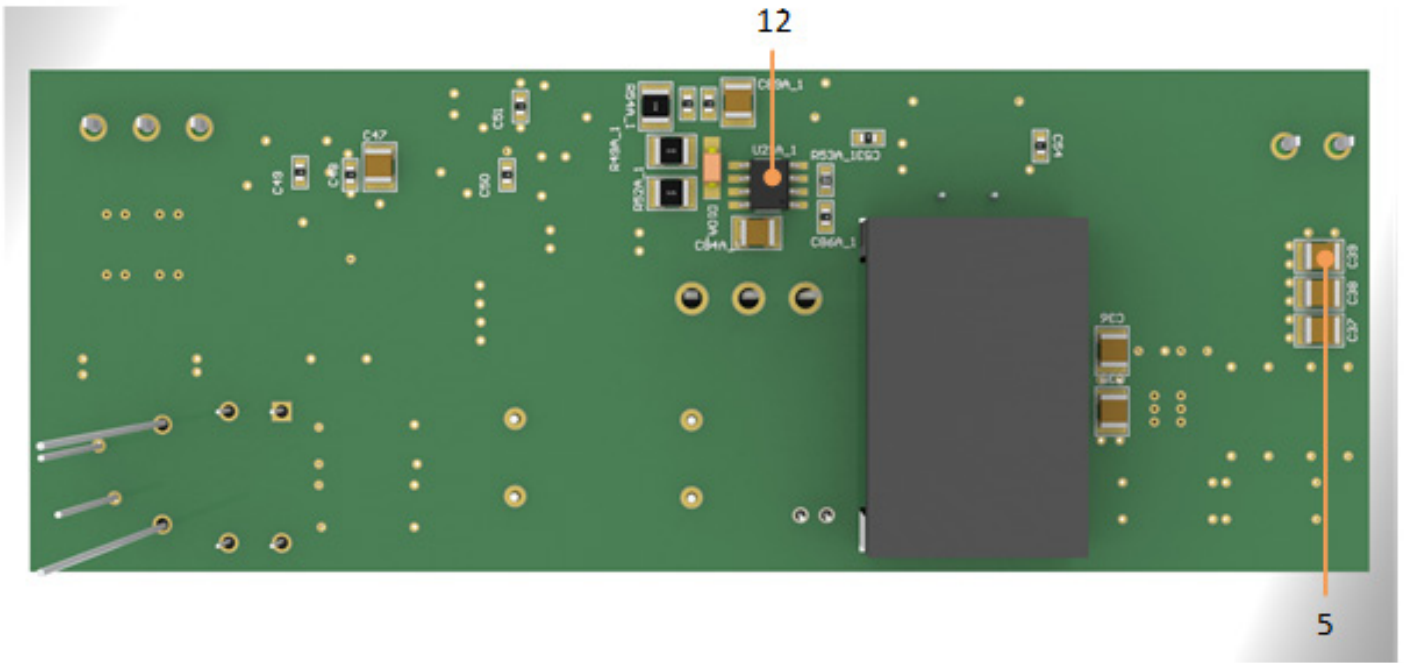

Figure 3. The bottom view of the AZ-SiC-EVB-45W-FB evaluation board

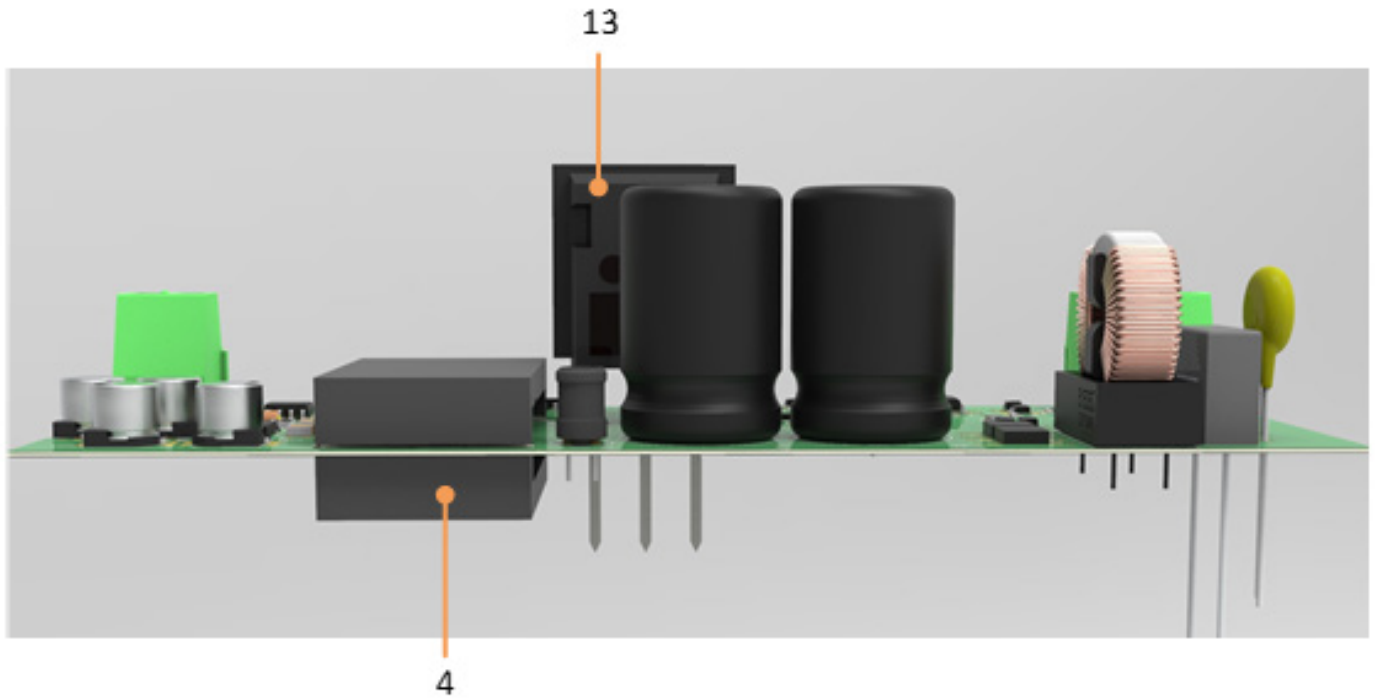

Figure 4. The side view of the AZ-SiC-EVB-45W-FB evaluation board

Table 1. Functional Groups of The Evaluation Board

Number	Functional Group
1	Common mode filters
2	Power rectifiers
3	Input DC-link capacitors
4	Main power planar transformers
5	Output DC-link capacitors
6	Fuses
7	Primary side PWM controller
8	Heatsink
9	Opto-coupler for output voltage feedback
10	Secondary side synchronous rectifier controller
11	Secondary side synchronous rectifier
12	MOSFET gate driving circuitry
13	Primary side power MOSFET

3.3. Power Interface Pin Assignment

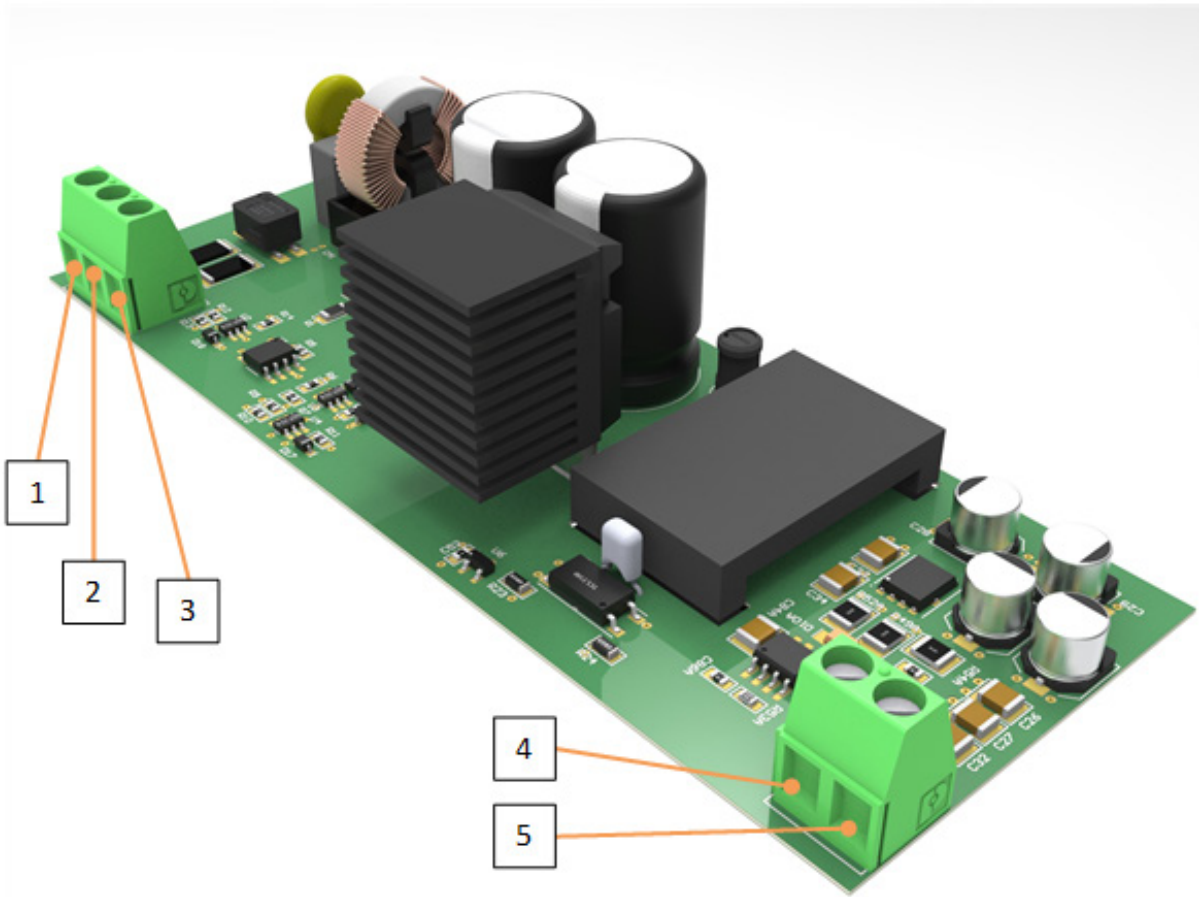

Figure 5. The power interface of the AZ-SiC-EVB-45W-FB evaluation board

Number	Pin	Comments
1	Input_VAC line	AC voltage input line
2	Input_VAC netural	AC voltage input netural
3	Earth	Earth ground
4	Output_VDC+	DC voltage positive output
5	Output_VDC-	DC voltage negative output

3.4. Sensing for Closed-loop Control

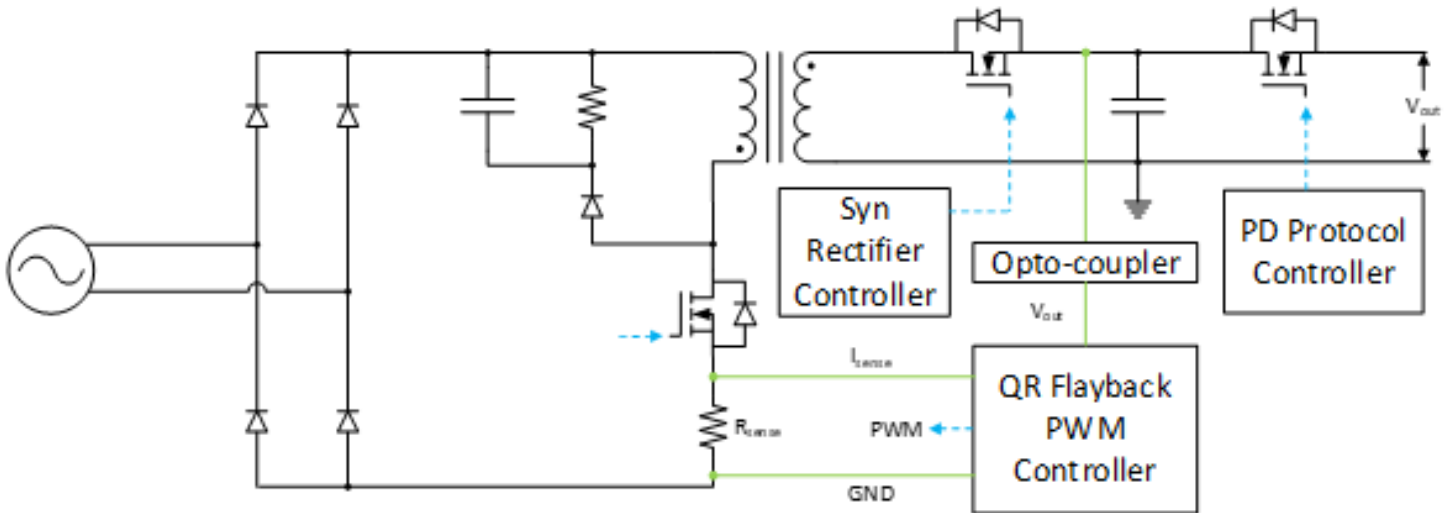

Figure 6. The sensed signals on the AZ-SiC-EVB-45W-FB evaluation board

4. Revision History

Major changes since last revision

Document version	Description of Change
1.0	Initial Version