

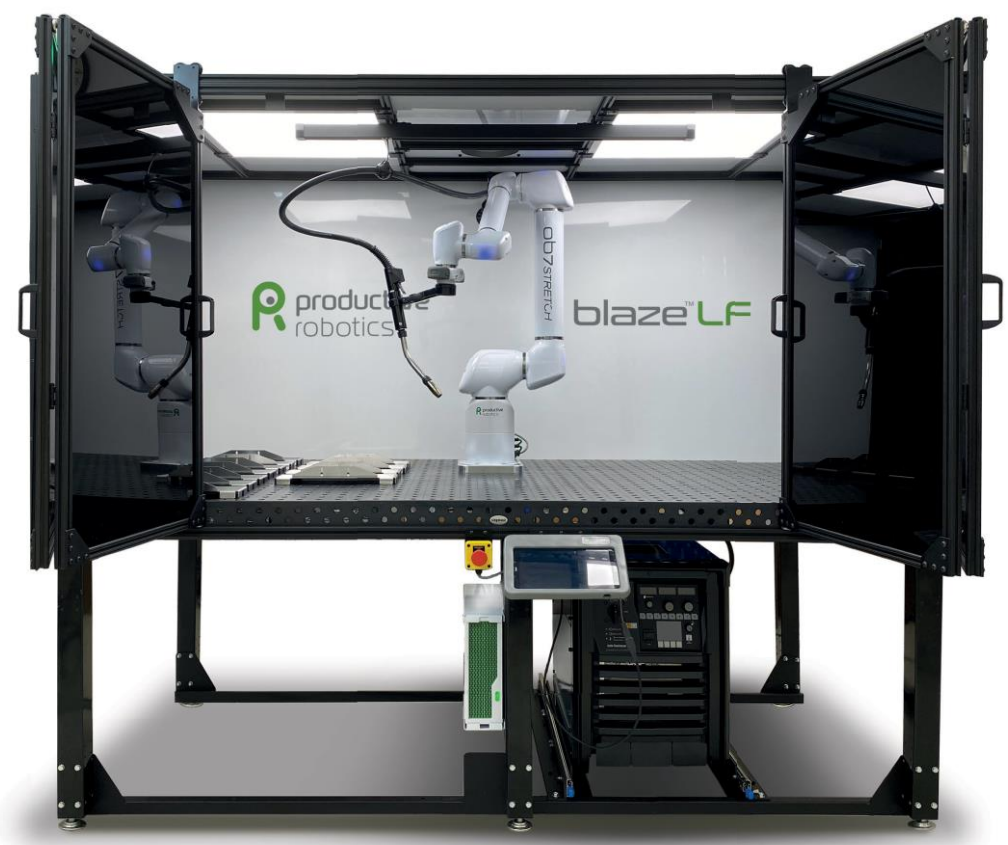

# blaze™ LF

Large Format Automated Robotic Welder  
*Perfect Welds Every Time*



### Dimensions

|                    |   |
|--------------------|---|
| Overall            | 98"w x 49"d x 80"h                        |
| Table Height       | 36"                                       |
| Weld Table         | 48"w x 96"d                               |
| <b>Gener</b>       |   |
| Lighting           | High intensity LED                        |
| Fume Extraction    | Built in, connects to your exhaust duct   |
| <b>OB7 Stretch</b> |   |
| Reach              | 1.3M                                      |
| Welding Modes      | Continuous, spot, stitch, weave           |
| Weld Recipes       | Unlimited                                 |
| Programming        | No Programming. Robot learns by teaching. |



### Auto Continuum 350 Welder

|                               |  |
|-------------------------------|--|
| Maximum Current               | 350 Amp 10V - 44V  |
| Power Supply                  | 230VAC, 380VAC, 400 VAC, 460Vac, 575Vac, 3 Phase 50/60hz |
| Duty Cycle                    | 100%   |
| <b>Advanced MIG processes</b> |  |
| Versa-Pulse™                  |  |
| Accu-Pulse® MIG (GMAW-P)      |  |
| RMD®                          |  |
| MIG (GMAW)                    |  |
| High-deposition MIG (GMAW)    |  |
| Flux-cored (FCAW)             |  |
| <b>Wire Drive</b>             |  |
| Welding Circuit Rating        | 500A continuous  |
| Wire Feed Speed               | 50-1000 IPM (1.27–25.4 m/min.)                           |
| Wire Dia range                | .035–.078 in. (0.9–2.0 mm)                               |

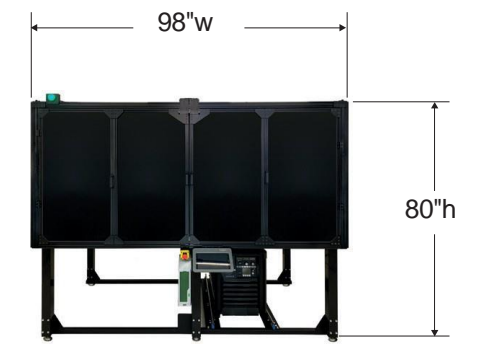

BORN  
IN THE  
USA





# blaze™ LF

Complete solution for large format automated welding.

## Weld Complexity Made Simple

The unlimited library of welding recipes allow complete control and customization of all welding parameters, including: material type, weld speed, wire speed, gas flow control, weld pattern and more. Simply select your desired recipe, or customize the recipe as you choose.

## Large Format Table

Large 4 ft x 8 ft welding table with unrestricted access allows multiple simultaneous weld fixture setups, or large weldments.

## Unrestricted Access

Full width front and side doors provide unrestricted access to the entire welding table.

## UNLIMITED Custom Weld Recipes

The unlimited library of welding recipes allow complete control and customization of all welding parameters, including: material type, weld speed, wire speed, gas flow control, weld pattern and more. Simply select your desired recipe, or customize the recipe as you choose.

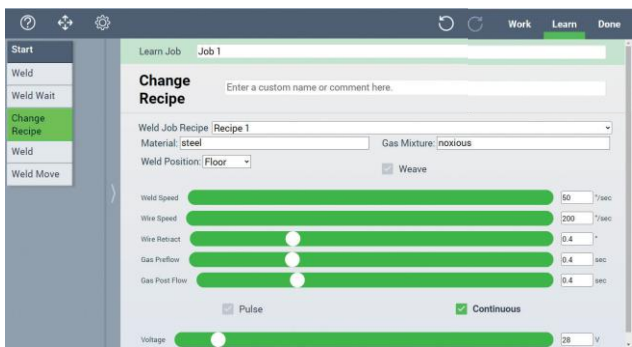

## OB7 Stretch Robot

OB7 Stretch robot provides unmatched reach and maneuverability that only a seven axis robot can provide.

## No Programming. Simple to Teach Without Special Skills.

Productive Robotics' famous "No Programming" system allows anyone, regardless of experience, to teach OB7 to weld.

## LED Lighting

Built in bright LED lighting provides perfect illumination for setting up jobs and fixtures.

## Auto Continuum 350 Welder

Top of the line welding package allows 100% duty cycle handles nearly any wire type with continuous welding without breaks or interruptions.

## Fume Extraction

Built in fume extraction fan connects to your exhaust ducting.

## Tablet Controller

All welding details and recipes set on the tablet with famous drag and drop display.

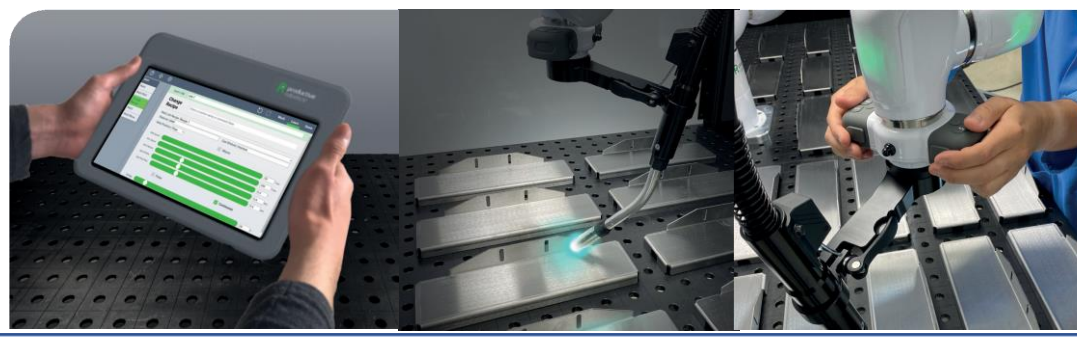





# blaze™ DUO

High Production Dual Station Robotic Welder  
*Perfect Welds Every Time*



## Dimensions

|                     |                                   |
|---------------------|-----------------------------------|
| Overall             | 101"w x 61"d x 100"h              |
| Table Height        | 36"                               |
| Two Weld Stations   | 41.75"w x 48"d                    |
| Spatter Catch Trays | 2 trays covering entire weld area |

## General

|                 |   |
|-----------------|---|
| Lighting        | High intensity LED                      |
| Fume Extraction | Built in, connects to your exhaust duct |

## OB7 Stretch

|               |   |
|---------------|---|
| Reach         | 1.3M                                      |
| Welding Modes | Continuous, spot, stitch, weave           |
| Weld Recipes  | Unlimited                                 |
| Programming   | No Programming. Robot learns by teaching. |



## Auto Continuum 350 Welder

|                 |  |
|-----------------|--|
| Maximum Current | 350 Amp 10V - 44V  |
| Power Supply    | 230VAC, 380VAC, 400 VAC, 460Vac, 575Vac, 3 Phase 50/60hz |
| Duty Cycle      | 100%   |

## Advanced MIG processes

|                          |  |
|--------------------------|--|
| Versa-Pulse™             |  |
| Accu-Pulse® MIG (GMAW-P) |  |
| RMD®                     |  |

|                            |  |
|----------------------------|--|
| MIG (GMAW)                 |  |
| High-deposition MIG (GMAW) |  |
| Flux-cored (FCAW)          |  |

|                        |                                |
|------------------------|--------------------------------|
| Wire Drive             |                                |
| Welding Circuit Rating | 500A continuous                |
| Wire Feed Speed        | 50-1000 IPM (1.27–25.4 m/min.) |
| Wire Dia range         | .035–.078 in. (0.9–2.0 mm)     |

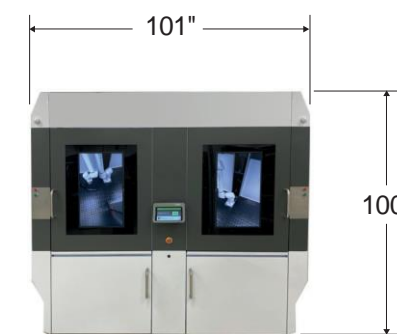

BORN  
IN THE  
USA



PURE PRECISION OEE LLC

Address – 7427 MATTHEWS MINT HILL RD STE 105-315 Mint Hill, NC, 28227-7862

Email – [ProductiveRobotics@PurePrecisionOEE.com](mailto:ProductiveRobotics@PurePrecisionOEE.com) Website – [PurePrecisionOEE.com](http://PurePrecisionOEE.com)

Phone – (704) 275-1214





# blaze™ DUO

All-in-one solution includes everything needed for high production automated welding.

## Two Stations for Simultaneous Setup and Welding

Automatic doors separate two identical weld stations allowing operator to be safely setting up one job while the robot is welding another.

## OB7 Stretch Robot

OB7 Stretch robot provides unmatched reach and maneuverability that only a seven axis robot can provide.

## No Programming. Simple to Teach Without Special Skills.

Famous "No Programming" system allows anyone, regardless of experience, to teach OB7 to weld.

## Auto Continuum 350 Welder

Top of the line welding package allows 100% duty cycle. Handles nearly any wire type with continuous welding, without breaks or interruptions.

## Filtered Fume Extraction

Unique combination of Merv 8 + Merv 14 filtering allow the Blaze system to operate in most any environment.

## Unrestricted Access

Double doors at each weld station open fully to allow complete and unrestricted access to the weld table and all setups.



## UNLIMITED Weld Complexity Made Simple

There is no limit to the complexity of a welding job. From simple to complex paths, varying weld recipes and weld types, the OB7 robot easily learns any job in minutes.

## LED Lighting

Built in bright LED lighting provides perfect illumination for setting up jobs and fixtures.



## BlazeVision™ Live Video Monitoring

Direct video monitoring of welding, in progress, displayed on the Blaze Vision monitor. Welding visors, goggles, or welding screens are not required.

## Spatter Catch Trays

Built in catch trays under table collect weld spatter.



## Tablet Controller

All welding details and recipes set on the tablet with famous drag and drop display.

## UNLIMITED Custom Weld Recipes

The unlimited library of welding recipes allow complete control and customization of all welding parameters, including: material type, weld speed, wire speed, gas flow control, weld pattern and more. Simply select your desired recipe, or customize the recipe as you choose.

