

Change	Description	Initials	Date
A	L1 OF 5300 MODEL CHANGED	SMG	9-22-20
B	L1 OF 3250 MODEL CHANGED	SMG	2-10-21
C	DIMENSION ADDED	SMG	8-9-21

REV. PART NO. **D27343-HLSUB54**

WELDING NOTES:
 1) ALL WELDS NOT SPECIFIED TO BE 1/4" FILLET
 2) ALL WELDS TO BE SOLID

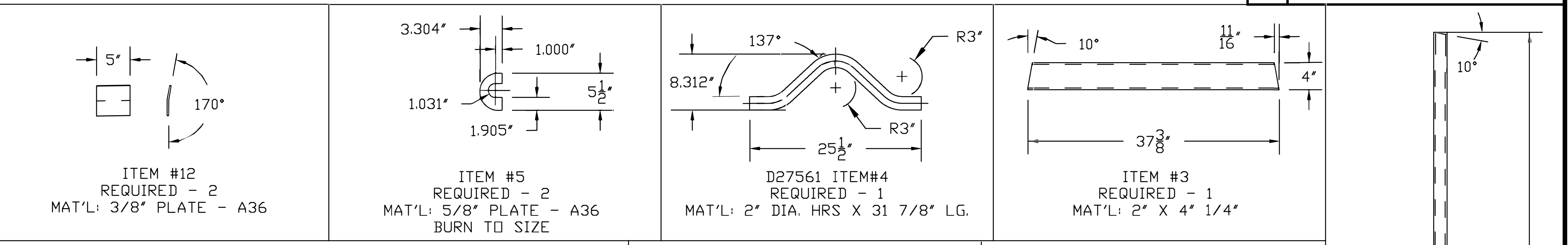

ITEM #10 TO BE WELDED INSIDE AND OUT AT ALL POINTS OF CONTACT

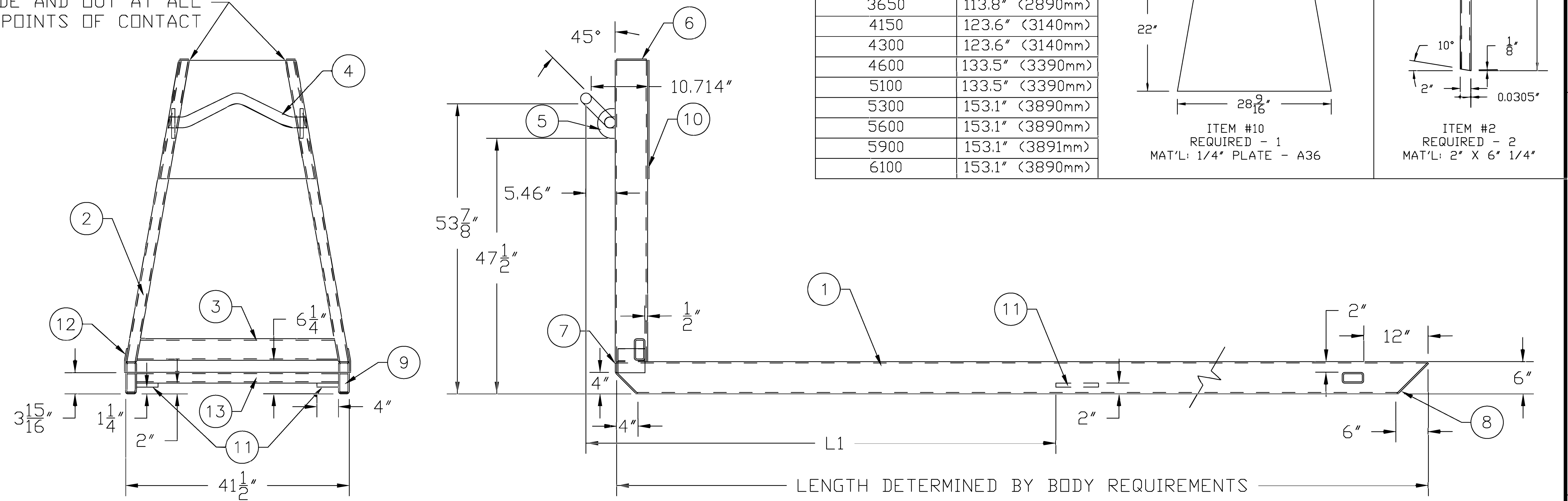

L1 LENGTH	
G-LENGTH	L1
3250	104.0" (2640mm)
3650	113.8" (2890mm)
4150	123.6" (3140mm)
4300	123.6" (3140mm)
4600	133.5" (3390mm)
5100	133.5" (3390mm)
5300	153.1" (3890mm)
5600	153.1" (3890mm)
5900	153.1" (3891mm)
6100	153.1" (3890mm)

ITEM#	QUAN.	DESCRIPTION/SIZE	PART NO.
13	1	RECT. TUBE - 2" X 4" X 1/4" X 37 1/2" LG.	
12	2	1/4" PLATE - A36	SEE DETAIL
11	2	3/4" X 4" X 8" - A36	
10	1	1/4" PLATE - A36	SEE DETAIL
9	2	END CAP - 1 1/2" X 5 3/8" X 1/4" - A36	
8	2	END CAP - 1 1/2" X 7 7/8" X 1/4" - A36	
7	2	END CAP - 1 1/2" X 1 3/4" X 1/4" - A36	
6	2	END CAP - 1 5/8" X 5 1/2" X 1/4" - A36	
5	2	5/8" PLATE - A36	SEE DETAIL
4	1	LIFT BAR - 2" DIA. HRS	D27343
3	1	REC. TUBE - 2" X 4" X 1/4"	SEE DETAIL
2	2	REC.TUBE - 2" X 6" X 1/4"	SEE DETAIL
1	2	MIN. REQ'D - REC.TUBE - 2" X 6" X 1/4"	SEE DWG

BREAK ALL SHARP EDGES
 PRIMED AND PAINTED BLACK

Cargotec Cargotec Inc. 12233 Williams Road Perrysburg, Ohio 43551 Tel (419) 482-6000 <small>Tolerance - unless otherwise noted. Tolerances are in inches</small> 2-PLACE ±.00..... .03 3-PLACE ±.000..... .015 ANGULAR ±1' FRACTIONAL ±1/16" Break all sharp corners unless otherwise specified.	THIS PROPERTY AND ALL INFORMATION THEREIN IS THE PROPERTY OF CARGOTEC, INC., 307 BROADWAY, SWANTON, OHIO 43558 AND IS CONFIDENTIAL. IT MUST NOT BE MADE PUBLIC OR COPIED. THIS DRAWING IS LOANED TO RETURN UPON DEMAND AND SHALL NOT BE USED DIRECTLY OR INDIRECTLY IN ANY WAY DETRIMENTAL TO OUR INTERESTS. OUR PRIOR SPECIFIC APPROVAL IS REQUIRED FOR EXPOSURE OF THIS DRAWING TO OTHERS FOR ANY PURPOSE.	Drawing Title: MULTILIFT
	Project Name: 54" HOOK HEIGHT BODY SUBFRAME	Next Assy. Dwg/Cad file no. D27343/HLSUB54