

# INSTALLATION INSTRUCTIONS

## MULTILIFT ULTIMA S/SL & Z/ZL Hooklift Base, Flex & Pro US edition



# Installation



Ultima Hooklift

01/2020

---

## Content

1 General	5
1.1 Suitability	5
1.2 Before starting the installation	5
1.3 General safety instructions for the installation work	5
2 Construction of Ultima Hooklift	6
2.1 Main components of steel construction S & SL	6
2.1 Main components of steel construction Z & ZL	7
2.2 Main components of hydraulic system S & SL	8
2.2 Main components of hydraulic system Z & ZL	9
2.3 Main components of control system	10
3 Installation of Ultima Hooklift	11
3.1 Safety precautions for the installation work	11
3.2 Levelling the chassis	12
3.3 Sub frame dimensions S & Z	13
3.4 Sub frame dimensions SL & ZL	14
3.5 Lifting hooklift onto the chassis	15
3.6 Releasing pressure from main cylinders	18
3.7 Installation plates	19
3.8 Installing additional cross member	22
3.9 Helping cylinder for tipping ULT26S70/78, ULT30S, ULT26Z	23
3.9.1 Helping cyl. hydraulics 26S70/78, 30S, 26Z FLEX & PRO	24
3.9.2 Helping cyl. hydraulics 26S70/78, 30S BASE	26
4 Hydraulic system	27
4.1 Safety precautions when installing hydraulic system	27
4.2 Specifications of the hydraulic system	27
4.3 Hydraulic connections ULTIMA BASE	29
4.4 Hydraulic connections ULTIMA FLEX & PRO	30
4.5 Hydraulic pump installation	31
4.6 Variable pump LS line installation	31
4.7 Oil tank	34
4.8 Hydraulic oil	37

5 PLC Control system	38
5.1 Installation of the control system	38
5.2 Installation of the control unit	40
5.3 Installation of the trailer tipping “high flow” ULT BASE	44
5.4 Installation of the pneumatic hook lock / safety latch	45
6 Accessories	46
6.1 Dashboard harness	46
6.2 Top seat control	47
6.3 External control	48
6.4 Stop button	49
6.5 Working lights	51
6.6 Rear view camera control connections	52
6.7 Connectivity gateway antenna	57
7 Testing the hooklift	59
7.1 Safety precautions when testing the hooklift	59
7.2 Testing the hooklift	59
8 Finishing the installation	61
9 User training	61

## 1. General

These Hooklift Installation Instructions will give the basic information on the installation of the hooklifts.

### 1.1 Suitability

These instructions are meant for the following Ultima Hooklifts S, SL, Z and ZL with Base, Flex or Pro control system.

### 1.2 Before starting the installation

Make sure that the Ultima Hooklift to be installed has been checked upon arrival for both transport damage and contents of the delivery including the kit box.

Check that all the parts are available to complete the installation as planned.

Check that the correct tools and proper lifting gear is available and in good condition.

Check the actual weight of the chassis by weighing it.

Check that the axle weight distribution calculation (TrailerWin) for correct positioning on the chassis and installation drawings are available.

Check that the truck manufacturer's installation instructions are available.

### 1.3 General safety instructions for the installation work

Ultima Hooklift may only be installed by qualified and trained personnel.

Ultima Hooklift can be installed only on suitable truck chassis which is designed for hooklift (or tipper) use and is allowed to carry the maximum load of the hooklift.

**We very strongly recommend that the truck is equipped with as stiff as possible stabilizers (sway bars) on all axles. A closed rear cross beam should be fitted as well!**

For further information please refer to your local Multilift dealer.

Always use personal protective equipment and other safety means during the installation work and while testing the hooklift.

Due to continuous development some of the illustration may look different to the one used in the hooklift.

Cargotec Finland Oy reserves all rights for this manual.

Cargotec Finland Oy  
Raisio  
2020

## 2. Construction of ULTIMA Hooklift

### 2.1 Main components of steel construction S & SL

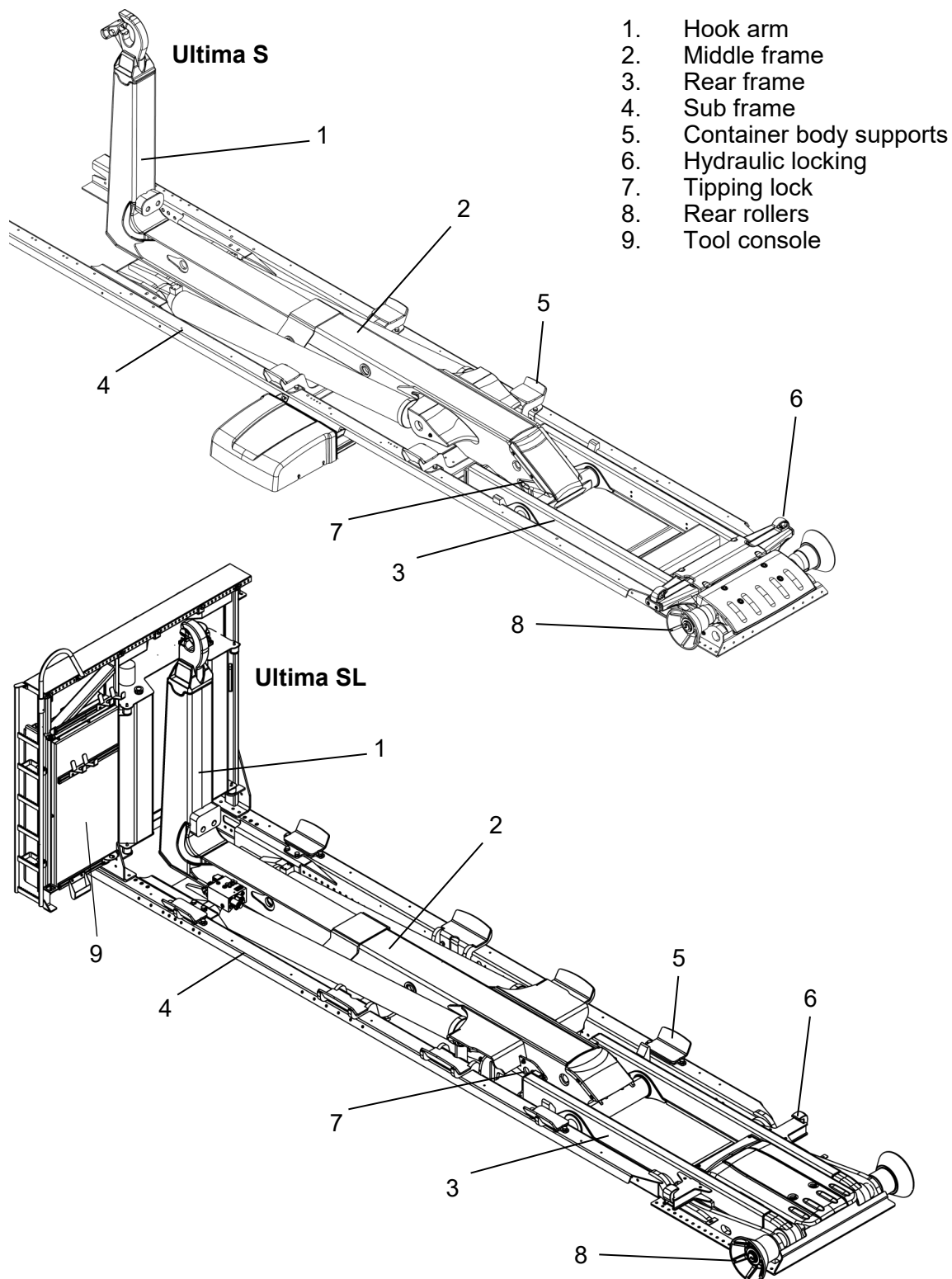

## 2. Construction of ULTIMA Hooklift

### 2.1 Main components of steel construction Z & ZL

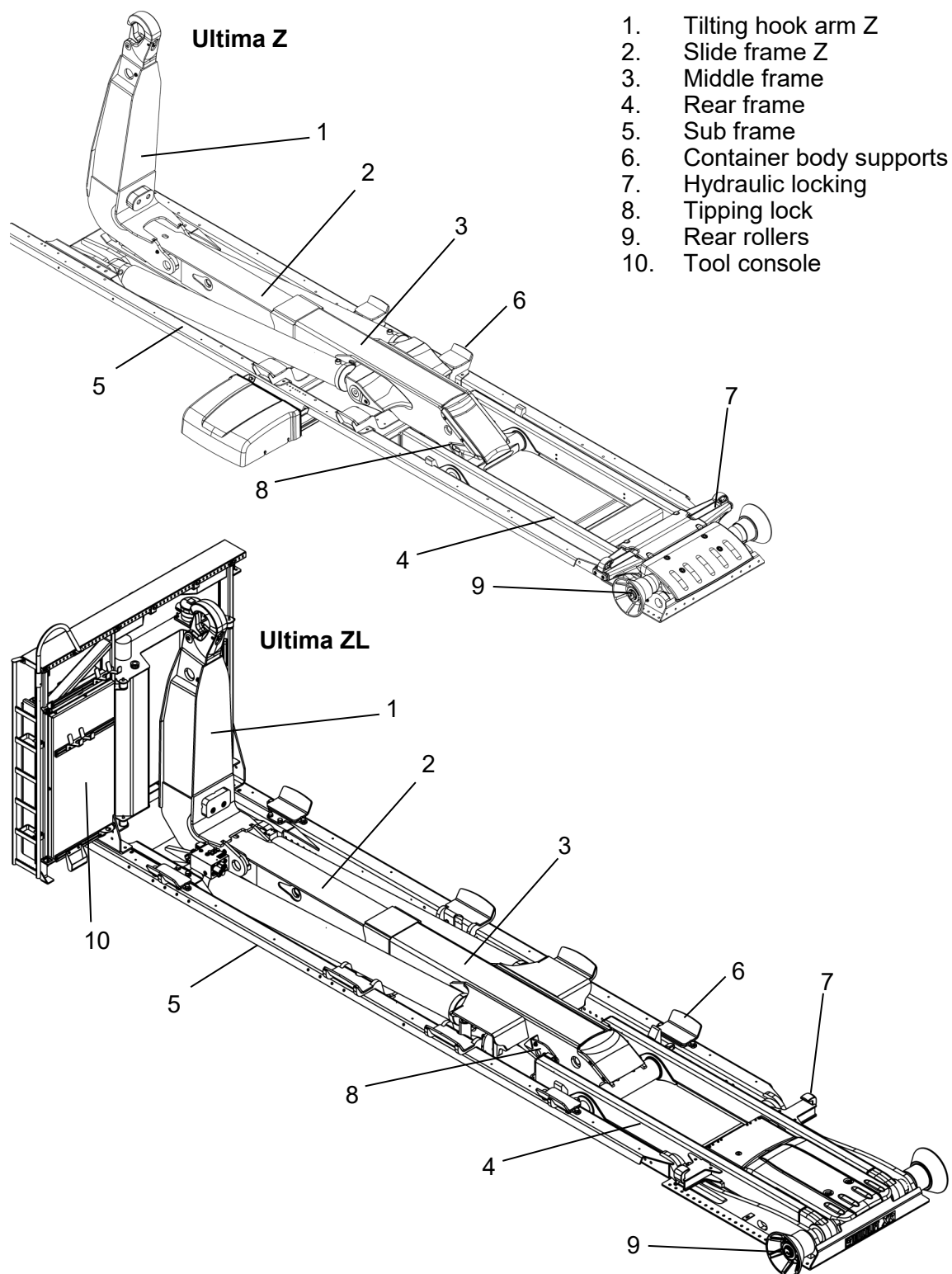

## 2.2 Main components of hydraulic system S & SL

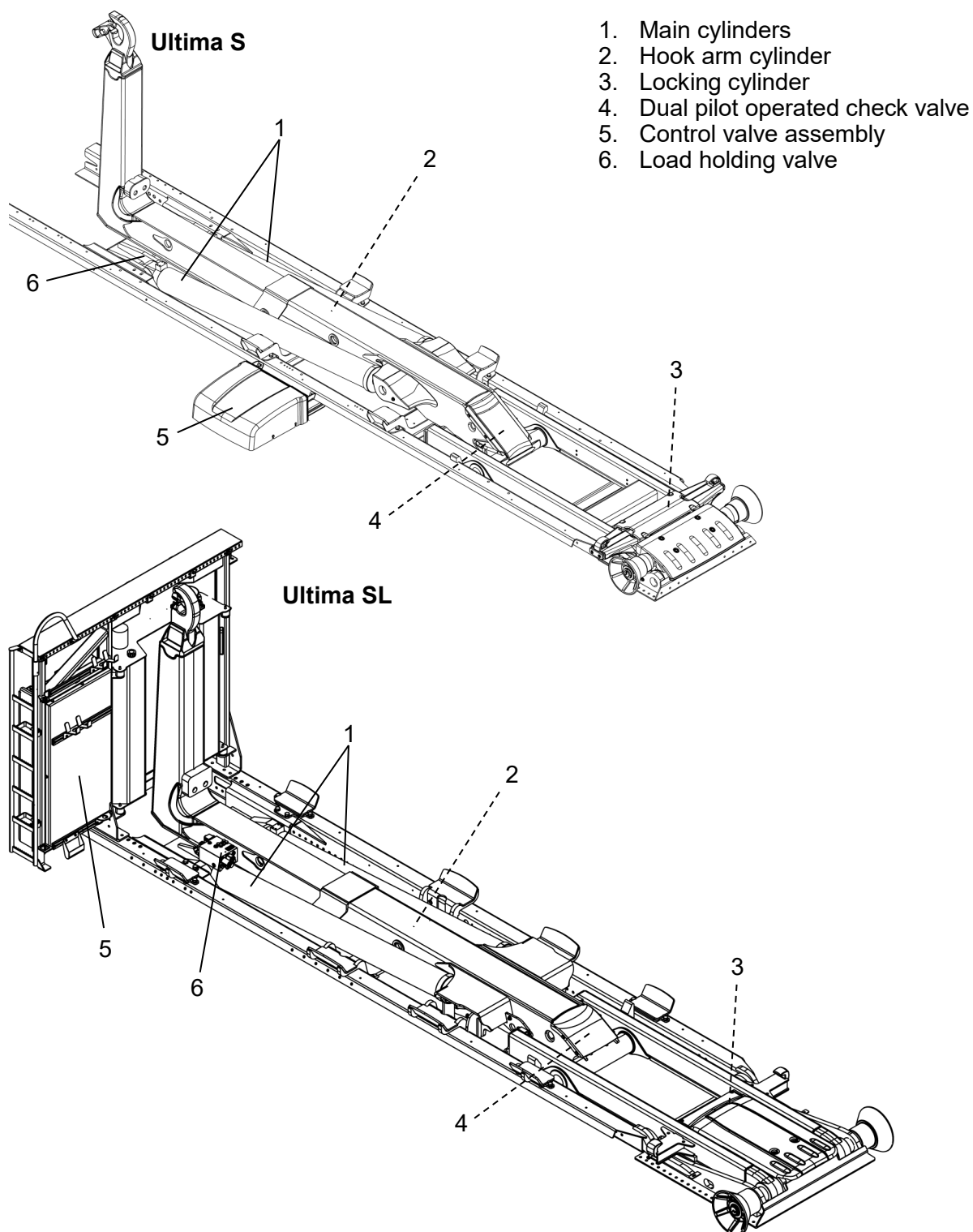



## 2.2 Main components of hydraulic system Z & ZL

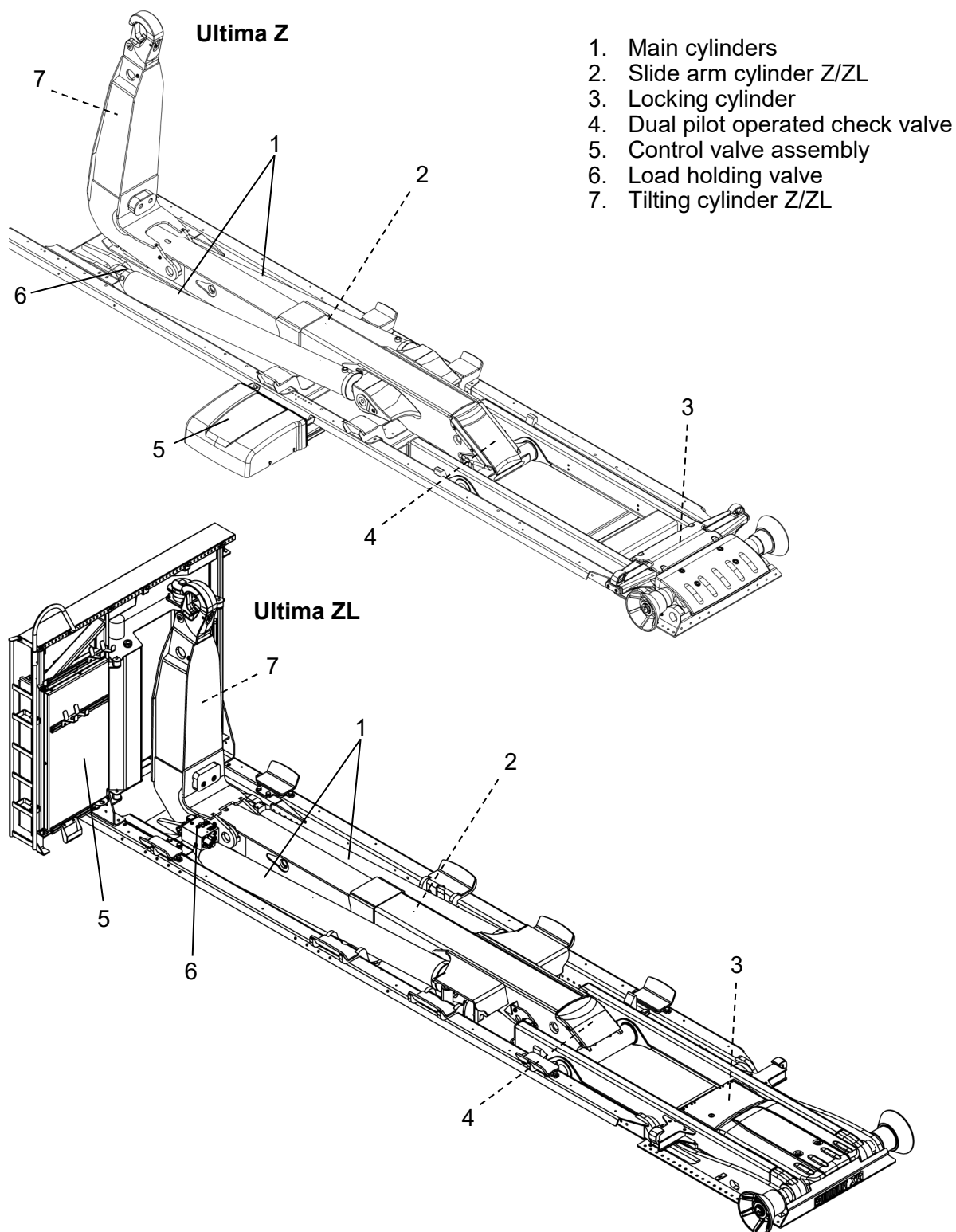

## 2.3 Main components of control system

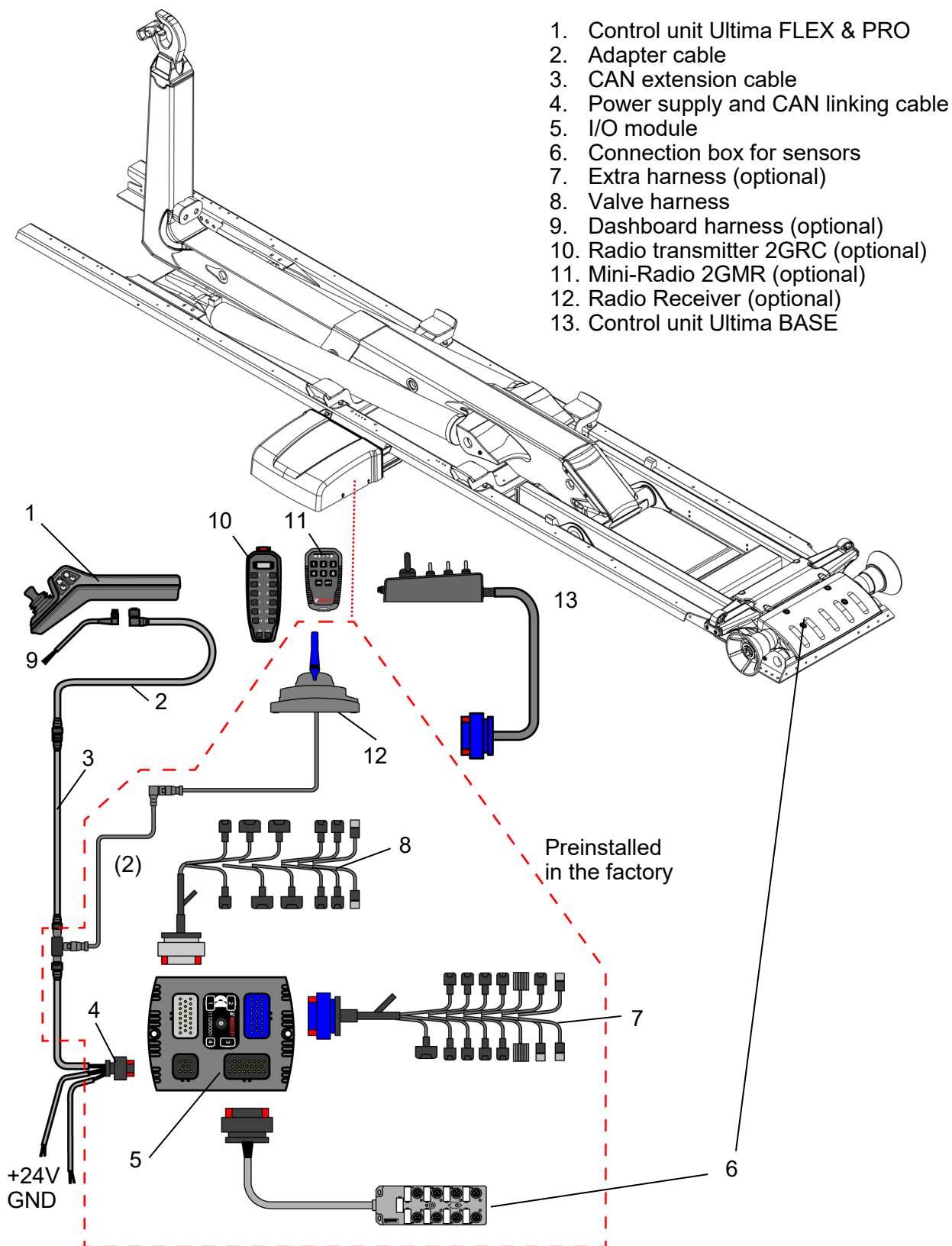

## 3. Installation of Ultima Hooklift

### 3.1 Safety precautions for the installation work

Before the installation and any welding work is done, make sure that the battery cables of the truck's electric system are detached or protected according to the truck manufacturer's instructions. Also check other possible protection needed for the electric and electronic systems. **The 8-pin connector of the hooklift power supply on the I/O module must be detached before welding.**

To prevent fire, make sure before welding, flame cutting and grinding that sparks can not fly onto oil or fuel etc. in or around the assembly

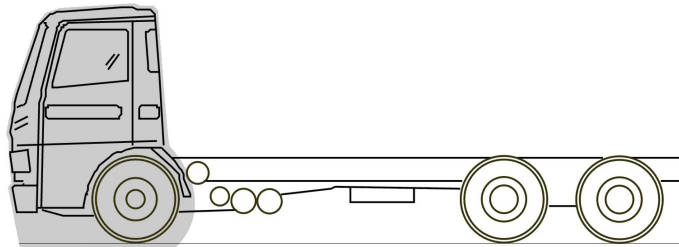

The truck cabin must be protected well before any installation work. The cabin must always be fully tilted (if applicable) up to the mechanical lock before work is carried under it. Check the truck manufacturer's instructions for tilting the cabin.

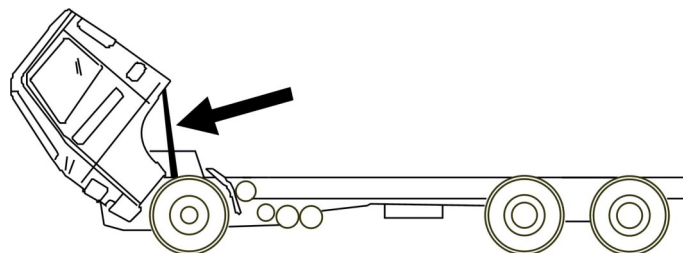

Before lifting the hooklift check the operation and condition of the lifting equipment, the lifting hooks and wires, ropes or hoisting belts. Check the lifting capacity of the lifting equipment is adequate to the weight of the hooklift and that lifting can be done safely. See 3.5 Lifting of hooklift.

## 3.2 Levelling the chassis

It is essential for the quality and correct installation of the hooklift that the chassis is in a completely level position during the installation.

Make sure that:

- The truck chassis is horizontal across its width; use a level to check it.
- Both chassis beams are aligned.
- All wheels are straight forward.
- Tire pressures are correct.
- Lift axles and bogie are down; all wheels must be firm on ground.
- There is no hole or drain cover under any wheel.

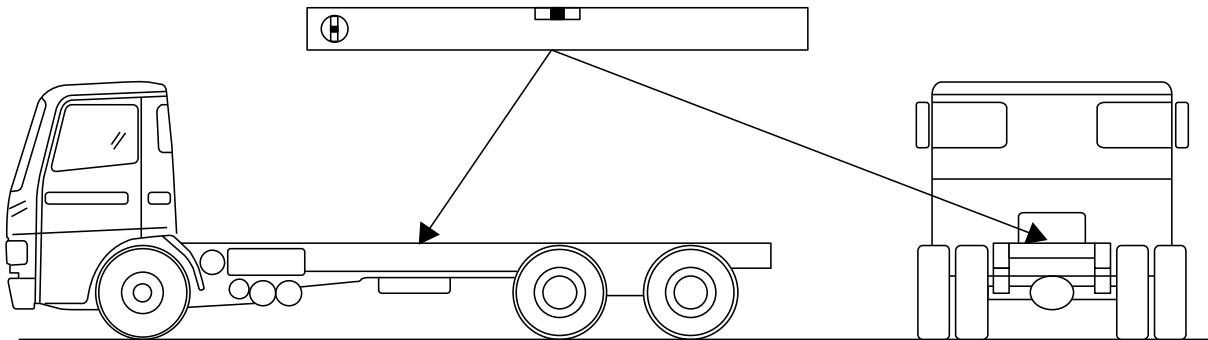

For levelling an air-suspension axles the air bags must be deflated and the rear end must be supported.

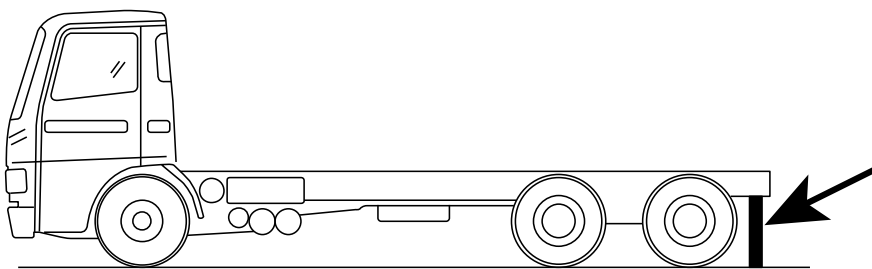

Remember to level that chassis each time the vehicle is moved.

### 3.3 Sub frame dimensions S & Z

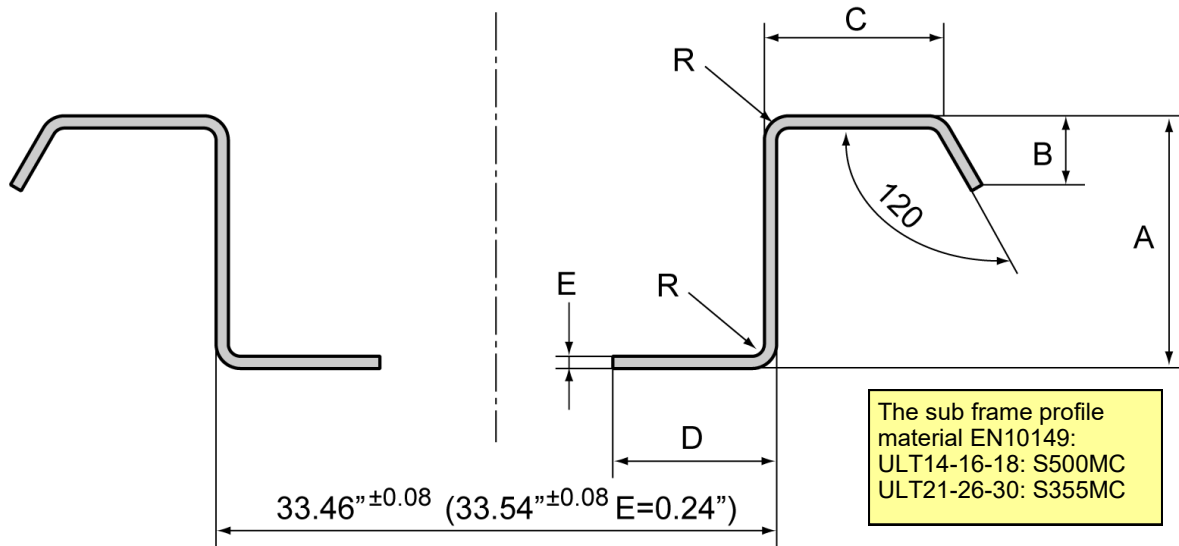

Hooklift type	A (in)	B (in)	C (in)	D (in)	E (in)	R (in)
ULT14S ULT16S46-56	5.71	1.85	4.45	4.21	0.2	0.2
ULT16S55, 59-61 ULT18S/Z	5.71	1.89	4.45	4.21	0.24	0.24
ULT21S/Z ULT24S, ULT26Z	6.5	1.93	4.76	4.21	0.31	0.31
ULT26S ULT30S	6.5	1.93	4.76	4.21	0.31	0.31

The values in the next table are calculated with both side Z-beams and standard amount of cross members when the beams are working together. If the value is needed only for one beam, then the value can be halved.

Hooklift type	A sub frame (in <sup>2</sup> )	W <sub>x</sub> top flange (in <sup>3</sup> )	e top flange (in)	W <sub>x</sub> bottom fl. (in <sup>3</sup> )	e bottom fl. (in)	I <sub>x</sub> (in <sup>4</sup> )
ULT14S ULT16S46-56	5.9226	12.5773	2.64	10.1166	-3.07	32.0071
ULT16S55, 59-61 ULT18S/Z	7.3331	14.6526	2.64	12.2196	-3.07	38.0368
ULT21S/Z ULT24S, ULT26Z	9.7588	22.4813	2.87	14.8327	-3.62	64.6000
ULT26S ULT30S	10.6144	26.1114	3.31	21.5104	-3.98	85.9036

### 3.4 The sub frame dimensions SL & ZL

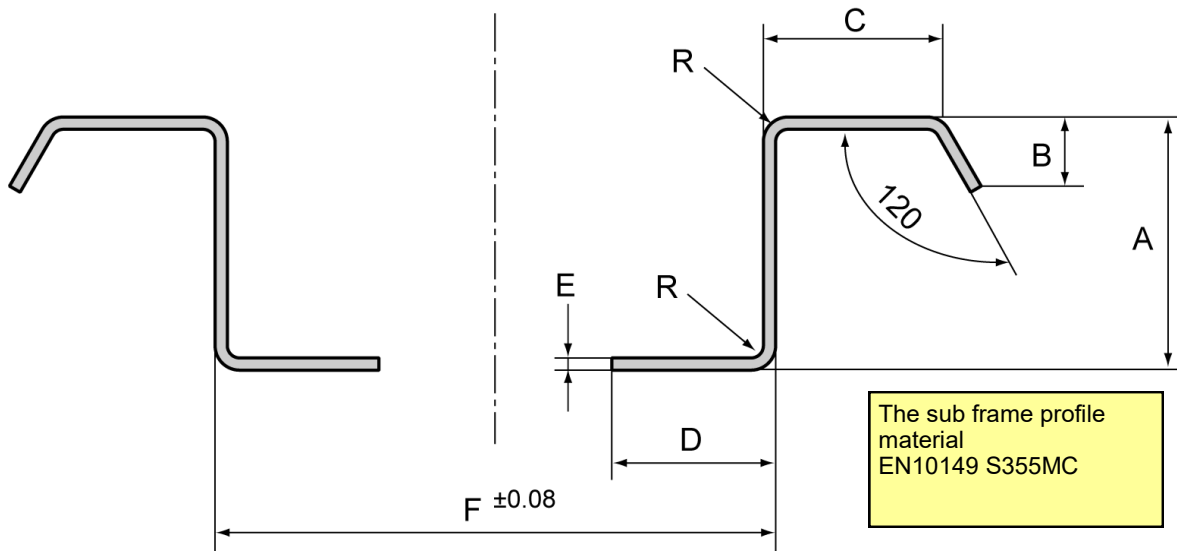

Hooklift type	A (in)	B (in)	C (in)	D (in)	E (in)	F (in)	R (in)
ULT18 / 21SL	6.5	1.93	4.57	4.21	0.24	33.31	0.24
ULT22 / 24 / 26SL ULT20 / 24ZL	6.5	1.93	4.57	4.21	0.31	33.46	0.31

The values in the next table are calculated with both side Z-beams and standard amount of cross members when the beams are working together. If the value is needed only for one beam, then the value can be halved.

Hooklift type	A <sub>subframe</sub> (in <sup>2</sup> )	W <sub>x</sub> top flange (in <sup>3</sup> )	e top flange (in)	W <sub>x</sub> bottom fl. (in <sup>3</sup> )	e bottom fl. (in)	I <sub>x</sub> (in <sup>4</sup> )
ULT18 / 21SL	7.4323	17.6893	2.83	13.8176	-3.66	50.3950
ULT22 / 24 / 26SL ULT20 / 24ZL	9.7588	22.4813	2.87	17.8327	-3.62	64.6000

### 3.5 Lifting the hooklift onto the chassis

The hooklift must be lifted with an extra care to avoid any damages during the lifting. The hooklift can be ordered with pre-installed lifting lugs (MU111553501), with what the lifting can be done safe. Check that the lifting hooks of lifting chains will fit into the lifting lugs.

If the lifting lugs are not available, then the hooklift can be lifted from the body supports and rear rollers. Lifting from the hook arm, the middle frame or the rear frame is not allowed due to the risk of damages. Before lifting check to be sure that no hydraulic or electric components can be damaged.

The centre of gravity of the hooklift is approx. 55% of the G-length measured from rear rollers towards front.

Always check the condition and operation of the lifting equipment, hooks, ropes, wires and belts before lifting.

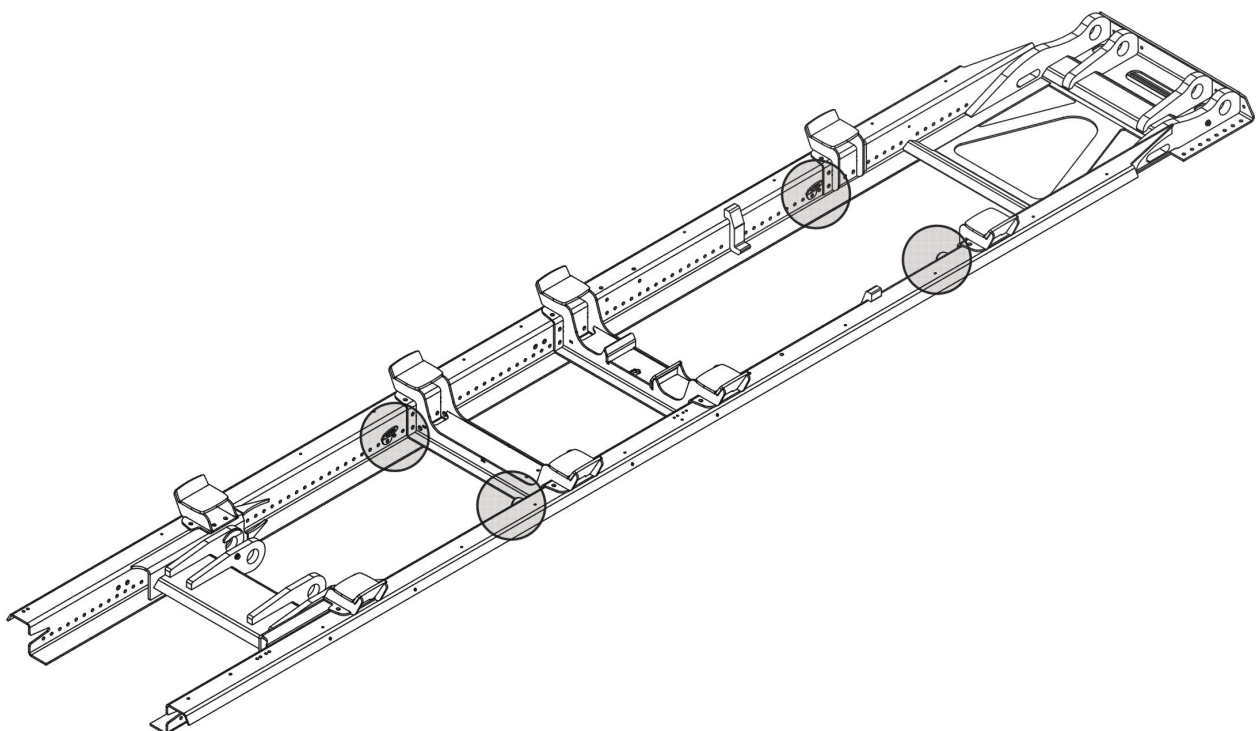
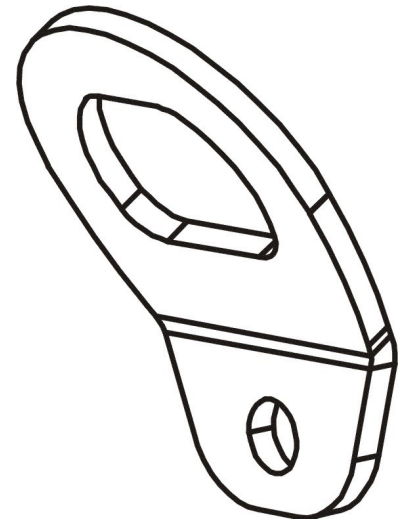

The weight of Ultima hooklifts can be seen in the table next page.

Remove the lifting lugs after the hooklift is lowered on the chassis.

# Installation



Ultima Hooklift

01/2020

The weight of Ultima hooklift includes hydraulic locking but not the oil tank.

Hooklift type	Weight (lbs)
ULT14S41	3527
ULT14S43	3593
ULT14S46	3660
ULT14S51	3880
ULT14S53	4056
ULT14S56	4101
ULT16S46	3836
ULT16S51	4056
ULT16S53	4233
ULT16S55/56	4277
ULT16S59	4387
ULT16S61	4431
ULT18S46	3902
ULT18S51	4123
ULT18S53	4321
ULT18S56	4409
ULT18S59	4453
ULT18S61	4497
ULT21S46	5049
ULT21S51	5247
ULT21S53	5445
ULT21S56	5511
ULT21S59	5578
ULT21S61	5622
ULT21S63	5710
ULT24S55	5556
ULT26S51	5622
ULT26S53	5842
ULT26S55/56	5908
ULT26S59	6019
ULT26S61	6063

Hooklift type	Weight (lbs)
ULT26S63	6151
ULT26S70	6790
ULT26S78	7121
ULT30S53	6107
ULT30S56	6151
ULT30S59	6283
ULT30S61	6327
ULT30S63	6415
ULT18Z46	5026
ULT18Z51	5203
ULT18Z53	5313
ULT18Z56	5423
ULT18Z59	5556
ULT18Z61	5732
ULT21Z51	5930
ULT21Z53	5996
ULT21Z56	6107
ULT21Z59	6195
ULT21Z61	6261
ULT26Z51	5996
ULT26Z53	6063
ULT26Z56	6173
ULT26Z59	6261
ULT26Z61	6327
ULT26Z65	6504



# Installation



Ultima Hooklift

01/2020

The weight includes hydraulic locking but not the oil tank.

NOTE! The tool console in front of the hooklift is increasing the total weight approx. 265 lb and moves the center of gravity more forward.

Hooklift type	Weight (lbs)
ULT18SL49	4453
ULT18SL51	4586
ULT18SL52	4696
ULT18SL53	4806
ULT18SL56	4850
ULT21SL49	4497
ULT21SL51	4630
ULT21SL52	4740
ULT21SL53	4850
ULT21SL56	4894
ULT22SL53	5302
ULT22SL56	5346
ULT22SL58	5456
ULT22SL59	5456
ULT22SL61	5478
ULT24SL56	5467
ULT24SL58	5600
ULT24SL59	5600
ULT24SL61	5622
ULT26SL56	5511
ULT26SL58	5644

Hooklift type	Weight (lbs)
ULT20ZL53	5688
ULT20ZL56	5842
ULT20ZL58	5930
ULT20ZL59	5930
ULT24ZL56	6019
ULT24ZL58	6129
ULT24ZL59	6129

### 3.6 Releasing pressure from main cylinders

There can be some oil pressure in main cylinders that might slightly bend the subframe of the hooklift. Before the mounting plates are installed the pressure must be released. This is done by feeding +24V power to the floating valve solenoid 122 on left side main cylinder. Use adapter cable MU113937001.

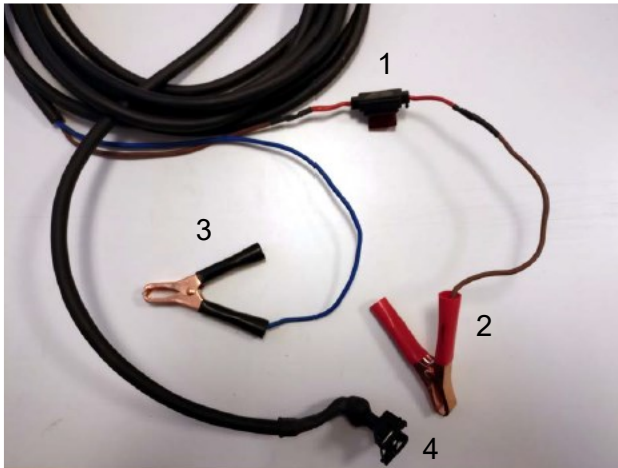

1. Fuse holder with 5A fuse
2. Battery clamp +24VDC
3. Battery clamp GND
4. Connector 122 for floating valve

Version without fast speed

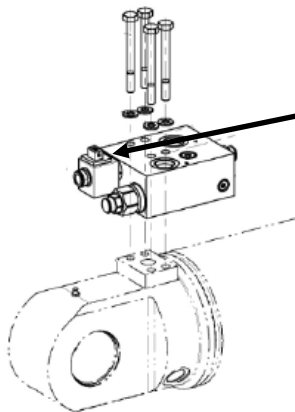

Version with fast speed

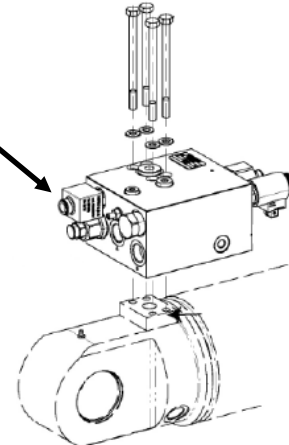

FLOATING 122

If the hooklift is not equipped with preinstalled oil reservoir, then open the plug from the tank line connector on the control valve before activating the solenoid and catch up the oil (max. 1 pt).

If the hooklift is equipped with preinstalled oil reservoir, the tank connector does not need to be opened.

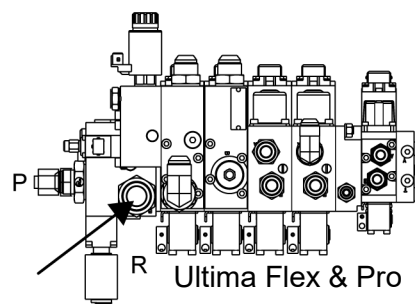
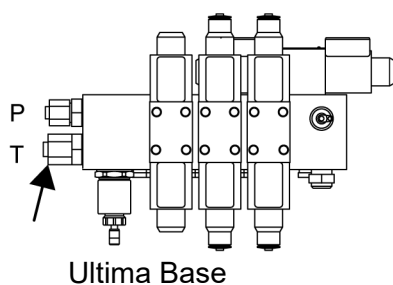

## 3.7 Installation plates

The installation plate kits are available to various truck chassis models. The standard kit is meant to hooklift lengths max 59. For the longer hooklifts additional plate kits are available and they usually follow the hooklift delivery.

The installation plate kit contains the flexible brackets 2-4 pairs for the front part of the hooklift and the fixed plates for the middle and rear part of the hooklift.

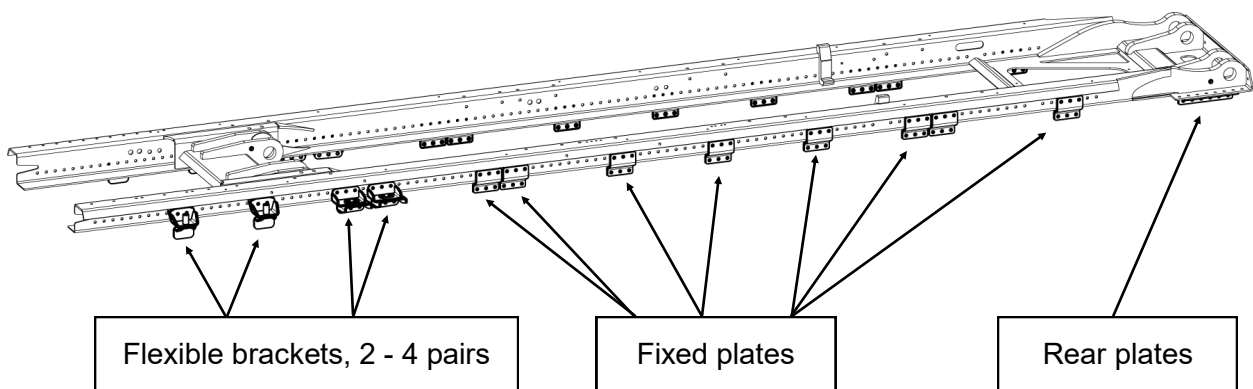

The predrilled holes in the truck chassis must be utilized, whenever possible.

The flexible brackets are installed to both sides of front cross member. The tightening torque of the vertical M16 8.8 bolts is 22 ft-lb - ¼ turns. Some truck manufacturers are requesting to use Belleville springs with vertical bolts in heavy conditions. Check truck manufacturer's instructions.

**NOTE!** If the hooklift is equipped with front locking then there must be fixed installation plates underneath the lock.

First installation plates towards the rear from flexible brackets must be large plates or doubled smaller plates. The large plates are necessary also under the middle frame / rear frame shaft.

When mounting the smaller plates the distance between the plates must be equal. The maximum distance of 43 ft must not be exceeded.

The rear beam is fastened to chassis with 6 x M14 (M16) fastening bolts on both sides.

Some truck manufacturers request M16 chassis fastener bolts (e.g. MB). Check the truck manufacturer's instructions.

# Installation



Ultima Hooklift

01/2020

## Examples of flexible brackets

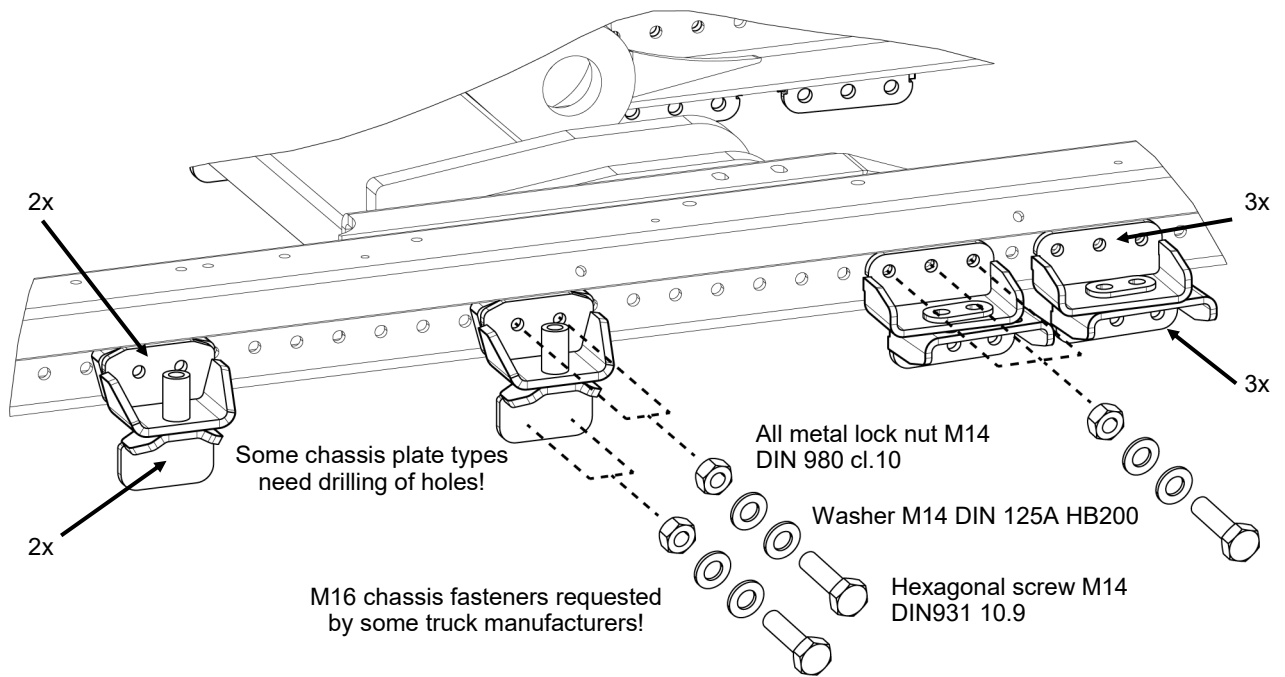

Tightening torque for M14 bolt is 125 ft-lb  
Tightening torque for M16 bolt is 203 ft-lb

Hexagonal screw M16 x 110 DIN931 8.8  
Tightening torque 22 ft-lb - 1/4 rev.

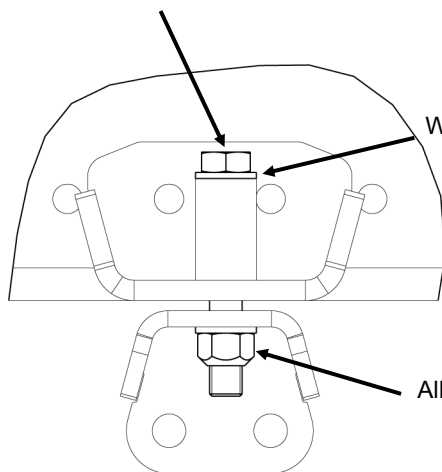

Hexagonal screw M16 x 60 DIN931 10.9  
Tightening torque 203 ft-lb

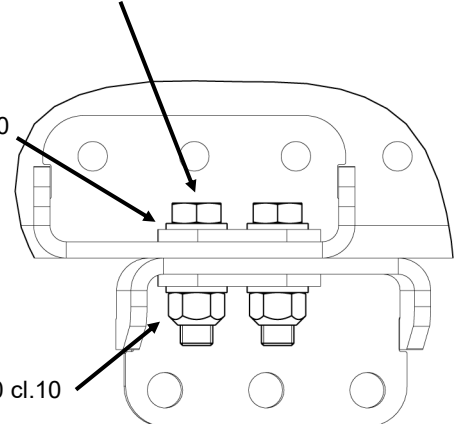

# Installation



Ultima Hooklift

01/2020

## Examples of fixed plates

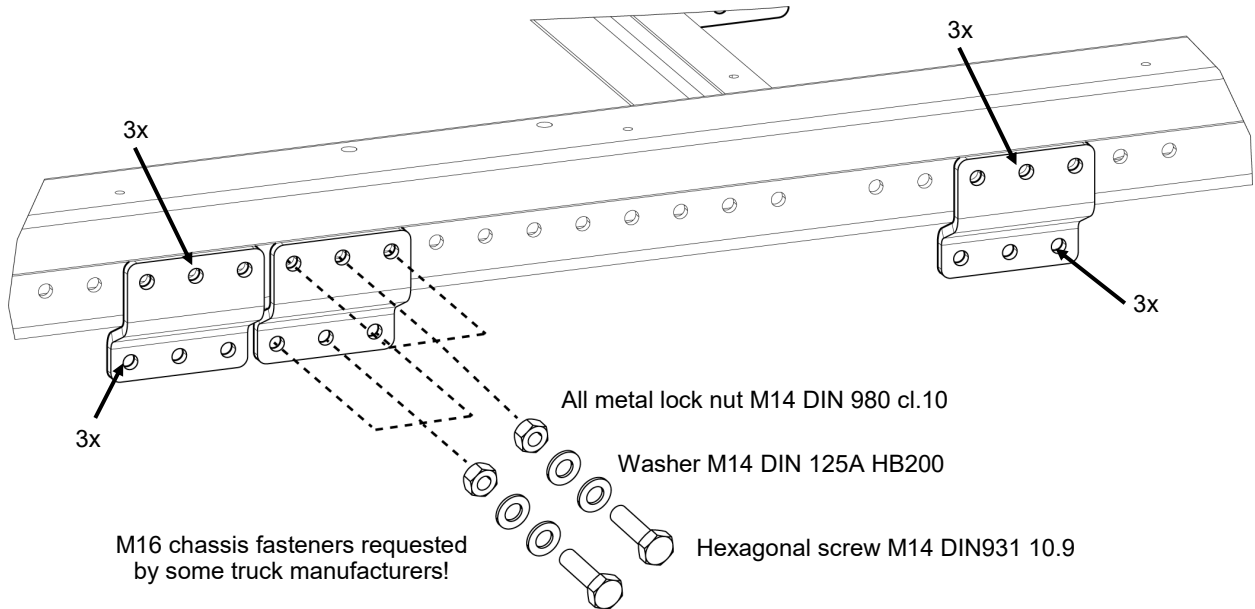

Tightening torque for M14 bolt is 125 ft-lb  
Tightening torque for M16 bolt is 203 ft-lb

## Example of rear plates

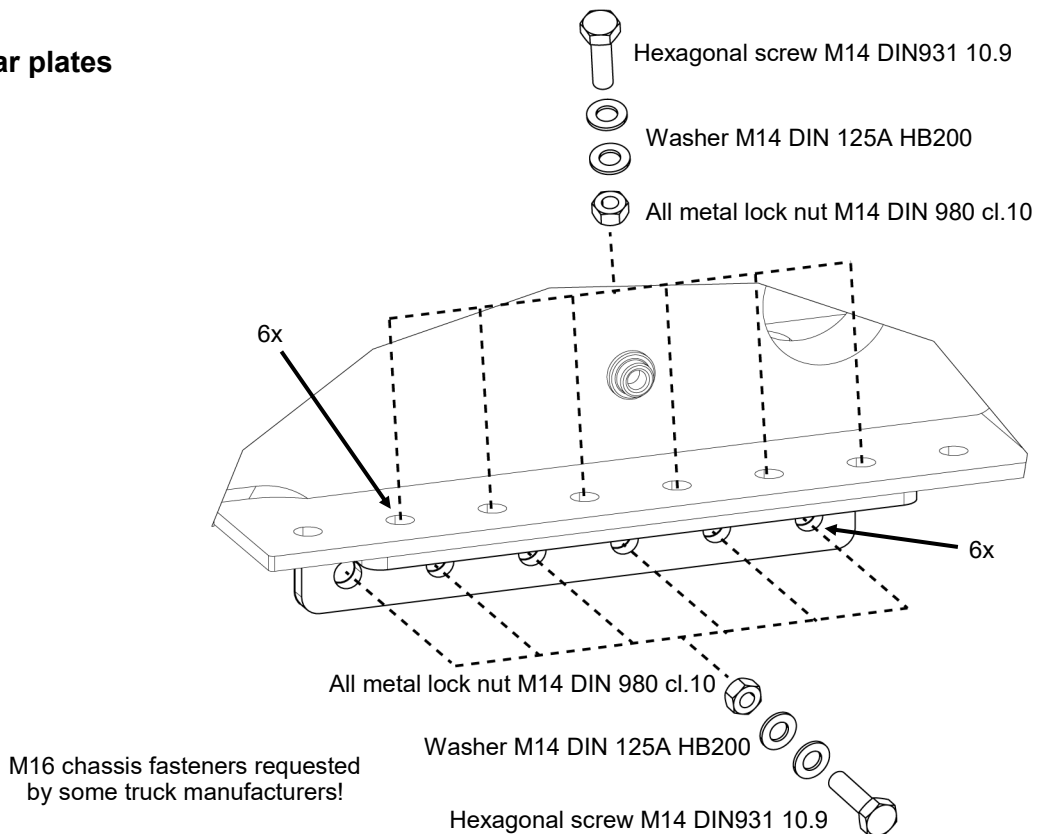

## 3.8 Installing the additional cross beam

An additional light crossbeam MU113760101 may be used in case subframe front side needs additional support.

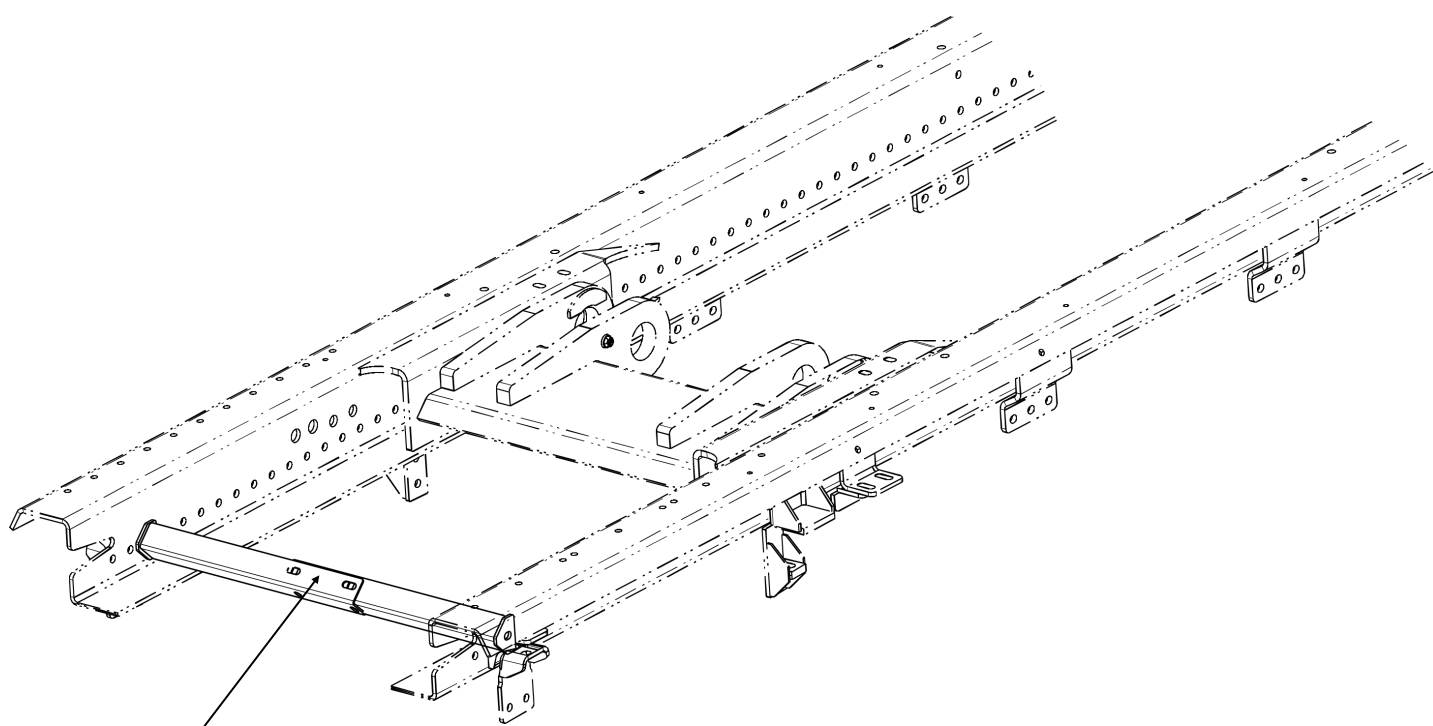

Install the cross beam with  
the first flexible bracket

### 3.9 Helping cylinder for tipping in ULT26S70/78, ULT30S and ULT26Z

The helping cylinder beam is delivered loose in the installation kit and it should be installed to the subframe in the area between the middle body support beams shown in the picture below. Check that the structural parts in the truck chassis allow free installation and that the hydraulic pipes or connectors under main cylinders do not hit the beam. The beam is fastened to the subframe with the M14x40 10.9 bolts included in the kit. The tightening torque is 88.5 ft-lb. In the beam there are alternative holes to move the cylinder about 2" sideways.

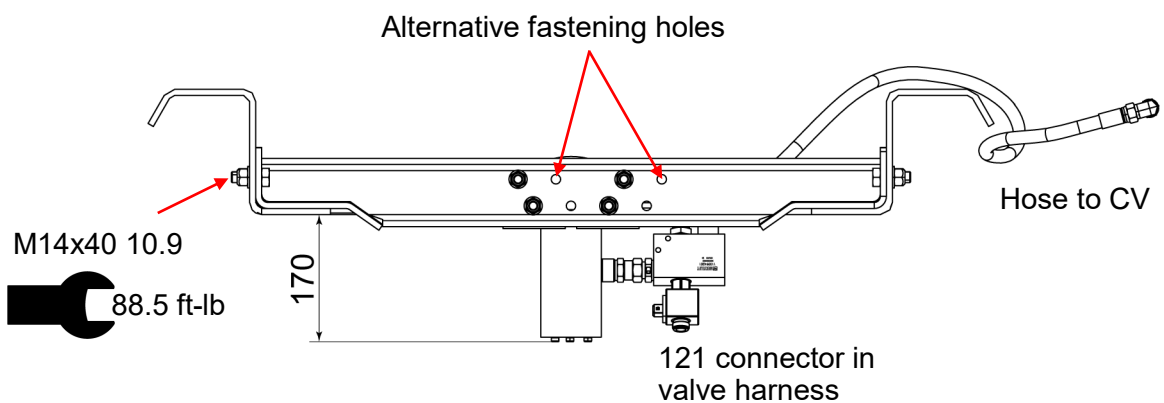
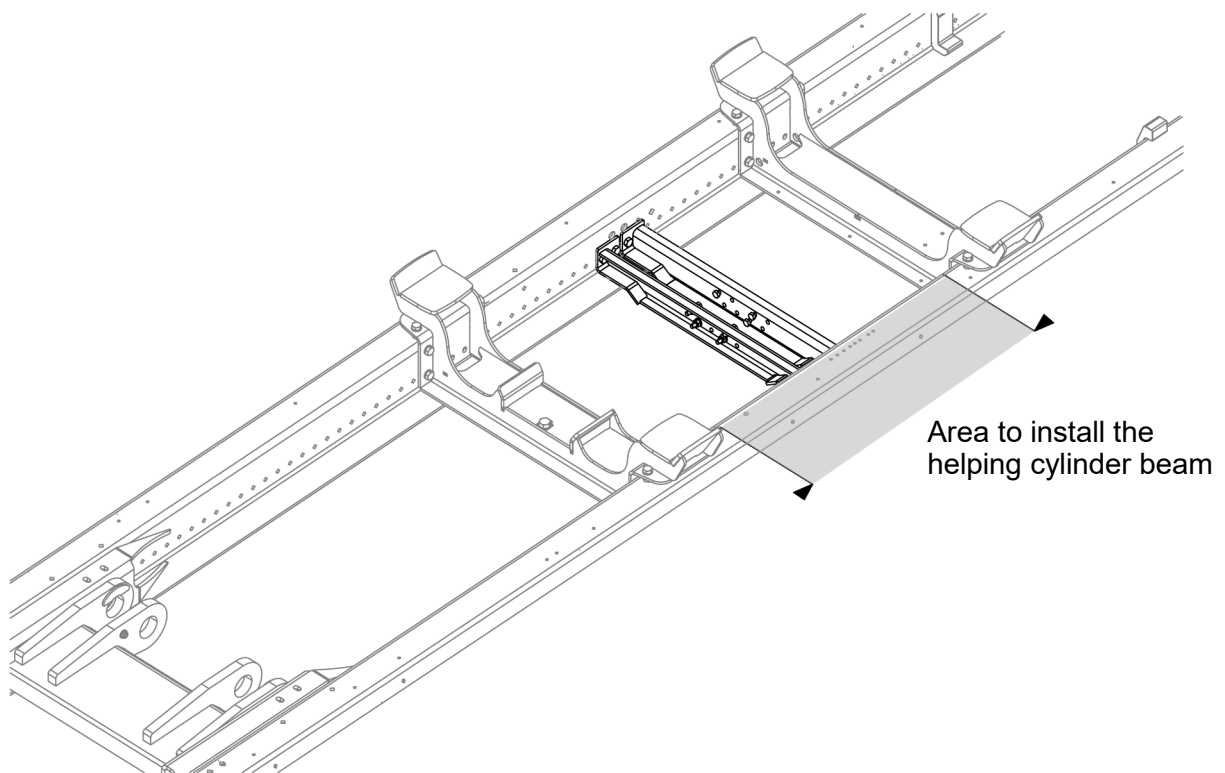

### 3.9.1 Hydraulic connections of helping cylinder in ULT26S70/78, ULT30S and ULT26Z Ultima Flex & Pro

After installation of the helping cylinder cross member connect the pressure hose in the side of the control valve to the elbow connector. Remove the plug from the connector and connect the hose. The tightening torque is 51.6 ft-lb.

The electric connector 121 for the solenoid valve is located near the control valve.

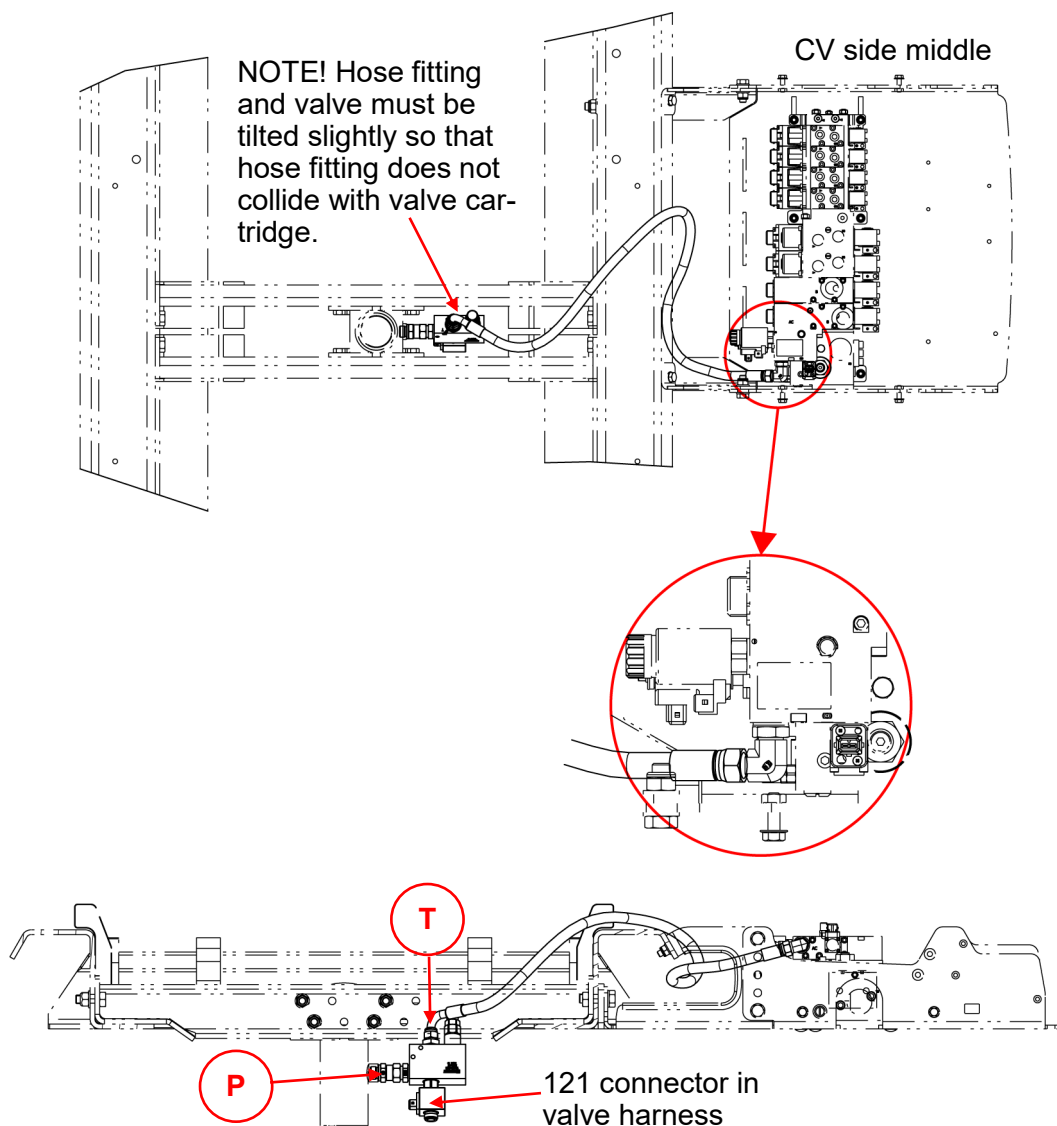

**NOTE! Valve must be assembled according to drawing. Wrong assembly can cause severe material damages!**



# Installation



Ultima Hooklift

01/2020

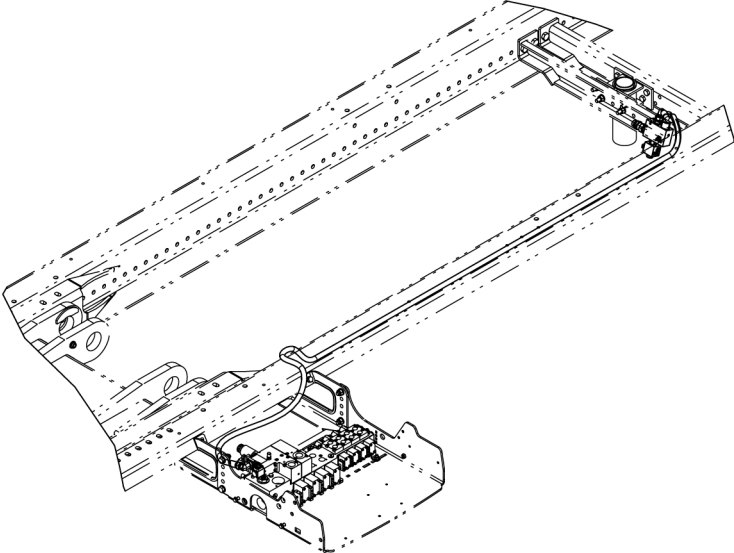

CV side front

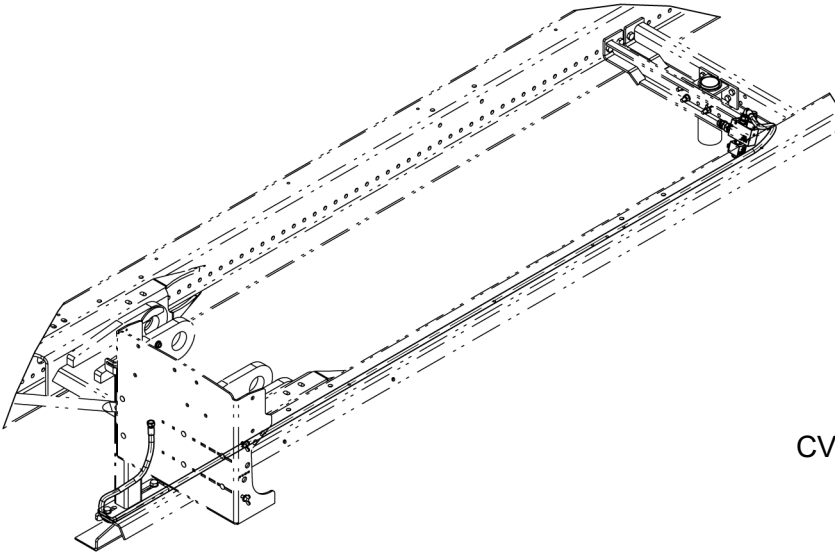

CV front corner

110035403  
Male stud connector

110035503  
Swivel male stud

110035405  
Male stud connector

113394201  
2-way solenoid valve NO  
dual check with PRV 4351 psi

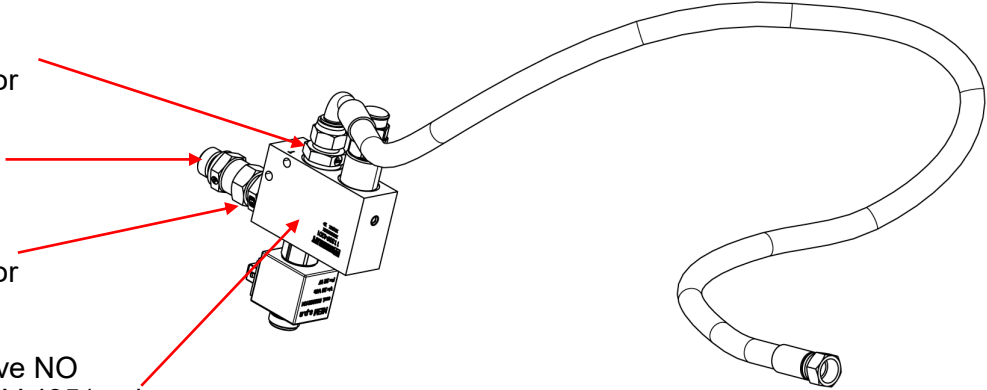

## 3.9.2 Hydraulic connections of helping cylinder in ULT26S70/78 and ULT30S BASE

After installation of the helping cylinder cross member connect the pressure hose to the piston side line of the main cylinders. There is a plugged T-connector behind the control valve for this connection. Remove the plug and connect the hose. The tightening torque is 51.6 ft-lb.

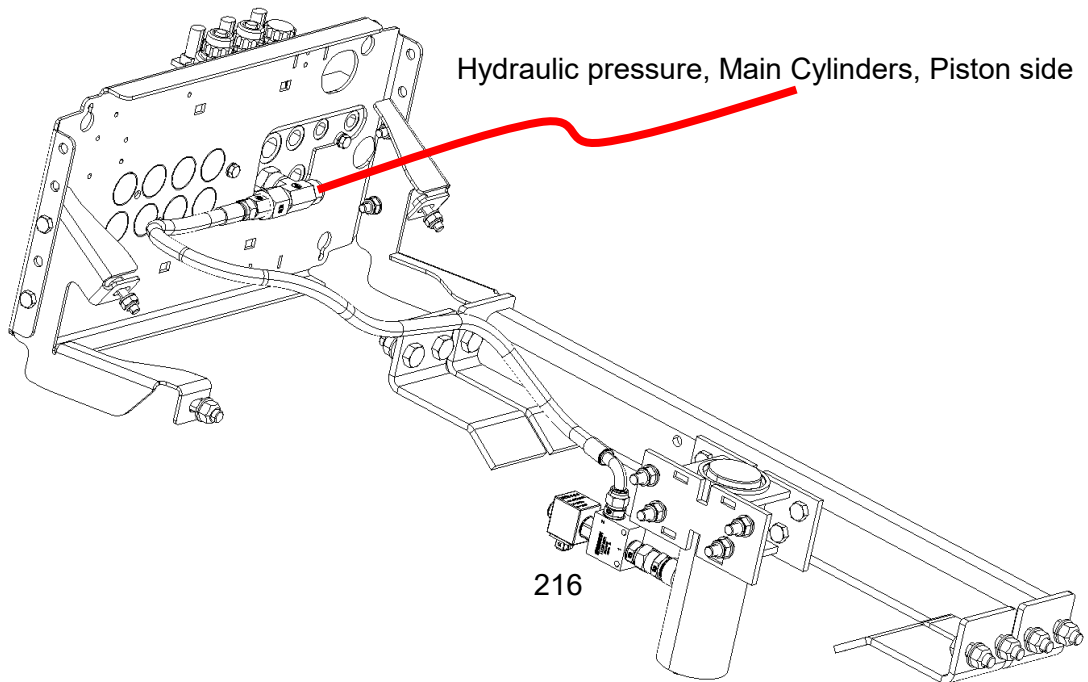

Always check that the valve is connected correctly:  
Standard unit: Port 2 to control valve and port 1 to cylinder\*  
Unit with friction relief: T to control valve and P to cylinder

NOTE. In case of friction relief retrofit the 2-way valve must be replaced with a correct valve type.

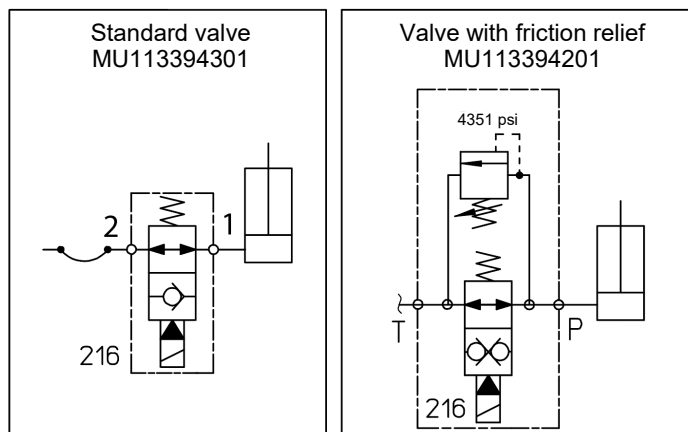

## 4 Hydraulic system

### 4.1 Safety precautions when installing hydraulic system

- The hydraulic system may only be installed by qualified personnel.
- Observe the utmost cleanliness (16/13 ISO 4406) while installing the hydraulic components. All hoses, pipes etc. components must be cleaned and free from machining an cutting burrs which can cause damage or malfunction to the hydraulic system.
- The hooklift has been tested at the factory under maximum permitted operating pressure. The pressure limiting cartridges of the control valves are not to be changed or adjusted due to risk of injuries to persons or damages to property in the surrounding area.
- The maximum operating pressure of the hydraulic system is 4351 psi (300 bar). Never touch the hoses or couplings when the system is under pressure.
- When raised to tipping position or with the middle frame raised, the frames must always rest on a suitable strong support before working near the unit to prevent unintentional lowering of frames and injuries to persons.
- The hydraulic oils are hazardous and must be handled according to local legislation and instructions. The safety data sheet of the hydraulic fluid must be available to the people working with the hydraulic system.

### 4.2 Specifications of the hydraulic system

The recommended oil flow and oil volumes for individual hooklift size is shown in the table next page.

The minimum size of oil tank is equal to one minute pump flow. The recommendation is to install as large oil tank as possible in front or side of the hooklift. The oil tank sizes available from the factory are between 20 - 53 gal.

The hooklift is delivered tested and cylinders filled with oil. The approximate amount of oil in the hooklift is shown in the table. The hydraulic fluid used in testing is ISO VG 22. Alternatively the oil is biodegradable ISO-L-HEES VG 32 which is then mentioned with a label in the oil tank and bracket of control valve.

The amount of hydraulic fluid needed to add in the system during the installation is:  
Oil tank volume + pump volume + pressure / suction line volume.

The diameter of suction, pressure and return lines are the minimum allowed diameters. Check the instructions of the pump manufacturer on the recommended pipe and hose diameters.

**The hydraulic fluid quality in factory delivered hooklift is  
ISO VG 22  
OR  
biodegradable ISO-L-HEES VG 32**

# Installation



Ultima Hooklift

01/2020

		<b>ULT14S</b>	<b>ULT16S</b>	<b>ULT18S</b>	<b>ULT18Z</b>		
Working pressure max.	psi	4351	4351	4351	4351		
Oil flow, recommended	gal/min	16	21	21	21		
Oil tank volume	gal	20-53	20-53	20-53	20-53		
Oil volume of hooklift	gal	13-17	17-21	17-21	20-25		
Total oil volume	gal	33-70	37-74	37-74	40-78		
Suction hose Ø	in	2½	2½	2½	2½		
Pressure line Ø	in	¾	¾	¾	¾		
Return line Ø	in	1	1	1	1		

		<b>ULT21S</b>	<b>ULT24S</b>	<b>ULT21Z</b>	<b>ULT26Z</b>	<b>ULT26S</b>	<b>ULT30S</b>
Working pressure max.	psi	4351	4351	4351	4351	4351	4351
Oil flow, recommended	gal/min	26	26	26	26	31	31
Oil tank volume	gal	20-53	20-53	20-53	20-53	20-53	20-53
Oil volume of hooklift	gal	21-26	21-26	26-30	26-30	28-37	28-37
Total oil volume	gal	41-79	41-79	46-83	46-83	48-90	48-90
Suction hose Ø	in	2½	2½	2½	2½	2½	2½
Pressure line Ø	in	¾	¾	¾	¾	¾	¾
Return line Ø	in	1	1	1	1	1	1

		<b>ULT18/21SL</b>	<b>ULT22/24/26SL</b>	<b>ULT20/24ZL</b>
Working pressure max.	psi	4351	4351	4351
Oil flow, recommended	gal/min	21	26	26
Oil tank volume	gal	20-53	20-53	20-53
Oil volume of hooklift	gal	18-20	22-25	27-28
Total oil volume	gal	38-73	42-78	47-81
Suction hose Ø, min.	in	2½	2½	2½
Pressure line Ø, min.	in	¾	¾	¾
Return line Ø, min.	in	1	1	1

## 4.3 Hydraulic connections ULTIMA BASE

Connect the suction hose from oil tank to pump with 2 ½" suction hose. 3" hose is recommended if pump size is 30 gal/min or larger. Keep the length of the hose as short as possible and install the oil tank higher than the pump. It is recommended to use a ball valve MU113273501 G2" or MU113273502 G2 ½" under the oil tank.

Connect the pressure line from the pump to the P port (R3/4") of the control valve of the hooklift with ¾" high pressure tube. Use also a high pressure hose size 5/8" or ¾" L=20" in between as a vibration damper. The high pressure filter is installed between the pump and the control valve. **The pressure filter is obligatory in Flex & Pro hooklifts and highly recommended in Base hooklift.**

Connect the return line from control valve (R1") to the return filter and keep the return line as straight and short as possible to avoid unnecessary warming of oil. The diameter of the tube is 1" and the diameter of the hose is 1".

In a heavy use (more than 30 platform changes a day), or hot working environment an oil cooler is recommended. See C-Service, Hiab accessories.

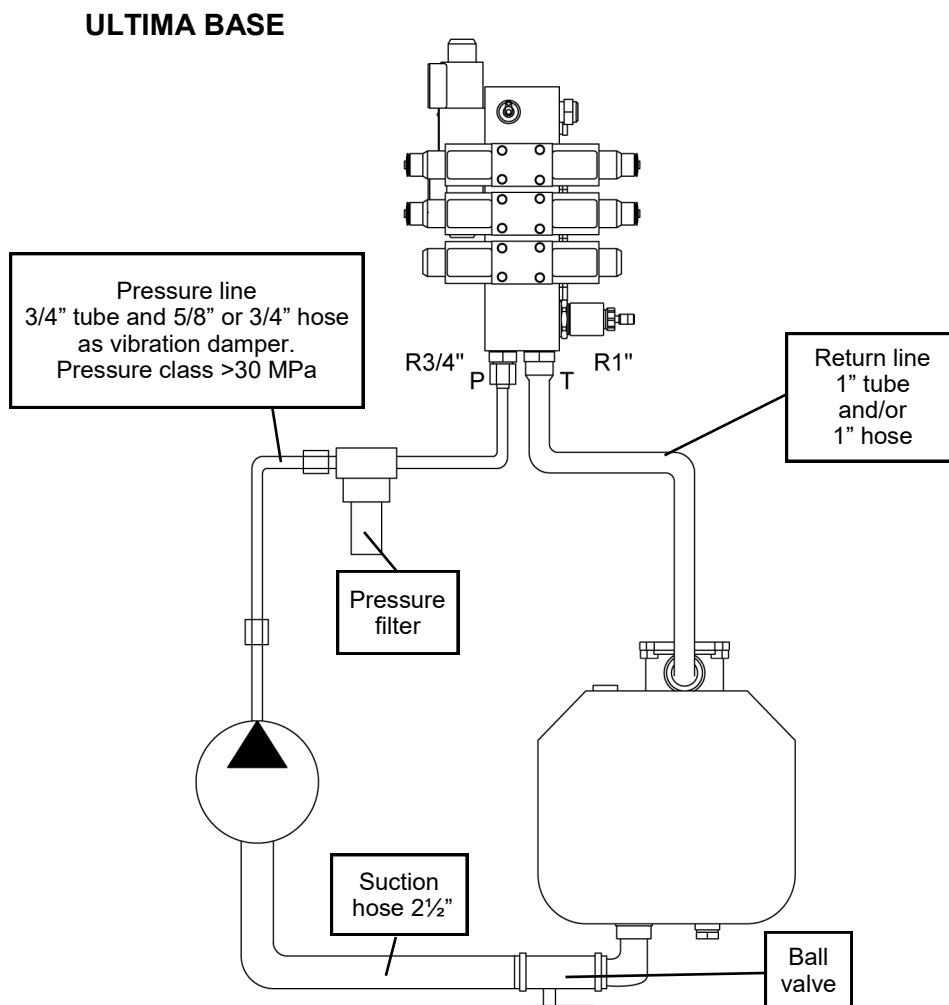

## 4.4 Hydraulic connections ULTIMA FLEX & PRO

Connect the suction hose from oil tank to pump with 2 ½" suction hose. 3" hose is recommended if pump size is 30 gal/min or larger. Keep the length of the hose as short as possible and install the oil tank higher than the pump. It is recommended to use a ball valve MU113273501 G2" or MU113273502 G2 ½" under the oil tank.

Connect the pressure line from the pump to the P port (R¾") of the control valve of the hooklift with 20 mm high pressure tube. Use also a high pressure hose size 5/8" or 3/4" L=20" in between as a vibration damper. The high pressure filter is installed between the pump and the control valve. **The pressure filter is obligatory in Flex & Pro hooklifts.** The pressure filter can be installed vertically or horizontally. Change of filter element will be easier with vertical installation due to less oil drain.

Connect the return line from control valve (R1") to the return filter and keep the return line as straight and short as possible to avoid unnecessary warming of oil. The diameter of the tube is 25 mm and the diameter of the hose is 1".

Install ¼" leakage line hose from control valve leak line port to the oil tank, not to return filter.

In a heavy use (more than 30 platform changes a day), or hot working environment an oil cooler is recommended. See C-Service, Hiab accessories.

### ULTIMA FLEX & PRO

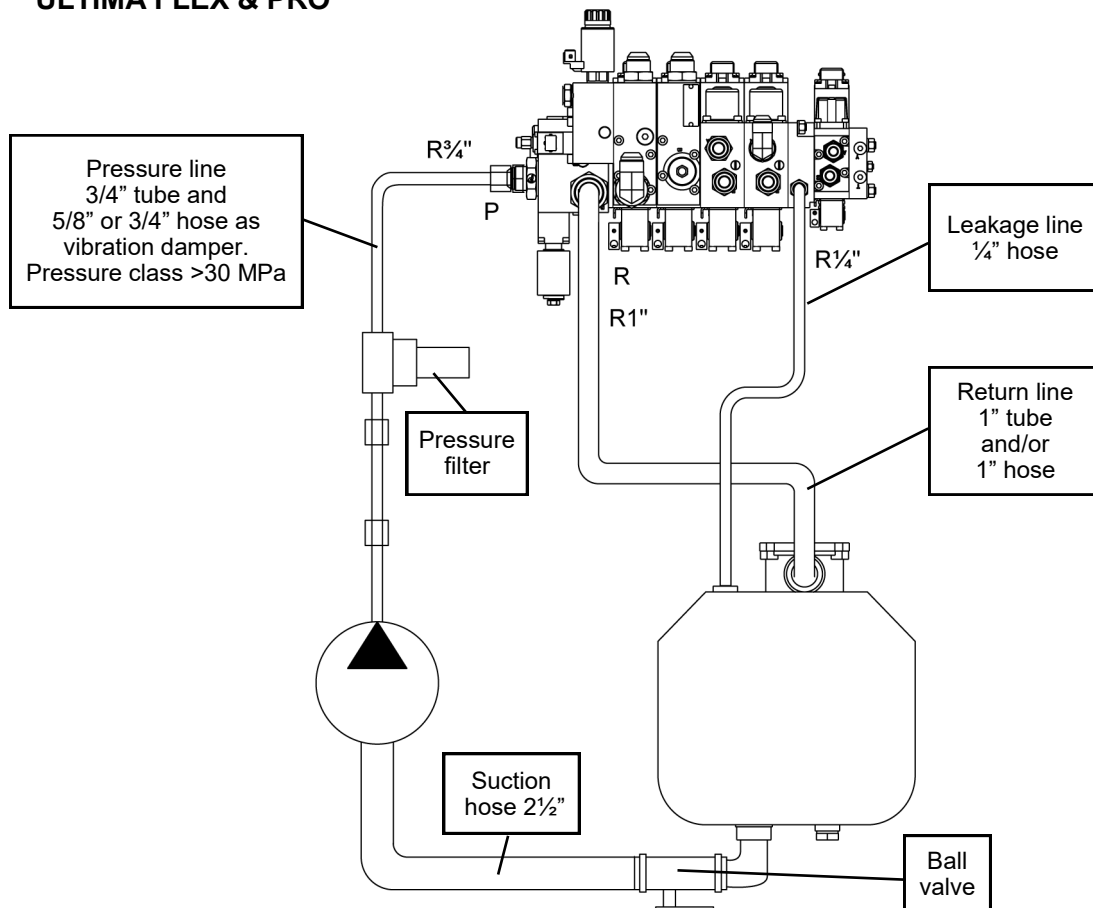

## 4.5 Hydraulic pump installation

Before installing the pump check the pump manufacturer's instructions for the dimensions, oil flow, torque, power and rotation speed and direction. The recommended oil flow and working pressure of the hooklift can be checked in the table in page 28. Under-sizing the pump will cause too slow operation of the hooklift and over-sizing the pump will cause unnecessary warming up of oil.

Check that the pump fits to the location to be installed and that the hooklift or other components do not prevent the installation. Check also the truck manufacturer's instructions.

The most common pump type in hooklift use is a fixed displacement pump installed on the gear box driven PTO. Alternative pump type is a fixed displacement pump installed on the engine driven PTO. In case of Ultima Flex or Pro, a variable displacement pump use is possible.

Before first start of the pump, remember to fill it up with hydraulic oil. Check the pump manufacturer's instruction on filling up and other possible procedures.

## 4.6 Variable pump LS line installation (Ultima Flex & Pro)

Check from the hooklift order if the Ultima control valve has factory installed LS line configuration for variable displacement pump. If it is so, then connect the LS line to the pump according to instructions in next page.

If the control valve is as standard for fixed displacement pump, then the valve configuration must be changed. The needed tools and working order are shown in next page.

Check if the compensator blocking pin p/n MU114131501 was ordered to the hooklift delivery and if not, then order it from Hiab WebShop.

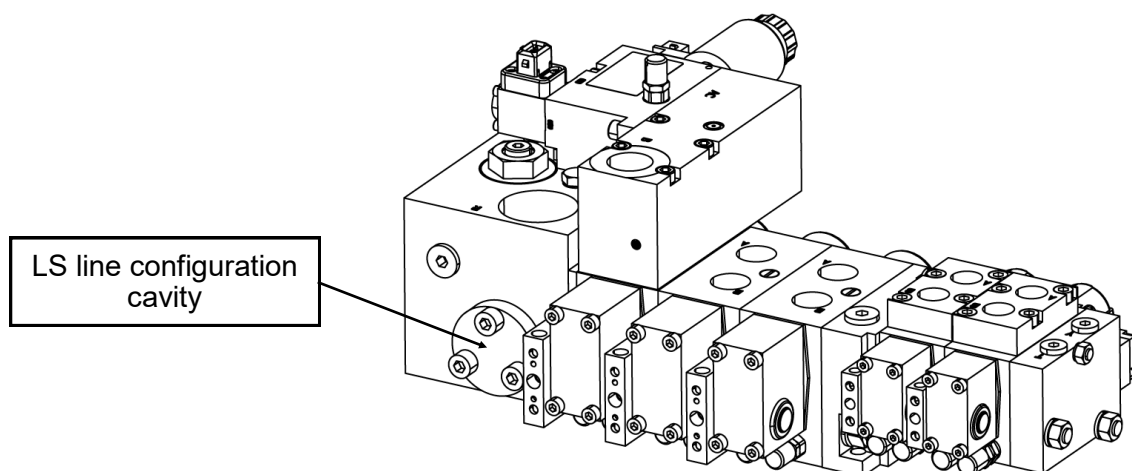

# Installation



Ultima Hooklift

01/2020

**Tools:**

- 6 mm hex key
- Torque wrench

**Recommended tools:**

- 8 mm hex key
- Clamp
- 2 x M8x50 bolts

1. Remove the upper bolt with 6 mm hex key.
2. Install clamp to hold the cap, make sure the clamp is able to open about 1-1½”.
3. Remove rest of the bolts.
4. Open the clamp carefully.
5. Remove the plunger.
6. Use 8 mm hex key (or similar) to remove the spring.
7. Replace the old pin with the new longer one (MU114131501 L=2.78” / 70,5 mm).
8. Push the plunger in using a bit of force so that the spring goes into its hole.
9. Place the cap back and use 2 x M8x50 bolts as a guide. Make sure that the red O-ring is in place!
10. Use clamp to press the plunger in.
11. Install 2 bolts and then remove the clamp.
12. Install the last bolt and tighten each one using torque wrench.  
Tightening torque 11.8 ft-lb.

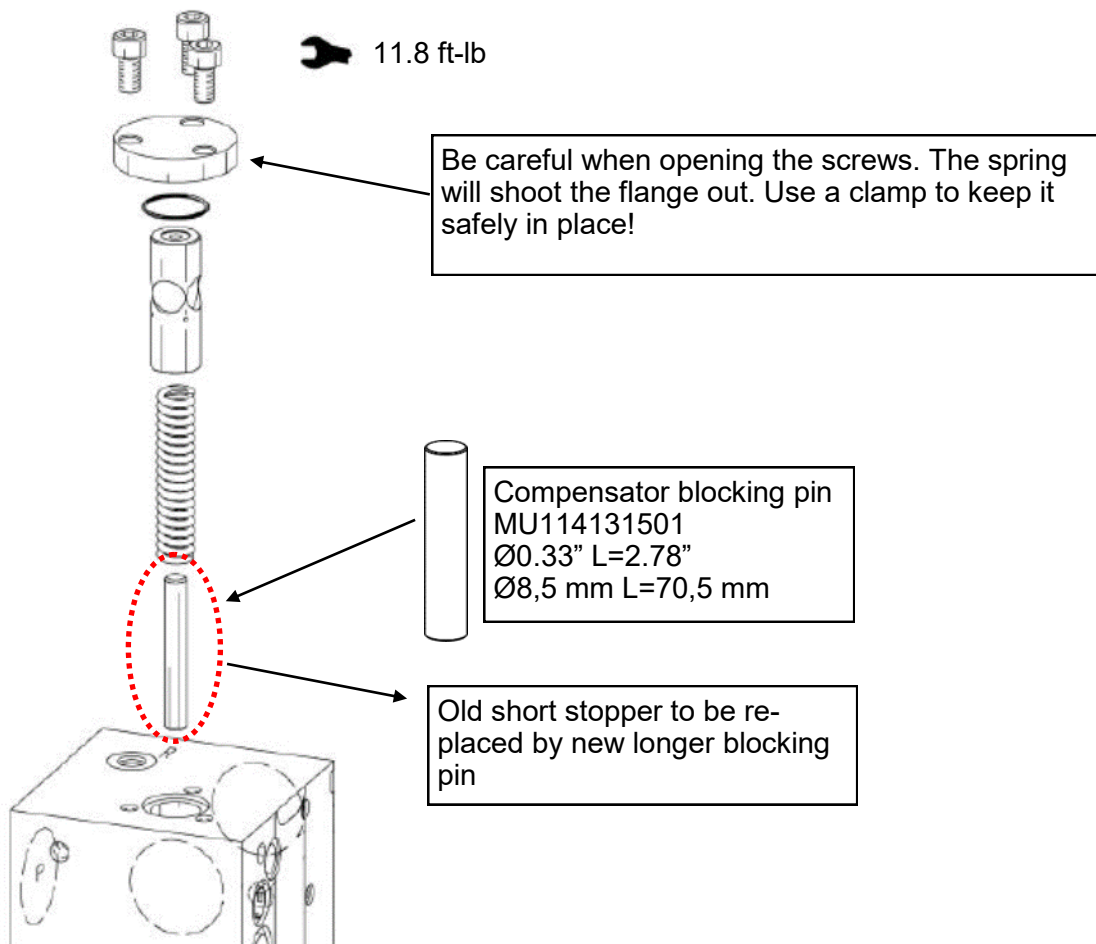



# Installation

Working order:

13. Remove the test point nipple and install suitable T-connector in the end of hose.
14. Install the test point nipple to T-connector.
15. Install proper LS line hose from T-connector to the pump.

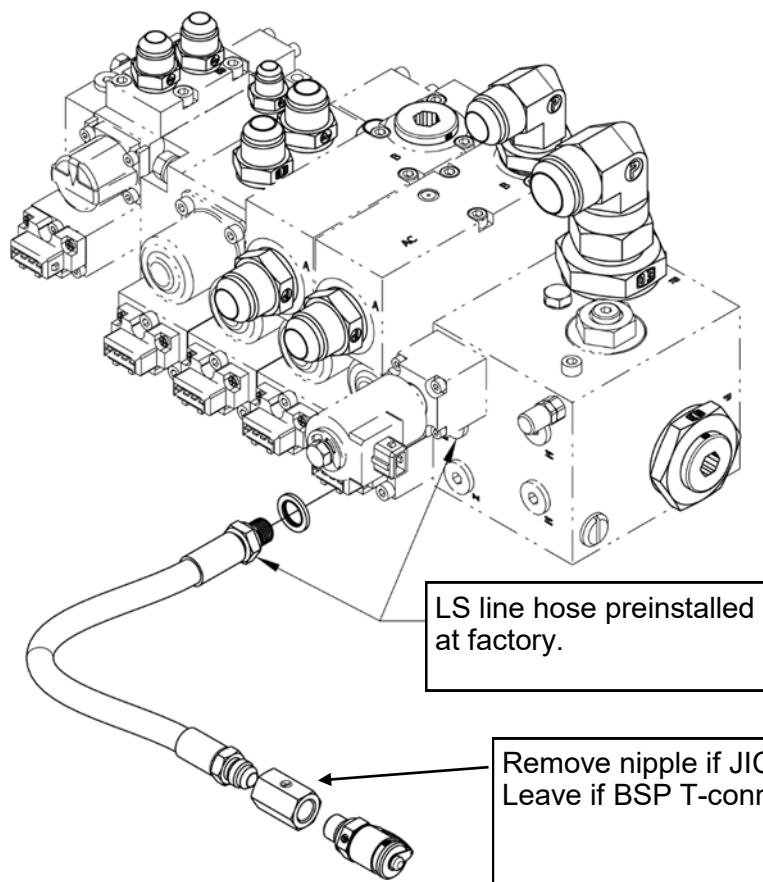

Use Multilift Service Tool to set the parameter:

**XM1.08 (DO) -> Supply voltage**

See also separate instructions "ULTIMA LS line configuration.pdf" and the instruction video in Multilift Product Site.

## 4.7 Oil tank

The oil tank should be installed as high as possible, so that the oil level in the tank will always be higher than the pump inlet level. The suction hose (2½" - 3") from oil tank to the pump and return line (1") must be kept as straight and short as possible. The suction hose must be properly supported.

The sizes of oil tanks in factory delivery are from 20 to 53 gallons. The 20 and 26 gal oil tanks are available with low flow or high flow return filter and the 40 and 53 litre oil tanks with high flow return filter. The oil flow capacity for the low flow return filter is 60 gal/min and for the high flow filter is 120 gal/min. The filtration degree for both is 10µm. The dimensions of the oil tanks are shown in next page.

It is important to choose the oil tank location to be accessible for inspection, filling and draining. The oil level checking is a daily routine so visibility of oil level gauge is important. Before filling the reservoir check that the interior of it is clean.

Ensure that the fastening of oil tank to the hooklift subframe and truck chassis can properly carry the weight of tank and oil in all conditions.

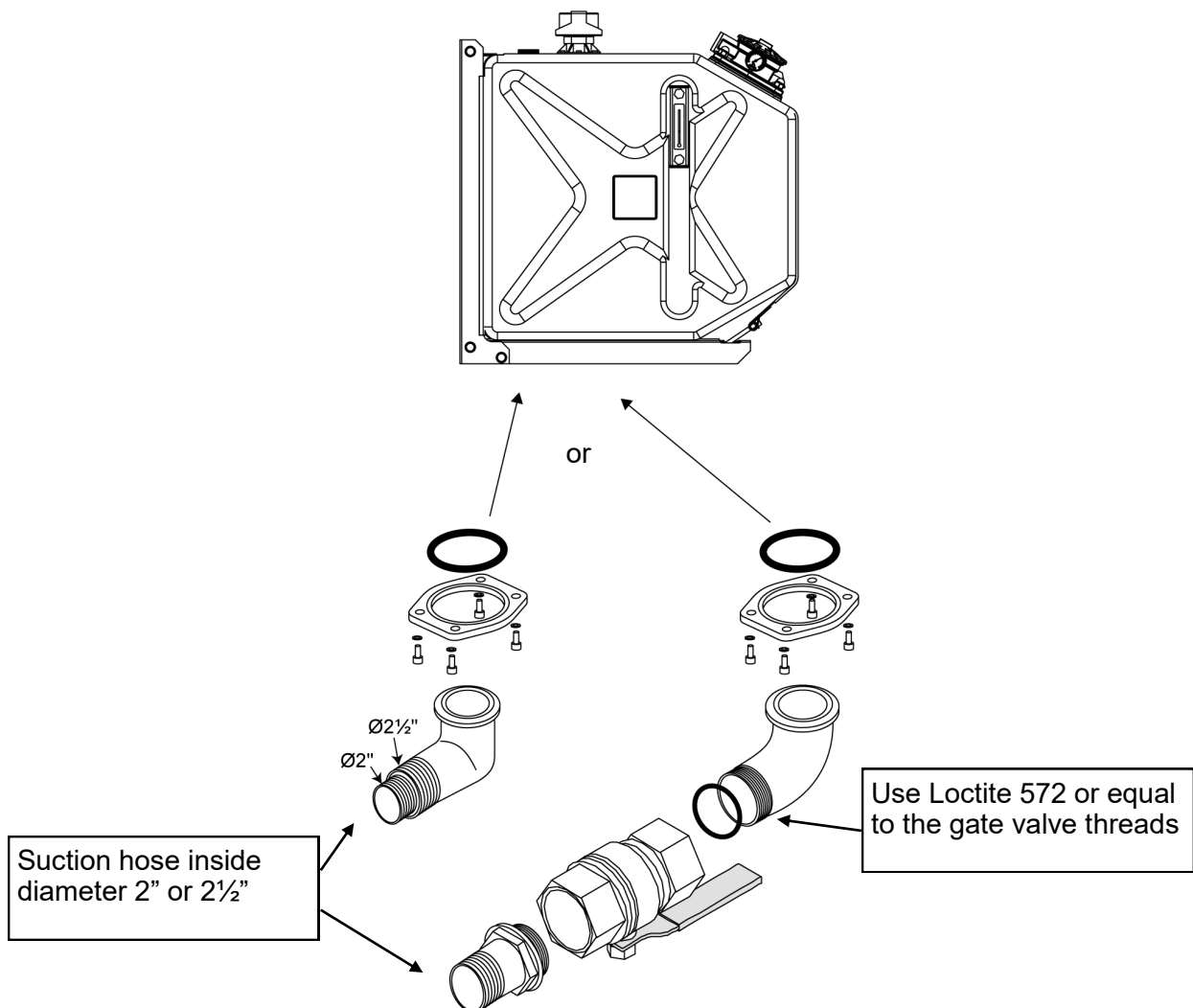

# Installation



Ultima Hooklift

01/2020

## Oil tank dimension, steel tanks

<p>113647201 20 gal small filter Iveco grey</p> <p>113647202 20 gal small filter Hiab black</p> <p>Hiab 339-7034</p>	<p>7.24<sup>0</sup><sub>-0.2</sub></p>	<p>26.8"</p> <p>25.7"</p>	<p>12.1<sup>+0.2</sup><sub>-0.08</sub></p>
<p>113647301 26 gal small filter Iveco grey</p> <p>Hiab 339-7035</p>		<p>26.8"</p> <p>25.7"</p>	<p>17.05<sup>+0.2</sup><sub>-0.08</sub></p>
<p>113647401 26 gal large filter Iveco grey</p> <p>113647402 26 gal large filter Hiab black</p> <p>Hiab 339-7036</p>		<p>26.8"</p> <p>25.7"</p>	<p>17.05<sup>+0.2</sup><sub>-0.08</sub></p>
<p>113647501 40 gal large filter Iveco grey</p> <p>Hiab 339-7038</p>		<p>26.8"</p> <p>25.7"</p>	<p>24.7<sup>+0.2</sup><sub>-0.08</sub></p>
<p>113647601 53 gal large filter Iveco grey</p> <p>Hiab 339-7041</p>		<p>26.8"</p> <p>25.7"</p>	<p>31.6<sup>+0.2</sup><sub>-0.08</sub></p>

### Oil tank dimension, aluminium tanks

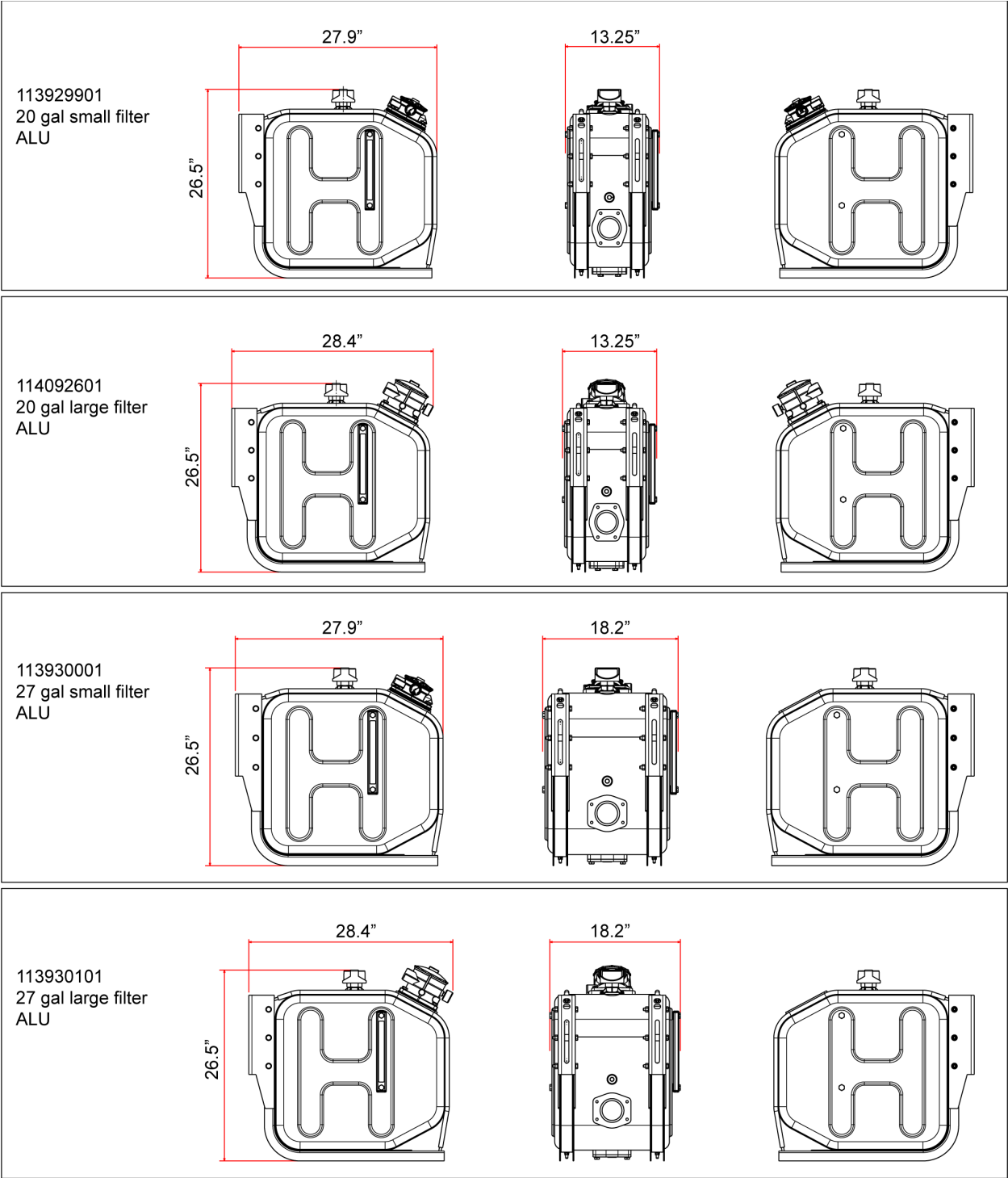

## 4.8 Hydraulic oil

Before filling up the oil check the interior of the oil tank for impurities and rust. Fill the tank up to the maximum level shown in the oil level gauge. Carefully operate all the hooklift cylinders fully in and out 4 to 5 times to remove the air from the hydraulic system. Check the oil level and fill up if needed. The sliding cylinder must be operated in when checking the oil level. The oil level must not exceed the maximum level.

The Ultima hooklift is delivered tested and cylinders filled with ISO VG 22 mineral oil, which meets ISO 11158HV and DIN 51524 part 3 HVLP requirements. Alternatively the hooklift is tested with ISO-L-HEES biodegradable oil, which is mentioned with a label in the oil tank and bracket of control valve.

Always use similar type hydraulic oil which meets the following requirements:

- ISO6743/4 type HM and HV
- DIN 51525 part H-LP
- SMS norm for hydraulic oils (SS 15 54 34AV)
- Oil quality according to ISO VG with max impurities 9 NAS 1638

The oil viscosity must be chosen according to ambient operation temperature, especially in case of extremely low or high temperatures another ISO VG grade hydraulic fluid must be used.

In case of environmental friendlier hydraulic fluid (known as Bio-oil) the oil type must be synthetic bio oil. A vegetable oil is not permitted because of possible damages in seals and gaskets. When changing the mineral oil to bio oil the whole hydraulic system must be drained and flushed several times thoroughly in order to achieve the required cleanliness. To obtain the best results, the percentage of the mineral oil should not exceed 2% of the oil volume. Contact factory for possible bio-oil options.

Procedure for changing the oil type and viscosity class is the following:

1. Drain the hydraulic system from existing oil.
2. Fill the system with new filtered oil to a level to run the hooklift. Take into consideration that the whole system is empty. The oil volume must be enough to fill the system and also the pump must be able to get oil without any problem. Run the oil up to normal temperature and operate all functions 4 to 5 times.
3. Operate the main cylinders and sliding arm cylinder in.
4. Drain the system as empty as possible.
5. Fill the system with new oil. Operate the hooklift as in point 2.
6. Repeat 2, 3 and 4 until the amount of mineral oil is under 2% of total volume. Change all oil filters to new ones.
7. Change all oil filters after max. 50 working hours.

The hydraulic oils, especially mineral oils, are hazardous and must be disposed of in proper manner and according to local authority regulations. Polluted soil must always be collected and disposed of according to local legislation.

The safety data sheet of the hydraulic fluid must be available to the people working with the hydraulic system. Hydraulic oils can irritate the skin and this may cause a serious skin conditions. Always use hand protection against grease and oil. Clean your hands after service and use a hand cream to protect them. Remember also always to protect eyes against contamination.

## 5. PLC Control System

### 5.1 Installation of the control system

**NOTE!** In case of **Ultima Flex or Pro**, check the possibility to utilize the truck interface cables for the connections of the cabin controller to reduce installation time. Instructions for Scania and Volvo can be found in Multilift Product Site.

The PLC control system is designed to be connected to 24V electrical system. In case of connection to 12V electrical system a voltage converter 12-24VDC (min. 10A) must be used.

Most of the cables and wires are installed at factory, except the power feed (L=36 ft), the CAN extension cable (L=33 ft) and the adapter cable to control unit (L=3.2 ft). The power cord wires are marked with yellow + and - labels. The wires are also marked with numbers: 1 = +24V and 2 = GND (-). Always make sure that the wires are installed correct way. Connecting wrong may cause to short circuit in I/O module.

Connect the power feed of the hooklift to a connection bridge for accessories in the truck. Power feed must be protected with 10A fuse. Recommendation is to take the power after ignition key (KL15). Check that the power feed is stable and stays on also when PTO is not on. The warning lights of hooklift must stay on while driving. Check the truck manufacturer's instructions on connecting the accessories. Use existing holes (Ø 0.3") in the cabin to draw the cable. It is not recommended to take the power directly from the battery because it might run empty in longer period.

The PLC control system is protected against under and over voltage. Multilift control unit will prompt an error message if the voltage lowers below 18 V or gets over 30 V. Over and under voltage errors are logged and can be examined with the service tool's diagnostics tool.

Any voltage below 15V or over 33V activates a safety circuit in I/O module and the hooklift will be inoperative. After the power returns to normal level, the safety circuit will release automatically. In some trucks the voltage may drop under 16V while cranking the engine and in some trucks may have charging voltage over 30V. Always check these conditions from truck manufacturer.

Before welding anything in the hooklift or the truck, disconnect all connectors from I/O module. Check the truck manufacturer's instruction for welding job.

Any self-made electrical connections to the cables, wires and solenoids are strictly forbidden because they might interfere the CAN signals. Most of the additional functions have standby connectors in the wiring harnesses. Consult manufacturer for additional information.

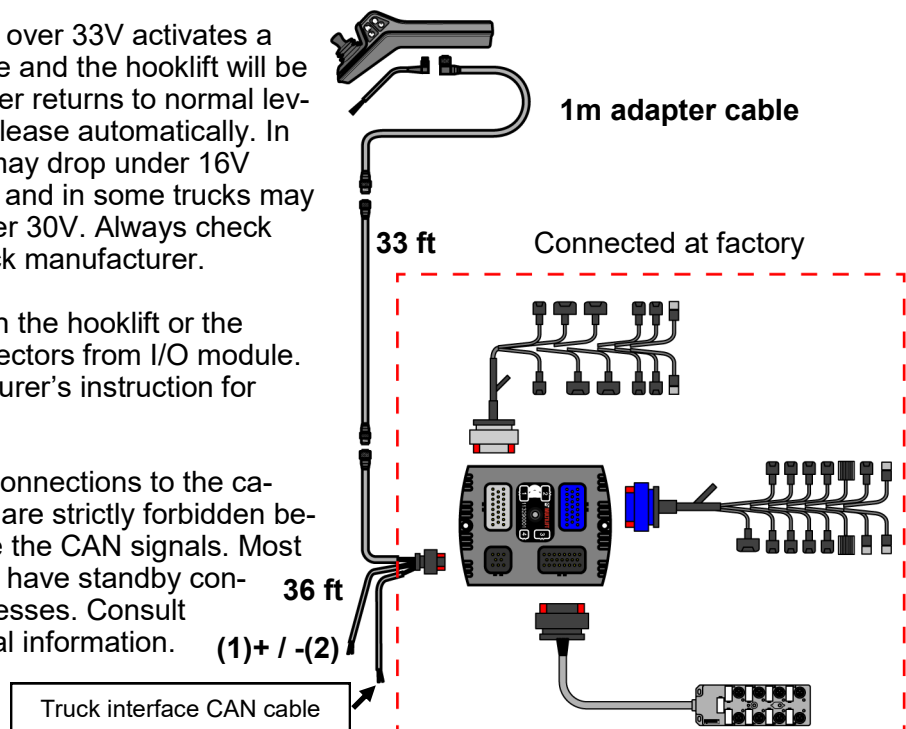

# Installation



Ultima Hooklift

01/2020

**The 3.2 ft adapter cable must be connected to the control unit!  
The control system does not work without it!**

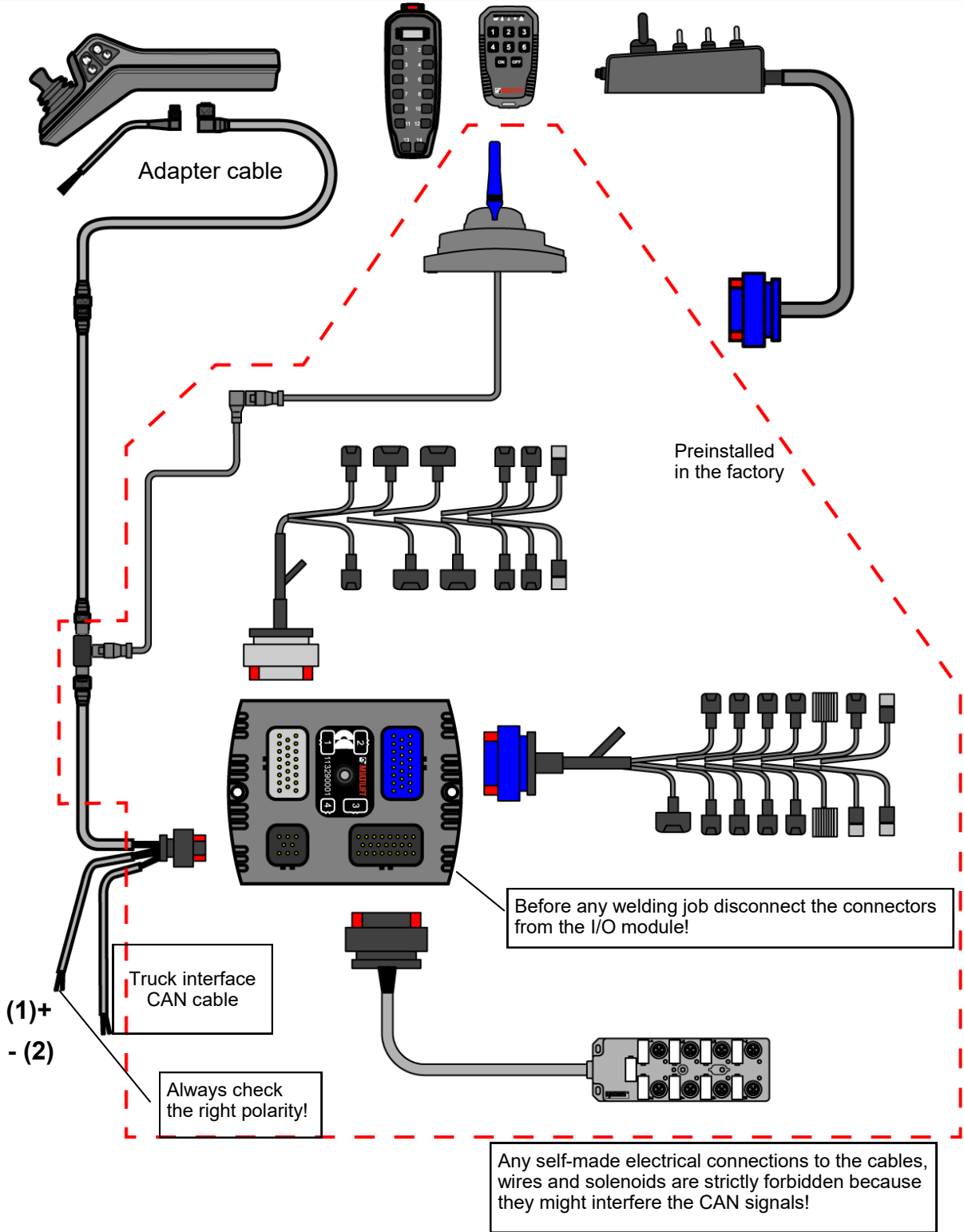

## 5.2 Installation of the control unit

Choose a location for the control unit in the cabin together with the customer. A suitable location is one where the operator can reach the controls and see the signal lights easily from driver's seat effortlessly while controlling the hooklift movements through rear window and mirrors. A recommended location is between the seats. An alternative location for the control unit is on the cabin handle bar.

If the remote is installed between the driver's seat and the door the joystick can get damaged while climbing off the truck. Check that the control unit does not disturb climbing up and down the seat and that it can be used the door closed. Make sure the rain does not fall on the control unit when the door is open.

The M12 male connector in the cable of control unit is connected to the M12 female connector in the cable coming from the hooklift. Leave the connectors in a suitable location where they are easy to access for possible software updates.

Fasten the stand of control unit with  $\frac{1}{4}$ " screws. The angle of control unit can be adjusted with the screws in the stand.

In case the dash board harness for warning lights is included check the suitable cable routing to dash board. See connections in chapter 6.1.

**NOTE!** In case of **Ultima Flex or Pro**, check the possibility to utilize the truck interface cables for the connections of the cabin controller to reduce installation time. Instructions for Scania and Volvo can be found in Multilift Product Site.

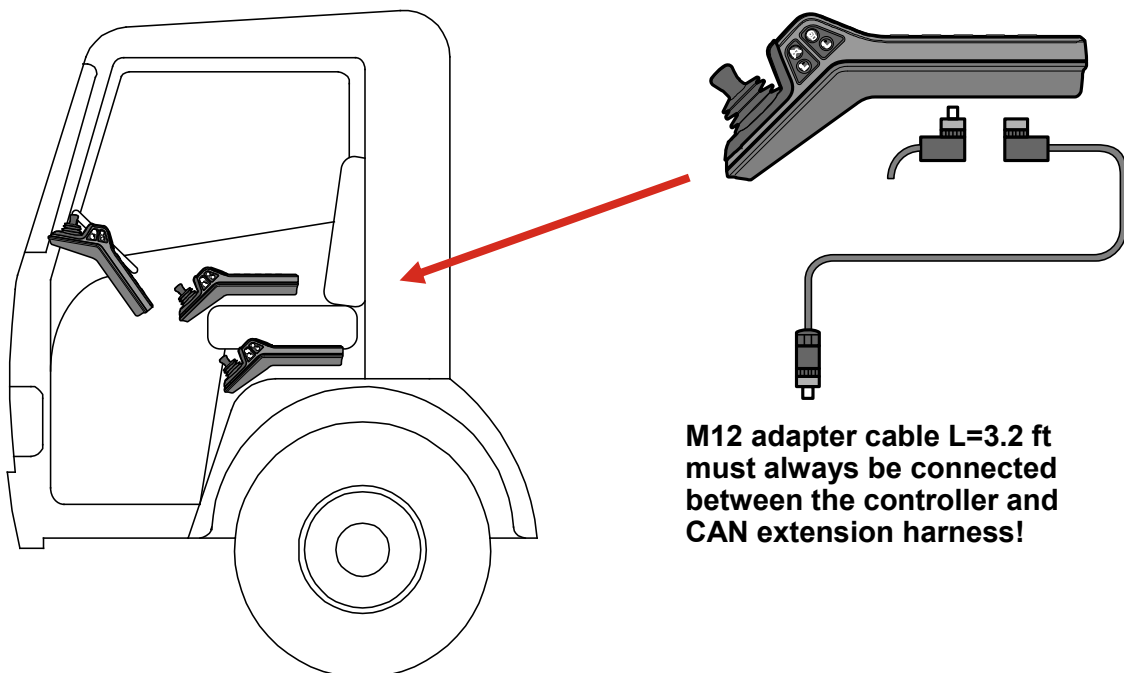



# Installation



Ultima Hooklift

01/2020

Install the cable from hooklift through the existing holes in the cabin and check the tightness of lead-in.

If the cabin has tilting mechanism then the cable must be run around the tilting mechanism. Check that the cable can't get squeezed in the cabin construction.

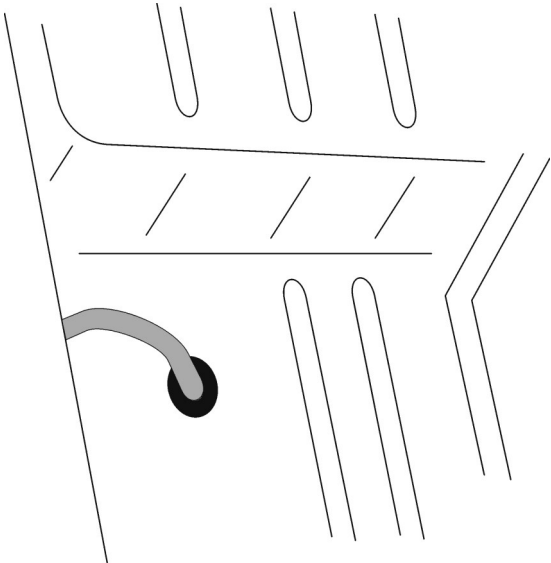

Power feed 10A. Use only free connection place which does not have other electric devices connected.

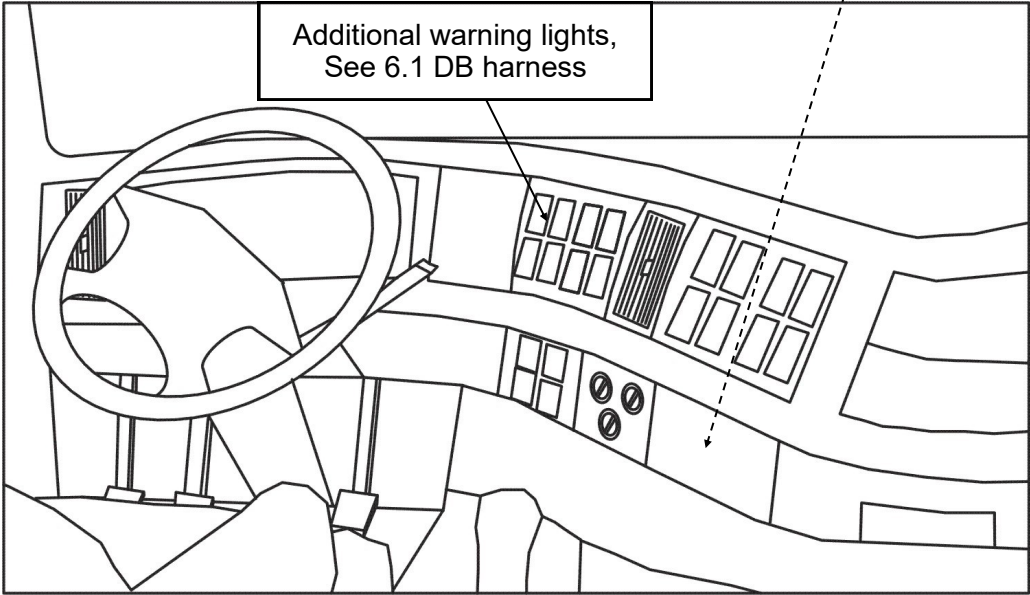

## 2GCC Bracket, Basic, Fixed

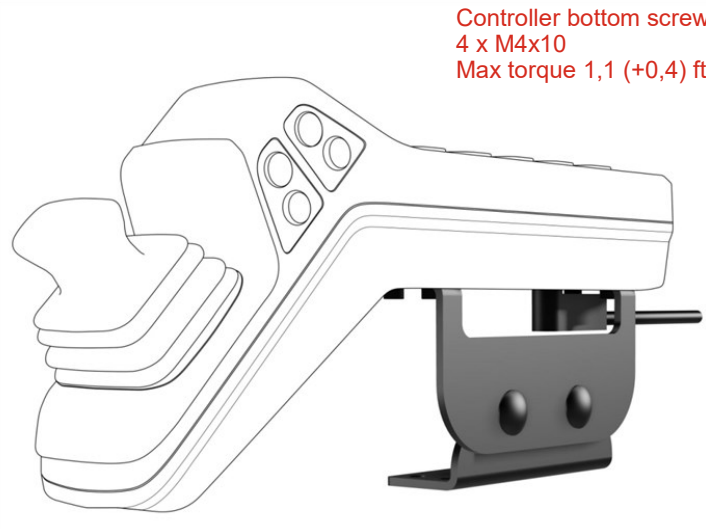

Controller bottom screw  
4 x M4x10  
Max torque 1,1 (+0,4) ft-lb

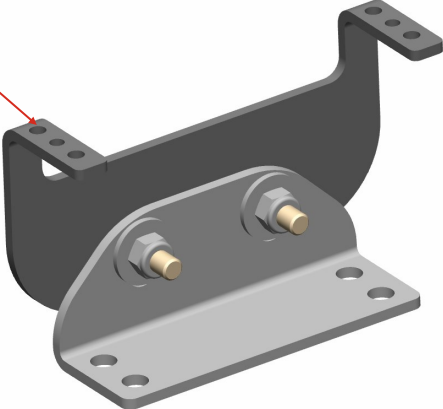

113170001 Basic Bracket, Fixed

## 2GCC Handle Bracket, Fixed

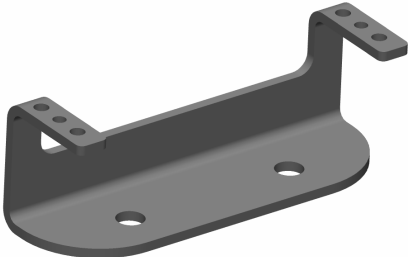
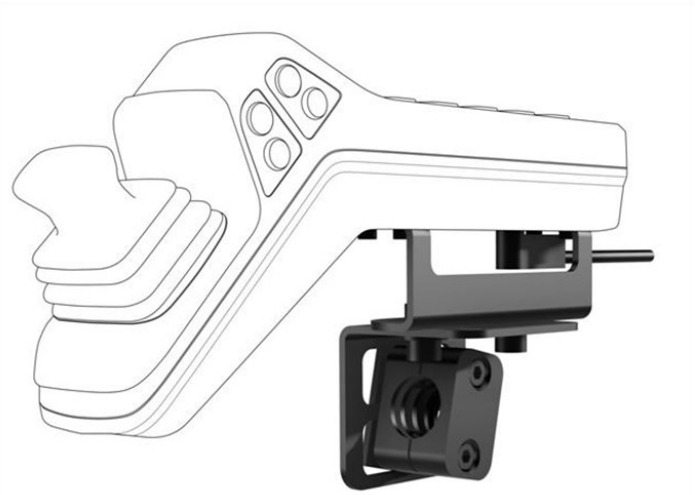

112992201 Base plate

113170201 Handle Bracket



# Installation



Ultima Hooklift

01/2020

## 2GCC Armrest

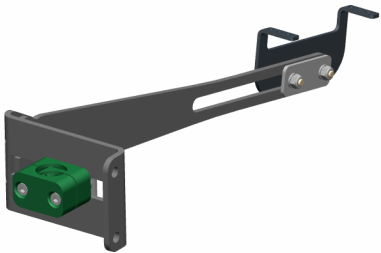
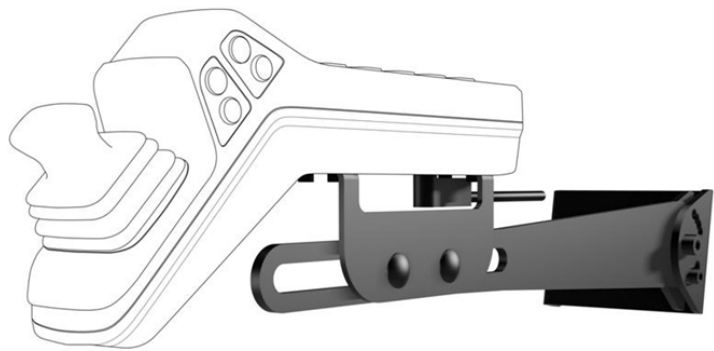

113170101 Armrest

## 2GCC Basic Bracket, Removable

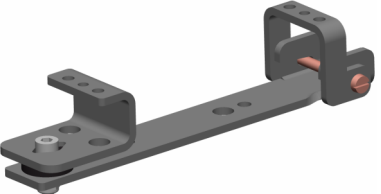
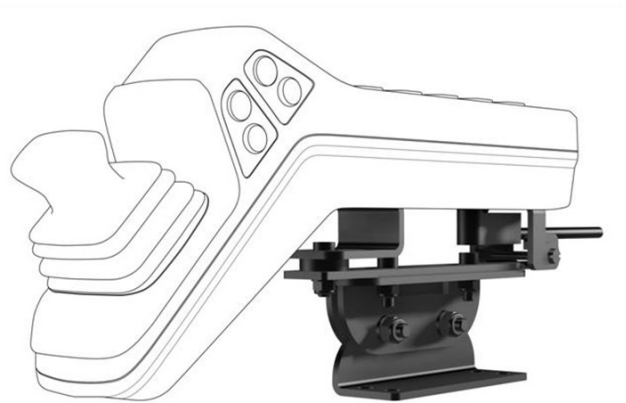

112992301 Magnet Bracket

113147901 Base Bracket

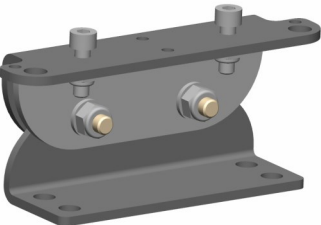

## 2GCC Handle Bracket, Removable

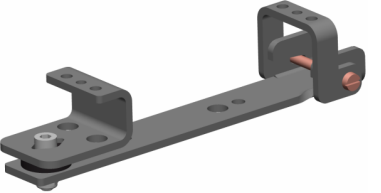
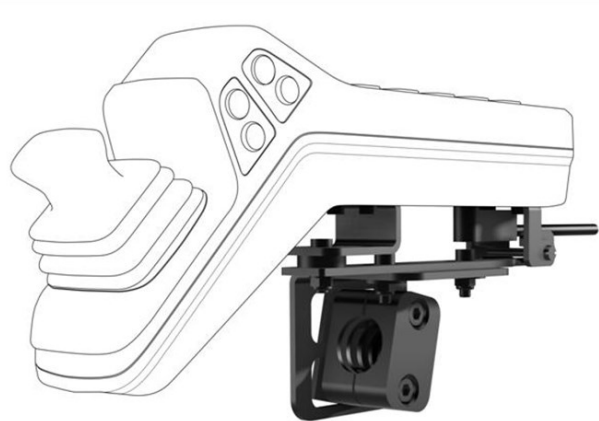

112992301 Magnet Bracket

113170201 Handle Bracket

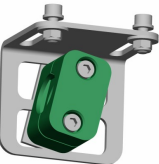

## 5.3 Installation of the Trailer tipping "High flow" ULTIMA BASE

Before installing the pneumatic system check the truck manufacturer's instructions on the correct connection and the system pressure. The working pressure of the hooklift components is 100 psi. The maximum pressure for the pneumatic system is 145 psi. Use pressure regulator if needed.

The solenoid valves (Herion) where the air feed is connected are located next to the trailer tipping high flow valve. Remember to follow cleanliness guidelines when installing the pneumatic connections.

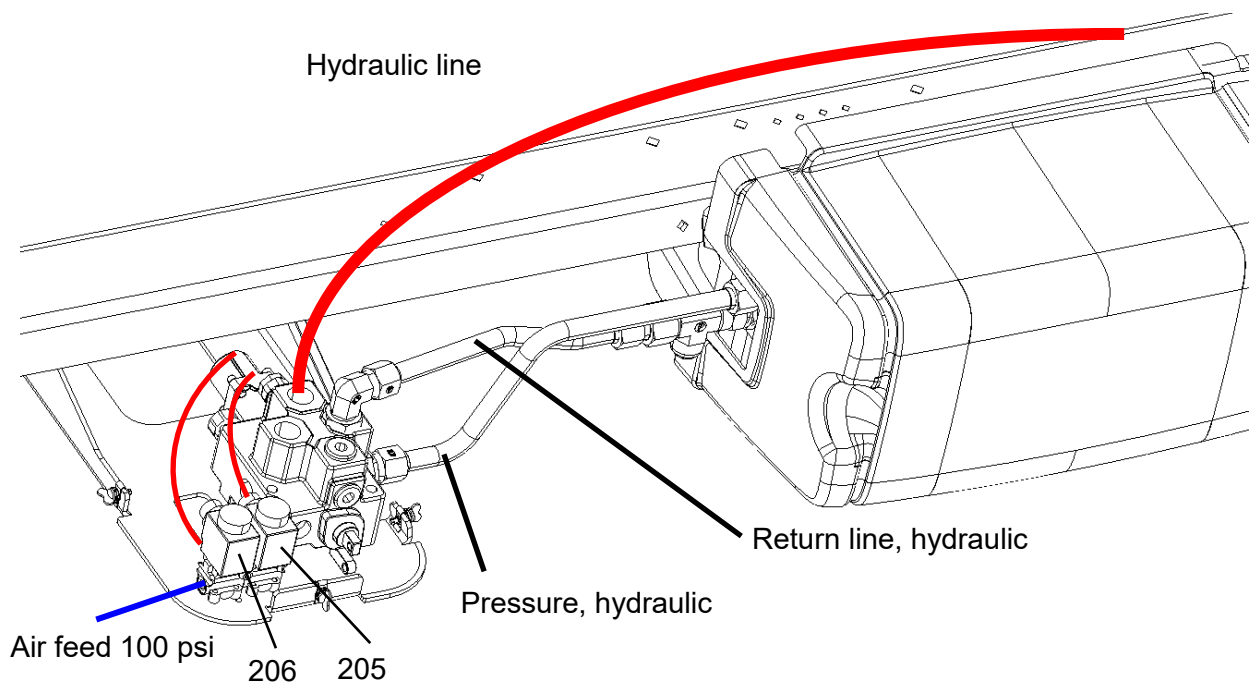
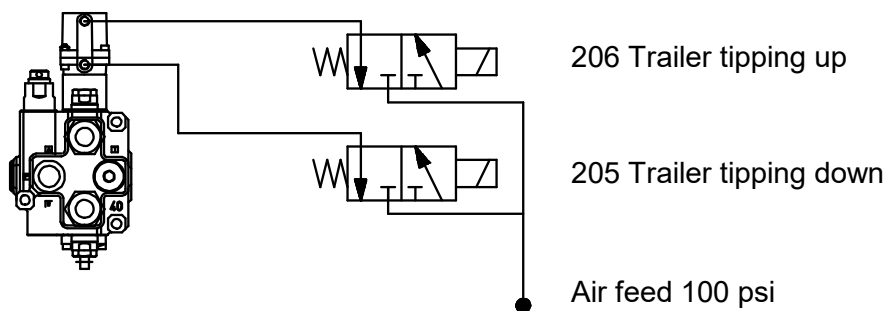

## 5.4 Installation of the Pneumatic hook lock / safety latch

Before installing the pneumatic system check the truck manufacturer's instructions on the correct connection and the system pressure. The working pressure of the hooklift components is 100 psi. The maximum pressure for the pneumatic system is 145 psi. Use pressure regulator if needed.

The solenoid valve (Herion) where the air feed is connected is located next to the main control valve. Remember to follow cleanliness guidelines when installing the pneumatic connections.

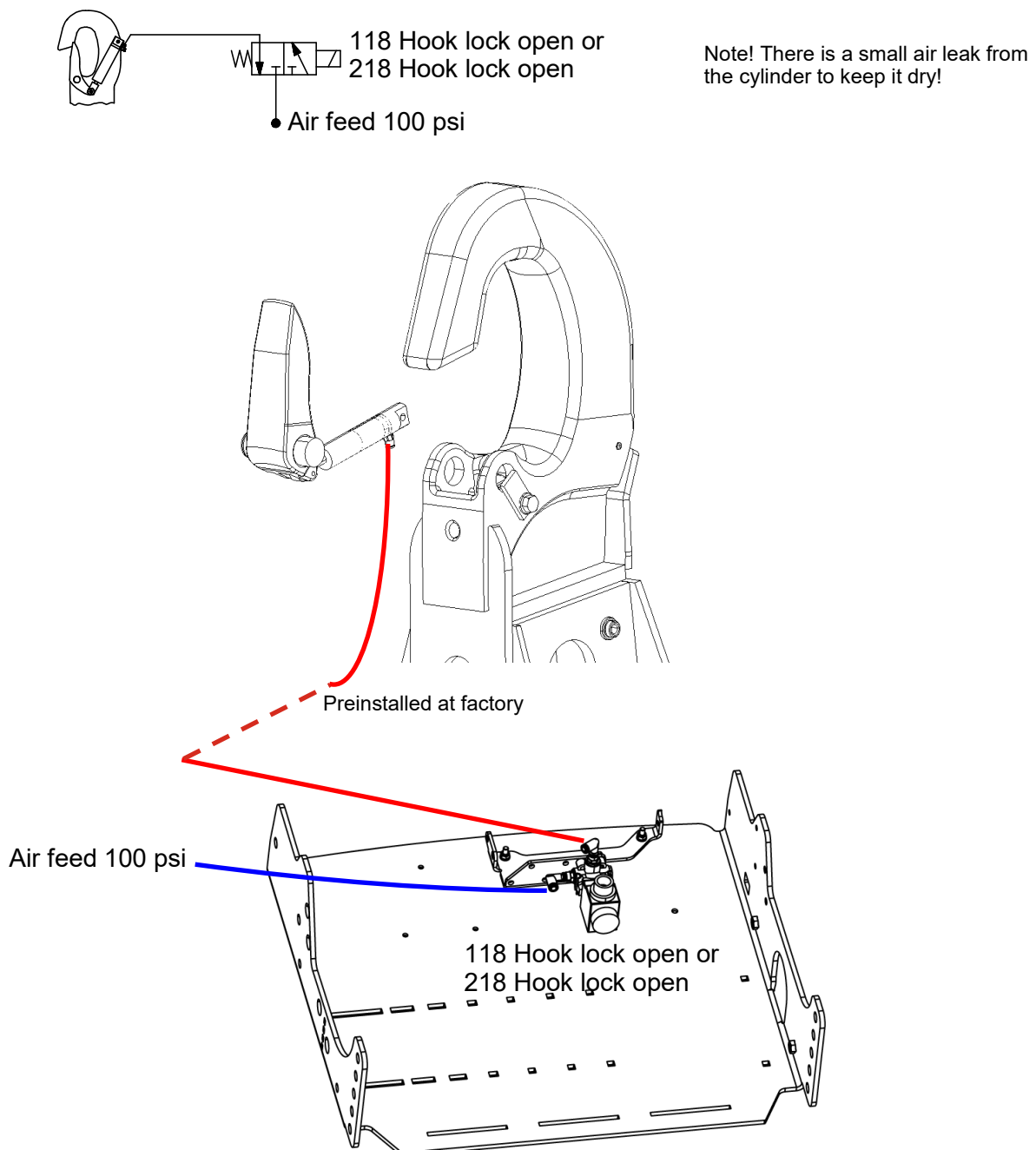

## 6 Accessories

### 6.1 Dashboard harness (Optional in Ultima Flex & Pro)

The dashboard harness is used to connect additional warning lights, warnings buzzer or other signal information into the dashboard of the truck. If the hooklift is delivered with the dashboard harness there is a 33 ft 5-wire M12 cable included in the packing box. Install the cable into the dashboard warning lights / buzzer is located and connect the M12 connector in the bottom of the control unit.

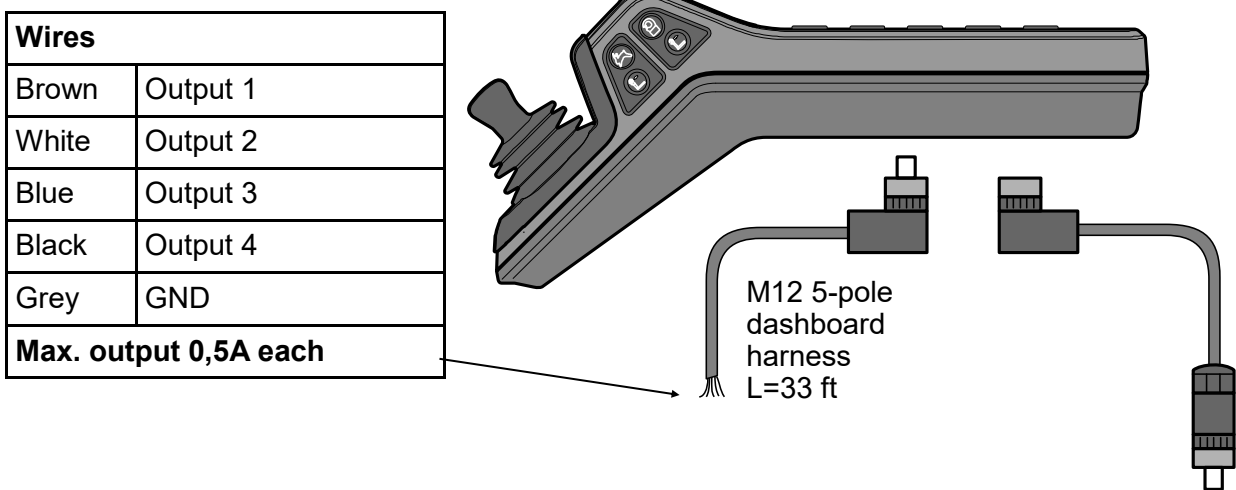

Adjust the outputs with the service tool software.

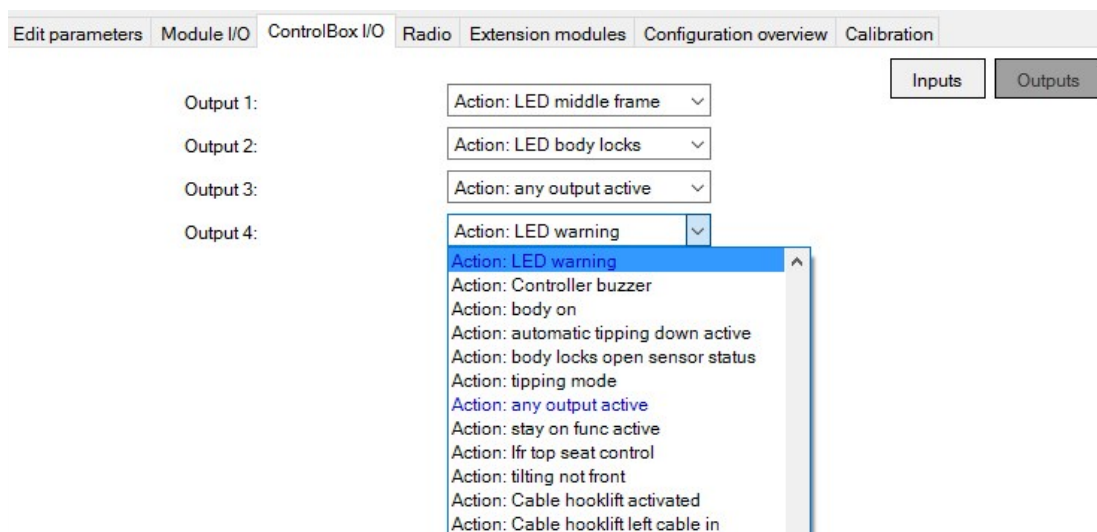

## 6.2 Top Seat Control (Optional in Ultima Flex & Pro)

Top seat control allows the user to operate hooklift from loader crane cabin or other location. Top seat control module is preinstalled and parameters are set in the control system. The top seat controller (1) or alternative controller cable (2) without controller are located in the packing box. Install the controller to a suitable place where it is easy to use. The emergency stop is set on as standard. When the emergency stop button is pushed down, then the text “StOP” appears in the display of the cabin controller. When the top seat controller is activated, then a text “-C2-” appears in the display.

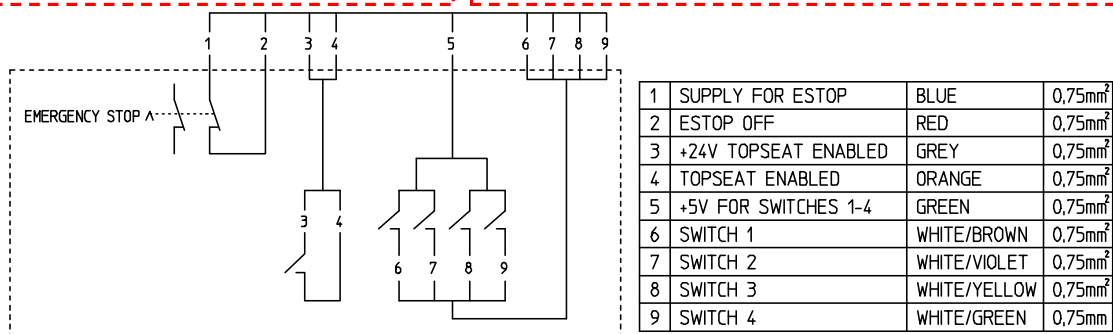
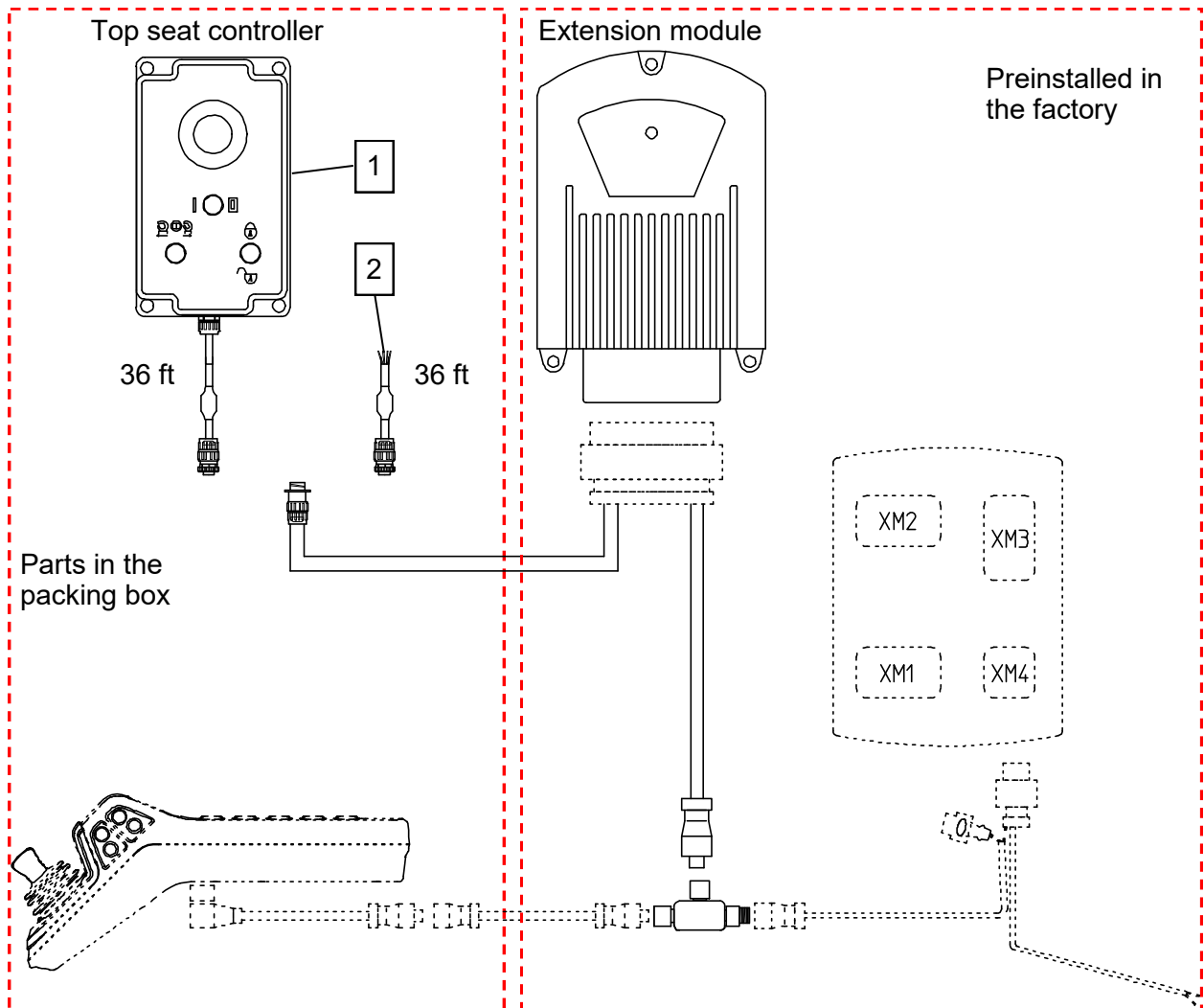

## 6.3 External Control (Optional in Ultima Flex & Pro)

External controls option allows the user to operate hooklift with another controller for instance a loader crane controller. External controls harness is preinstalled and parameters are set to the control system. Install the cables 1, 2 and 3 to the external control system according to the instruction given by the manufacturer. When the external controller is activated, then a text “-C2-” appears in the display of the cabin controller.

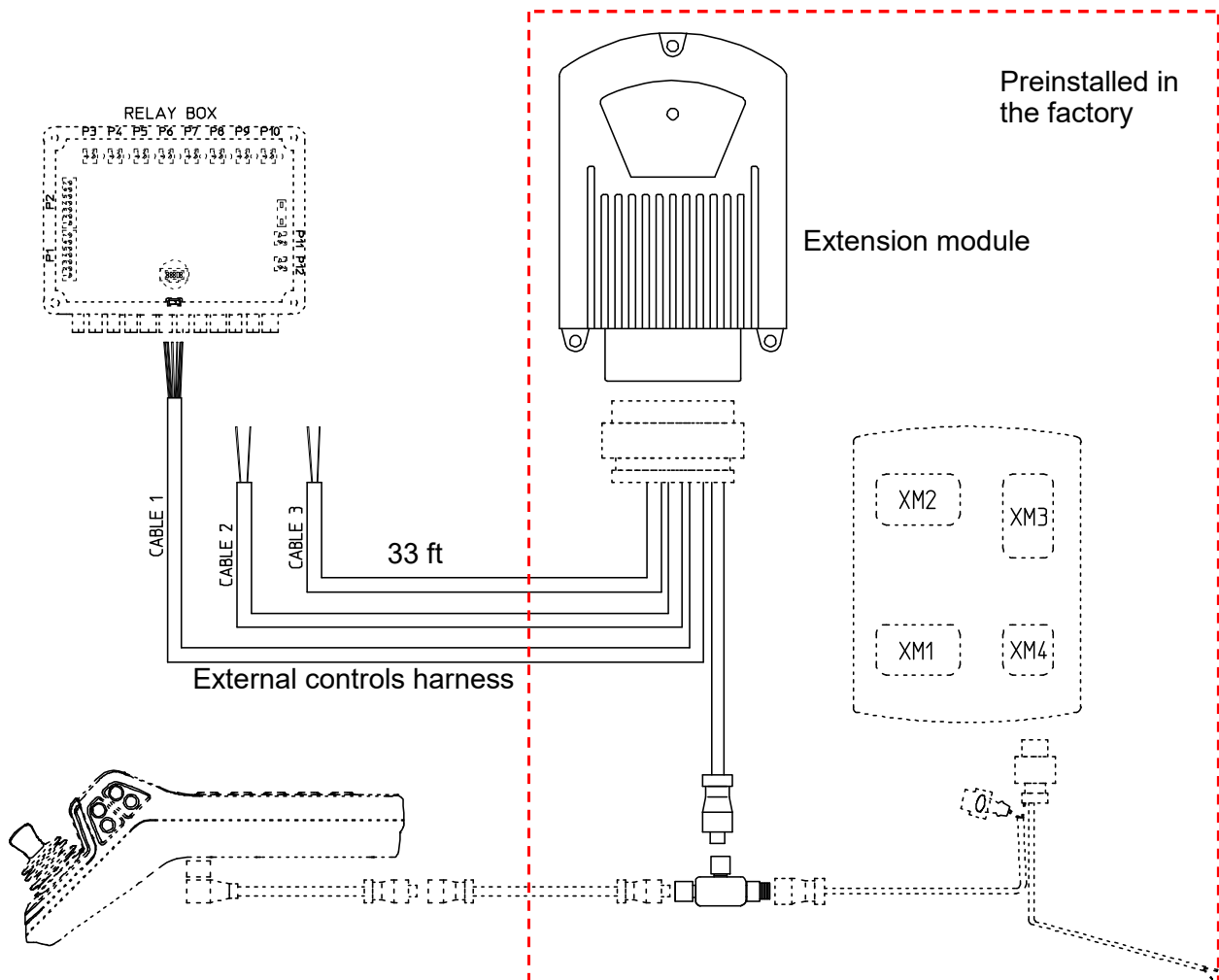

3.1	SWITCH 1	Sliding forward	BLUE	0,75mm <sup>2</sup>	120
3.2	SWITCH 2	Sliding backward	RED	0,75mm <sup>2</sup>	121
3.3	SWITCH 3	Open body locks	GREY	0,75mm <sup>2</sup>	131
3.4	SWITCH 4	Close body locks	ORANGE	0,75mm <sup>2</sup>	132
3.5	SWITCH 5	Tilting forward	GREEN	0,75mm <sup>2</sup>	115
3.6	SWITCH 6	Tilting backward	WHITE/BROWN	0,75mm <sup>2</sup>	125
3.7	SWITCH 7	Main cyl. in	WHITE/VIOLET	0,75mm <sup>2</sup>	126
3.8	SWITCH 8	Main cyl. out	WHITE/YELLOW	0,75mm <sup>2</sup>	127

4.1	SUPPLY FOR ESTOP	BLUE	0,75mm <sup>2</sup>	102
4.2	ESTOP OFF	RED	0,75mm <sup>2</sup>	103

5.1	+24V TOPSEAT ENABLED	GREY	0,75mm <sup>2</sup>	111
5.2	TOPSEAT ENABLED	ORANGE	0,75mm <sup>2</sup>	114

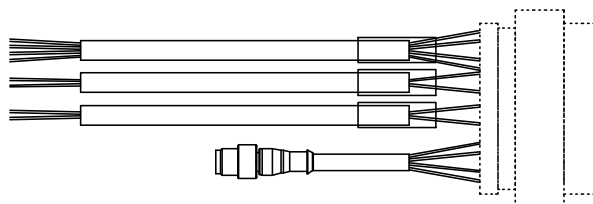



### 6.4 Stop button

The power feed stop button is cutting the power feed to the hooklift and is connected between the power feed cable inside the cabin.

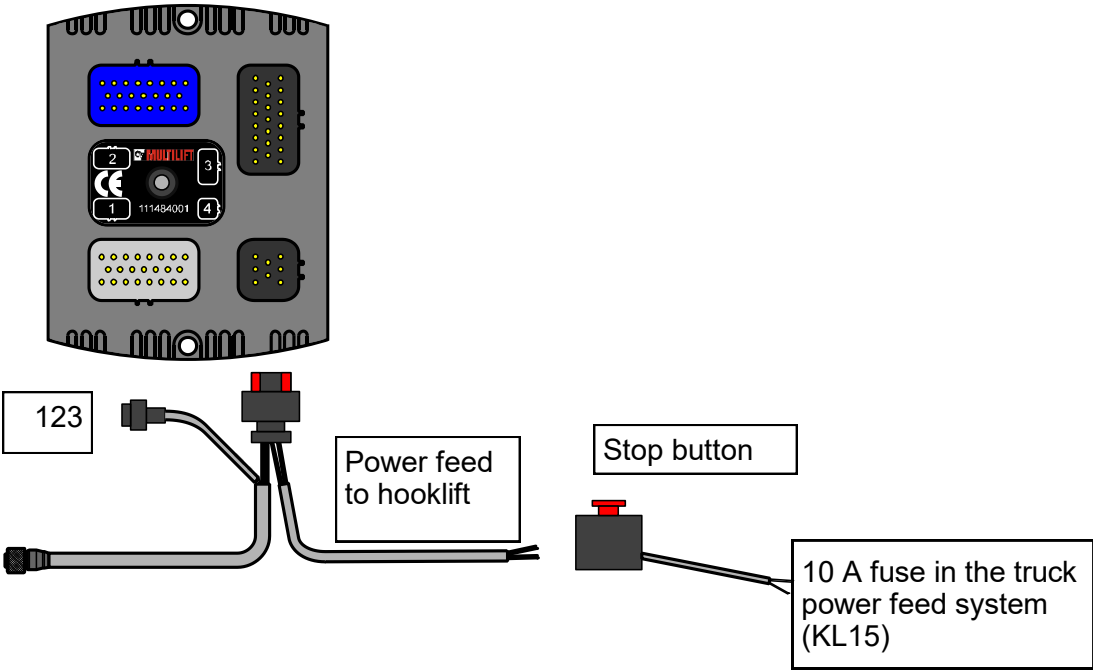

### 111694001 Stop button, inside

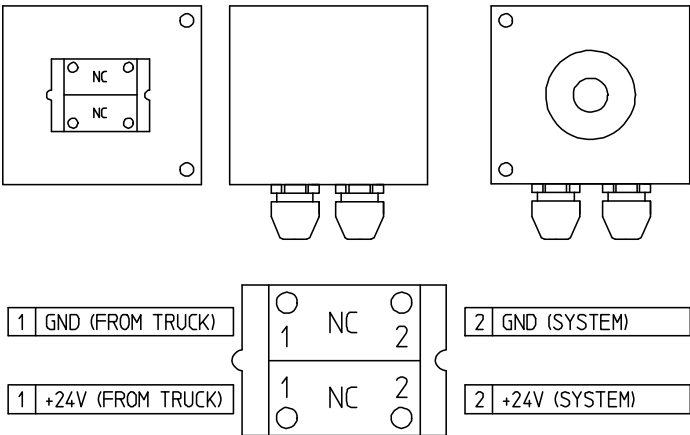

NOTE! CHECK THE POLARITY  
SWITCH 1: TRUCK +24V -> SYSTEM +24V  
SWITCH 2 TRUCK GND -> SYSTEM GND

# Installation

Ultima Hooklift

01/2020

## 111694002 Stop button, outside

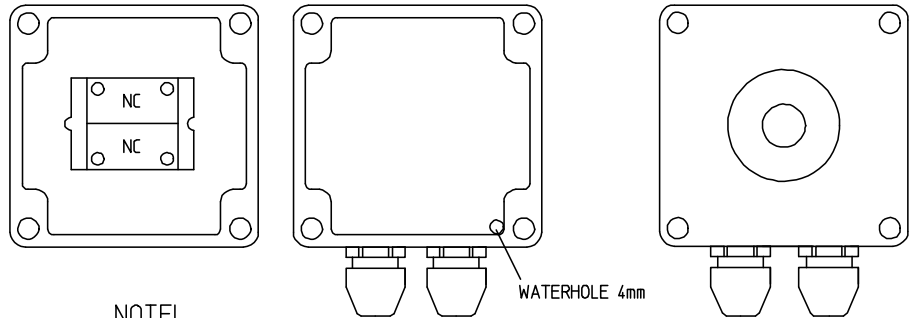

NOTE!  
WHEN MOUNTING OUTSIDE,  
THE CABLE GLANDS SHOULD POINT DOWNWARDS!

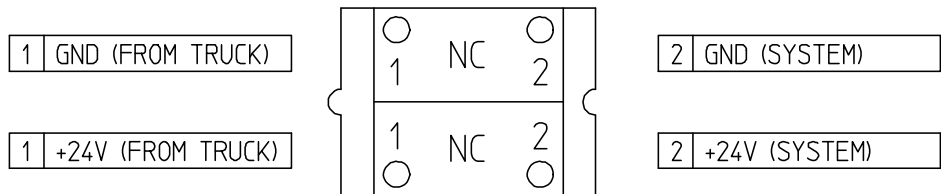

NOTE! CHECK THE POLARITY  
SWITCH 1: TRUCK +24V -> SYSTEM +24V  
SWITCH 2: TRUCK GND -> SYSTEM GND

## 111694003 Emergency stop, outside with memory circuit

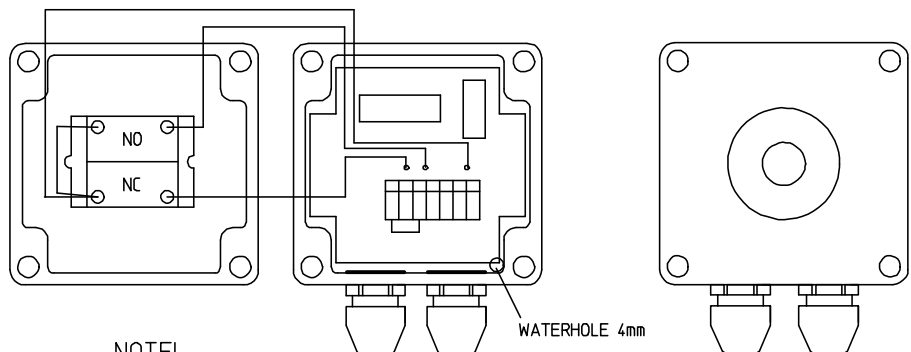

NOTE!  
WHEN MOUNTING OUTSIDE,  
THE CABLE GLANDS SHOULD POINT DOWNWARDS!

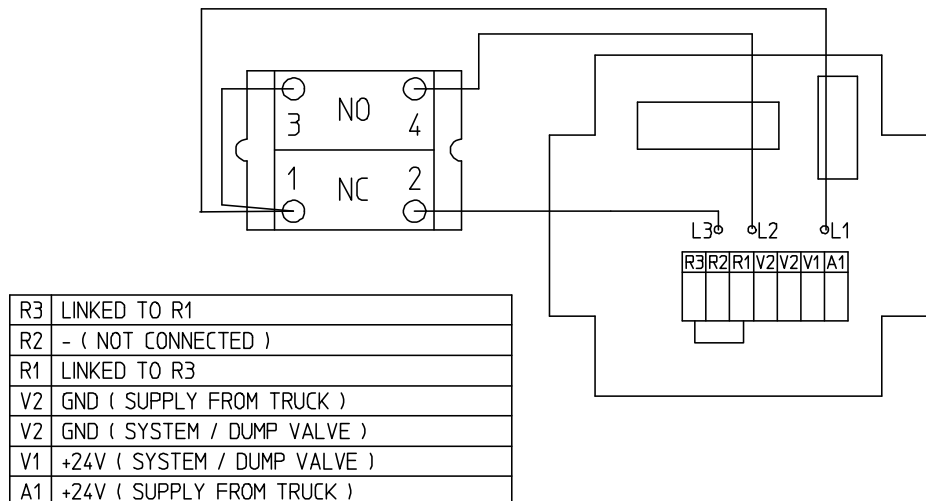

## 6.5 Working lights

Install the relay box near the control valve and the working lights to the connection bridges inside the box. Then connect the JPT connector to the connector 1.21 in the valve harness or in case of helping cylinder is equipped, to connector 2.17 in the extra harness. Now connect the relay box power to the truck power supply behind a fuse 10-15A.

**Note! Max 8 lights totalling 10A.**

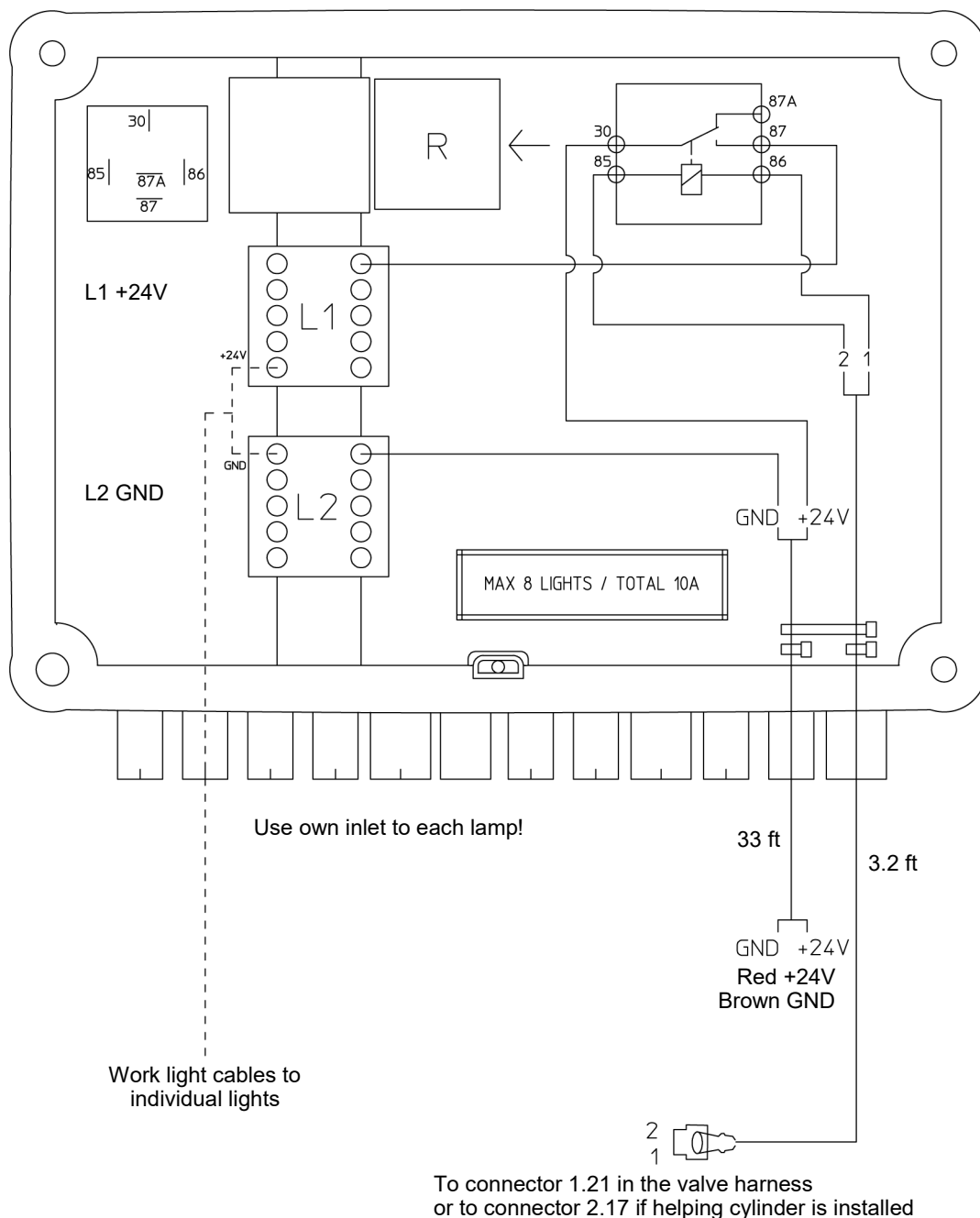

## 6.6 Rear view camera control connections

There are three rear view cameras which are installed to cabin back wall, close to rear rollers and on the rear bumper. The cameras include 65 ft extension cables which are connected to the 8" connections cables and to the camera switch box. The switch box together with the display are to be installed close to each others inside the cabin to a suitable place.

**Note!** Do NOT use the cables included in the camera switch box. Always use only the MULTILIFT cables!

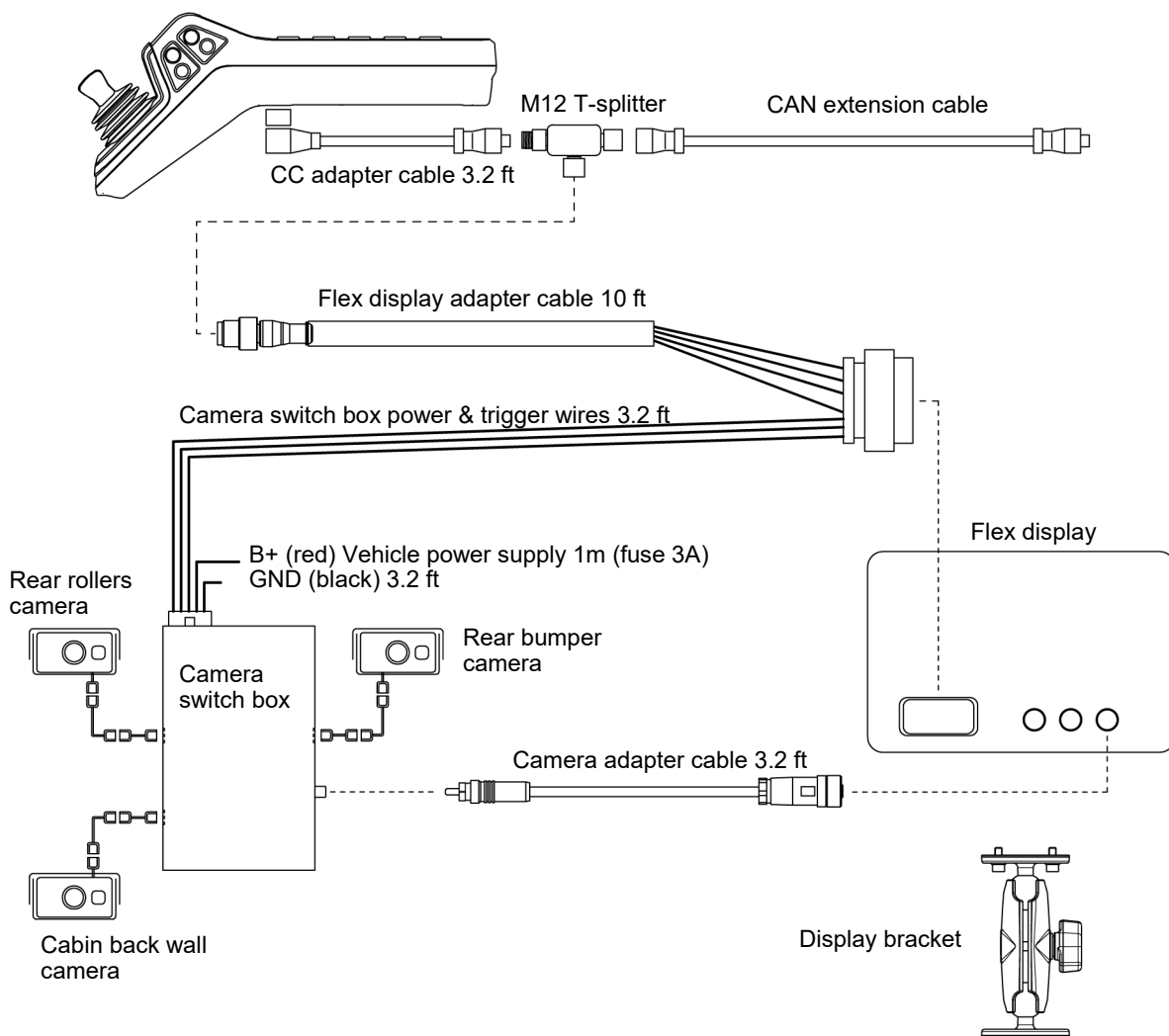

**Read the switch box and camera installation manuals included in the packing box before installation!**

# Installation



Ultima Hooklift

01/2020

## Display adapter cable connections

The display adapter cable is connected to the camera switch box, to the display and to the hooklift control system.

**Note! Do NOT use the cables included in the camera switch box. Always use only the MULTILIFT cable MU113994801!**

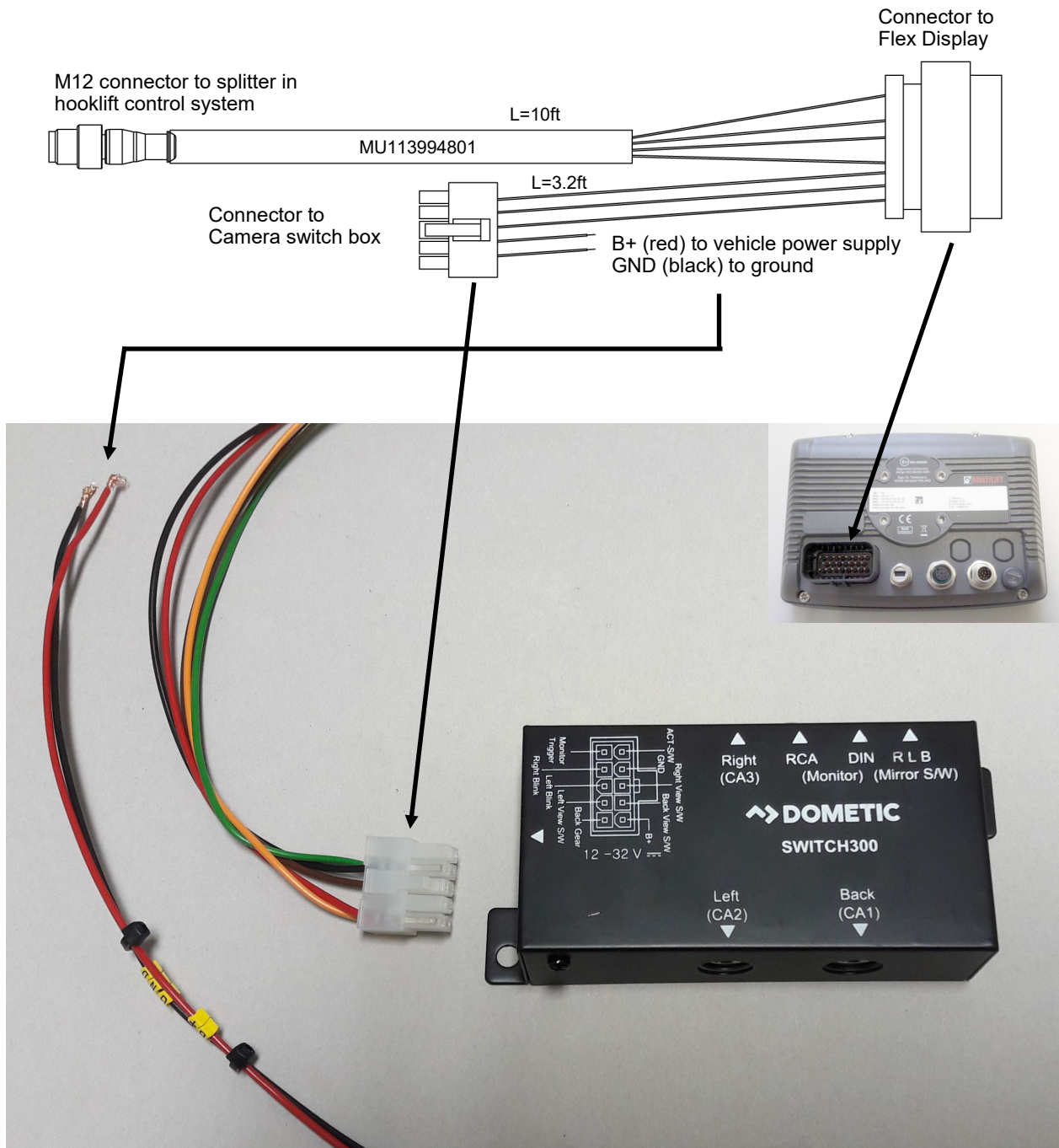

## Camera switch box power connections

Connect the camera switch box power and ground to truck power supply (KL15):

Red wire marked with B+ to truck power supply KL15 (fuse 3A)  
Black wire marked with GND to ground.

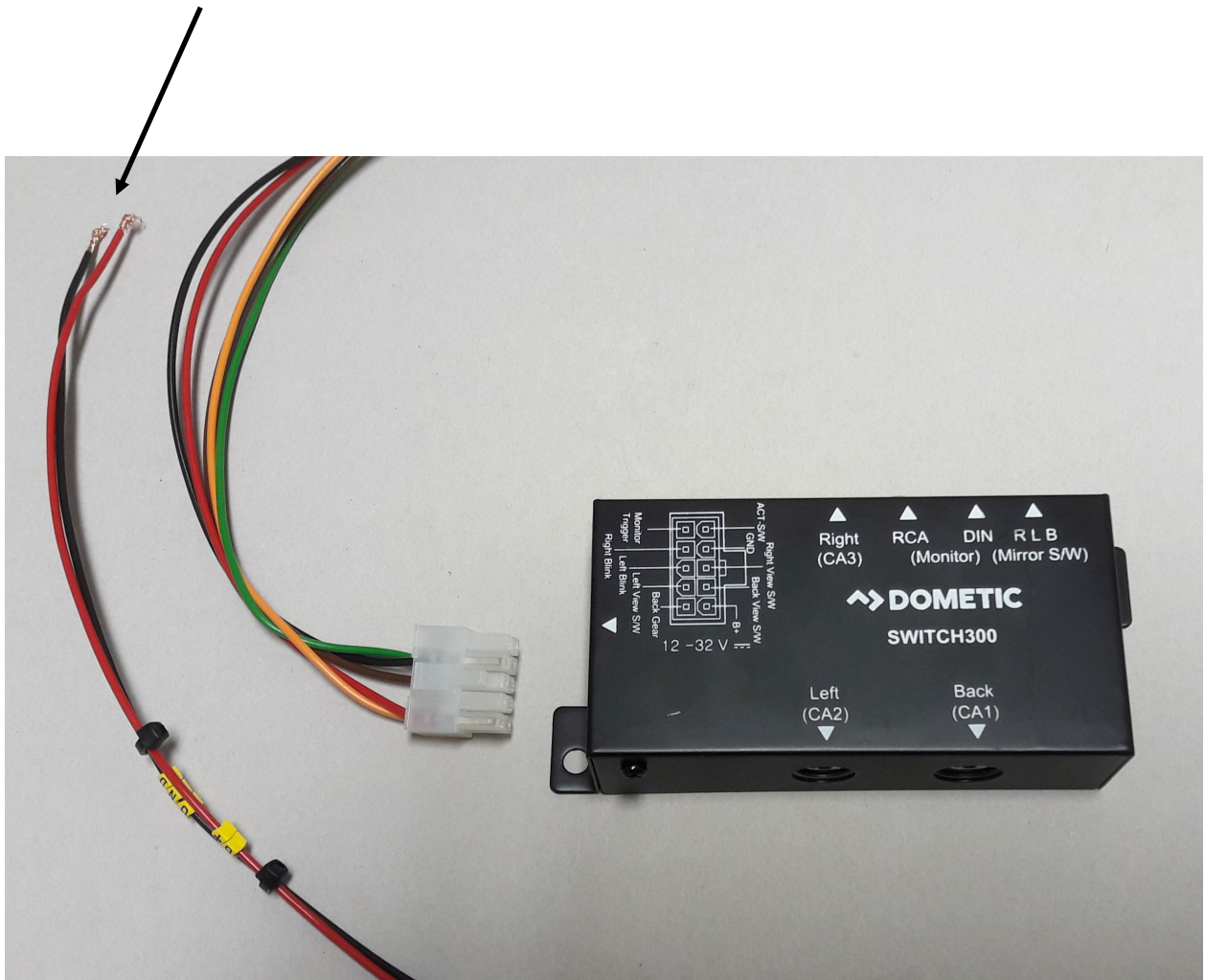

**Read the switch box installation manual included in the packing box before installation!**

# Installation

## Camera and display connections

The cameras are connected to the camera switch box with the 65 ft extension cables and 8" adapter cables as follows:

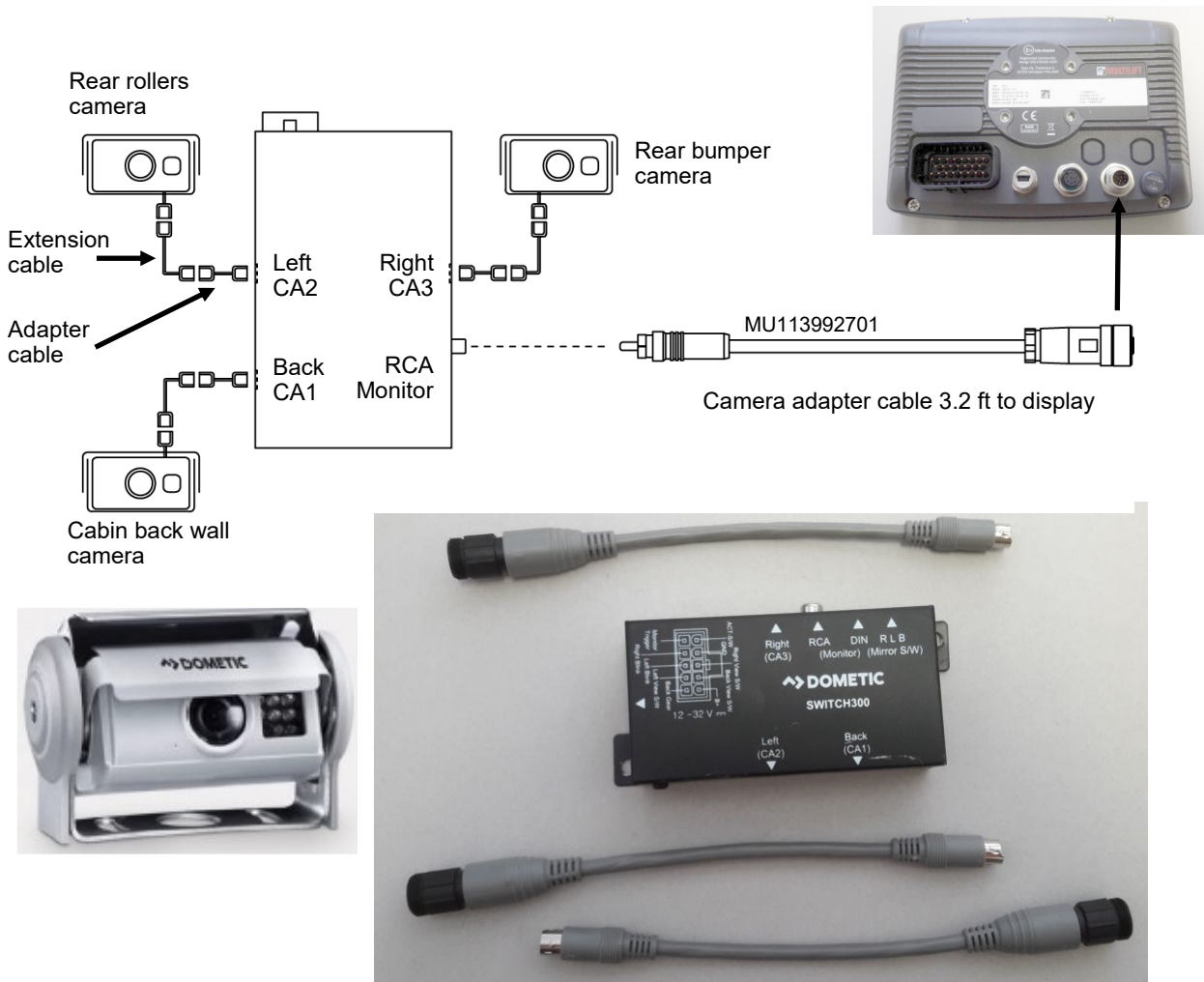

### The camera locations and purpose

**Cabin back wall camera (CA1):** Overview of the environment when reversing the truck.

**Rear rollers camera (CA2):** Showing the roller contact when loading the container. Possible to show also the hydraulic locking:

**Rear bumper camera (CA3):** Detailed view when reversing truck closer to the container and helping when attaching hook to the hookbar. Camera active when middle frame is >100 deg.

**Read the camera installation manual included in the packing box before installation!**

# Installation

## Camera view examples

High

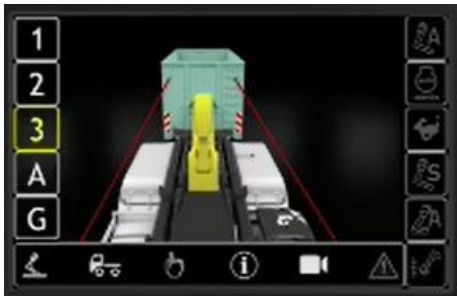

Bogey



Rear





## 6.7 Connectivity gateway antenna

The gateway antenna is delivered loose in the packing box and the antenna bracket is installed in front of the left side subframe beam. Exception is the hooklift with tool console where the antenna is preinstalled in the factory.

**THE ANTENNA SHOULD BE INSTALLED TO A POSITION WHERE VISIBILITY TO THE SKY IS AS GOOD AS POSSIBLE!**

The best place for the antenna is on top and at back of the truck cabin.

The gateway module is installed on the control valve bracket.

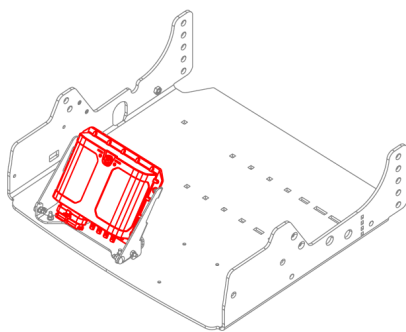

CV side

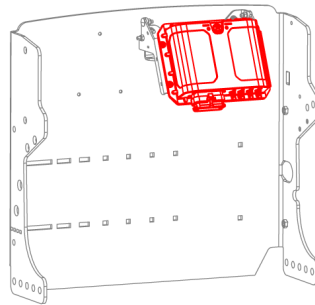

CV front

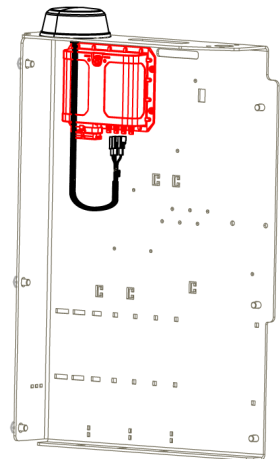

CV tool console

The illustration below is showing the location of the antenna bracket in new hooklift delivery. The correct and suitable location must be checked during the installation, before the connectivity gateway is taken into use.

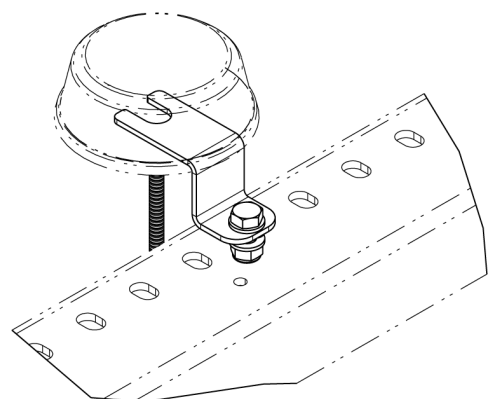
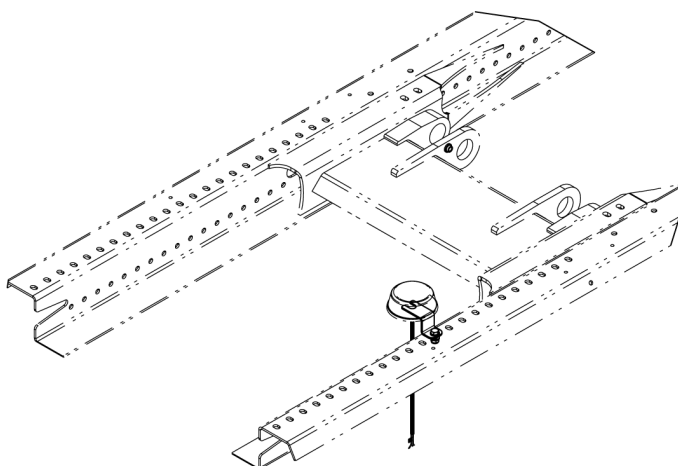

## Antenna and connection cable

The length of the antenna cable depends on the control valve (CV) position and the G-length of the hooklift. For the Ultima hooklifts with G-length  $\geq 61$  there is an extension cable delivered with the unit.

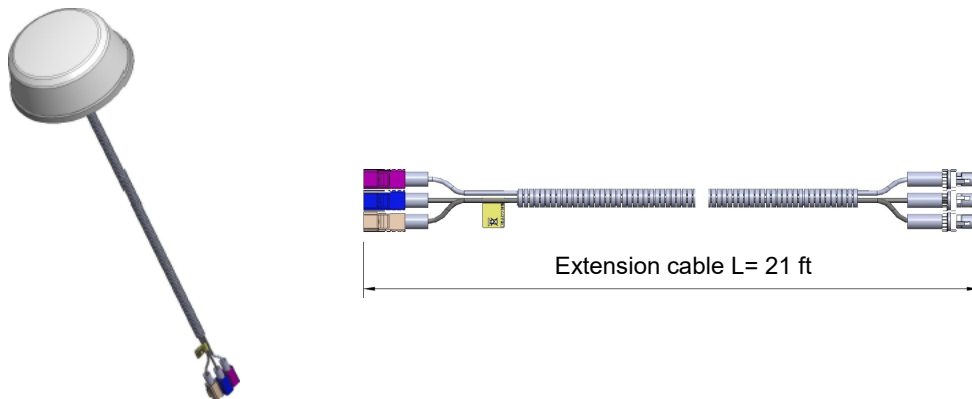

## Antenna and gateway connections

Connect the antenna colour coded connectors and the power feed to the gateway module according to the drawing below.

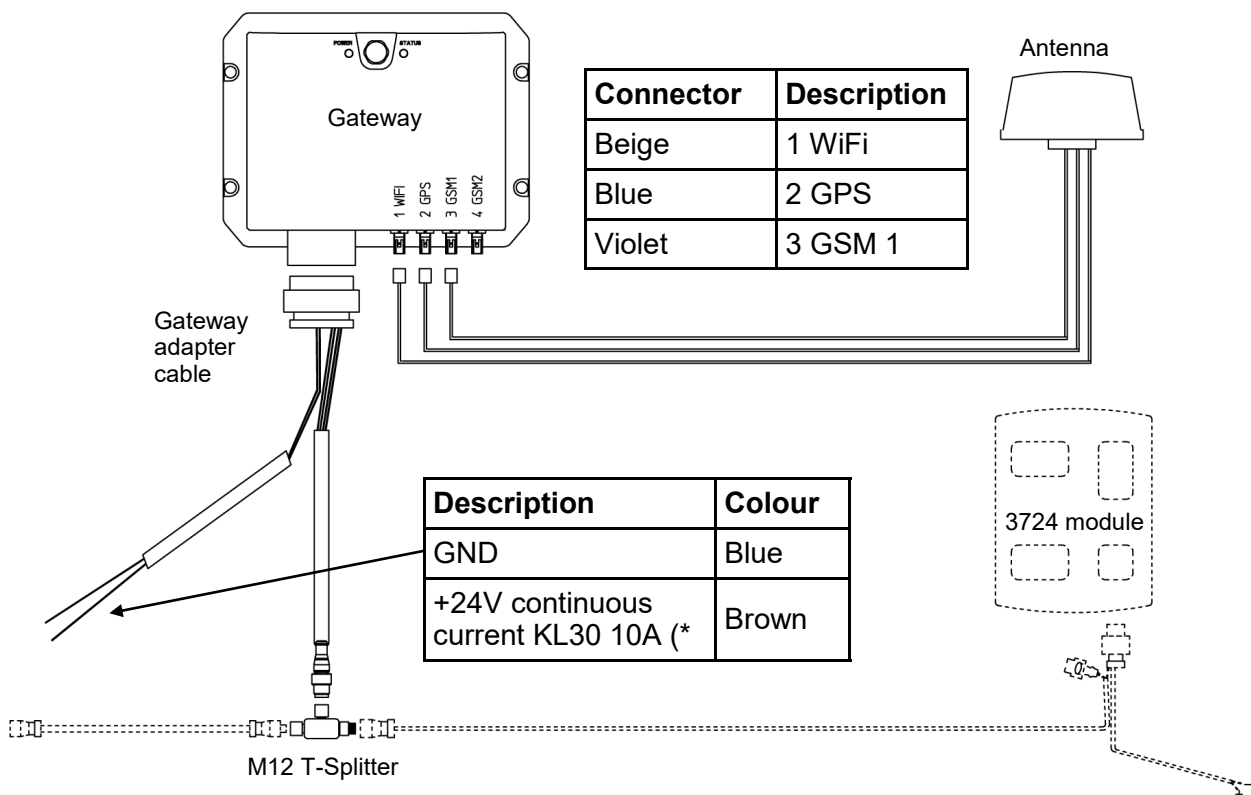

\*) The gateway has 7A internal fuse but it is recommended to connect the power supply to the truck 10A fuse.

## 7 Testing the hooklift

### 7.1 safety precautions when testing the hooklift

Always use personal safety protections when testing the hooklift.

High pressure oil leaks can be life threatening, especially direct sprays of oil. Never touch the hydraulic components under pressure and therefore stay clear from the hydraulic system.

All hydraulic leaks must be repaired immediately when noticed. Before repair make sure that there is no pressure in the system and none of the frames can move during the repair.

If two or more persons are involved in testing and checking, they should always agree actions before starting to use the hooklift.

Make sure that there is sufficient free space around and above the hooklift to perform all operations and that there is no-one near or liable to approach the hooklift during testing. Make sure that you have read the operator's manual and safety instructions before testing.

Controlling the hooklift directly from the valve spools is only permitted if carried out by trained personnel.

Always vent and fill the pump with oil before starting. Check pump manufacturer's instructions.

The first test run must be performed with extra care because there is air in the system which may cause unexpected movements. Observe all movements carefully to prevent any damage, possible collisions or friction of parts.

Make sure you keep out of range of all rotating or moving parts such as frames, container locks, under run bar etc.

### 7.2 Testing the hooklift

The proximity switches (sensors) of the control system are preventing or allowing the movements of the hooklift frames and all of these functions must be tested. One or more sensors might have moved or damaged during the transport, lifting or installation and therefore all sensors must be checked at first visually before testing the safety functions.

All functions of the hooklift should first be performed several times without container. Bleed the air from the system by moving all cylinders in and out 4 - 5 times and keeping the cylinders pressurized about 5 seconds. Note: Main cylinders in and hydraulic body locks can't be kept pressurized because of the safety system.

Check the oil level in the oil tank and fill up if necessary. Check also for possible oil leaks.

# Installation



Ultima Hooklift

01/2020

With the truck engine idling check the setting of the by-pass valve by checking to see that the container locks are opening and closing without a delay and that the hook arm is moving front and back. If the locks or hook arm (as well as any of accessories) are not moving, close the by-pass valve to increase flow to the hydraulic actuators. The standard factory setting of the by-pass valve is half open. The adjustment range of the valve is 4 - 10 gal/min.

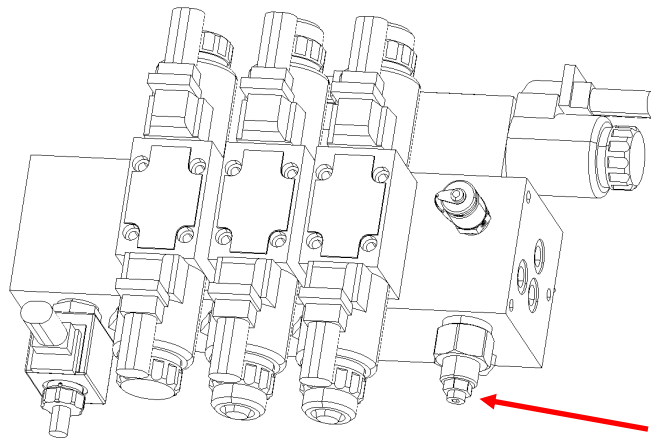

**Ultima BASE only!**

By-pass valve adjustment:  
-Turn clockwise to reduce the speed  
--Turn counter clockwise to increase the speed

The safety functions of the hooklift are the following:

- The hydraulic body locks must not open while tipping up (lift up only about 2 ft).
- The hydraulic body locks must not close when middle frame is up and rear frame is down.
- The hook arm does not move back or front when the hydraulic body locks are closed.  
NOTE: Hook arm can be moved front if the function "Sliding While Tipping" is set on. If also movement back is allowed, then check the operation of the ultrasonic sensors.
- End damping/floating function will start about 8" - 12" before the middle frame is down.
- The warning buzzer sounds during all hydraulic movements.

## Accessories:

- When the hydraulic or manual front locks are closed, the main cylinders don't move out and the hook arm does not move rear or front.
- Tipping is not allowed if while the "Crane body on" sensor is active.
- The main cylinders protection circuit is limiting the operation pressure of main cylinder out movement to 1600 psi after middle frame is lifted up over 20° angle.
- When the adjustable under run bar is out, the main cylinders don't move out.  
NOTE: If the hydraulic or electric operated under run bar is set to automatic or semi-automatic function, then the under run bar moves in when the main cylinders are moved out.
- The fast speed tipping goes off after tipping angle exceeds 40°.
- The automatic lowering will stop if the control lever (joystick) is moved.
- When an additional control unit (Crane top seat control or radio controller) is switched on, the Cabin controller unit screen will have "-C2-" in the display.
- Check also the safe operations of other possible accessories.

Check the operation of the hooklift also with a loaded container and known test load.

After the unit has passed the tests fill in the test report and write down any possible notes and deviations.

## 8. Finishing the installation

Protect all electric connections and check the greasing points.

Finish all welding and surfaces of the cut plate edges.

Clean all excess lubricants and remove all welding sparks and protection agents.

Wash the hooklift and other components thoroughly before touch-up painting.

As standard the hooklift is delivered from factory painted with 100 µm single layer polyurethane top coat according to standard PUR 100/1 FeSa 2½. As an option the main frames are primer painted with zinc primer before top coating according to standard EPZn@PUR 140/2 FeSa 2½.

Repair all possible damages in the painted surface immediately to avoid any corrosion:

Protect the surrounding area and clean the damaged area thoroughly from impurities and old paint to clean steel surface. Smoothen the paint edges carefully. Check that the surface is clean from dust, oil and grease and completely dry for the touch-up. Paint it with 100 µm layer, use of primer is not recommended. Use acrylic paint with correct colour, check the tone and code (RAL) carefully before painting. Let the paint dry 24 h indoors.

Check the correct colour from the hooklift order before touch-up painting.

If any accessories are installed afterwards to the hooklift frames, then use protective wax between the components.

NOTE! It is not allowed to paint the I/O module, radio receiver and gateway module.

## 9. User training

User training and service instructions must be given to the operators of the hooklift. Stress the need to observe safety rules during operation.

Check that all required documents are made and filled as well as the operator's manual is available for the user.

**Remember to fill the delivery card in C-Care to ensure that the product warranty takes effect. Print a copy also to the customer.**

# Installation



Ultima Hooklift

01/2020

---