



COLOR:101 - PHOENIX RED

Brakes

HYDRAULIC

DISC

Speed

1 X 12

Fork

AIR / 100 MM

REMOTE CONTROL

R/derailleur

SHIMANO

DEORE XT

Technical details

Body

- **Frame** Cyclision one, Alutec, Tapered, Boost, Weight 2200 g
- **Fork** SRAM, Recon RL, Boost Rockshox, 100mm, Axle solo air, Remote Speed Lockout
- **Head parts** Neco, Semi-integrated, H159 M
- **B.B. parts** SHIMANO SM-BB52

Dynamics

- **Crankset** SHIMANO DEORE XT, FC-M8100-1, 34T, 175 mm
- **Chain** SHIMANO CN-M6100
- **R/derailleur** SHIMANO DEORE RD-M8100 XT
- **Shifters** SHIMANO, SLX, SL-M7000
- **Brake levers** SHIMANO, BL-M6100
- **Brakes** SHIMANO, BR-M6100
- **Brake rotors** SHIMANO, SM-RT30, R-160mm, F-180mm, Center Lock

Wheels

- **Sprocket** SHIMANO, DEORE, CS-M6100-12, 12-SPEED, 10-51T
- **Hubs** SHIMANO, Front-HB-MT400-B, Rear-FH-MT410-B, 32 holes, Center Lock
- **Tires** MAXXIS, Crossmax M309P
- **Rims** REMERX, Alloy , Double layer, 32 holes, With Eylets

Comfort

- **Saddle** Cyclision one, 100% Polyurethane, Memory Foam, Double Density, LADY
- **Seat post** Cyclision one, diam 30.9mm, lenght: XL/L/M 350mm; S/XS 300mm
- **Grips** Cyclision one, with Lock on
- **Pedals** Plastic 3
- **Handlebar** Cyclision one, Alloy Rise, diam 31.8mm, rise 25mm, width: XL/L/M 720mm; S 700mm
- **Stem** Cyclision one, diam 28.6mm, bar bore 31.8mm, lenght 70mm

Body



Frame

Cyclision one, Alutec, Tapered, Boost, Weight 2200 g

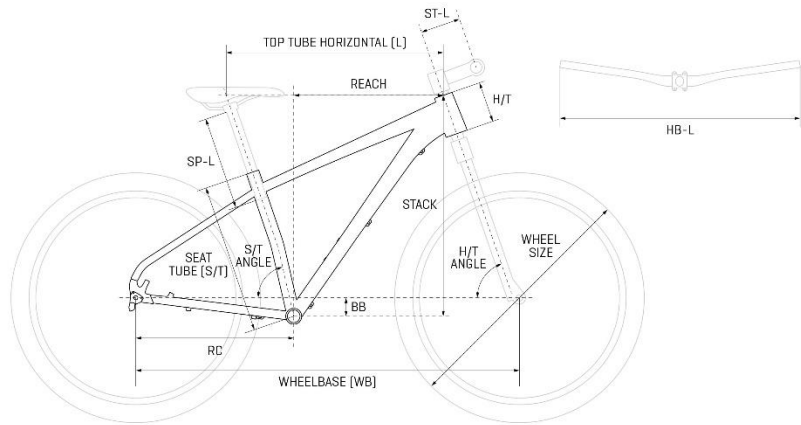
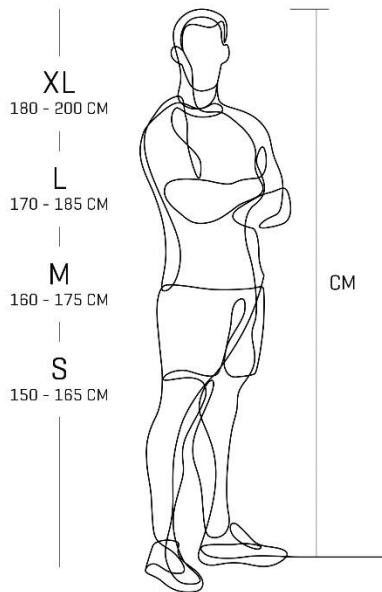

Size	Wheel Size	S/T (inch/mm)	L (mm)	Reach (mm)	Stack (mm)	H/T (mm)	S/T angle	H/T angle	BB (mm)	RC (mm)	WB (mm)	HB-L (mm)	ST-L (mm)	SP-L (mm)
S	27.5"	16"/405	581	399	597	110	77°	71°	50	430	1055	700	70	300
M	29er	17"/430	594	405	617	105	77°	71°	55	440	1084	720	70	350
L	29er	19"/480	612	422	622	110	77°	71°	55	440	1094	720	70	350
XL	29er	21"/530	613	423	627	115	77°	71°	55	440	1103	720	70	350

Made sizes and usability

MK2 - c1-2



Fork
SRAM, Recon RL, Boost Rockshox, 100mm, Axle solo air, Remote Speed Lockout



Head parts

Neco, Semi-integrated, H159 M



B.B. parts
SHIMANO SM-BB52

Dynamics



Crankset

SHIMANO DEORE XT, FC-M8100-1, 34T, 175 mm



Chain
SHIMANO CN-M6100



R/derailleur
SHIMANO DEORE RD-M8100 XT



Shifters

SHIMANO, SLX, SL-M7000



Brake levers
SHIMANO, BL-M6100



Brakes

SHIMANO, BR-M6100



Brake rotors
SHIMANO, SM-RT30, R-160mm, F-180mm, Center Lock

Wheels



Sprocket
SHIMANO, DEORE, CS-M6100-12, 12-SPEED, 10-51T



Hubs

SHIMANO, Front-HB-MT400-B, Rear-FH-MT410-B, 32 holes, Center Lock



Tires
MAXXIS, Crossmax M309P



Rims

REMERX, Alloy , Double layer, 32 holes, With Eylets

Comfort



Saddle

Cyclision one, 100% Polyurethane, Memory Foam, Double Density, LADY



Seat post

Cyclision one, diam 30.9mm, lenght: XL/L/M 350mm; S/XS 300mm



Grips
Cyclision one, with Lock on



Pedals

Plastic 3



Handlebar

Cyclision one, Alloy Rise, diam 31.8mm, rise 25mm, width: XL/L/M 720mm; S 700mm



Stem

Cyclision one, diam 28.6mm, bar bore 31.8mm, lenght 70mm

The manufacturer has the right to change product specifications, equipment, models, colors and materials.