



by Tanis Technologies LLC

## Operating Instructions & Parts Manual

### **READ AND SAVE THESE INSTRUCTIONS**

**WARNING – TO REDUCE THE RISK OF FIRE, ELECTRIC SHOCK, OR INJURY TO PERSONS, OBSERVE THE FOLLOWING:**

A) Use this unit only in the manner intended by the manufacturer. If you have questions, contact the manufacturer.

B) Before servicing or cleaning unit, switch power off at service panel and lock the service disconnecting means to prevent power from being switched on accidentally. When the service disconnecting means cannot be locked, securely fasten a prominent warning device, such as a tag, to the service panel.

**Read carefully before attempting to assemble, install, operate or maintain the product described. Protect yourself and others by observing all safety information. Failure to comply could result in personal injury and/or property damage. Retain instructions for future reference.**

# MODULE-AIR AF03M1220 and AF07M1220 Coolant Mist Collector

## Description

This Coolant Mist Collector by Module Air is designed to remove mist from inside an enclosed machining center.

The collector pulls the mist into its coalescing filter and removes the liquid from the air. Once the liquid is removed the air enters a 95% bag filter where particles are removed, then finally the air passes through an activated charcoal filter to remove light gases and odors.

The unit is easily mounted on top of any machining center (follow directions on page 4) In most cases, mount the adaptor on the machine with caulk and bolts, then mount the unit on top either vertically or horizontally. The unit can also be suspended above the machine and connected to the machine tool thru the use of a hose.

**The AF071110 will deliver up to 2000 CFM and weighs 135lbs, ¾hp, 220 volt, 5.1 amps**

**The AF031110 will deliver up to 1000 CFM and weighs 100lbs ½hp 220 volt 4.4 amps**

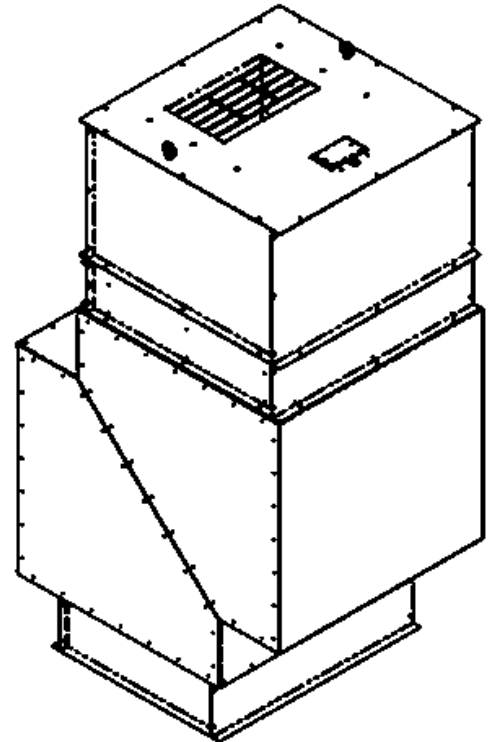

## Unpacking

The machine should arrive on a skid with the filters already installed. There will also be an adaptor assembly and a package of bolts. Carefully remove the wrappings and banding that have been securing the unit to the pallet.

## Operation

The Coolant Mist Collector should be wired to a 220 power supply by a licensed electrician according to your local codes. Once installed using the instructions on page 4, your Coolant Mist Collector by Module-Air can be operated with the flip of a switch. The Coolant Mist Collector is designed to run continuously while the machine is in use. There is no need for a door switch.

## Maintenance

Follow these precautions when performing maintenance on the motor or blower.

1. Turn off motor, and LOCK OUT electrical service to the unit.
2. LOCK OUT even when changing filters.
3. Change filters regularly to maintain optimum performance. If the performance of your air cleaners appears to be declining try replacing the filters.
4. Be sure that replacement filters are always rated for the correct CFM and air flow.

### If the system requires maintenance exceeding filter change, read below...

Disconnect the Power Source. Remove the top panel by removing the 3/8 hex fasteners and eyebolts. The blower/motor assembly is attached to the top panel and will be VERY HEAVY and usually requires at least 2 people. Remove this panel by taking the necessary precautions regarding your safety.

## Troubleshooting Chart:

Symptom	Possible Cause(s)	Corrective Action
No air is coming out the exhaust port.	Filter is loaded with debris.	Turn unit off, lock out power to unit, then replace the bag filter: remove the clamps on the coalescing filter, remove the coalescing filter and remove the bag filter.
Filters have a short life.	The bag filter may not be seated properly	Reach in each pocket to make sure fabric is not between filter stop and filter frame
Oil is coming out of the top	The bag filter may not be seated properly	Reach in each pocket to make sure fabric is not between filter stop and filter frame
Blower does not turn but there is a humming sound	Capacitor has expired	Purchase a new capacitor from your Grainger store. Part number is listed on the installed capacitor.
Other		Call the manufacturer at 616.990.8005

## General Safety information SAFETY GUIDELINES- DEFINITIONS

This manual contains information that important for you to know and understand. This information relates to protecting YOUR SAFETY and PREVENTING EQUIPMENT PROBLEMS.

### GENERAL SAFETY RULES

#### **!WARNING!**

This machine was designed for certain applications only. Tanis Technologies LLC strongly recommends that this machine not be modified and/or used for any application other than that for which it was designed. If you have any questions relative to a particular application, DO NOT use the machine until you have first contacted Tanis Technologies LLC and confirmed that the product is suited for your application.

#### **!WARNING!**

**Failure to follow these rules may result in serious personal injury.**

**1. For your safety, read and understand the instruction manual before operating the unit.** Learn the unit's application and limitations as well as the specific hazards, related to it.

**2. Don't use in dangerous environments.**

Don't use this unit in damp or wet locations or expose to rain.

**3. Disconnect unit** before servicing.

**4. Check damaged parts** before

future use of the unit, properly repair or replace any part that is damaged.

#### **!WARNING!**

5. Avoid mixing combustible Materials like (but not limited to) the following: buffing lint, paper/wood dust, aluminum or magnesium with dust generated from the grinding of ferrous materials. This creates a potential for fires due to the mixing of sparks and combustible materials.

6. A machine operator should NEVER be allowed to put lit cigarettes or any burning object into this or any dust control system.

7. If there is a chance for heated and/or flammable materials to enter the unit, installation of the unit should be evaluated to determine if a fire protection/exhaustion systems should be installed. Federal, State or local codes, as required by organizations such as NFPA and Factory Mutual Insurance or your insurance carrier may require such a system. **Module-Air can offer basic guidelines for such an installation: however, final installation design is the responsibility of the purchaser.**

8. Securely anchor unit to a permanent or fixed supporting structure, be sure the structure is rated to hold the weight of the unit.

9. Support this unit or clamp it to the work surface when using it in a portable application to eliminate potential injury or damage to the

unit

10. Ensure that the intake and exhaust areas are clear prior to starting the unit. Clogged intakes or exhaust can cause explosion and/or fire.

11. Keep arms and fingers away from fan. Avoid all exposure to rotating parts to prevent injury.

12. Do not attempt to remove/replace filters while unit is running. Fan blades can cause severe cuts. Be sure the unit is disconnected from power source.

13. Maintain the unit in top condition. Clogged filters can increase potential for fire or explosion. Follow instructions for changing filters.

14. Turn the unit "off" and disconnect power source before installing or removing accessories, before adjusting or changing set-ups or when making repairs. An accidental start up can cause serious injury.

15. The Coolant Mist Collector units are made to run continuously, check the filters regularly for built-up debris. Frequency of filter changes will depend upon the environment in which the unit is running.

16. To maintain warranty, be sure to use only filters that are approved by the manufacturer.

**INSTALLATION AND PREPARATION BEFORE OPERATING:**

**Disclaimer:**

Although instructions and recommendations are included for installation of your Coolant Mist Collector by Module-Air, the manufacturer does not assume responsibility for the installation of this equipment nor shall be held liable for direct or consequential damages resulting from improper methods, structural failure or inadequate supports.

**INSTALLATION: (Diagram below)**

The following are basic guidelines and considered suggestive. A

professional installer should be consulted.

There are four eyebolts in the exhaust end of the unit. These are meant for hoisting the unit into position or suspending the unit near the machine in a vertical position using the proper chain and safety links (not provided).

Two of the eyebolts can be located on the opposite end of the unit so as to facilitate a horizontal mount. A more secure method may be to use threaded rod and UNI-STRUT. The UNI-STRUT is placed top and bottom as shown in the illustration. The nuts are placed under the bottom struts and above the top struts and

tightened against each other to clamp the unit between them. The threaded rod is secured to solid building structure or beams near the ceiling that are rated for such a load.

The UNI-STRUT rails are not included, but are available at GRAINGER or McMaster Carr.com

**Once again the instructions here are only suggestion** and a professional installer should be consulted, Module-air and Tanis Technologies LLC will not be held liable for improper installation, or injuries, or damages caused by an improper installation.

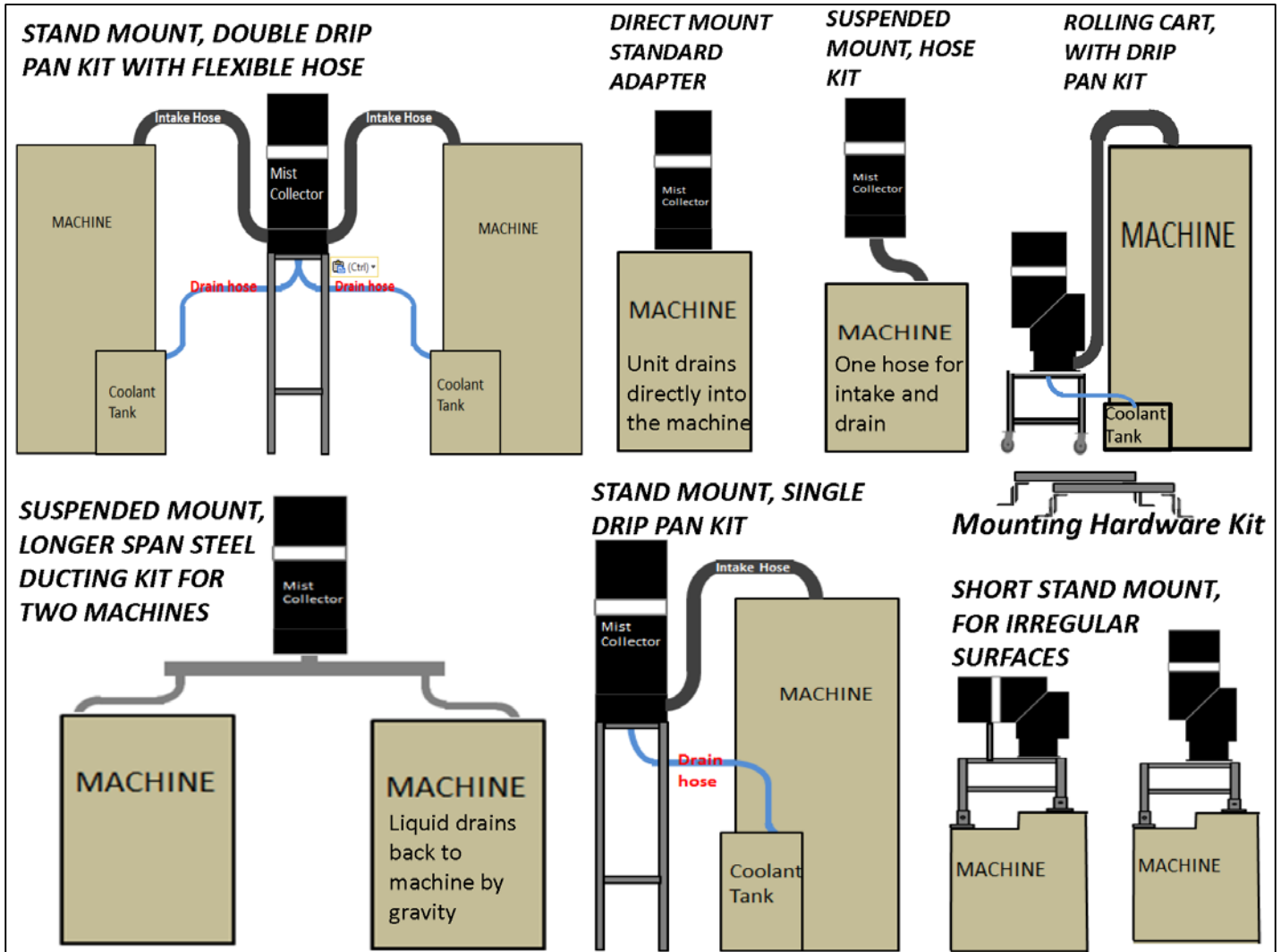

# Wiring Diagram for AF03M1110

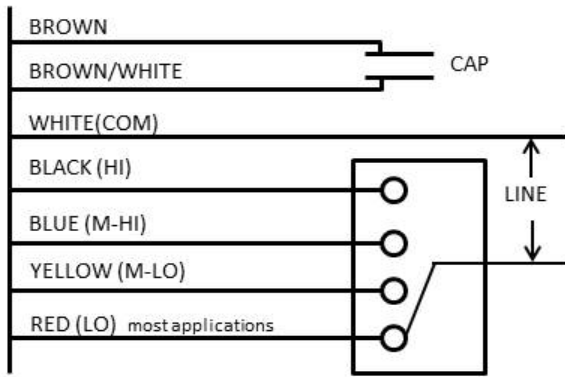

ROTATION

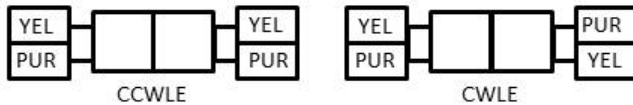

ATTENTION INSTALLER, THIS ADDITIONAL CONNECTION DIAGRAM IS BEING SUPPLIED FOR YOUR CONVENIENCE

THE WIRING DIAGRAM SHOWS THE SPEED SELECTION WIRE COLORS FOR THE 4 SPEED MOTOR.

1. RED WIRE= 1000 RPM, 600 CFM@0.5WC
2. YELLOW WIRE= 1126 RPM, 720 CFM@0.5WC
3. BLUE WIRE= 1252 RPM, 835 CFM@0.5WC
4. BLACK WIRE= 1380 RPM, 1000 CFM@0.5WC

THE CURRENT RPM IS SET AT 1000

THE MAXIMUM VACUUM AT #1 RPM (RED) IS 1.4WC@250CFM

THE MAXIMUM VACUUM AT #4 (BLACK) RPM IS 1.8WC@450CFM

NORMAL RUNNING AMPS ARE APPROX. 6.4A  
9.8 FLA

TOTAL AMPS AT STARTUP 21A



# Wiring Diagram for AF07M1110

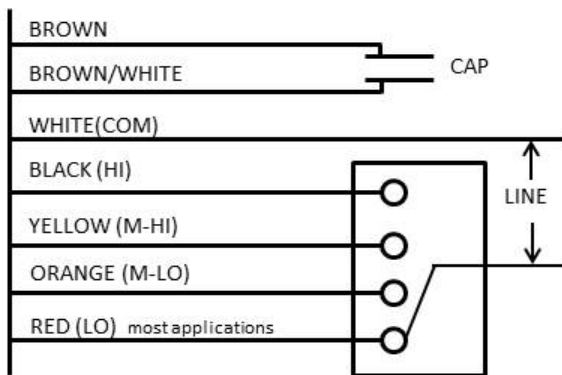

ROTATION

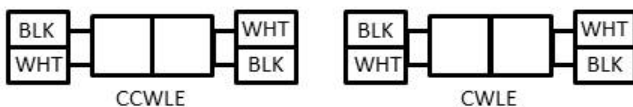

ATTENTION INSTALLER, THIS ADDITIONAL CONNECTION DIAGRAM IS BEING SUPPLIED FOR YOUR CONVENIENCE

THE WIRING DIAGRAM SHOWS THE SPEED SELECTION WIRE COLORS FOR THE 4 SPEED MOTOR.

1. RED WIRE= 1000 RPM, 1600 CFM@0.5WC
2. YELLOW WIRE= 1126 RPM, 1720 CFM@0.5WC
3. BLUE WIRE= 1252 RPM, 1835 CFM@0.5WC
4. BLACK WIRE= 1380 RPM, 2000 CFM@0.5WC

THE CURRENT RPM IS SET AT 1000

THE MAXIMUM VACUUM AT #1 RPM (RED) IS 1.4WC@900CFM

THE MAXIMUM VACUUM AT #4 (BLACK) RPM IS 1.8WC@1250CFM

NORMAL RUNNING AMPS ARE APPROX. 6.4A  
9.8 FLA

TOTAL AMPS AT STARTUP 21A



## Installation for AF03M1110

The coolant mist collector can fit on any machining center. All you need is a hole in the top of the machine and an adapter to bolt on top. This adapter comes with the unit and works for many machines, however some machines need a little more help. At Module-air we are ready to assist you.

Call 616-990-8005

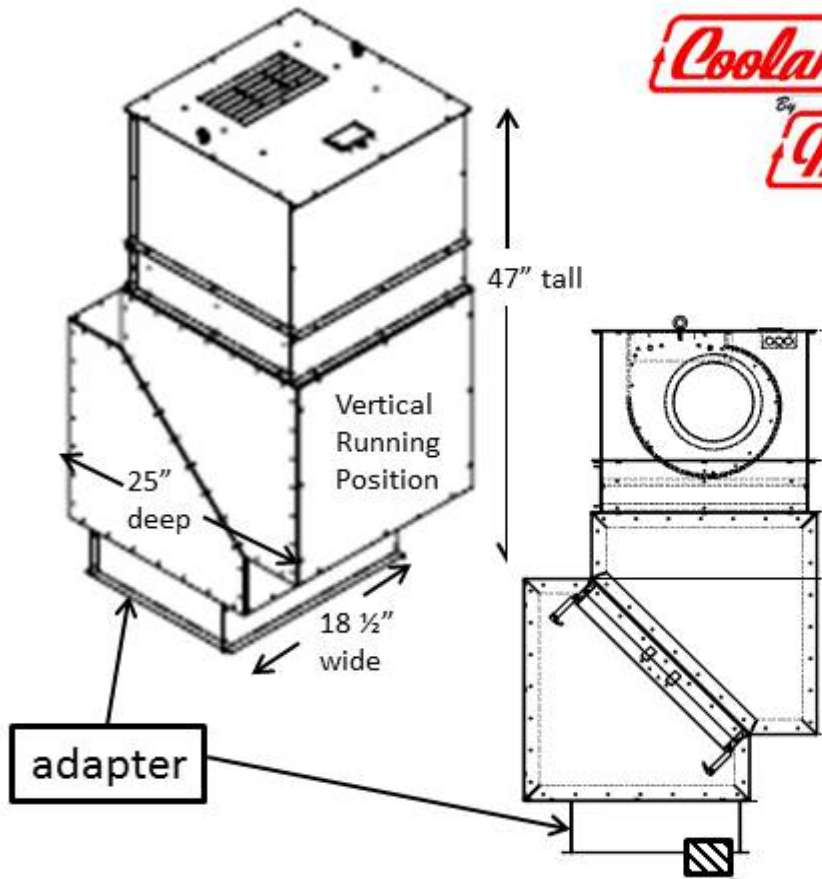

Once the adapter is fixed to the machine, caulk the seam and fasten the unit to the adapter using the 12 bolt pattern on the bottom of the unit with 1/4 - 20 bolts

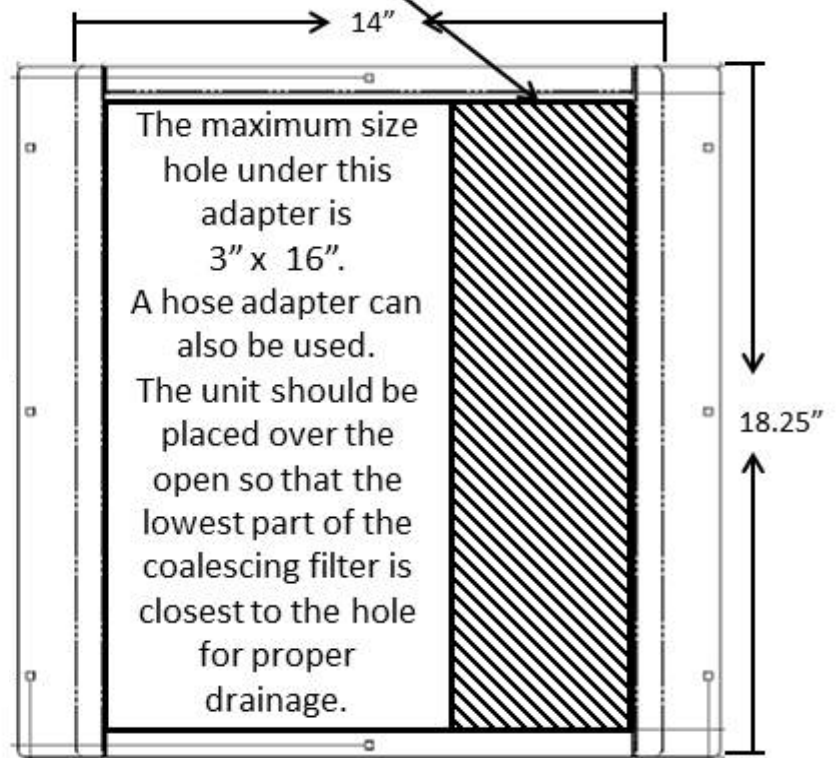

## Installation for AF07M1110

The coolant mist collector can fit on any machining center. All you need is a hole in the top of the machine and an adapter to bolt on top. This adapter comes with the unit and works for many machines, however some machines need a little more help. At Module-Air we are ready to assist you. Call 616-990-8005

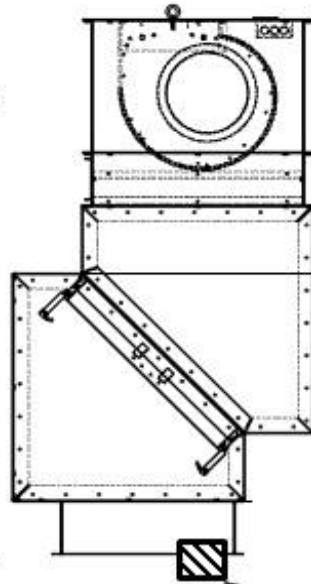
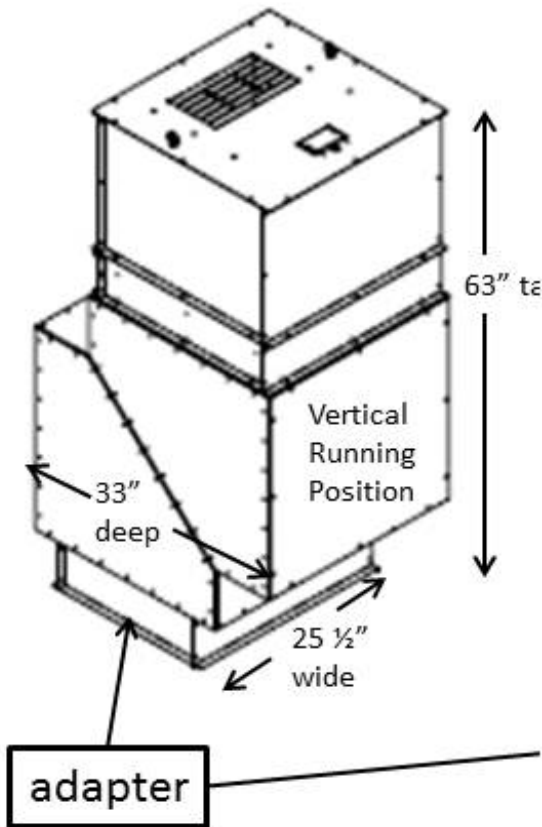

Once the adapter is secured to the machine, caulk the seam and fasten the unit to the adapter using the 12 bolt pattern on the bottom of the unit with 1/4 -20 bolts

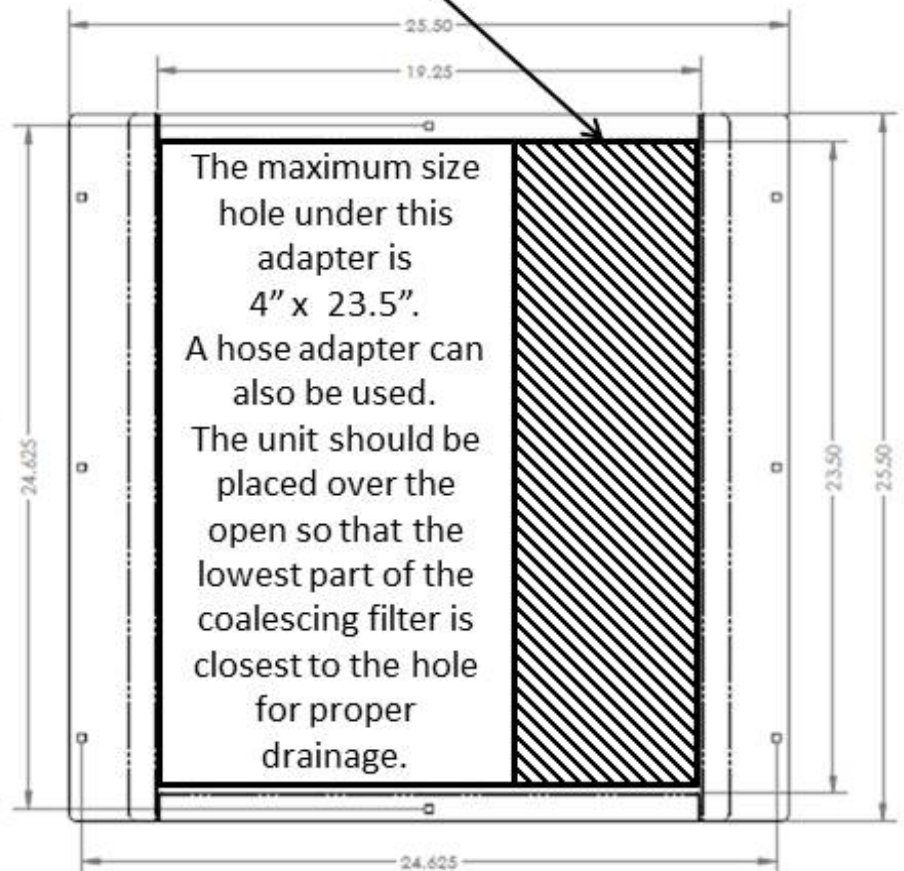

Turn the unit off and install the bag filter. Make sure the filter fabric does not become pinched in the seal area. Push the filter in until captured by filter clips. Failure to remove pinched fabric will result in saturated filters.

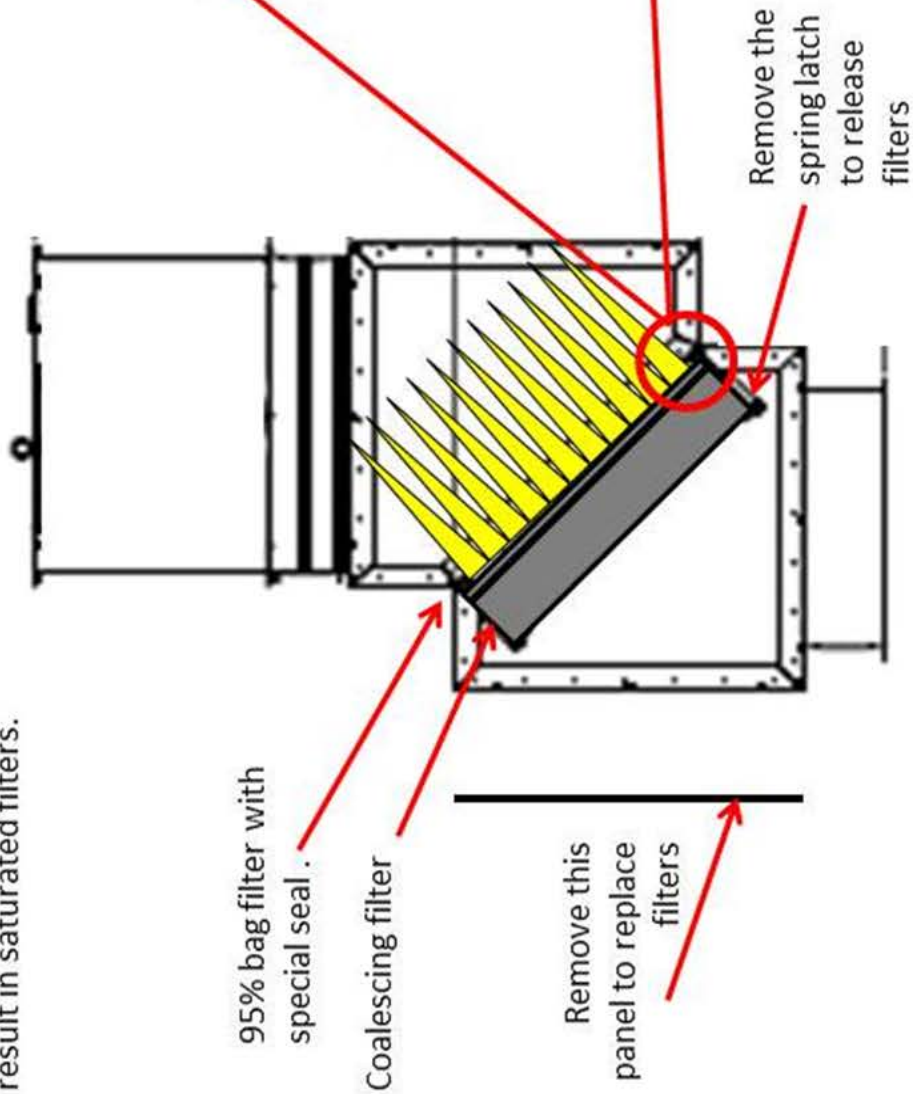
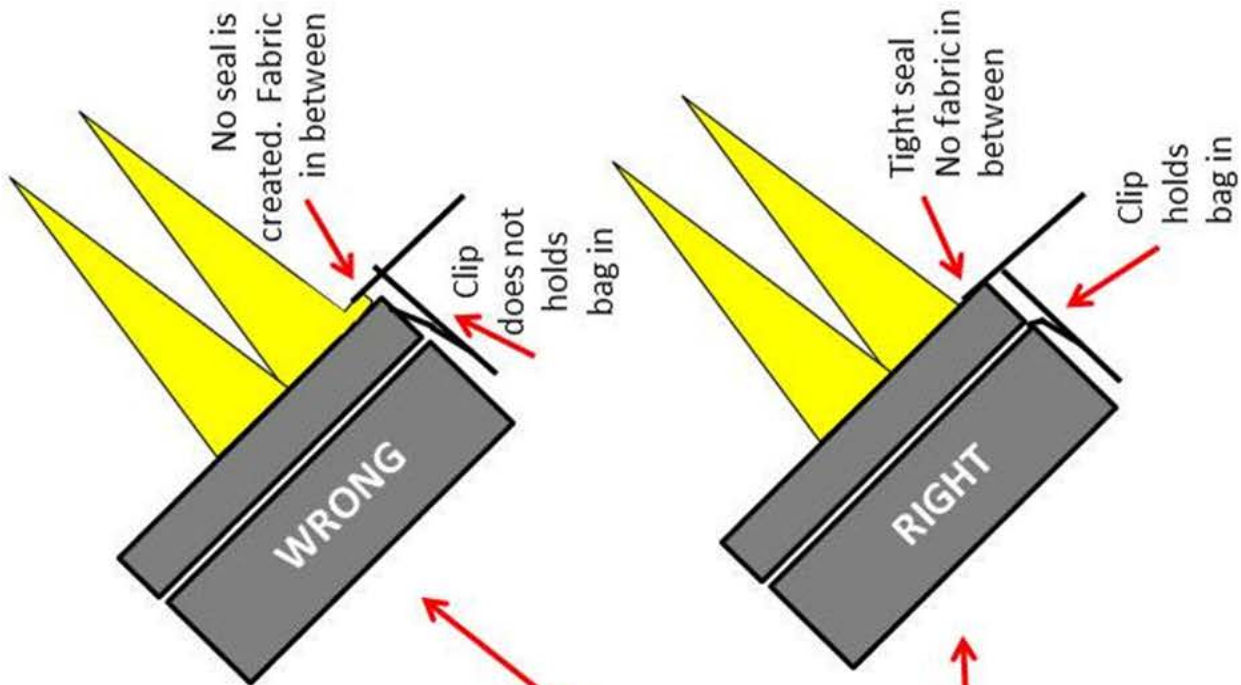



ITEM NO.	QTY	PART NO.	DESCRIPTION
1	1	M07-01	SHORT HOUSING ASSEMBLY
2	1	M07-02	CARBON MODULE ASSEMBLY
3	1	M07-03	UPPER ANGLED HOUSING ASSEMBLY
4	1	M07-04	LOWER ANGLED HOUSING ASSEMBLY
5	1	M07-05	3.25" PLEAT FLANGE ASSEMBLY
6	1	M07-06	MOUNTING ADAPTER ASSEMBLY
7	1	M07-07	MOTOR/BLOWER PLATE
8	2	M07-08	BLOWER BRACKET
9	1	M07-09	BLOCK OFF PLATE
10	1	DAYTON_5NRC6	10" BLOWER ASSEMBLY (DIRECT DRIVE)
11	4	MAF-EYE-352446	5/16-18 X 1-1/8" LG LIFTING EYE BOLT
12	1	MAE-BOX-2DDD1	STANDARD 2 GANG ELECTRICAL BOX
13	1	MAE-COV-4A240	STANDARD WALL PLATE

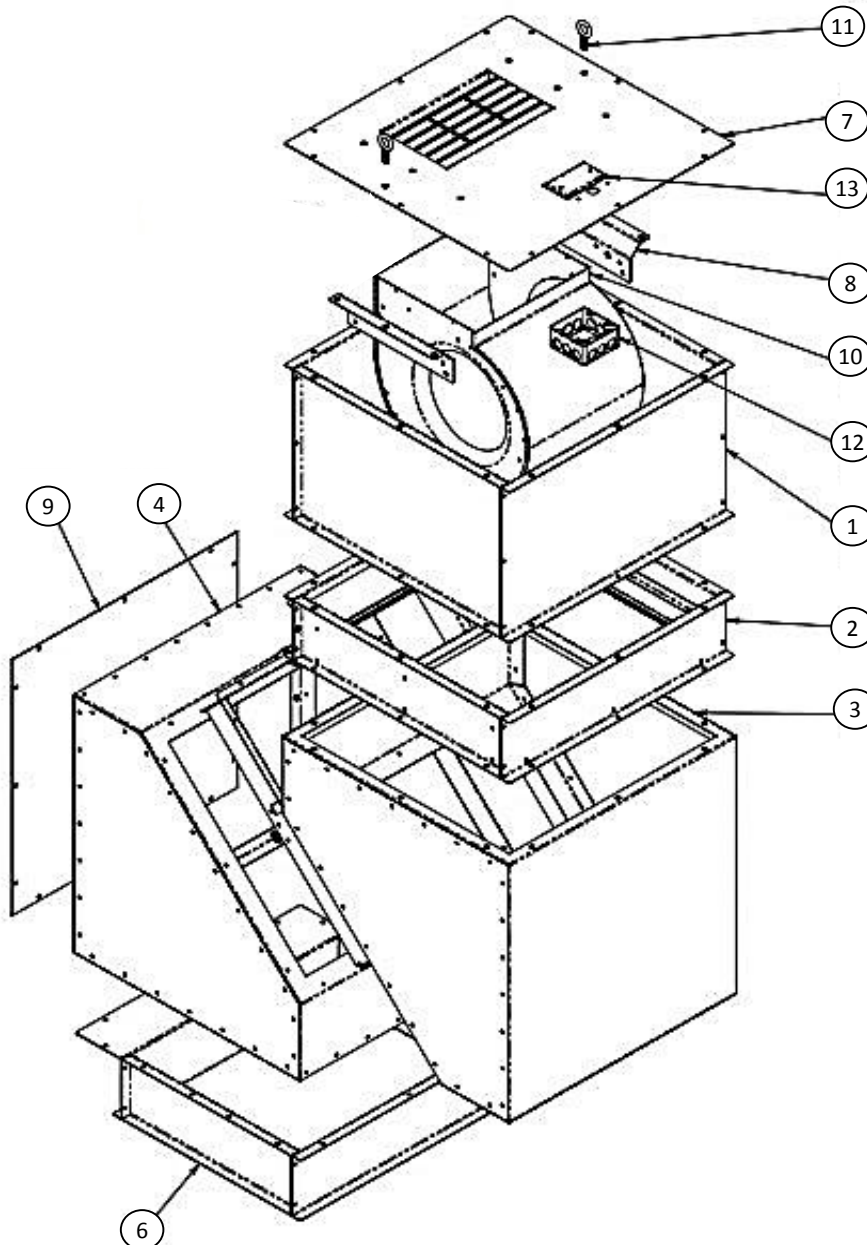

**Coolant Mist Collector.com**

By  
**Module-Air.com**

<b>Part #</b>	<b>Description</b>	<b>Size (nominal)</b>	<b>Model for use in</b>
ACF24242	Activated Charcoal Filter	24x24x2	AF07M1220
FBF95242415G	95% Fiberglass Bag Filter	24x24x12	AF07M1220
CCF24246	Coalescing Filter	24x24x6	AF07M1220
ACF16162	Activated Charcoal Filter	16x16x2	AF03M1220
FBF95161612	95% Fiberglass Bag Filter	16x16x12	AF03M1220
CCF16166	Coalescing Filter	16x16x6	AF03M1220

TO REORDER FILTERS PLEASE CONTACT TANIS TECHNOLOGIES LLC

[INFO@TANISTECHNOLOGIES.COM](mailto:INFO@TANISTECHNOLOGIES.COM)

[WWW.MODULE-AIR.COM](http://WWW.MODULE-AIR.COM)

PHONE: 616-990-8005

FAX: 616-796-1213



## Limited One (1) Year Parts Warranty

MODULE-AIR warrants all MODULE-AIR filtration products to be free from defects in materials or workmanship. This warranty is valid for the original purchaser and for a period of one (1) year from the date of shipment or installation sign off. The liability of MODULE-AIR is limited expressly to the replacement or rebuilding of any article, or part thereof, proven defective, when returned by authorized approval to MODULE-AIR, transportation prepaid, within a reasonable time after the termination of the 365-day warranty. Customer must be able to provide proof of purchase in order to submit a claim.

NOTE: In order to maintain the one year warranty on MODULE-AIR products replacement filters must be purchased from MODULE-AIR for that first year. Proof of filter orders must be kept on file and be readily available upon request by MODULE-AIR.

This warranty is void if the product is installed or assembled in any manner that contradicts the instructions specified by MODULE-AIR, or if the product is dismantled, modified, altered or damaged from improper maintenance, excessive temperature, excessively dirty filters, or other abuse. This warranty does include standard warranties from purchased parts such as motors, blowers, ect. Any part which is determined to be defective in material or workmanship can be shipped, prepaid, to MODULE-AIR or authorized service facility in which case a determination will be made whether to repair or replace the component.

MODULE-AIR is not responsible for shipping costs related to sending replacement parts to customer or customer returning parts to MODULE-AIR for inspection. All freight costs incurred by warranty claims are the responsibility of the customer.

MODULE-AIR is not responsible for any damages to buildings or equipment nor is liable for any injuries caused by filter fires. Customers are responsible for choosing necessary spark arrestor accessories and equipment.

No representative, agent or employee of MODULE-AIR has any authority to modify the terms of this warranty. MODULE-AIR will not be responsible for any consequential or resulting damage which may be claimed to have occurred though the sale or use of such products or parts thereof, which might be defective.

There are no warranties which extend beyond the description contained under this heading, express or implied, including warranties of fitness for a particular purpose.

Any damages incurred while parts are in transit from customer to MODULE-AIR or authorized service facilities are the responsibility of the sender. MODULE-AIR and distributors reserve the right to freeze the warranty claim process if parts are damaged in shipping until customer can be contacted and informed.

Module-Air, L.L.C.  
645 Commerce Court, Suite 10 Holland, MI 49424  
Phone: 616-990-8005 Fax: 616-796-1213